

ALTERNATE INSTALLATION  
SINGLE MAILBOX ONLY

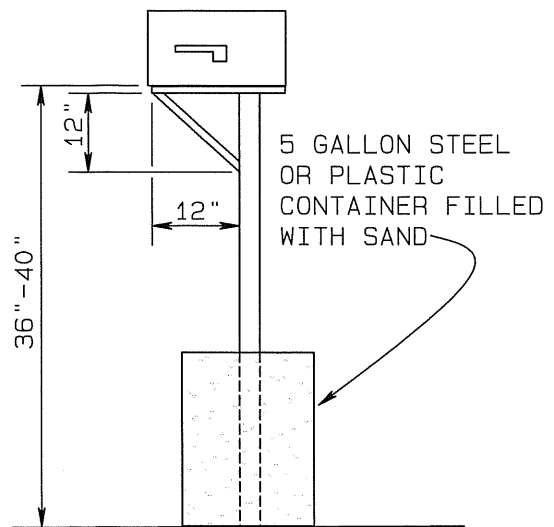
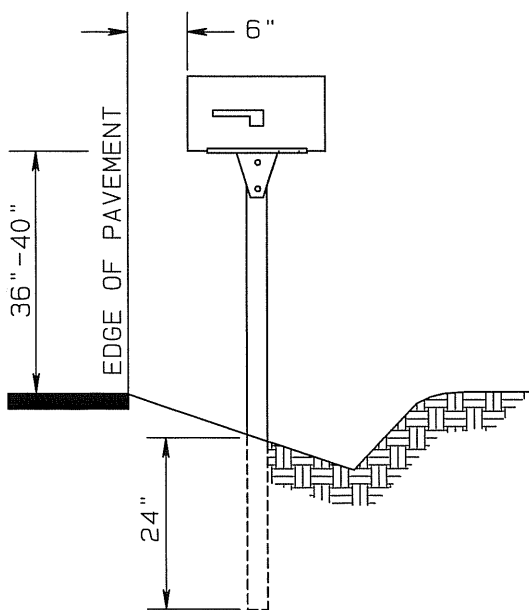

TEMPORARY INSTALLATION

NOTES

1. POSTS SHALL BE 4X4 PRESSURE TREATED CONFORMING TO SECTION 80-3 OF CALTRANS SPECIFICATIONS. SUPPORTS AND BRACE SHALL BE 2X4 REDWOOD S4S. NAILS SHALL BE 12d GALVANIZED NAILS.
2. THE DIMENSION FOR 'L' SHALL BE DETERMINED BY THE ENGINEER TO MEET FIELD CONDITIONS.

COUNTY OF SONOMA  
DEPARTMENT OF TRANSPORTATION  
AND PUBLIC WORKS

MAILBOX INSTALLATION  
WITH WOODEN POST

DATE: MAY 2004

REVISED: APR. 2005

APPROVED BY:

SCALE:  
NONE

DRAWING NO.

306