

PLACE THE ARTERIAL STREET NAME SIGN PANEL IN THE TOP POSITION

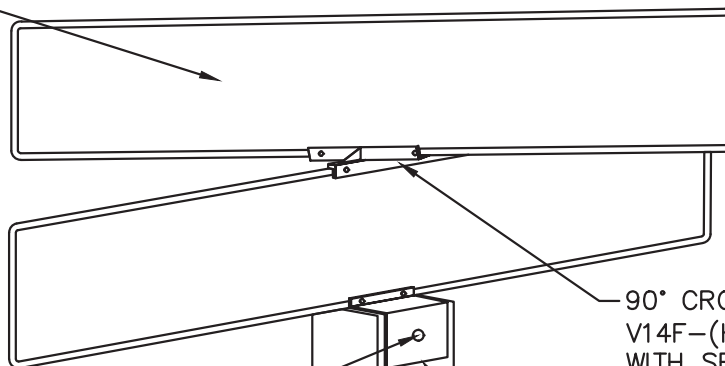

5/16" X 1-1/2" LAG SCREW (GALVANIZED)

SEE NOTE 6 AND DRAWING NO. 712

90° CROSSPIECE HAWKINS V14F-(HD)-SL-105(90) WITH SET SCREWS OR APPROVED EQUAL

CAP TO FIT S4S WOOD POST HAWKINS V14F-(HD)SL-4WPC WITH SET SCREWS OR APPROVED EQUAL.

NOTES:

1. THE BASE METAL OF ALL SIGNS SHALL BE NEW SHEET ALUMINUM OF ALLOYS 6061-T6 OR 5052-H38 CONFORMING TO THE REQUIREMENTS OF ASTM DESIGNATION B209, WITH A THICKNESS OF 0.125".
2. SIGNS SHALL BE DOUBLE FACED.
3. B-SERIES LETTERING MAY BE USED IF THE STREET NAME IS TOO LONG FOR MAXIMUM LENGTH OF SIGN.
4. LETTERING AND ABBREVIATIONS SHALL BE AS SHOWN ON THIS DRAWING AND IN CONFORMANCE WITH THE CURRENT EDITION OF THE CALIFORNIA MANUAL OF UNIFORM TRAFFIC CONTROL DEVICES.
5. CROSS PIECE AND POST CAP SLOT WIDTH SHALL BE OF SUFFICIENT WIDTH TO FIT THE SIGN PLATE.
6. WOOD POSTS SHALL BE 4"x4" S4S PRESSURE TREATED CONFORMING TO SECTION 56 OF CALTRANS SPECIFICATIONS, EXCEPT THAT REDWOOD SHALL NOT BE ALLOWED.

COUNTY OF SONOMA DEPARTMENT OF TRANSPORTATION AND PUBLIC WORKS		
STREET NAME SIGN WOODEN POST MOUNTING		
DATE: MAY 2004	REVISED: MAY 2007	
APPROVED BY: JH	SCALE: NONE	DRAWING NO. 702