

**AGENDA
BOARD OF SUPERVISORS
SONOMA COUNTY
575 ADMINISTRATION DRIVE, ROOM 102A
SANTA ROSA, CA 95403**

TUESDAY

NOVEMBER 13, 2018

8:30 A.M.

(The regular afternoon session commences at 1:30 p.m.)

Susan Gorin	First District	Sheryl Bratton	County Administrator
David Rabbitt	Second District	Bruce Goldstein	County Counsel
Shirlee Zane	Third District		
James Gore	Fourth District		
Lynda Hopkins	Fifth District		

This is a simultaneous meeting of the Board of Supervisors of Sonoma County, the Board of Directors of the Sonoma County Water Agency, the Board of Commissioners of the Community Development Commission, the Board of Directors of the Sonoma County Agricultural Preservation and Open Space District, the Sonoma County Public Finance Authority, and as the governing board of all special districts having business on the agenda to be heard this date. Each of the foregoing entities is a separate and distinct legal entity.

The Board welcomes you to attend its meetings which are regularly scheduled each Tuesday at 8:30 a.m. Your interest is encouraged and appreciated.

AGENDAS AND MATERIALS: Agendas and most supporting materials are available on the Board's website at <http://www.sonoma-county.org/board/>. Due to legal, copyright, privacy or policy considerations, not all materials are posted online. Materials that are not posted are available for public inspection between 8:00 a.m. and 5:00 p.m., Monday through Friday, at 575 Administration Drive, Room 100A, Santa Rosa, CA.

SUPPLEMENTAL MATERIALS: Materials related to an item on this agenda submitted to the Board after distribution of the agenda packet are available for public inspection in the Board of Supervisors office at 575 Administration Drive, Room 100A, Santa Rosa, CA, during normal business hours.

DISABLED ACCOMMODATION: If you have a disability which requires an accommodation, an alternative format, or requires another person to assist you while attending this meeting, please contact the Clerk of the Board at (707) 565-2241 or bos@sonoma-county.org as soon as possible to ensure arrangements for accommodation.

Public Transit Access to the County Administration Center:

Sonoma County Transit: Rt. 20, 30, 44, 48, 60, 62; Santa Rosa CityBus: Rt. 14; Golden Gate Transit: Rt. 80
For transit information call (707) 576-RIDE or 1-800-345-RIDE or visit or <http://www.sctransit.com/>

APPROVAL OF THE CONSENT CALENDAR

The Consent Calendar includes routine financial and administrative actions that are usually approved by a single majority vote. There will be no discussion on these items prior to voting on the motion unless Board Members request specific items be discussed and/or removed from the Consent Calendar. There will an opportunity for the public to comment on the consent calendar prior to it being voted upon.

PUBLIC COMMENT

Any member of the public may address the Board on a matter listed on the agenda. Commenters are requested to fill out a Speaker Card and to come forward to the podium when recognized by the Board Chair. Please state your name and limit your comments to the agenda item under discussion. Available time for comments is determined by the Board Chair based on agenda scheduling demands and total number of speakers.

LANGUAGE INTERPRETERS: Language services are available at all regular and special Board and Committee meetings if made at least 48 hours in advance of the meeting to help ensure availability. For more information or to request services: Contact (707) 565-2241.

AVISO EN ESPAÑOL: Servicios de traducción están disponibles en todas las reuniones regulares y especiales, de la Mesa de Supervisores, si se solicita por lo menos 48 horas antes de la reunión. Para más información o para solicitar servicios, de traducción llame al (707) 565-2241

**8:30 A.M. CALL TO ORDER
PLEDGE OF ALLEGIANCE**

I. APPROVAL OF THE AGENDA

(Items may be added or withdrawn from the agenda consistent with State law)

II. CONSENT CALENDAR

BOARD OF SUPERVISORS/HUMAN RESOURCES

AND

**SONOMA COUNTY WATER AGENCY, AND BOARD OF DIRECTORS
OF THE SONOMA COUNTY AGRICULTURAL PRESERVATION AND**

OPEN SPACE DISTRICT

(Directors: Gorin, Rabbitt, Zane, Gore, Hopkins)

AND

COMMUNITY DEVELOPMENT COMMISSION

1. Miscellaneous Classification, Compensation, and Allocation Changes:

Adopt Concurrent Resolutions reflecting the recommendations of completed classification studies and other position allocation changes:

- A) Adopt a Concurrent Resolution amending the Salary Resolution No. 95-0926, Appendix A – Salary Tables, to establish two new classifications and salaries; and to adjust the salaries of two existing classifications, effective November 13, 2018.
- B) Adopt a Concurrent Resolution approving the reclassification of two Sonoma County Water Agency positions, with the retention of affected incumbents; and amending the Department Allocation Tables of the Auditor-Controller-Treasurer-Tax Collector’s Office, Department of Health Services, District Attorney’s Office, General Services Department, Information Services Department, and the Sonoma County Water Agency, effective November 13, 2018.

AGRICULTURAL PRESERVATION AND OPEN SPACE DISTRICT

(Directors: Gorin, Rabbitt, Zane, Gore, Hopkins)

AND

REGIONAL PARKS

2. Wilroth Conservation Easement: Amendment to Conservation Easement:

- A) Board of Directors: Adopt a Resolution making certain findings and (1) authorizing an amendment to the Wilroth Conservation Easement permitting the installation of an early warning fire camera on the property; and (2) authorizing the President of the Board to execute the easement amendment and all other documents to be recorded in connection with the easement amendment; and (3) delegating authority to the District’s General Manager to take all necessary steps to effectuate the amendment of the easement.
- B) Board of Supervisors: Consent to and authorize the Chair to execute the amendment to the Wilroth Conservation Easement as owner of a portion of the property subject to the Wilroth Conservation Easement that will not be impacted by the amendment.

(Unanimous Vote Required)(First District)

AGRICULTURAL PRESERVATION AND OPEN SPACE DISTRICT

(Directors: Gorin, Rabbitt, Zane, Gore, Hopkins)

3. Graton Green Matching Grant Project:
Adopt a resolution of the Board of Directors of the Sonoma County Agricultural Preservation and Open Space District making certain findings, approving a grant of up to \$103,124 for the Graton Green Matching Grant Project, authorizing the acquisition of a conservation easement and recreation covenant, and authorizing and directing the General Manager to take all other actions necessary to establish a conservation easement, recreation covenant and grant agreement. (Fifth District)
4. Mattos Dairy SALCP Grant Agreement:
Approve resolution of the Directors of the Sonoma County Agricultural Preservation and Open Space District (a) ratifying the submission of an application to the State of California Department of Conservation for a \$750,000 grant under the Sustainable Agricultural Lands Conservation Program towards acquisition of a conservation easement, (b) authorizing the Board President to sign a letter certifying that there is no known conflict of interest, or the appearance of a conflict of interest, for the Board or any of its members with respect to the proposed funding, and (c) authorizing the General Manager to sign the Sustainable Agricultural Lands Conservation Program Grant Agreement for the Mattos Dairy conservation easement project. (Second District)

COMMUNITY DEVELOPMENT COMMISSION

(Commissioners: Gorin, Rabbitt, Zane, Gore, Hopkins)

AND

BOARD OF SUPERVISORS

5. Santa Rosa Armory Temporary Overnight Winter Shelter Program:
 - A) Authorize the Executive Director of the Community Development Commission to execute on behalf of the County of Sonoma a License Agreement with the California Military Department for the use of the Santa Rosa National Guard Armory as a temporary overnight homeless shelter.
 - B) Authorize the Executive Director of the Community Development Commission to execute an agreement with St. Vincent De Paul – Sonoma to operate a temporary overnight homeless shelter.

SONOMA COUNTY WATER AGENCY/OCCIDENTAL SANITATION DISTRICT/RUSSIAN RIVER SANITATION DISTRICT/ SOUTH PARK COUNTY SANITATION DISTRICT

(Directors: Gorin, Rabbitt, Zane, Gore, Hopkins)

AND

SONOMA VALLEY SANITATION DISTRICT

(Directors: Gorin, Gore, Agrimonti)

6. As-Needed Supervisory Control and Data Acquisition System Support and Related Services:
Authorize Sonoma County Water Agency's General Manager to execute an agreement with CH2M HILL Engineers, Inc. for as-needed supervisory control and data acquisition system support and related services through July 30, 2021, in an amount not to exceed \$1,000,000. These consultant services will help Sonoma Water maintain and improve its industrial systems infrastructure, which is needed to efficiently and safely conduct daily water and wastewater operations.

BOARD OF SUPERVISORS
AND
SONOMA COUNTY WATER AGENCY
(Directors: Gorin, Rabbitt, Zane, Gore, Hopkins)

7. Resolution in Support of a Two-Basin Solution for the Future of the Potter Valley Project:
Adopt a Concurrent Resolution Supporting a Two-Basin Solution for the Future of the Potter Valley Project

SONOMA COUNTY WATER AGENCY
(Directors: Gorin, Rabbitt, Zane, Gore, Hopkins)

8. Advanced Quantitative Precipitation Information System – Consulting Agreements In support of the Bay Area Advanced Quantitative Precipitation Information System Project, which provides more precise rainfall forecasting to inform flood control, emergency response efforts, and media reporting:
- A) Authorize Sonoma County Water Agency’s General Manager to execute an agreement with Jennifer Krebs dba Jennifer Krebs Environmental Planning for project coordination services through December 31, 2021, in the not-to-exceed amount of \$250,000.
 - B) Authorize Sonoma County Water Agency's General Manager to execute an agreement with Bay Planning Coalition for stakeholder outreach coordination through December 31, 2021, in the not-to-exceed amount of \$300,000.
 - C) Adopt a resolution authorizing adjustments to the Board Adopted Budget for Fiscal Year 2018-2019 in the amount of \$160,418 for the Bay Area Advanced Quantitative Precipitation Information System Project.
(4/5th Vote Required)
9. Budget Resolution for the Airport-Larkfield-Wikiup Sanitation Zone and the Sonoma County Water Agency General Fund:
Adopt a Resolution ratifying and approving adjustments to the Board Adopted Budget for Fiscal Year 2018-2019 to transfer \$110,000 from the Sonoma County Water Agency General Fund to the Airport-Larkfield-Wikiup Sanitation Zone Rate Stabilization Fund, and \$211,500 from the Rate Stabilization Fund to the Airport-Larkfield-Wikiup Sanitation Zone Operations Fund to Comply with Airport-Larkfield-Wikiup Sanitation Zone Debt Financing Covenants. (4/5th Vote Required)(Fourth District)

AUDITOR- CONTROLLER-TREASURER-TAX COLLECTOR

10. Department Allocation Amendment:
Adopt a Personnel Resolution effective November 13, 2018, adding one (1 FTE) Department Information Systems Coordinator and deleting one (1 FTE) Department Analyst from the Auditor-Controller-Treasurer-Tax Collector's position allocation list.
11. Northern Sonoma County Air Pollution Control District Fiscal Audit Frequency –Biennial:
Adopt Resolution in support of the Northern Sonoma County Air Pollution Control District performing biennial fiscal audits. (Unanimous Vote Required)

12. Authorizing Examination of Sales and Transaction Use Tax Records; Civitas Advisors, LLC: Adopt a Resolution Authorizing the Examination of Sales and Transaction and Use Tax Records Signature of Sales, Transactions, and Use Tax Information Nondisclosure Agreement.

BOARD OF SUPERVISORS

13. Board of Supervisors Calendar of Meetings for 2019:
Approve the County of Sonoma Board of Supervisors calendar of meetings for the year 2019.
14. Sonoma County Williams Act Settlement Annual Report of Findings:
Accept Sonoma County Superintendent of Schools Report on Williams Lawsuit Settlement findings for Fiscal Year 2017-2018. (Informational Only)
15. Fifth District Municipal Advisory Councils Update:
 - A) Approve updates to the Lower Russian River and Sonoma County Coast Municipal Advisory Council Bylaws.
 - B) Approve updates to the Sonoma County Coast Municipal Advisory Council map. (Fifth District)
16. Board of Supervisors Meeting Minutes:
Approve the Minutes of the meetings September 11, 18, 25, October, 2, 9, 16, 23, and 30, 2018 and Approve the Minutes of the meeting October 23, 2018 for the Sonoma Valley County Sanitation District.
17. Disbursement of Fiscal Year 2018-2019 Second District Community Investment Fund Grant Awards:
Approve Community Investment Fund grant awards and Authorize the County Administrator, or designee, to execute an agreement with the following non-profit entities for advertising and economic development efforts for FY 2018-2019: Children’s Museum of Sonoma County, \$2,500; Operation Access, \$500; Petaluma Arts Council, \$2,500; Petaluma Museum Association, \$2,000; Sonoma County Farm Trails, \$5,000; and Sonoma County Pride for the LGBTQI Pride Summer Celebration 2019, \$1,000. (Second District)
18. Disbursement of Fiscal Year 2018-2019 Third District Community Investment Fund Grant Awards:
Approve Community Investment Fund grant awards and Authorize the County Administrator, or designee, to execute an agreement with the following non-profit entities for advertising and economic development efforts for FY 2018-2019: Sonoma County Pride - Sonoma County LGBTQI Pride Summer Celebration, \$500; Lo Cien Sonoma County - Voter Education program, State of Latino Community forum, monthly forums and events, \$2,000; Children's Museum of Sonoma County – Children's Museum of Sonoma County promotion and advertising, \$2,000; Buck Institute for Research on Aging - North Bay Science Discovery Day 2018, \$300; Operation Access - Healthy Spirits 25th Anniversary Celebration, \$500; 6th Street Playhouse - 2018-19; Season of 6th Street Playhouse, \$2,000; Santa Rosa Symphony - 2018–2019 season of Free Concerts for Youth, \$3,000; Sonoma County Bicycle Coalition – Bicycle safety programs, \$2,500; Latino Health Forum – Latino Health Forum, \$750. (Third District)

19. Disbursement of Fiscal Year 2018-2019 Fourth District Community Investment Fund Grant Awards:
Approve Community Investment Fund grant awards and Authorize the County Administrator, or designee, to execute an agreement with the following non-profit entities for advertising and promotions activities for FY 2018-2019: California Indian Museum and Cultural Center – ACORN, \$1,000; Children’s Museum of Sonoma County – Campaign of Awareness, \$550; Cloverdale Arts Alliance – Friday Night Live on the Plaza, \$8,000; Los Cien, Sonoma County Inc. – State of the Latino Community Forum, \$700; Slow Food – Apples at the Airport, \$1,000; Sonoma County Farm Trails – tours and events, \$750; and Town of Windsor – Summer Nights on the Green, \$1,000. (Fourth District)

**COUNTY ADMINISTRATOR/COUNTY COUNSEL/
HEALTH SERVICES**

20. Solid Waste Independent Hearing Panel compensation and proposed dissolution; adoption of procedures governing appointment of Hearing Officer:
A) Adopt a procedure to appoint a Solid Waste Independent Hearing Officer to hear local appeals for solid waste permitting and enforcement issues;
B) Adopt a resolution setting per diem compensation for Solid Waste Independent Hearing Panel members service, and approving retroactive reimbursement to 2016-17;
C) Disband the Solid Waste Independent Hearing Panel;
D) Adopt a resolution rescinding Resolution No. 92-0156, which established the Panel in 1992; and
E) authorize staff to recruit hearing officers.
(4/5th Vote Required)

COUNTY ADMINISTRATOR/ FIRE AND EMERGENCY SERVICES

21. Extend Proclamation of Local Emergency Due to the Sonoma Complex Fires:
Adopt a Resolution Extending the Proclamation of Local Emergency Issued on October 9, 2017, for another 30 Days Due to Damage Arising from the Complex Fires. (4/5th Vote Required)

ECONOMIC DEVELOPMENT BOARD

22. Funding for Economic Development Board Tourism Reports and Research:
Approve and authorize the Chair of the Board to execute a Memorandum of Understanding (MOU) with the Sonoma County Tourism Bureau (SCTB), to provide \$51,000 in revenues for the Economic Development Board in exchange of various research and report services to the SCTB from July 1, 2018 through June 30, 2019.
23. Sonoma County Economic Development Board Foundation Annual Report for FY17-18:
Receive the Sonoma County Economic Development Board Foundation’s Annual Report for Fiscal Year ending June 30, 2018.

FIRE AND EMERGENCY SERVICES

24. Concurrent Resolution Supporting the Application to the Local Agency Formation Commission for the Reorganization of the Windsor Fire Protection District:
Approve a Concurrent Resolution of the Board of Directors of the Windsor Fire Protection District, Rincon Valley Fire Protection District, Bennett Valley Fire Protection District and Sonoma County Board of Supervisors supporting the Reorganization of the Windsor Fire Protection District. (First, Third, Fourth and Fifth District)

GENERAL SERVICES/HEALTH SERVICES

25. Lease extensions (2) for office space for Department of Health Services at 16390 Main Street, Guerneville:
Consider multiple actions ensuring continued public access to health services in west county:
- A) Authorize the Clerk of the Board to publish a notice, declaring the Board's intent to enter into lease amendments (2) with Kirk Veale d/b/a Veale Investment Properties to:
 - i. Extend the term of a lease for 1,918 sq. ft. of office space (Suites B and G) located at 16390 Main Street, Guerneville, through October 31, 2023 and to specify the monthly rent payments;
 - ii. Extend the term of a lease for 583 sf. ft. of office space (Suites F, H, I and J) at 16390 Main Street, Guerneville through November 30, 2023, and to specify the monthly rent payments; and
 - B) Authorize the General Services Director, in consultation with and using forms approved by the County Counsel, to execute future lease amendments, extension options, and associated documents required for County use of the premises under the leases, and which are consistent with the material terms of the leases and which, other than the extension options contained therein, do not extend the term of the leases.

GENERAL SERVICES

26. 2018 Guerneville Winter Shelter License Agreement:
- A) Authorize the Director of General Services to execute a revocable license agreement with West County Community Services for the 2018 Winter Shelter located at the Guerneville Veterans Memorial Veterans Building commencing on December 1, 2018 and terminating on March 31, 2019, to provide housing to the homeless through the winter months.
 - B) Make findings in accordance with Section 26227 of the Government Code that the services provided by the licensee will serve public purposes and that the property subject to the license will not be needed for County purposes during the time of the licensee's possession. (Fifth District)
27. Cloverdale Veterans Memorial Hall Solar Pool Heater Capital Project:
- A) Approve the addition of the Cloverdale Veterans Building Solar Pool Heater Capital Project in the FY 2018-19 Capital Projects Budget, at an estimated cost of \$94,000.
 - B) Authorize the Director of General Services to enter into funding agreement with the City of Cloverdale and the Cloverdale Unified School District to jointly fund the procurement and installation of a solar thermal pool heater for the swimming pool at the Cloverdale Veterans Building, with a County fund contribution not to exceed \$50,000.
 - C) Adopt a resolution authorizing adjustments to the 2018-19 Final Budget in the amount of \$44,000.
(4/5th Vote Required)(Fourth District)

HEALTH SERVICES

28. Dissolution of the Sonoma County Commission on AIDS:
Adopt a resolution dissolving the Sonoma County Commission on AIDS effective November 27, 2018; as supported by the Commission on AIDS to eliminate duplication with other organizations such as the HIV Service Providers Coalition.
29. First 5 Sonoma County Commission Quality Rating and Improvement System Agreements:
- A) Authorize the Director of Health Services to execute a memorandum of understanding with the Sonoma County Office of Education for the County of Sonoma to receive revenue, which will support First 5 Sonoma County efforts to improve the quality of education provided in early education sites in Sonoma County, in the amount of \$364,980 through September 30, 2019.
 - B) Authorize the Director of Health Services to execute an agreement with Community Child Care Council of Sonoma County for quality rating and improvement system services, which serve to improve the quality of education provided in early education sites in Sonoma County, for the period July 1, 2018 to September 30, 2019 in an amount not-to-exceed \$303,763.
 - C) Adopt a resolution adjusting the fiscal year 2018-2019 final budget by increasing revenues by 323,777 and expenditures in the Department of Health Services by \$287,560 to reflect receipt of Sonoma County Office of Education grant revenue and associated expenditures. (4/5 vote required)

HUMAN RESOURCES/COUNTY COUNSEL

30. Investigation Service Agreement Third Amendment:
Authorize the Director of Human Resources and County Counsel to execute a third amendment to the existing master agreement with Kronick, Moskovitz, Tiedemann & Girard for workplace investigations for an additional two year term (October 1, 2018 to September 30, 2020) with an amount not to exceed \$525,000.

INFORMATION SYSTEMS/HEALTH SERVICES

31. Approval of Department of Health Services, Public Health - Environmental Health Records Retention Schedule Version Number 3 and Department of Health Services, Public Health - Animal Services Records Retention Schedule Version Number 3:
Adopt a Resolution approving the revised records retention schedules for the Department of Health Services, Public Health - Environmental Health and Department of Health Services, Public Health - Animal Services and authorizing the destruction of records in accordance with the approved retention schedules. (4/5th Vote Required)

PERMIT AND RESOURCE MANAGEMENT

32. Contract Extension for Capacity Threshold Study for Dry Creek Valley and Sonoma Valley:
- A) Authorize the Director of Permit Sonoma to execute an amendment to an agreement with Omni Means (now a GHD Company) for Phase IV of the Dry Creek Valley, Westside Road and Sonoma Valley Capacity Threshold Study increasing the contract amount by \$67,195 resulting in a new not-to-exceed amount of \$167,188.
 - B) Authorize the Director of Permit Sonoma to execute an Assignment, Novation and Consent Agreement by and among Omni Means Engineering Solutions, A California Corporation (“Assignor”), GHD, a California Corporation (“Assignee”), and the County of Sonoma, a political subdivision of the State of California (“County”) for the Dry Creek Valley, Westside Road and Sonoma Valley Capacity Threshold Study agreement.
 - C) Authorize the Director of Permit Sonoma to execute an Assignment, Novation and Consent Agreement by and among Omni Means Engineering Solutions, A California Corporation (“Assignor”), GHD, a California Corporation (“Assignee”), and the County of Sonoma, a political subdivision of the State of California (“County”) for the Traffic Study Peer Reviews agreement.

TRANSPORTATION AND PUBLIC WORKS

33. Charles M. Schulz – Sonoma County Airport Advertising Policy Resolution:
Adopt a resolution amending the Advertising Policy for the Charles M. Schulz – Sonoma County Airport.
34. Agreement for Environmental Assessment for Perimeter Fence Upgrade at Charles M. Schulz – Sonoma County Airport:
Authorize the Chair to execute an agreement with RS&H California, Inc., for preparation of a National Environmental Policy Act (NEPA) and California Environmental Quality Act (CEQA) environmental review in order to upgrade of the Sonoma County Airport wildlife perimeter fence. The proposed value of the agreement is \$155,607, with a three-year term ending November 13, 2021.
35. Landfill Gas Collection System, Operation, Monitoring, Maintenance and Reporting Services for the Healdsburg Closed Landfill:
Authorize the Chair to execute Amendment No. 1 to the Agreement for Landfill Gas Collection Services for the Healdsburg Closed Landfill By and Between the County of Sonoma and SCS Field Services to increase the Task 2 (non-routine services) dollar limit to a not-to-exceed total of \$175,000 per year with no change to term ending March 31, 2020. (Fourth District)

APPOINTMENTS/REAPPOINTMENTS

36. Approve the Reappointment of Dane H. Petersen, Edmund Stewart, and Tatsuo Okaya to the Geyserville Fire Protection District Board of Directors for a four year term beginning December 7, 2018 and expiring December 2, 2022. (Fourth District)
37. Approve the Re-appointment of Bruce Abelli-Amen, Jennifer Kuszmar, John J. Nagle, Walter J. Ryan, Jr. to the Sonoma Resource Conservation District Board for a four year term beginning December 7, 2018 and ending December 7, 2022 (Countywide).

38. Approve the Re-appointments of Melvin J. Sanchiotti and Torrey Olson to the Gold Ridge Resource Conservation District Board for a four year term beginning December 7, 2018 and ending December 7, 2022. (Countywide)
39. Approve the Re-appointment of Jason C. Weaver to the Russian River Fire Protection District Board for a two-year term beginning December 7, 2018 and ending December 7, 2020. (Fifth District)
40. Approve the Re-appointment of Socorro Shiels and Michele Rogers, PhD to the First 5 Sonoma County Commission for the three-year term of December 1, 2018 through November 30, 2021. (Health Services)
41. Approve the Appointment of Stella Gonzalez to the Child Care Planning Council of Sonoma County, as a Child Care Consumer Representative, for a two-year term beginning November 13, 2018, ending December 31, 2020. (Human Services and Sonoma County Office of Education)

PRESENTATIONS/GOLD RESOLUTIONS

PRESENTATIONS AT THE BOARD MEETING

(Gold resolutions are presented in the afternoon session at 1:30 P.M.)

42. Present a check along with Board Members of the “Sonoma County Children’s Charities-The Schulz” to be split evenly among the following non-profit partners who benefitted from the Schulz Celebrity Golf Tournament: PDI Surgery Center, Boys and Girls Club of Central Sonoma County, Santa Rosa Catholic Charities Family Support Center, Sonoma Academy Scholarship Fund, Charles M. Schulz Museum Children’s programs, and The First Tee North Coast. (Fourth District)
43. Adopt a resolution proclaiming December 1, 2018 as World AIDS Day in Sonoma County. (Health Services)

PRESENTATION ON A DIFFERENT DATE

44. Approve Gold Resolution declaring November 26 through November 30, 2018 as California Clerk of the Board of Supervisors Week. (Fourth District)
45. Adopt a resolution of the Board of Supervisors honoring and commending John C. Brown on the occasion of his retirement as Petaluma City Manager and his 35 years of public service. (Second District)

III. 8:45 A.M. - PUBLIC COMMENT ON MATTERS NOT LISTED ON THE AGENDA BUT WITHIN THE SUBJECT MATTER JURISDICTION OF THE BOARD AND ON BOARD MEMBER REPORTS

(Comments are restricted to matters within the Board’s jurisdiction. The Board will hear public comments at this time for up to thirty minutes. Each person is usually granted time to speak at the discretion of the Chair. Any additional public comments will be heard at the conclusion of the meeting. While members of the public are welcome to address the Board, under the Brown Act, Board members may not deliberate or take action on items not on the agenda.)

IV. REGULAR CALENDAR

SONOMA COUNTY WATER AGENCY

(Directors: Gorin, Rabbitt, Zane, Gore, Hopkins)

46. Sonoma County Water Agency Appointment of Retiree Extra-Help:
Pursuant to Government Code §7522.56 approve the appointment of Susan Keach as an Environmental Compliance Inspector Retiree Extra-Help, in order to fill a critically needed position within 180 days of her retirement, with an appointment date as early as November 13, 2018.

PERMIT AND RESOURCE MANAGEMENT

47. **9:00 A.M.** - Agricultural Preserve expansion and new Land Conservation Act contract; Steve Shaffer, Jack London Ranch, LLC; AGP17-0011:
Hold a public hearing and adopt a resolution to expand an existing Agricultural Preserve (2-457) by adding 151.24 acres and approve a new Prime Land Conservation (Williamson) Act contract and Land Conservation Plan on the same 151.24 acre parcel located at 2600 London Ranch Rd., Glen Ellen; APN 054-050-037; Permit Sonoma File No. AGP17-0011; Supervisorial District 1.
48. **9:05 A.M.** - Technical Corrections to Zoning for Properties Located at 15600 Highway 1 and 14500 Meyers Grade Rd, Jenner; File ZCE18-0011:
Hold a public hearing and adopt three Resolutions and three Ordinances finding the project exempt from the California Environmental Quality Act (CEQA) and approving technical zoning corrections to the Official Zoning Database and Coastal Zoning Database for two legal parcels of record.

AGRICULTURAL PRESERVATION AND OPEN SPACE DISTRICT

(Directors: Gorin, Rabbitt, Zane, Gore, Hopkins)

49. 2018 Matching Grant Program Funding Recommendations:
Accept Recommendations for Projects and Funding Amounts for the 2018 Matching Grant Program Cycle.

BOARD OF SUPERVISORS

50. Fee Waiver
Approve request for the Pacific Coast Air Museum for a fee waiver in the amount of \$650.00 for the Permit Sonoma event permit fee of \$650.00. The Pacific Coast Air Museum is a historical and cultural organization that has an annual Santa Claus Fly- In. The museum would like a fee waiver to bring the cost of this event within their budget. (Fourth District)

V. PUBLIC COMMENT ON CLOSED SESSION ITEMS

VI. CLOSED SESSION CALENDAR

51. The Board of Supervisors and the Board of Directors of the Sonoma County Water Agency will consider the following in closed session: Conference with Legal Counsel – Existing Litigation – Potter Valley Hydroelectric Project, FERC Project No. 77. (Government Code Section 54956.9(d)(1).)
52. The Board of Supervisors will consider the following in closed session Conference with Legal Counsel – Anticipated Litigation. Potential initiation of litigation pursuant to Government Code section 54956.9(d)(4). 1 case.
Code Enforcement matter regarding property at 30225 River Road, Cloverdale, District 4
Property Owners: Eugene F. Garibaldi Living Trust; Eugene F. Garibaldi, Jr., Eugene F. Garibaldi, Jacqueline Garibaldi, and Beth Garibaldi.
53. The Board of Supervisors, the Board of Directors of the Water Agency, the Board Commissioners of the Community Development Commission, and the Board of Directors of The Agricultural Preservation and Open Space District will consider the following in closed session: Conference with Labor Negotiators: Christina Cramer/Carol Allen, County of Sonoma, and Rick Bolanos/Heather Coffman, Liebert Cassidy & Whitmore. Employee Organizations: All. Unrepresented employees: All, including retired employees. (Government Code section 54957.6).

VII. REGULAR AFTERNOON CALENDAR

54. **RECONVENE FROM CLOSED SESSION**
55. **REPORT ON CLOSED SESSION**

VIII. 1:30 P.M. - PRESENTATIONS/GOLD RESOLUTIONS

COUNTY ADMINISTRATOR

56. County of Sonoma Five Year Budget Improvement Plan 2019-2023:
Receive and accept the County of Sonoma Five Year Budget Improvement Plan 2019-2023.
57. Transient Occupancy Tax Program Options:
A) Accept an update on options for the Transient Occupancy Tax program.
B) Provide direction to staff.

IX. BOARD MEMBER REPORTS ON ASSIGNED BOARDS, COUNCILS, COMMISSIONS OR OTHER ATTENDED MEETINGS

58. Permit and Resource Management Department: Review and possible action on the following:
Acts and Determinations of Planning Commission/Board of Zoning Adjustments
Acts and Determinations of Project Review and Advisory Committee
Acts and Determinations of Design Review Committee
Acts and Determinations of Landmarks Commission
Administrative Determinations of the Director of Permit and Resource Management
(All materials related to these actions and determinations can be reviewed at:
<http://www.sonoma-county.org/prmd/b-c/index.htm>)

59. **ADJOURNMENT**

NOTE: The next board meeting will be a Special Closed Session held on November 20, 2018.

The next Regular meeting will be held on December 4, 2018, at 8:30 a.m.

Upcoming Hearings (All dates are tentative until each agenda is finalized)

December 11, 2018 – PRMD - PE14-0008 Ramey Winery Appeal



County of Sonoma Agenda Item Summary Report

Agenda Item Number: 1
(This Section for use by Clerk of the Board Only.)

Clerk of the Board
575 Administration Drive
Santa Rosa, CA 95403

To: Board of Supervisors of the County of Sonoma, Board of Directors of the Sonoma County Water Agency, Board of Commissioners of the Community Development Commission, and Board of Directors of the Sonoma County Agricultural Preservation and Open Space District

Board Agenda Date: November 13, 2018

Vote Requirement: Majority

Department or Agency Name(s): Human Resources Department

Staff Name and Phone Number:

Jennifer Lelouarn, (707) 565-3565

Supervisorial District(s):

All

Title: Miscellaneous Classification, Compensation, and Allocation Changes

Recommended Actions:

Adopt Concurrent Resolutions reflecting the recommendations of completed classification studies and other position allocation changes:

1. Adopt a Concurrent Resolution amending the Salary Resolution No. 95-0926, Appendix A – Salary Tables, to establish two new classifications and salaries; and to adjust the salaries of two existing classifications, effective November 13, 2018.
2. Adopt a Concurrent Resolution approving the reclassification of two Sonoma County Water Agency positions, with the retention of affected incumbents; and amending the Department Allocation Tables of the Auditor-Controller-Treasurer-Tax Collector's Office, Department of Health Services, District Attorney's Office, General Services Department, Information Services Department, and the Sonoma County Water Agency, effective November 13, 2018.

Executive Summary:

The County's Human Resources Department is responsible for managing the County-wide classification and compensation structure. Components of this responsibility include ensuring employees are appropriately classified, administering the County's Compensation Plan, and assisting departments with organizational changes when they involve classification reviews. Regularly, the department conducts classification and compensation analyses, and develops reports and recommendations that are presented to incumbents, unions, departments, and in many situations the Civil Service Commission. Ensuring employees are appropriately classified and having a sound classification plan results in the County's ability to attract and retain a highly qualified, engaged workforce charged with providing the most efficient services possible for our community.

Several times throughout each year, Human Resources coordinates “Miscellaneous Classification and Allocation Change” Items for Board approval, which allow Human Resources and departments to implement the outcomes of classification, compensation, and allocation change recommendations.

In resolutions before your Board today Human Resources requests approval to implement the final recommendations resulting from classification studies in the Auditor-Controller-Treasurer-Tax Collector, District Attorney’s Office, General Services Department, and the Sonoma County Water Agency; to adjust the salary for two classifications, one in the Human Resources Department and one in the Waste Management Agency; and to change additional position allocations for the Department of Health Services and the Information Services Department.

Discussion:

Classification is a method for categorizing jobs based on duties, responsibilities, and a variety of other factors. A classification plan contains all of the classifications in the agency and forms the basis for setting job expectations, consistent and fair job entrance requirements, equitable compensation, and plays an important role in the budget. Human Resources is responsible for managing the County’s classification plan by evaluating job descriptions for vacant, filled, and new positions to ensure that they are assigned to the appropriate classifications. Positions are assigned, or allocated, to departments based on Human Resources’ determination of the appropriate classification.

The majority of the County’s positions/classifications are in the County’s Civil Service System. Therefore, most classification changes and new classifications are reviewed and approved by the Civil Service Commission, and the Board has final approval authority prior to the implementation of any classification changes. However, four agencies (i.e., Agricultural Preservation and Open Space District, Community Development Commission, Sonoma County Fair, and Sonoma County Water Agency) are not governed by the County’s Civil Service System, and the Board has sole authority for the related classification and compensation issues. As part of this effort, Human Resources is seeking approval for the following changes in classifications and allocations.

Auditor-Controller-Treasurer-Tax Collector’s Office:

The Auditor-Controller-Treasurer-Tax Collector’s Office (ACTTC) requested a review of one Accounting Manager, Auditor-Controller position assigned to the County’s Enterprise Financial System (EFS). Ralph Andersen & Associates, a professional consulting firm, was retained to conduct this study. As a result of the study, it was determined that the duties of this position have a strong information technology aspect that is beyond the scope of the current Accounting Manager, Auditor-Controller job classification. Further, it was determined that no existing classification would be appropriate for this single incumbent position, and that a new class, titled Enterprise Financial System Manager, should be established.

On October 18, 2018, the Civil Service Commission approved the creation of the new classification, the reclassification of the position, and the retention of the incumbent in accordance with Civil Service Rule 3.3B.

Bargaining Unit, Fair Labor Standards Act (FLSA), and Salary Determinations:

Pursuant to the County’s Employee Relations Policy, Human Resources determined the appropriate bargaining unit for the new Enterprise Financial System Manager classification is Bargaining Unit 0050-Administrative Management, and that this classification should be exempt, pursuant to the guidelines of the Fair Labor Standards Act.

Based on an evaluation of both market data and internal equity factors, Human Resources has determined that the salary for Enterprise Financial System Manager classification should be \$11,023/Monthly I-Step and the ongoing salary administration for the classification should be set at 13% above Department Information Systems Manager.

Department of Health Services:

The Department of Health Services' (DHS) Animal Services Division had one 1.0 FTE Animal Care Assistant allocation and one 0.50 FTE Animal Health Technician allocation, funded in the 2018-2019 adopted budget, inadvertently removed from the department's adopted allocation list. DHS is seeking the Board's approval to add these allocations back to its allocation list. Additionally, in order to align allocations with the department's needs, DHS requests approval to add a 1.0 FTE time-limited Behavioral Health Clinical Specialist allocation for its Mobile Support Team (MST) and to delete a vacant 1.0 FTE Public Health Nurse II allocation. The Mobile Support Team responds to requests from law enforcement when they encounter an individual who has mental health and/or substance use disorders issues. The clinical specialist will support the MST's expansion to East County to achieve an equitable distribution of critical crisis response throughout the county. The time-limited allocation will be in effect through June 30, 2021.

District Attorney's Office:

The District Attorney's Office's (DAO) requested that Human Resources review a Legal Processor II position assigned to its Discovery Desk. As a result of the class study, Human Resources found the Legal Processor II classification does not represent the independence, scope, and consequence of error required of the studied position. It was further determined that Senior Legal Processor is the appropriate classification for the studied position, as it provides for these factors and encompasses virtually all of the required duties.

On October 18, 2018, the Civil Service Commission approved the reclassification of the position and the retention of the incumbent in accordance with Civil Service Rule 3.3B.

General Services Department:

The General Services Department (GSO) asked Human Resources to study three Department Analyst positions assigned to the Department's Real Estate Unit. Through the study process it became clear that the positions' responsibilities exceed the scope of the Department Analyst class. In reviewing the other classifications in the County system, Human Resources found no existing classification that would be appropriate for these positions, and determined that a new Real Estate Project Specialist classification should be established.

On September 6, 2018, the Civil Service Commission approved the creation of the new classification, the reclassification of the studied positions, and the retention of the incumbents in accordance with Civil Service Rule 3.3B.

Bargaining Unit, Fair Labor Standards Act (FLSA), and Salary Determinations:

Pursuant to the County's Employee Relations Policy, Human Resources determined the appropriate bargaining unit for the new Real Estate Project Specialist classification is Bargaining Unit 0050-Administrative Management, and that this classification is exempt, pursuant to the guidelines of the Fair Labor Standards Act.

Based on an evaluation of both market data and internal equity factors, Human Resources has determined that the salary and ongoing salary administration for Real Estate Project Specialist classification should be set at \$7828/Monthly I-Step, and the ongoing salary administration for the classification should be set at 13% above Department Analyst.

Human Resources Department:

The Human Resources Department recently had an opportunity to re-evaluate a vacant Employee Relations Manager position's scope of managerial responsibilities, compared to the Department's newly created Deputy Human Resources Director classification. Human Resources determined that it would be appropriate to adjust the salary of the classification to reflect its more narrow scope of managerial responsibilities. Based on an evaluation of internal equity factors, Human Resources recommends that the Employee Relations Manager salary be revised from its current rate of \$13,149/Monthly I-Step to \$12,700/Monthly I-Step, which is a 4% reduction. Additionally, Human Resources recommends using the 4% differential to Deputy Human Resources Director for ongoing salary administration.

Information Services Department:

The Information Services Department's (ISD) Web Team workload has increased substantially, due to technology changes and the use of the web to facilitate communication and information to the public. In order to address this increased workload, ISD determined the need for an additional Programmer Analyst allocation to perform duties related to designing, troubleshooting, and deploying software applications designed for websites. The Information Services Department seeks approval to delete one 1.0 FTE vacant Mail, Materials & Records Handler II allocation and add one 1.0 FTE Programmer Analyst allocation.

Sonoma County Water Agency:

The Sonoma County Water Agency (SCWA) asked Human Resources to study one Automotive Mechanic and two Heavy Equipment Mechanic positions to determine whether they are appropriately classified. Koff & Associates, a professional consulting firm, was retained to conduct the study and determined that the Automotive Mechanic position would be more appropriately classified as an Automotive Technician, that one of the Heavy Equipment Technician positions would be more appropriately classified as a Lead Heavy Equipment Technician, and that the other is appropriately classified. Human Resources and SCWA management have reached agreement with Local 39 on these recommendations through the meet and confer process. The consultant's study report memoranda with these recommendations are attached (Attachment 4).

Waste Management Agency:

At October 17, 2018, Sonoma County Waste Management Agency Board meeting, the Board approved increasing the salary for the Waste Management Agency Executive Director classification in advance of conducting a recruitment to fill the position. Human Resources concurred that the salary be revised from its current rate of \$10,049/Monthly I-Step to \$10,561/Monthly I-Step, which is a 5% increase.

Consequences of Non-Approval: If these requests are not approved, the above positions will not be allocated to the appropriate classifications, classification changes approved by the County's Civil Service Commission will not be implemented, and salaries will not be appropriately adjusted.

Prior Board Actions:

Throughout the year, Human Resources submits several Miscellaneous Classification, Compensation, and Allocation Change Board Items that require Board approval in order to be fully adopted and implemented.

Strategic Plan Alignment Goal 4: Civic Services and Engagement

These changes support the alignment of the public services provided by the departments with community's needs by ensuring a professionally managed county organization that is accessible, transparent, fiscally responsible, and accountable to the public.

Fiscal Summary			
Expenditures	FY 18-19 Adopted	FY 19-20 Projected	FY 20-21 Projected
Budgeted Expenses	ACTTC: \$6,156 DAO: \$3,456 DHS: \$107,795 GSO: \$22,680 ISD: \$57,742 WTR: \$5,100	ACTTC: \$12,313 DAO: \$4,992 DHS: \$111,029 GSO: \$36,228 ISD: \$57,742 WTR: \$8,161	ACTTC: \$12,313 DAO: \$4,992 DHS: \$114,360 GSO: \$36,228 ISD: \$57,742 WTR: \$8,161
Additional Appropriation Requested			
Total Expenditures	\$202,929	\$230,465	\$233,796
Funding Sources			
General Fund/WA GF	DAO: \$3,456 GSO: \$22,680 WTR: \$5,100	DAO: \$4,992 GSO: \$36,228 WTR: \$8,161	DAO: \$4,992 GSO: \$36,228 WTR: \$8,161
State/Federal	DHS: \$26,949	DHS: \$27,757	DHS: \$28,590
Fees/Other	ACTTC: \$6,156 DHS: \$80,846 ISD: \$57,742	ACTTC: \$12,313 DHS: \$83,272 ISD: \$57,742	ACTTC: \$12,313 DHS: \$85,770 ISD: \$57,742
Use of Fund Balance			
Contingencies			
Total Sources	\$202,929	\$230,465	\$233,796
Narrative Explanation of Fiscal Impacts:			
<p>Auditor-Controller-Treasurer-Tax Collector: The increased cost of the annual salary and benefits for the reclassification of 1.0 Auditor Controller Accounting Manager position to 1.0 Enterprise Financial System Manager is estimate at \$6,156 for the remainder of FY18-19, and approximately \$12,313 for FY 19-20 and FY 20-21. This position is entirely funded through the EFS support organization and has sufficient salary and benefit appropriations through FY18-19. No additional appropriation is required.</p> <p>Department of Health Services: Health Services is deleting a Public Health Nurse II that is unfunded due to the elimination of the California Children’s Services program. In addition they are adding a time-limited Behavioral Health Clinical Specialist for the Mobile Support Team (MST). Funding for this position is provided by additional funding from the Board of Supervisors during the FY 18-19 Budget Hearings and a State grant for MST.</p> <p>District Attorney’s Office: The increase in projected cost of annual salary and benefits for the reclassification of 1.0 Legal Processor II position to 1.0 Senior Legal Processor is \$3,456 for the FY18-19, and \$4,992 for FY19-20 and FY20-21. The Department will fund the increase with the use of salary savings from unfilled positions, and no additional appropriation is needed.</p>			

General Services Department: The additional salary and benefit cost for replacing 3.0 FTE Department Analyst allocations with 3.0 FTE Real Estate Project Specialist allocations is projected to be \$22,680 in FY18-19, and \$36,228 for FY19-20 and FY20-21. The department has accounted for these costs via salary savings from unfilled positions and no additional appropriation is required.

Human Resources Department: There are no fiscal impacts associated with the slight decrease in salary for this position, which is currently vacant.

Information Services Department: The additional salary and benefit cost for replacing the Mail, Materials & Records Handler II allocation with a Programmer Analyst allocation on a budgetary basis is projected to be \$57,742 but the department will be filling this position as a Programmer Analyst Trainee and the actual cost is estimated to be \$11,948 in FY 18/19 and \$23,897 in FY 19/20. The department will cover total cost for the Programmer Analyst allocation through charges for services.

Sonoma County Water Agency: The increase in projected cost of ongoing annual salary and benefits for the reclassification of 1.0 Automotive Mechanic position to 1.0 Automotive Technician and 1.0 Heavy Equipment Mechanic position to 1.0 Lead Heavy Equipment Mechanic is \$8,161. Salary and benefits are budgeted in the General Fund which is funded through water sales revenue, taxes and grants. The General Fund is reimbursed by Water Agency enterprise funds through project costing. These increased labor costs will be funded by existing funds in the Water Agency's enterprise funds. The Water Agency's cost accounting system allocates labor costs to Water Agency projects specific to its enterprise funds.

Staffing Impacts

Position Title (Payroll Classification)	Monthly Salary Range (A – I Step)	Additions (Number)	Deletions (Number)
Accounting Manager – Auditor-Controller	\$8,221.51 - \$9,993.83		(1.0)
Enterprise Financial System Manager	\$9,069.00-\$11,023.00	1.0	
Animal Care Assistant	\$2,589.77-\$3,146.33	1.0	
Animal Health Technician	\$3,706.38-\$4,506.44	0.50	
Public Health Nurse II	\$6,788.36 - \$8,251.08		(1.0)
Behavioral Health Clinical Specialist	\$6,508.34 - \$7,910.18	1.0	
Legal Processor II	\$3,469.84 - \$4,219.46		(1.0)
Senior Legal Processor	\$3,814.21 - \$4,636.89	1.0	
Department Analyst	\$5,610.87 - \$6,819.66		(3.0)
Real Estate Project Specialist	\$6,442.00-\$7,828.00	3.0	
Mail, Materials & Records Handler II	\$3,450.71 - \$4,193.37		(1.0)
Programmer Analyst	\$6,090.91 - \$7,404.06	1.0	
Heavy Equipment Technician	\$5,123.88 - \$6,228.31		(1.0)
Lead Heavy Equipment Technician	\$5,614.35 - \$6,823.14	1.0	

Automotive Mechanic	\$4,678.63 - \$5,687.40		(1.0)
Automotive Technician	\$4,748.20 - \$5,772.63	1.0	

Narrative Explanation of Staffing Impacts (If Required):

Auditor-Controller-Treasurer-Tax Collector: The incumbent in the studied Accounting Manager – Auditor-Controller position will be retained in the new Enterprise Financial System Manager position in accordance with Civil Service Rule 3.3B.

The Department of Health Services: No incumbents are affected by the allocation changes, since the 1.0 FTE Public Health Nurse II allocation is vacant.

District Attorney’s Office: The incumbent in the studied Legal Processor II position will be retained in the new Senior Legal Processor position, in accordance with Civil Service Rule 3.3B.

General Services Department: Incumbents in three studied Department Analyst positions will be retained in the new Real Estate Project Specialist positions in accordance with Civil Service Rule 3.3B.

Information Services Department: No incumbent is affected by the allocation change, since the 1.0 FTE Mail, Materials & Records Handler II allocation is vacant.

Sonoma County Water Agency: The incumbent in the studied Automotive Mechanic position will be retained in the new Automotive Technician position, and the incumbent in the studied Heavy Equipment Technician position will be retained in the new Lead Heavy Equipment Mechanic position, pursuant to Water Agency Personnel Policy, Article V. Reclassification.

Attachments:

1. Resolution 1: Concurrent Resolution amending Salary Resolution No. 95-0926,
2. Resolution 1: Appendix A – Salary Tables.
3. Resolution 2: Concurrent Resolution approving the reclassification of two positions at the Sonoma County Water Agency, and amending the Allocation Tables of the Auditor-Controller-Treasurer-Tax Collector, the Department of Health Services, the District Attorney’s Office, the General Services Department, the Information Services Department, the Sonoma County Water Agency, and the Waste Management Agency.
4. Memoranda from Koff & Associates, a professional consulting firm, titled “Sonoma County Water Agency Classification Recommendation for Louie Lopez - Heavy Equipment Technician,” “Sonoma County Water Agency Classification Recommendation for Tony Bettiga, - Heavy Equipment Technician,” and “Sonoma County Water Agency Classification Recommendation for Gary Breazeale, Automotive Mechanic”.

Related Items “On File” with the Clerk of the Board:

1. Classification Study Report by Ralph Andersen & Associates, a professional consulting firm, of one Accounting Manager, Auditor-Controller position working as the Enterprise Financial System Manager of the Auditor-Controller-Treasurer-Tax Collector’s Office.
2. Classification Study Report by Human Resources on the Position Review of one Legal Processor II (Discovery Desk) at the District Attorney’s Office.
3. Classification Study Report by Human Resources on the Position Review of three Department Analyst positions assigned to the Real Estate Unit of the General Services Department.



County of Sonoma
State of California

Date: November 13, 2018

Item Number: _____
Resolution Number: _____

4/5 Vote Required

Concurrent Resolution Of The Board Of Supervisors Of The County Of Sonoma, State Of California, The Board Of Directors Of The Sonoma County Water Agency, The Board Of Commissioners Of The Community Development Commission, The Board Of Directors Of The Sonoma County Agricultural Preservation And Open Space District, And The Board Of Directors Of The Northern Sonoma County Air Pollution Control District Amending The County Of Sonoma Salary Resolution No. 95-0926, Appendix A - Salary Tables, Administrative Management – Bargaining Unit 0050 To Establish Two New Classifications And Salaries; And To Adjust The Salaries Of Two Existing Classifications, Effective November 13, 2018.

Whereas, a classification study conducted by Ralph Andersen & Associates, a professional consulting firm, of an Accounting Manager, Auditor-Controller at Auditor-Controller-Treasurer-Tax Collector's Office (ACTTC) determined the need for a new Enterprise Financial System Manager classification to appropriately perform the scope of duties and responsibilities of the studied position; and

Whereas, a classification study conducted by the Human Resources Department of three Department Analyst positions in the General Services Department's Real Estate Unit determined the need for a new Real Estate Project Specialist classification, as the positions' responsibilities exceed the scope of the Department Analyst classification; and

Whereas, pursuant to the Employee Relations Policy, Human Resources recommends both new classifications be represented by Administrative Management Bargaining Unit 0050; and

Whereas, Human Resources determined that the new management classifications are exempt in accordance with the Fair Labor Standards Act; and

Whereas, the Civil Service Commission approved establishing the two new classifications at their October 18, 2018, and September 6, 2018, meetings, respectively; and

Whereas, the Human Resources Department conducted an evaluation of the Employee Relations Manager position and determined that it would be appropriate to adjust the salary of the classification to reflect it's more narrow scope of managerial responsibilities; and

Whereas, the Sonoma County Waste Management Agency Board, at its October 17, 2018, meeting, approved increasing the salary of the Waste Management Agency Executive Director classification in advance of an upcoming recruitment;

Resolution #1

Date: November 13, 2018

Page 2

Now, Therefore, Be It Resolved that the County Of Sonoma Salary Resolution No. 95-0926, Appendix A - Salary Tables, Administrative Management – Bargaining Unit 0050, be amended to establish new classifications and salaries for Enterprise Financial System Manager and Real Estate Project Specialist; and to revise the salaries for the Employee Relations Manager and Waste Management Agency Executive Director classifications, as set forth in Attachment A, Effective November 13, 2018.

Supervisors:

Gorin:

Rabbitt:

Zane:

Hopkins:

Gore:

Ayes:

Noes:

Absent:

Abstain:

So Ordered.

**APPENDIX A
Salary Tables**

ADMINISTRATIVE MANAGEMENT – Bargaining Unit 0050

Job Code	Job Title	A Step Rate (March 14, 2017)	A Step Rate (September 25, 2018)
0409	Enterprise Financial System Manager	N/A	\$52.14
0762	Real Estate Project Specialist	N/A	\$37.04
0814	Employee Relations Manager	\$60.38	\$62.19 \$60.08

DEPARTMENT HEADS - Bargaining Unit 0052

Job Code	Job Title	A Step Rate (March 14, 2017)	A Step Rate (September 25, 2018)
0814	Waste Management Agency Executive Director	\$46.15	\$47.53 \$49.96



County of Sonoma
State of California

Date: November 13, 2018

Item Number: _____
Resolution Number: _____

4/5 Vote Required

Concurrent Resolution Of The Board Of Supervisors Of The County Of Sonoma, State Of California, The Board Of Directors Of The Sonoma County Water Agency, The Board Of Commissioners Of The Community Development Commission, The Board Of Directors Of The Sonoma County Agricultural Preservation And Open Space District, And The Board Of Directors Of The Northern Sonoma County Air Pollution Control District Approving The Reclassification Of Two Positions At The Sonoma County Water Agency, With The Promotion Of Affected Incumbents; And Amending The Department Allocation Tables Of The Auditor-Controller-Treasurer-Tax Collector's Office, The Department Of Health Services, The District Attorney's Office, The General Services Department, The Information Services Department, And The Sonoma County Water Agency, Effective November 13, 2018.

Whereas, at the October 16, 2018, meeting, the Civil Service Commission approved Human Resources' recommendation that one Accounting Manager, Auditor-Controller position be reclassified to Enterprise Financial System Manager, to appropriately address the full scope of assigned duties, with the retention of the incumbent in accordance with Civil Service Rule 3.3B; and

Whereas, one Animal Care Assistant allocation and one Animal Health Technician allocation, funded in the 2018-2019 adopted budget, were inadvertently removed from the Department of Health Services' adopted allocation list, necessitating their reinsertion; and

Whereas, the Department of Health Services also requests the addition of one time-limited Behavioral Health Clinical Specialist allocation and the deletion of one Public Health Nurse II allocation to better support the needs of its Mobile Support Team; and

Whereas, at the October 18, 2018, meeting, the Civil Service Commission approved Human Resources' recommendation that the Senior Legal Processor classification more appropriately represented the independence, scope, and consequence of error required of a studied Legal Processor II position in the District Attorney's Office, with the retention of the incumbent in accordance with Civil Service Rule 3.3B; and

Whereas, at the September 6, 2018, meeting, the Civil Service Commission approved Human Resources' recommendation that three Department Analyst positions be reclassified to a new Real Estate Project Specialist job classification in the General Services Department, to appropriately address the full scope of assigned duties, and that the incumbents be retained in accordance with Civil Service Rule 3.3B; and

Whereas, the Information Services Department has determined the need to add one Programmer Analyst allocation and delete one Mail, Materials & Records Handler II allocation to address the increased workload of the Web Team; and

Whereas, a classification study of three Sonoma County Water Agency positions represented by the International Union of Operating Engineers, Stationary Engineer – Local 39 (Local 39) conducted by Koff & Associates, a professional consulting firm, determined that one Automotive Mechanic position would be more appropriately classified as an Automotive Technician, and one Heavy Equipment Technician position would be more appropriately classified as a Lead Heavy Equipment Technician, with the retention of incumbents pursuant to Water Agency Personnel Policy, Article V – Reclassification; and

Whereas, the County Human Resources met, conferred, and came to agreement with Local 39 on these Water Agency classification study recommendations;

Now, Therefore, Be It Resolved that the reclassification of two Sonoma County Water Agency positions, with the retention of affected incumbents is approved; and the Department Allocation Tables of the Auditor-Controller-Treasurer-Tax Collector’s Office, the Department of Health Services, the District Attorney’s Office, the General Services Department, the Information Services Department, and the Sonoma County Water Agency are hereby revised as follows:

Budget Index	Job Class	Class Title	Existing Positions In Class	Change in Position Allocation	New Total Allocation For Class	Duration/ End Date	Salary Range
Auditor-Controller-Treasurer-Tax Collector’s Office							
11010101	0409	Enterprise Financial System Manager	0.0	1.0	1.0	Ongoing	5214
11010101	0438	Accounting Manager, Auditor-Controller	2.0	(-1.0)	1.0	Ongoing	4727
Department of Health Services							
22020106	4304	Animal Care Assistant	5.0	1.0	6.0	Ongoing	1489
22020106	4303	Animal Health Technician	5.0	0.5	5.5	Ongoing	2131
22030105	2503	Behavioral Health Clinical Specialist	10.00	1.0	11.0	6/30/2021	3742
22020105	2564	Public Health Nurse II	28.45	(-1.0)	27.45	Ongoing	3903
District Attorney’s Office							
18010101	0050	Senior Legal Processor	2.0	1.0	3.0	Ongoing	2193
18010101	0049	Legal Processor II	20.0	(-1.0)	19.0	Ongoing	1995
General Services Department							
21020300	0762	Real Estate Project Specialist	0.0	3.0	3.0	Ongoing	3704
21020300	0826	Department Analyst	9.0	(-3.0)	6.0	Ongoing	3226

Resolution #2

Date: November 13, 2018

Page 3

Information Services Department							
25010124	0130	Programmer Analyst	1.0	1.0	2.0	Ongoing	3502
25010151	0307	Mail, Materials & Records Handler II	7.0	(-1.0)	6.0	Ongoing	1984
Sonoma County Water Agency							
33010100	5228	Lead Heavy Equipment Technician	0.0	1.0	1.0	Ongoing	3228
33010100	5226	Heavy Equipment Technician	2.0	(-1.0)	1.0	Ongoing	2946
33010100	5223	Automotive Technician	0.0	1.0	1.0	Ongoing	2730
33010100	5222	Automotive Mechanic	1.0	(-1.0)	0.0	Ongoing	2690

Supervisors:

Gorin:

Rabbitt:

Zane:

Hopkins:

Gore:

Ayes:

Noes:

Absent:

Abstain:

So Ordered.

To: Maggie Miller, Principal Classification Analyst
County of Sonoma

From: Debbie Owen, Senior Project Manager, Koff & Associates

Subject: Sonoma County Water Agency
Classification Recommendation for Gary Breazeale, Automotive Mechanic

Date: May 30th, 2018

STUDY RECOMMENDATION

Koff & Associates (K&A) recommends that the position encumbered by Mr. Breazeale be reclassified to the classification of Automotive Technician.

STUDY BACKGROUND

K&A was retained by the Sonoma County Water Agency, a department within the County of Sonoma, ("County") to conduct a classification review of multiple positions, one of which was the position to which Mr. Breazeale is assigned.

Mr. Breazeale submitted a Position Description Questionnaire (PDQ) wherein he stated his working title is Light Fleet Mechanic. Mr. Breazeale considers his classification should be Light Fleet Lead Technician because his work is similar to a lead position in Fleet Operations.

A job evaluation interview with Mr. Breazeale was conducted on May 3rd, 2018.

POSITION ANALYSIS PROCESS

The following section provides narrative on each process task, with findings where applicable.

Position Description Questionnaire (PDQ) Review/Classification Interview

The duties and responsibilities assigned to the position as detailed in the PDQ (which was completed by the incumbent and signed by his supervisor) are presented below with approximate percentages of time spent on each task.

- Task 1 – Perform routine service on fleet vehicle, boats and equipment; document any equipment damage – 30%
- Task 2 – Diagnose minor and complex drivability problems and repair them – 10%
- Task 3 – Install, repair, and remove components such as GPS, radios, light bars, inverters, hitches and other equipment – 10%
- Task 4- Communicate with customers on scheduling and status of repairs and service needed – 10%



- Task 5 – Perform routine and complex computer data entry on daily work performed and retrieve data from previous repairs – 10%
- Task 6 – Supervise employees on basic care and light maintenance – 10%
- Task 7 – Order parts with Agency assigned credit card for medium and heavy fleet techs – 10%
- Task 8 – Research and recommend equipment and supporting technology.

Classification Specification Review

The Automotive Mechanic is an entry level classification; a review of the classification specification states that the classification “performs routing duties related to the preventive maintenance, overhaul, and repair of automobiles and light trucks.” The majority of tasks performed by Mr. Breazeale are included in the classification specification, but at the entry/trainee level and rather than the full working level at which Mr. Breazeale functions. Additionally, the following duties are exceptions, and are not represented in the specification:

- The classification specification does not reference boat maintenance.
- Mr. Breazeale orders parts, whereas the classification specification states that they determine parts needed for repair; as we understand it, Mr. Breazeale is assigned a Cal-Card to purchase parts for both the light and heavy vehicle operations, and presumably there are limits and conditions which must be adhered to.
 - Both of these tasks are within reasonable expectations of a journey level skilled technician and do not impact the nature of the assigned work.

STUDY FINDINGS/RECOMMENDATIONS

Mr. Breazeale considers that his position should be assigned to a lead level classification because he performs the same work as the shop foreman in Fleet Operations; he stated that the Fleet Operations position schedules vehicles for maintenance, and leads the work of five mechanic staff. As identified in task 6, Mr. Breazeale is responsible for directing the work of assigned staff who wash and vacuum vehicles, and/or perform minor preventive maintenance tasks each Friday.

The classification specification for the Automotive Technician does state that positions “may be assigned to train and serve as a technical resource for the work of Automotive Mechanics and interns”. The direction Mr. Breazeale provides to the staff washing and vacuuming vehicles on Fridays is covered under this statement; further, it is not the primary purpose of the job.

A contributing factor may be that his supervisor, Mr. Mitch Southard, works in a different location. While it is not uncommon that some supervisors are not in the same facility or location as the staff who report to them, this does mean that staff must be self-directed in handling day to day operational matters, as is the case for skilled technical staff. Nonetheless, it is possible that Mr. Breazeale and Mr. Southard do not have a shared understanding of supervisory accountabilities as it relates to the use of supplemental staff.

Koff & Associates (K&A) recommends that the position encumbered by Mr. Breazeale be reclassified to that of Automotive Technician. We do not consider that changes to the classification specification are necessary.

SUMMARY

This memorandum presents the process, methodologies and findings for Mr. Breazeale's position. If necessary, we can arrange to discuss any comments, concerns or issues arising from the content of this memorandum; I may be contacted at dowen@koffassociates.com.

Respectfully Submitted by:
Koff & Associates



Debbie Owen
Senior Project Manager

To: Maggie Miller, Principal Classification Analyst
County of Sonoma

From: Debbie Owen, Senior Project Manager, Koff & Associates

Subject: Sonoma County Water Agency
Classification Recommendation for Louie Lopez - Heavy Equipment Technician

Date: August 2th, 2018

STUDY RECOMMENDATION

Koff & Associates (K&A) recommends that the position encumbered by Mr. Lopez be assigned to the classification of Lead Heavy Equipment Technician.

STUDY BACKGROUND

K&A was retained by the Sonoma County Water Agency, a department within the County of Sonoma, ("County") to conduct a classification review of multiple positions, one of which was the position to which Mr. Lopez is assigned.

Mr. Lopez submitted a Position Description Questionnaire (PDQ) wherein he stated his working title is Heavy Equipment Mechanic II – it is our understanding that the actual classification is Heavy Equipment Technician.

Mr. Lopez considers his position should be assigned to the Heavy Equipment Fleet Maintenance Supervisor because of the additional tasks he performs outside the scope of his current classification.

A job evaluation interview with Mr. Lopez was conducted on May 3rd, 2018.

POSITION ANALYSIS PROCESS

The following section provides narrative on each process task, with findings where applicable.

Position Description Questionnaire (PDQ) Review/Classification Interview

The duties and responsibilities assigned to the position as detailed in the PDQ (which was completed by the incumbent and signed by his supervisor) are presented below with approximate percentages of time spent on each task.

- Task 1 – Corrective Maintenance – Replace a diverse range of failed or malfunctioning equipment such as transmissions, clutches, starters, alternators, injection and electric fuel pumps, brakes and their components, axle bearings and seals, air valves, and related equipment; troubleshoot, diagnose and resolve issues – 50%.
- Task 2 -Preventive Maintenance – Replace oil, filters, fan belts, lights, coolant hoses and related consumable replacement/general equipment maintenance work – 40%.

- In the meeting held by the consultant with his supervisor, Mr. Southard stated that preventive maintenance relative to corrective maintenance is approximately 70% of time spent, although he did not make that comment on the PDQ.
- It should also be noted that some work is outsourced based on a variety of factors.
- Task 3 – Administration – Create work orders; file a variety of reports such as CHP BIT inspection, and test results; review bid specifications and advise management – 5%
- Task 4 – Miscellaneous – Clean shop, order and pick up parts, conduct research – 5%.

In addition, at the beginning of the meeting, Mr. Lopez presented a list of duties which he performs which are outside the scope of the classification; it is not clear whether his supervisor was provided this list; however, the consultant did have a conversation with Mr. Southard on some of list tasks.

The additional tasks are outlined below; consultant notes are presented after each task.

- Coordinates with vendors for outsourced work.
 - K&A comment – While we note that this is a function performed by the Heavy Equipment Fleet Supervisor in Fleet Operations, in a small shop, this work would be one aspect of work for an advanced level classification provided other more complicated tasks were being performed.
- Manage warranty repairs and manufacturer recalls.
 - K&A comment – While we note that this is a function performed by the Heavy Equipment Fleet Supervisor in Fleet Operations, in a small shop, this work be one aspect of work for an advanced level classification provided other more complicated tasks were also being performed.
 - Given that this task was not on the original PDQ, we presume this task is not performed for a significant amount of time since neither he nor his supervisor referenced it.
- Main contact for heavy equipment repairs.
 - K&A comment – This would be within the scope of a journey level skilled technician classification, particularly in a smaller repair shop.
- Perform most complex mechanical repairs and determine best way to make repairs.
 - K&A comment – While work performed on heavy equipment would be an expectation of, and would be within the scope of, a journey level skilled technician classification, the work assignments in the shop include both medium and heavy equipment, as they presumably do in the central fleet shop. For that reason, the term “most complex mechanical repairs” would be difficult to assess if both positions performed an equal amount of work in both medium and heavy equipment. Based on our discussions with the employee and the supervisor, we do consider that the segregation of work assignments in the shop is predominantly medium equipment to Mr. Bettiga and heavy equipment to Mr.

Lopez. Therefore, Mr. Lopez is the only position working on heavy equipment as an ongoing accountability. If both positions are classified as Heavy Equipment Technicians, each of their workloads should reflect a combination of heavy and medium work assignments. We are advised that mechanical maintenance work performed on the sanitation vehicles and heavy construction equipment is primarily assigned to Mr. Lopez, and Mr. Bettiga is primarily assigned the medium heavy equipment repairs, and with the departure of an automotive technician, one-ton trucks/vehicles.

- Review work done by outside vendors; if not satisfied, explain reasons, then negotiate whether it's rework or additional cost.
 - K&A comment – While this would be within the scope of a journey level skilled technician classification; we anticipate that the Coordinator would be involved when monetary commitments which are beyond the authority of the Heavy Equipment Technician to commit to occur.
- Perform service writer functions; receive complaints; assess damage and diagnose mechanical failure
 - K&A comment – While we note that this is a function performed by the Heavy Equipment Fleet Supervisor in Fleet Operations, in a small shop, this work would be within the scope of work of a journey level skilled technician classification.
- Conduct safety meetings, review mechanical failures and safety issues with maintenance workers
 - K&A comment – While this is not called out in the classification specification, it is reasonable to expect that a mechanic who is skilled in specific equipment would be periodically called upon to demonstrate proper operating procedures and safety methods to end users as part of an overall safety program; however, we note that Mr. Lopez is the only classification incumbent performing those tasks and responsibility for safety is an advanced level task.
- Meet with truck manufacturers and body builders and draw up specifications for equipment purchases
 - K&A comment – See narrative on “Special Project” in the Study Findings/ Recommendation section.
- Fly out of state to equipment shows to see what's new in the industry or compare equipment
 - K&A comment – See narrative on “Special Project” in the Study Findings/ Recommendation section.
- Fly out of state to perform pre-inspections prior to the delivery of new equipment
 - K&A comment – See narrative on “Special Project” in the Study Findings/ Recommendation section.
- Manage the Agency's heavy diesel shop unsupervised for 23 years

- K&A comment – See narrative in the Study Findings/Recommendations section.
- Train maintenance workers proper operating procedures and techniques on heavy equipment
 - While this is not called out in the classification specification, it is reasonable to expect that a mechanic who is skilled in specific equipment would be periodically called upon to demonstrate proper operating procedures and safety methods to end users as part of an overall safety program; however, we note that Mr. Lopez is the only classification incumbent performing those tasks and responsibility for safety is an advanced level task.
- Agency mechanics are responsible for parts ordering, parts delivery, pick up parts and stocking inventory as well as supplies and materials.
 - K&A comment – This would be an expectation of a journey level skilled technician classification.

Classification Specification Review

A review of the classification specification for the Heavy Equipment Technician states that the classification “performs journey level work in the diagnosis, maintenance, overhaul and repair, and related work on on/off road equipment, trailers, medium and heavy duty trucks powered by a variety of fuel sources including diesel, gasoline, electric and alternative fuels.” Mr. Lopez performs most of the tasks within the classification specification.

The Heavy Equipment Fleet Maintenance Supervisor is a full supervisory level classification in the Heavy Equipment section of Fleet Operations; the predominant purpose of the classification is to exercise direct supervision over mechanic staff and coordinate overall shop operations.

Given the fact that Mr. Lopez is performing a combination of journey/advanced journey level tasks, we reviewed the classification of Lead Heavy Equipment Technician to determine whether this is a more comparable classification. The Distinguishing Characteristics of the class state:

“This is the advanced journey level in the Heavy Equipment class series responsible for assigning and reviewing the work of Heavy Equipment Mechanics, Technicians and interns in the Fleet Operations Division of the General Services Departments and to other County agencies. Incumbents coordinate and perform the most complex duties related to the preventive maintenance, overhaul and repair of medium/heavy duty trucks and on/off road equipment.”

STUDY FINDINGS/RECOMMENDATION

It is our assessment that the combination of journey/advanced journey duties performed by Mr. Lopez are more consistent with the Lead Heavy Equipment Technician classification. While Mr. Lopez does not oversee the work of Mr. Bettiga, other aspects of work complexity in the Lead Heavy Equipment Technician classification, such as training others (not staff overseen by the position, but staff who are responsible for equipment operations), performing the most complex repair duties on heavy equipment, California CHP BIT inspections, and general oversight of operations in the heavy equipment shop at the

Agency. While it is our understanding that it has been the department's stated intention to assign work between the two positions more equitably, for a variety of operational and business reasons, including increased workload demands for light equipment maintenance, that balanced distribution of work has not occurred over the years. While work imbalance is a management resource issue, the resulting impact becomes a classification issue if the work assignments for positions in the same classification are sufficiently different that one position performs more complex work for a prolonged period of time, which is the case here. We would like to state that this situation is not one which we would recommend continue, (i.e. the introduction and ongoing use of an advanced level classification in such a small shop), once the Agency has an opportunity to assign work in a more balanced manner.

We would like to address a specific issues raised by Mr. Lopez with respect to special projects, and how they impact work complexity:

- Special Project – These tasks were part of a project to which Mr. Lopez was assigned, as part of a team of Agency staff who were involved in the procurement of a new heavy vehicle for sanitation services which is valued at just under \$500,000. Other members of the team included the Maintenance Coordinator over sanitation services; Mr. Lopez's supervisor was not part of the team.

After speaking with Mr. Southard, who is Mr. Lopez's supervisor, we were advised that Mr. Lopez was asked to be on the team because he is a subject matter expert on the mechanical maintenance aspects of this equipment and his input was valuable in the process; however, other members of the team also brought different perspectives and/or expertise to the project; the approval process for the purchase was a management decision. He added Mr. Lopez did point out issues with the lube system on the vehicle, which resulted in a side contract which benefitted the Agency.

While the Agency does not purchase vehicles on a continuous basis, Mr. Lopez is asked periodically to research vehicles and specifications for proposed or new purchases. K&A recommends that these types of project requests be more properly documented and requested, so that he and his supervisor can have a shared understanding of the work he is performing in this area, and that clear direction be given to Mr. Lopez on his role in any new procurements or research requests.

No changes to the classification specification are necessary.

SUMMARY

This memorandum presents the process, methodologies and findings for Mr. Lopez's position. If necessary, we can arrange to discuss any comments, concerns or issues arising from the content of this memorandum; I may be contacted at dowen@koffassociates.com.

Respectfully Submitted by:
Koff & Associates





Debbie Owen
Senior Project Manager

To: Maggie Miller, Principal Classification Analyst
County of Sonoma

From: Debbie Owen, Senior Project Manager, Koff & Associates

Subject: Sonoma County Water Agency
Classification Recommendation for Tony Bettiga, Heavy Equipment Technician

Date: May 18th, 2018

STUDY RECOMMENDATION

Koff & Associates (K&A) recommends that the position encumbered by Mr. Bettiga remain in its current classification of Heavy Equipment Technician.

STUDY BACKGROUND

K&A was retained by the Sonoma County Water Agency, a department within the County of Sonoma, (“County”) to conduct a classification review of multiple positions, one of which was the position to which Mr. Bettiga is assigned.

Mr. Bettiga submitted a Position Description Questionnaire (PDQ) wherein he stated his working title is Heavy Equipment Mechanic II – it is our understanding that the classification is Heavy Equipment Technician. Mr. Bettiga did not express any concerns with respect to this classification.

A job evaluation interview with Mr. Bettiga was conducted on May 3rd, 2018.

POSITION ANALYSIS PROCESS

The following section provides narrative on each process task, with findings where applicable.

Position Description Questionnaire (PDQ) Review/Classification Interview

The duties and responsibilities assigned to the position as detailed in the PDQ (which was completed by the incumbent and signed by his supervisor) are presented below with approximate percentages of time spent on each task.

- Task 1 – Schedule vehicles to be worked on – 8%
- Task 2 – Service vehicles and their attachments – under hood compressors, welders, cranes – 70%
- Task 3 – Order parts – 1%
- Task 4 – Enter repairs made and money spent into the computer – 10%
- Task 5 – Pick up other vehicles to be serviced from other Agency yards – 10%

- Task 6 – Maintain licenses (Class A CDL, Water Treatment 1, Distribution Operator 1 – 1%

When asked about the types of equipment he works on, Mr. Bettiga explained that he is generally assigned the medium heavy equipment repairs; with the departure of an automotive technician, he has been assigned one-ton vehicles which might have otherwise been assigned to an automotive technician. However, because of work schedules which mean that the other heavy equipment technician is not available on Monday, Mr. Bettiga does need to know how to handle emergency maintenance situations for other heavy equipment.

Classification Specification Review

A review of the classification specification for the Heavy Equipment Technician states that the classification “performs journey level work in the diagnosis, maintenance, overhaul and repair, and related work on on/off road equipment, trailers, medium and heavy duty trucks powered by a variety of fuel sources including diesel, gasoline, electric and alternative fuels.” Mr. Bettiga performs most of the tasks within the classification specification.

His supervisor, Mr. Mitch Southard, who is the Coordinator for the group, confirmed that Mr. Bettiga works on the heavier utility trucks, and chippers and trailers, but does not work on the vac trucks which are more complicated. However, he considers the work is sufficiently similar and that the ultimate goal is to have enough overlap that all Heavy Equipment Technicians work on the same equipment; their shifts have been split up for that purpose.

STUDY FINDINGS/RECOMMENDATION

Koff & Associates (K&A) recommends that the position encumbered by Mr. Bettiga remain in its current classification of Heavy Equipment Technician. No changes to the classification specification are necessary.

SUMMARY

This memorandum presents the process, methodologies and findings for Mr. Bettiga’s position. If necessary, we can arrange to discuss any comments, concerns or issues arising from the content of this memorandum; I may be contacted at dowen@koffassociates.com.

Respectfully Submitted by:
Koff & Associates



Debbie Owen
Senior Project Manager

BOARD OF SUPERVISORS

AGENDA ADDENDUM

NOVEMBER 13, 2018

CONSENT CALENDAR

THE FOLLOWING ITEM IS BEING ADDED TO THE CONSENT CALENDAR:

COUNTY ADMINISTRATOR

21a. Recovery Update:

Receive update on the status of recovery operations, planning, seeking of funding opportunities, community engagement and status of recovery framework.

THE FOLLOWING ITEM IS BEING REMOVED FROM THE CONSENT CALENDAR:

AGRICULTURAL PRESERVATION AND OPEN SPACE DISTRICT

(Directors: Gorin, Rabbitt, Zane, Gore, Hopkins)

AND

REGIONAL PARKS

2. Wilroth Conservation Easement: Amendment to Conservation Easement:

A) Board of Directors: Adopt a Resolution making certain findings and (1) authorizing an amendment to the Wilroth Conservation Easement permitting the installation of an early warning fire camera on the property; and (2) authorizing the President of the Board to execute the easement amendment and all other documents to be recorded in connection with the easement amendment; and (3) delegating authority to the District's General Manager to take all necessary steps to effectuate the amendment of the easement.

B) Board of Supervisors: Consent to and authorize the Chair to execute the amendment to the Wilroth Conservation Easement as owner of a portion of the property subject to the Wilroth Conservation Easement that will not be impacted by the amendment.

(Unanimous Vote Required)(First District)



County of Sonoma Agenda Item Summary Report

Clerk of the Board
575 Administration Drive
Santa Rosa, CA 95403

Agenda Item Number: 3
(This Section for use by Clerk of the Board Only.)

To: Board of Directors of the Sonoma County Agricultural Preservation and Open Space District

Board Agenda Date: November 13, 2018

Vote Requirement: Majority

Department or Agency Name(s): Sonoma County Agricultural Preservation and Open Space District

Staff Name and Phone Number:

Jennifer Kuszmar, 565-7266
Misti Arias, 565-7264

Supervisorial District(s):

5

Title: Graton Green Matching Grant Project

Recommended Actions:

Adopt a resolution of the Board of Directors of the Sonoma County Agricultural Preservation and Open Space District making certain findings, approving a grant of up to \$103,124 for the Graton Green Matching Grant Project, authorizing the acquisition of a conservation easement and recreation covenant, and authorizing and directing the General Manager to take all other actions necessary to establish a conservation easement, recreation covenant and grant agreement.

Executive Summary:

During the 2016 Matching Grant Program cycle, the Board of Directors accepted the Graton Green Group's grant application to acquire property in Graton to become a public park known as "Graton Green". The Sonoma County Agricultural Preservation and Open Space District is proposing to execute a \$103,124 Matching Grant Agreement for the Graton Green with Graton Green Group, a California non-profit organization. The grant will be used to reimburse acquisition costs for a 0.5-acre property near the town center in the community of Graton that will be developed as the first public park in Graton. To protect Sonoma County Agricultural Preservation and Open Space District's investment, it will receive a Conservation Easement that will ensure that the conservation values of the property, such as urban open space, recreation and education, and scenic values will be preserved in perpetuity. The Sonoma County Agricultural Preservation and Open Space District will also receive a Recreation Covenant to ensure that the property remains open to the public in perpetuity.

Discussion:

Background

The Sonoma County Agricultural Preservation and Open Space District ("Ag + Open Space") offers a competitive Matching Grant Program ("Program") for projects that provide urban open space, creek restoration and enhancement, community recreation, and/or public access opportunities within and

near incorporated areas and other urbanized areas of Sonoma County. The Program is specifically authorized by the Expenditure Plan that was approved by the voters of Sonoma County in connection with the approval of Measure F in 2006.

In 2016, the Graton Green Group (“GGG”) submitted an application to the Program to acquire a 0.5-acre parcel that contains a tributary of Atascadero Creek and is bound by Bowen Street and Edison Street just one block from the commercial area in Graton. The purchase price for the proposed acquisition is \$168,648. In October of 2016, the Ag + Open Space Board of Directors accepted the project into the Program for an amount up to \$103,124 toward acquisition of the property. The GGG will provide the remaining \$69,524 in acquisition and related costs as its match. The remaining \$33,600 in matching funds will be used for initial park development by the current landowner and the GGG including plantings, grading, and development of a gathering space/stage under the water tower. GGG is purchasing the property from Orrin Theissen.

Property

The proposed park is a 0.5-acre area bordered by Edison Street to the east and Bowan Avenue to the west near the downtown area of the unincorporated community of Graton (“Property”). The Property is a newly-created parcel following an approved development known as Green Valley Village, which will create 10 single family lots which will open onto the Property to be known as Graton Green.

The Property is largely vacant and is dotted with oak and redwood trees. A tributary to Atascadero Creek runs along the southern boundary of the Property, where willow trees and riparian vegetation are found. A unique feature to the Graton Green is an abandoned water tower near Bowen Street. The water tower dates back to 1920. In 1987, the tank was removed but the steel structure remains and will be a focal point of the future park.

Matching Grant Program Project

The Graton Green will provide a public park and gathering space in the community. Once acquired, the land will be improved with riparian vegetation, landscaping, seating areas, pathways, a community garden and a stage beneath the old water tower (Project). The Project will also offer respite to cyclists using the West County Trail.

Matching Grant Agreement

As required under the Program guidelines, the Matching Grant Agreement requires that the Grantee provide a one-to-one match. GGG’s match of \$103,124 will be comprised of funding from community donations to the GGG, and in-kind contributions from Orrin Theissen’s company.

Ag + Open Space’s funding will be used for acquisition costs. Under the terms of the Matching Grant Agreement, the GGG must expend all matching funds for acquisition and open the park to the public by October 25, 2019.

Conservation Easement

In accordance with the Program Guidelines, all grant recipients are required to grant a Conservation Easement to Ag + Open Space. The Conservation Easement will protect the urban open space, natural

resources, recreation and education, and scenic values of the property in perpetuity by limiting use to public recreation and prohibiting all other subdivision and development.

Recreation Covenant

When Ag + Open Space funds are used to create public parks, recipients are required to execute a Recreation Covenant, which assures that the property will be available for public outdoor recreation in perpetuity.

Conformance with Adopted Plans

Sonoma County General Plan

The Project is consistent with the Sonoma County General Plan. Specifically, the Project implements several policies and objectives of the Open Space and Resource Conservation Element outlined in the Sonoma County General Plan 2020, including establishment of a countywide park and trail system that meets future recreational needs of the County's residents.

Expenditure Plan

The grant is consistent with the Ag + Open Space Expenditure Plan because it supports a recreation and urban open space project near unincorporated communities that links those communities. This project represents the creation of recreational opportunities in an unincorporated community that needs urban open space and is located along the West County Trail.

Connecting Communities and the Land, A Long-Range Acquisition Plan

The grant is consistent with Ag + Open Space's Long Range Acquisition Plan in furthering the Recreation and Education Objective to "work with partners to create and expand parks as part of a connected system of recreational lands." This project is a partnership with a non-profit committed to providing community open space in the community of Graton and further is adjacent to the West County Trail and will offer respite to those who use the trail.

California Environmental Quality Act

Pursuant to the California Environmental Quality Act (CEQA), Permit Sonoma prepared an initial study for Green Valley Village in accordance with the required CEQA statutes. On May 17, 2016 the Sonoma County Board of Supervisors adopted a mitigated negative declaration for Green Valley Village, a project which includes the park Project, finding the project will not result in any significant unavoidable environmental impacts. A Notice of Exemption will be filed for the acquisition of the Conservation Easement and the Recreation Covenant. Ag + Open Space's acquisition of the Conservation Easement and Recreation Covenants is categorically exempt from CEQA because the acquisition is not a project as defined in Section 15378 of Title 14 of the California Code of Regulations; alternatively it is exempt pursuant to Section 15317 of Title 14 of the California Code of Regulations because the purpose of the acquisition is to maintain the open space character of the area; and alternatively, it is exempt pursuant to Section 15325 (a) and (f) of Title 14 of the California Code of Regulations because the purpose of the acquisition is to preserve the existing natural conditions and open space for park purposes, respectively.

Sonoma County Open Space Fiscal Oversight Commission Review

On July 19, 2018, the Sonoma County Open Space Fiscal Oversight Commission approved Resolution No. 2018-006 determining that the appraisal is consistent with the Ag + Open Space guidelines and

standards and that Ag + Open Space is not paying more than fair market value for the Conservation Easement and Recreation Covenant that will be received as a condition of the funding provided for the Project.

2016 Matching Grant Program Budget

On October 25, 2016, the Board of Directors accepted seven projects totaling \$3,408,124 into the 2016 Program. The \$103,124 in funding for this project is budgeted for Fiscal Year 2018 – 2019.

Recommendation

Adopt a resolution of the Board of Directors of the Sonoma County Agricultural Preservation and Open Space District:

- 1) Determining that the project is consistent with the Sonoma County General Plan 2020 and the Sonoma County Agricultural Preservation and Open Space District’s Expenditure Plan;
- 2) Authorizing execution of a Matching Grant Agreement with the Graton Green Group, pursuant to which a \$103,124 grant will be made to the Graton Green Group for the Graton Green project;
- 3) Authorizing execution and acceptance of a Conservation Easement and Recreation Covenant;
- 4) Dedicating the conservation easement to open space purposes pursuant to Public Resources Code Section 5540; and
- 5) Directing the filing of a Notice of Exemption under the California Environmental Quality Act for the acquisition of the conservation easement pursuant to Title 14 of the California Code of Regulations Sections 15378, 15317, and 15325 (a) and (f).

Prior Board Actions:

October 25, 2016: Board of Directors of the Agricultural and Open Space District accepted the Graton Green project into the Program. *Board Action #19*

May 17, 2016: Board of Supervisors approved the Green Valley Village subdivision, general plan amendment and zone change. *Resolution #16-0201*

Strategic Plan Alignment Goal 1: Safe, Healthy, and Caring Community

The project will promote a healthy community by providing a new park space in a geographically underserved community.

Fiscal Summary			
Expenditures	FY 18-19 Adopted	FY 19-20 Projected	FY 20-21 Projected
Budgeted Expenses	\$103,124	\$0	\$0
Additional Appropriation Requested			
Total Expenditures	\$103,124		
Funding Sources			
General Fund/WA GF			
State/Federal			
Fees/Other	\$103,124		
Use of Fund Balance			
Contingencies			
Total Sources	\$103,124		
Narrative Explanation of Fiscal Impacts:			
There are adequate appropriations in the FY18-19 budget for this matching grant.			
Staffing Impacts			
Position Title (Payroll Classification)	Monthly Salary Range (A – I Step)	Additions (Number)	Deletions (Number)
Narrative Explanation of Staffing Impacts (If Required):			
Attachments:			
<ol style="list-style-type: none"> 1. General Plan Location Map 2. Location Map 3. Graton Green Master Plan (draft) 4. Resolution 			
Related Items "On File" with the Clerk of the Board:			
<ol style="list-style-type: none"> 1. Matching Grant Agreement 			

2. Conservation Easement
3. Recreation Covenant
4. Notice of Exemption

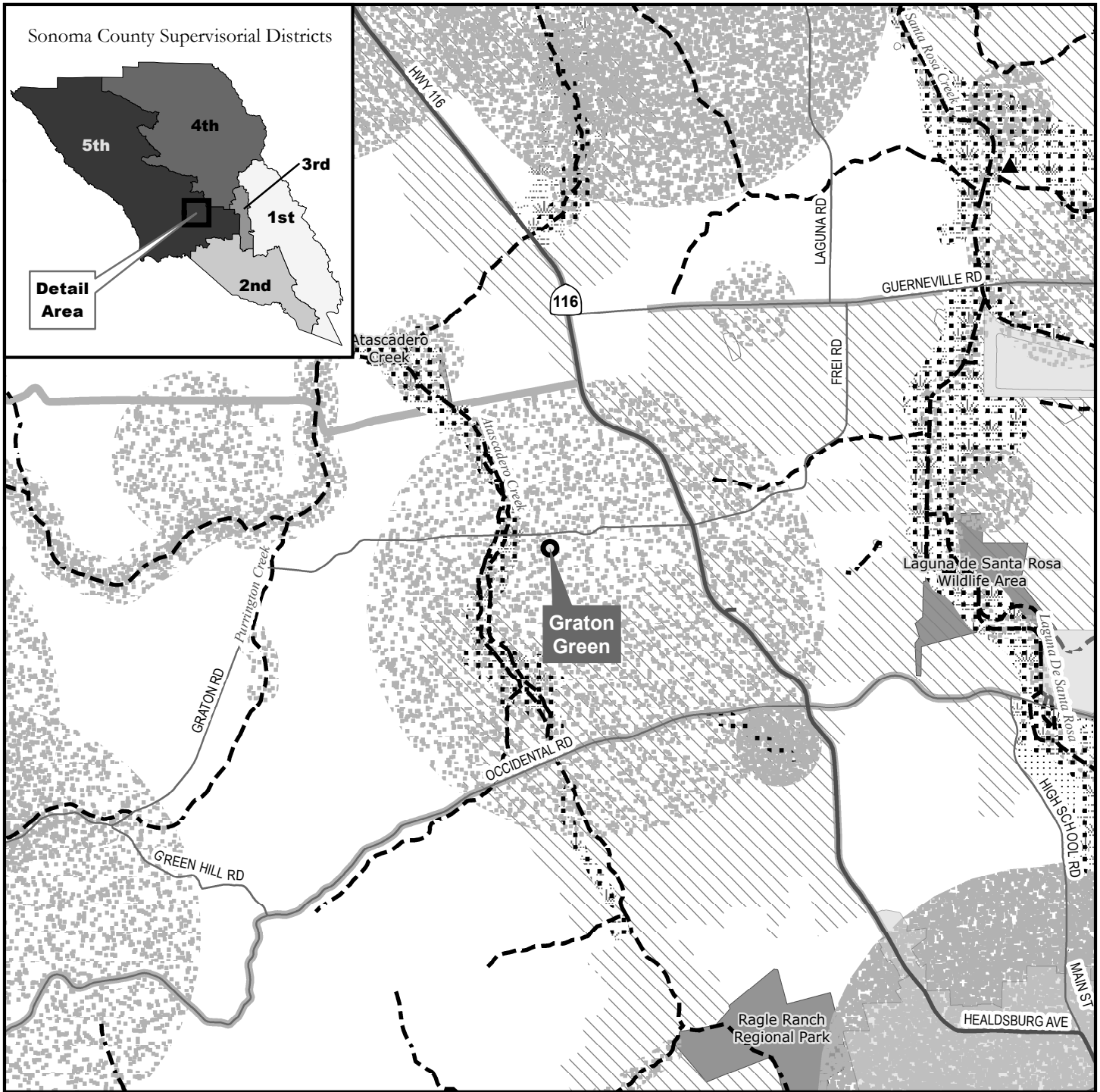

Sonoma County Supervisorial Districts

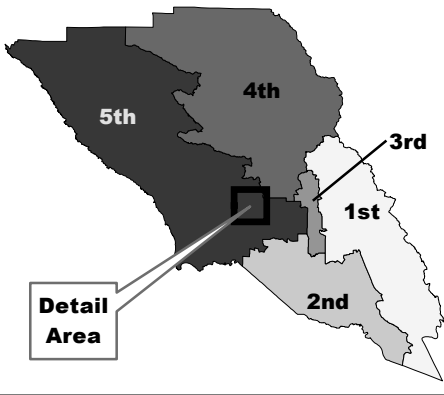

Graton Green

LOCATION / GENERAL PLAN MAP

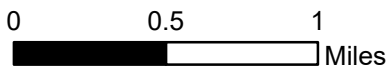

Map Date: 10/24/2018
 Sources: Sonoma County GIS Group;
 Sonoma County General Plan 2020,
 Open Space and Resource
 Conservation Element.
 This map is for illustrative
 purposes only.

Open Space and Resource Conservation Element

- Graton Green
- Incorporated City Land
- District Holding
- Public Land
- SCENIC RESOURCES**
- Community Separator
- Scenic Landscape Unit
- Scenic Corridor
- OUTDOOR RECREATION**
- Planned Future Park
- BIOTIC RESOURCES**
- Riparian Corridor
- Special Status Species Habitat
- Marshes and Wetlands
- Sensitive Natural Communities
- Habitat Connectivity Corridor *

* Not on this map

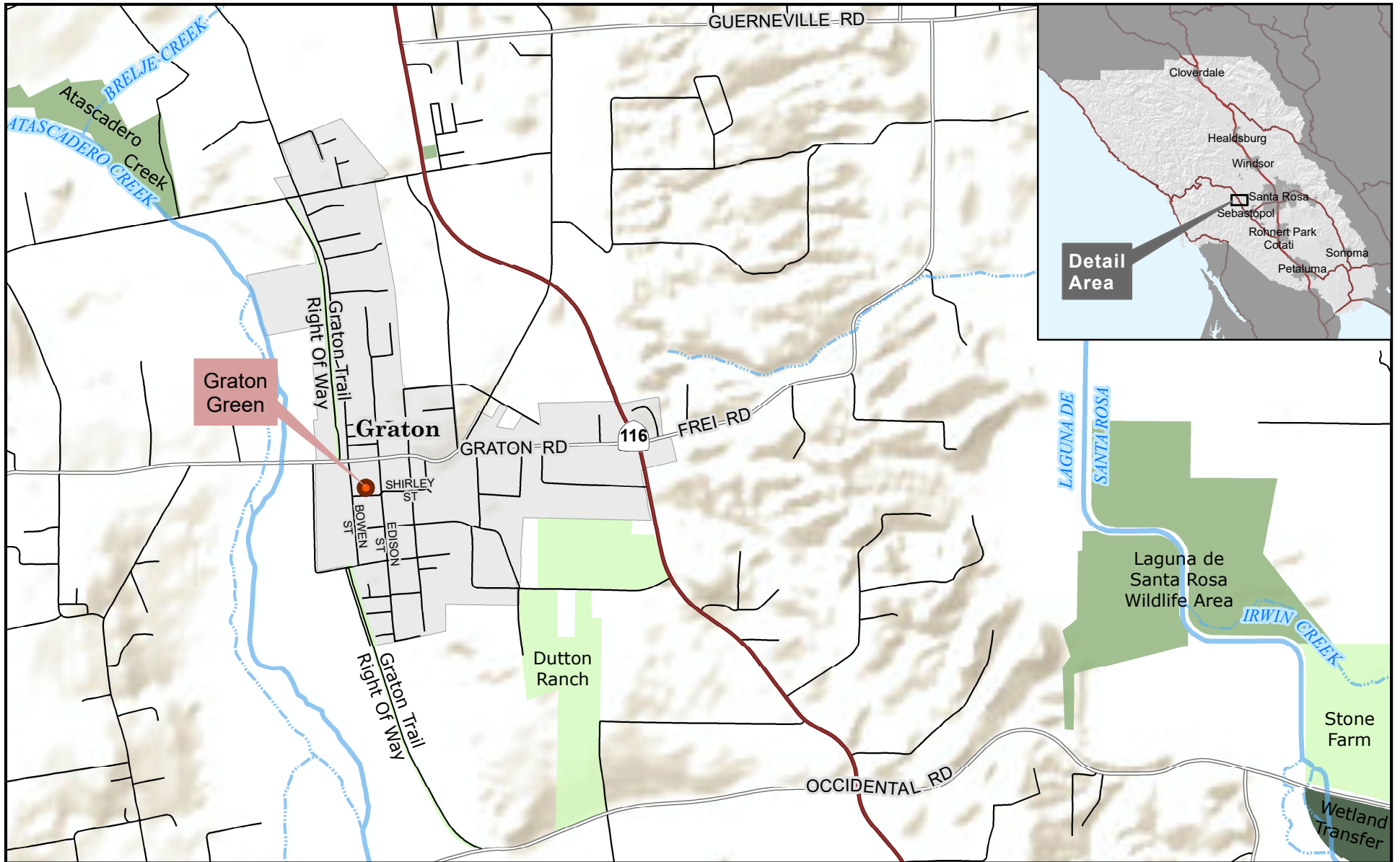

Graton Green Location Map

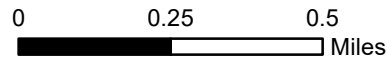

- | | | |
|---------------------|--------------------------------|--------------------|
| Perennial Waterway | District Fee Title | Graton Green |
| Intermittent Stream | District Conservation Easement | Urban Service Area |
| | Other Protected Land | |

Map Date: 10/24/2018
 Sources: CPAD (protected lands); SCWA (streams); County GIS (roads, communities)
 This map is for illustrative purposes only: it is not a property description.

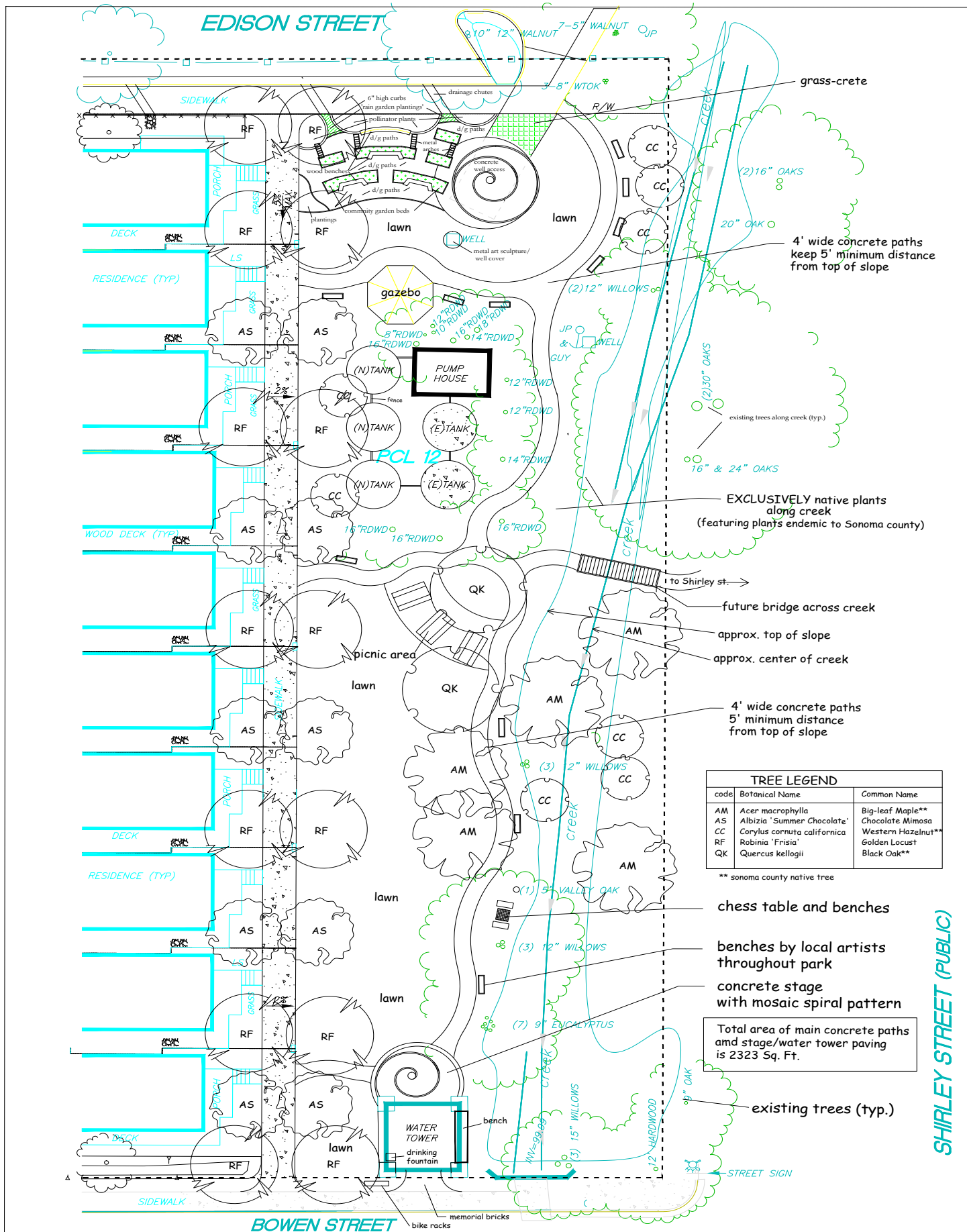

TREE LEGEND		
code	Botanical Name	Common Name
AM	Acer macrophylla	Big-leaf Maple**
AS	Albizia 'Summer Chocolate'	Chocolate Mimosa
CC	Corylus cornuta californica	Western Hazelnut**
RF	Robinia 'Frisia'	Golden Locust
QK	Quercus kelloggii	Black Oak**

** sonoma county native tree

SHIRLEY STREET (PUBLIC)

Conceptual Plan
Scale: 1"=10'

Graton Park

Revised 6-27-18

Date: November 13, 2018

Item Number: _____
Resolution Number: _____

4/5 Vote Required

Resolution of the Board of Directors of the Sonoma County Agricultural Preservation and Open Space District Making Certain Findings and Approving a \$103,124 Matching Grant to the Graton Green Group for the Acquisition of a Certain 0.5 acre Property Located at 3000 Edison Street in the Unincorporated Area of Graton; Authorizing Execution of a Matching Grant Agreement; Authorizing Execution and Acceptance of a Conservation Easement and Recreation Covenant; Delegating the Certain Duties to the General Manager and Directing the filing of a Notice of Exemption under CEQA.

Whereas, the Sonoma County Agricultural Preservation and Open Space District (“the District”) offers a competitive Matching Grant Program (“the Program”) for projects that provide urban open space, creek restoration and enhancement, community recreation, and/or public access opportunities within and near incorporated areas and other urbanized areas of Sonoma County; and

Whereas, the Program requires applicants to provide a matching contribution for the project funding; and

Whereas, on March 25, 2016, the Board of Directors of Graton Green Group authorized the submission of a Matching Grant Program application for the acquisition and development of a 0.5-acre park in Graton (“the Property”); and;

Whereas, the Property will be improved with riparian vegetation, landscaping, seating areas, pathways, a community garden, and a stage (“the Project”)

Whereas, on October 25, 2016, the District’s Board of Directors approved the joint recommendation from staff and the District’s Advisory Committee to accept the Project application and approve up to \$103,124 in funding towards the Project contingent upon execution of a Matching Grant Agreement; and

Whereas, as a condition of funding, the Graton Green Group must grant the District a Conservation Easement and a Recreation Covenant on the Property, pursuant to which

Resolution #

Date:

Page 2

the Graton Green Group will accept the affirmative obligation to protect the conservation values of the Property and to use, operate and maintain the Property for public outdoor recreation in perpetuity.

Now, Therefore, Be It Resolved that this Board of Directors hereby finds, determines, declares, and orders as follows:

1. **Truth in Recitals.** That the foregoing recitations are true and correct.
2. **General Plan Consistency.** That the Project is consistent with the Sonoma County General Plan 2020, specifically the Open Space and Resource Conservation element, (OSRC Goal 17).
3. **Expenditure Plan Consistency.** That the Project is consistent with the Sonoma County Agricultural Preservation and Open Space District's Expenditure Plan, as it states that sales tax monies may be spent on urban open space and recreation projects within and near incorporated areas and other urbanized areas of Sonoma County, including, but not limited to creek restoration and enhancement, trails, athletic fields, and urban greenspace.
4. **Conservation Easement and Certificate of Acceptance.** That the President is authorized and directed to execute, on behalf of the District, that certain agreement in connection with the Project entitled "Deed of Conservation Easement and Agreement By and Between the Graton Green Group and the Sonoma County Agricultural Preservation and Open Space District" ("Conservation Easement"), together with the certificate of acceptance required by Government Code section 27281.
5. **Recreation Covenant and Certificate of Acceptance.** That the President is authorized and directed to execute, on behalf of the District, that certain agreement in connection with the Project entitled "Graton Green Recreation Conservation Covenant" ("Recreation Covenant"), together with the Certificate of Acceptance required by Government Code section 27281.
6. **Authority to Sign Grant Agreement.** That the District's General Manager is authorized to execute that certain agreement in connection with the Project entitled "Graton Green Matching Grant Agreement" between the Sonoma County Agricultural Preservation and Open Space District and the Graton Green Group Incorporated, a non-profit corporation. ("Matching Grant Agreement").
7. **Payment of Grant Funds.** That, subject to the provisions of the Matching Grant Agreement, at the request of the General Manager, the County Auditor shall draw a warrant or warrants against available funds in the District's Land Acquisition Fund in amounts, cumulatively, not to exceed \$103,124.

All expenditures under this Paragraph 5 are subject to the following:

- i. No expenditures shall be made until the Conservation Easement is fully executed and recorded in the office of the Sonoma County Recorder.
- ii. No expenditures shall be made until the Matching Grant Agreement is fully executed.
- iii. Expenditures shall be made only upon a determination by the District's General Manager, or his designee, that the expenditure is for reimbursement of the Project's costs that are reasonable and necessary to the District Grant Project as approved.
- iv. The District's General Manager is hereby authorized to approve and pay claims that are submitted and reviewed in accordance with this Resolution, and the Matching Grant Agreement, and that he finds to have been reasonably and necessarily incurred in connection with the Project as approved.

8. Delegation to Finalize and Record Documents. That the General Manager is authorized to make technical, non-substantive changes in the Matching Grant Agreement, Conservation Easement, and Recreation Covenant with the prior approval of the District's Counsel. The General Manager is further authorized and directed to record with the Sonoma County Recorder the Conservation Easement and the Recreation Covenant and to deliver conformed copies of these documents, bearing evidence of recording, to the Clerk of the Board of Directors.

9. Dedication. That the Conservation Easement to be acquired is hereby dedicated to open space purposes pursuant to Public Resources Code Section 5540.

10. California Environmental Quality Act. Pursuant to the California Environmental Quality Act (CEQA), the County of Sonoma on behalf of Permit Sonoma adopted Mitigated Negative Declaration for the Green Valley Village, which included the Graton Green Project. The District's acquisition of the Conservation Easement and Recreation Covenant over the Property is categorically exempt from CEQA because the acquisition is not a project as defined in Section 15378 of Title 14 of the California Code of Regulations; alternatively it is exempt pursuant to Section 15317 of Title 14 of the California Code of Regulations because the purpose of the acquisition is to maintain the open space character of the area; and alternatively, it is exempt pursuant to Section 15325 (a) and (f) of Title 14 of the California Code of Regulations because the purpose of the acquisition is to preserve the existing natural conditions and open space for park purposes, respectively.

Resolution #

Date:

Page 4

11. Posting. Immediately upon adoption of this resolution, the General Manager is directed to file with the County Clerk and the County Clerk is directed to post and to maintain the posting of a notice of exemption pursuant to Public Resources Code Section 21152.

Supervisors:

Gorin:

Rabbitt:

Zane:

Hopkins:

Gore:

Ayes:

Noes:

Absent:

Abstain:

So Ordered.



County of Sonoma Agenda Item Summary Report

Clerk of the Board
575 Administration Drive
Santa Rosa, CA 95403

Agenda Item Number: 4
(This Section for use by Clerk of the Board Only.)

To: Board of Directors, Sonoma County Agricultural Preservation and Open Space District

Board Agenda Date: November 13, 2018

Vote Requirement: Majority

Department or Agency Name(s): Sonoma County Agricultural Preservation and Open Space District

Staff Name and Phone Number:

Stuart Martin, 565-7362

Supervisorial District(s):

District 2

Title: Mattos Dairy SALCP Grant Agreement

Recommended Actions:

Approve resolution of the Directors of the Sonoma County Agricultural Preservation and Open Space District (a) ratifying the submission of an application to the State of California Department of Conservation for a \$750,000 grant under the Sustainable Agricultural Lands Conservation Program towards acquisition of a conservation easement, (b) authorizing the Board President to sign a letter certifying that there is no known conflict of interest, or the appearance of a conflict of interest, for the Board or any of its members with respect to the proposed funding, and (c) authorizing the General Manager to sign the Sustainable Agricultural Lands Conservation Program Grant Agreement for the Mattos Dairy conservation easement project.

Executive Summary:

The Sonoma County Agricultural Preservation and Open Space District has applied for and has been awarded a \$750,000 grant from the California State Department of Conservation through the Sustainable Agricultural Lands Conservation Program. The grant is to assist the District in the acquisition of the Mattos conservation easement to protect a productive 700.92-acre pasture ranch in the Two Rock Valley. Sonoma County Agricultural Preservation and Open Space District staff is requesting the Board to ratify the grant application, to have the Board President sign the no conflict of interest letter, and to authorize the General Manager to enter into the grant agreement.

Discussion:

The Sustainable Agricultural Lands Conservation Program ("SALCP" or "Program") is a new State grant program of the Strategic Growth Council to support the State's greenhouse gas emission goals by making strategic investments to protect agricultural lands. SALCP is part of the State's Affordable Housing and Sustainability Program ("AHSC"), which aims "to reduce greenhouse gas emissions through projects that implement land use, housing, transportation, and agricultural land preservation practices

to support infill and compact development." Protecting critical agricultural lands from conversion to urban or rural residential development promotes smart growth within existing jurisdictions, ensures that open space remains available, and supports a healthy agricultural economy and resulting food security.

The Program is administered by the State Department of Conservation ("DOC"). It provides funding to leverage the protection of strategically-located, highly-productive, and critically-threatened agricultural land via permanent agricultural conservation easements in order to avoid increases in greenhouse gas emissions associated with conversion of agricultural lands, consistent with AB 32: the California Global Warming Solutions Act of 2006.

On April 27, 2016, Sonoma County Agricultural Preservation and Open Space ("Ag + Open Space") submitted an application to the State for a \$750,000 grant under the Program to assist with the acquisition of the Mattos conservation easement. On August 9, 2016, the Strategic Growth Council awarded the grant. Since then, the District has been negotiating the terms and conditions of the conservation easement, and has been going through the appraisal process. Due to the timing of the grant application period in relationship to our acquisition process, District staff submitted the application prior to bringing it to the Board. The match requirement is 50 percent (\$375,000), which the Ag + Open Space would fund. Additionally, the State requires certification that there is no known conflict of interest, or appearance of a conflict of interest, for the Board or any of its members with respect to the proposed acquisition of an agricultural conservation easement on the Mattos Dairy, and proposed funding from the Sustainable Agricultural Lands Conservation Program.

The 700.92-acre Mattos Dairy is located south of the city of Cotati off Meacham and Pepper Roads, within the Ag + Open Space priority conservation Coastal Agriculture focus area. The property supports two working dairies run by the Mattos family. The proposed conservation easement project will protect agricultural land and thus contribute to carbon sequestration in the grassland soils and oak woodlands on the property. In addition, the conservation easement will restrict conversion of the land to urban or suburban uses - uses that would increase greenhouse gas emissions.

Ag + Open Space is currently in negotiations with the property owner regarding the final conservation easement terms and the acquisition price of the conservation easement. In order to comply with the Program's grant cycle deadlines, the SALCP grant agreement must be executed by November 15, 2018. Under the terms of the grant agreement, Ag + Open Space will have two years in which to expend the grant funds. In the event that Ag + Open Space and the property owner are unable to reach agreement, the funds will revert back into the SALCP. District staff is confident we will reach agreement with the property owners in the near future, and close prior to the grant deadline.

The Board will have the opportunity to consider the conservation easement project as a whole once we have completed the negotiation and appraisal process, and executed the grant agreement.

In order to complete the application for a SALCP grant, District staff recommends that the Board adopt the attached resolution to:

- (1) Ratify the submission of the application to the State of California Department of Conservation for a grant under the Sustainable Agricultural Lands Conservation Program, and

- (2) Authorize the Board President to sign a letter that certifies that there is no known conflict of interest, or the appearance of a conflict of interest, for the Board or any of its members with respect to the proposed funding from the Department of Conservation’s Sustainable Agricultural Lands Conservation Program for the Mattos Dairy, and
- (3) Authorize the General Manager to sign and execute the grant agreement.

Prior Board Actions: none

Strategic Plan Alignment Goal 2: Economic and Environmental Stewardship

The project protects, restores and maintains public lands and open space systems that promote recreation, health, agricultural viability and protects watersheds, promotes biodiversity and contributes to the area’s economic vitality.

Fiscal Summary

	FY 18-19 Adopted	FY 19-20 Projected	FY 20-21 Projected
Expenditures			
Budgeted Expenses	0	0	0
Additional Appropriation Requested			
Total Expenditures	0	0	0
Funding Sources			
General Fund/WA GF			
State/Federal			
Fees/Other			
Use of Fund Balance			
Contingencies			
Total Sources	0	0	0

Narrative Explanation of Fiscal Impacts:

The Mattos Dairy project is budgeted for FY 18-19, however, consideration of the purchase of the conservation easement will be brought to the Board in the future.

Staffing Impacts

Position Title (Payroll Classification)	Monthly Salary Range (A – I Step)	Additions (Number)	Deletions (Number)

Narrative Explanation of Staffing Impacts (If Required):

Attachments:

1. Location Map
2. Board Resolution
3. Draft no conflict letter

Related Items "On File" with the Clerk of the Board:

1. Draft grant agreement
2. Grant application

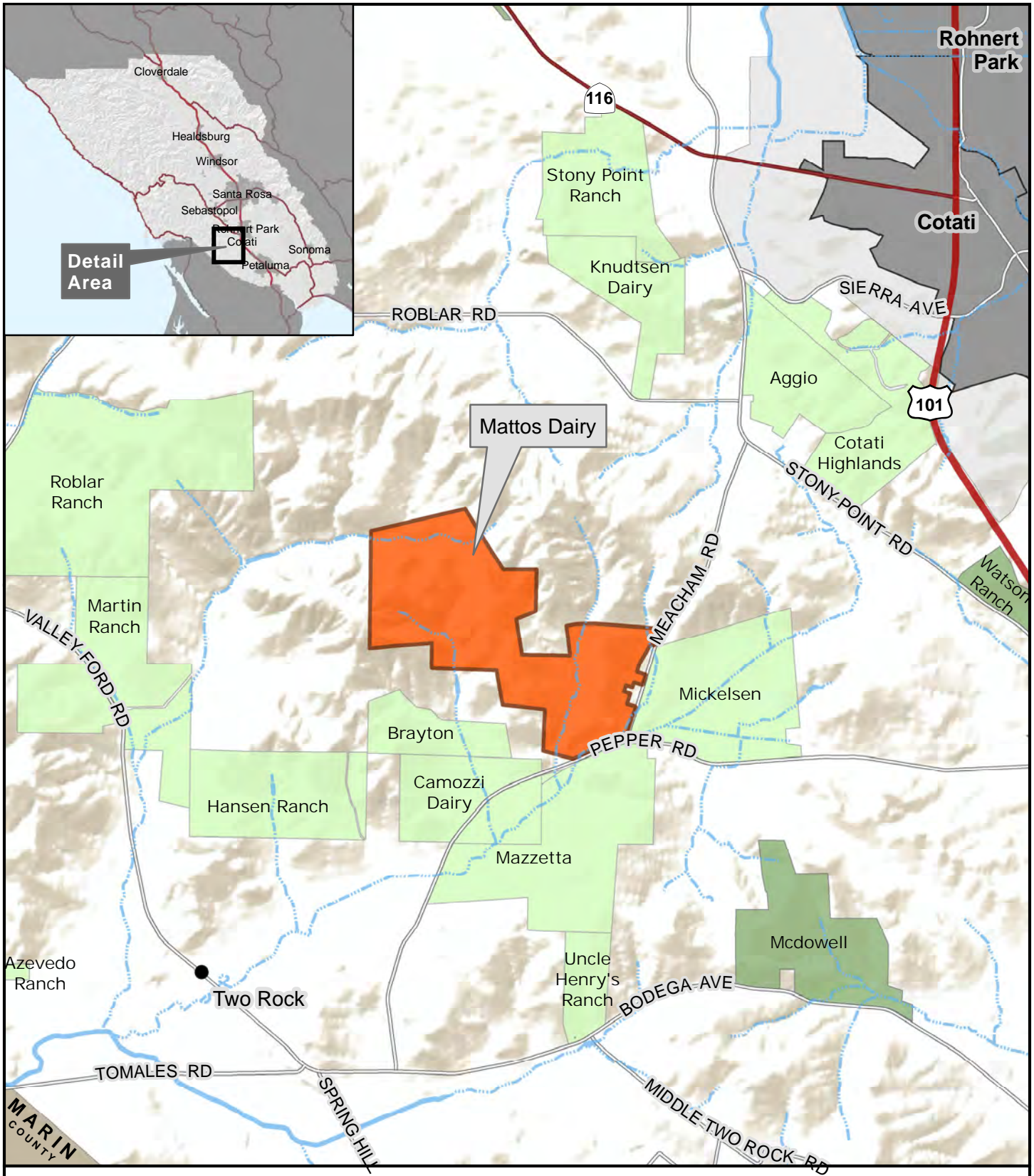

Mattos Dairy Location Map



AG + OPEN SPACE
SONOMA COUNTY

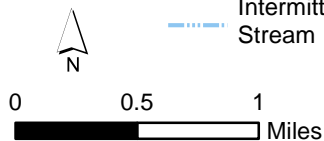

- Perennial Waterway
- - - Intermittent Stream
- Mattos Dairy
- District Conservation Easement
- Other Protected Land
- Incorporated City
- Urban Service Area

Map Date: 4/11/2018
Sources: CPAD (protected lands); SCWA (streams); County GIS (roads, communities)
This map is for illustrative purposes; it is not a definitive property description.

Date: November 13, 2018

Item Number: _____
Resolution Number: _____

4/5 Vote Required

Resolution Of The Board Of Directors Of The Sonoma County Agricultural Preservation and Open Space District, County Of Sonoma, State Of California, (1) Ratifying The Submission of An Application to the California Department of Conservation For A Grant Under The State Sustainable Agricultural Lands Conservation Program, (2) Certifying That There Is No Known Conflict of interest, Or The Appearance Of A Conflict of Interest, For The Board Or Any Of Its Members With Respect To The Proposed Funding From The Sustainable Agricultural Lands Conservation Program For Mattos Ranch, and (3) Authorizing The District General Manager To Sign And Execute The Sustainable Agricultural Lands Conservation Program Grant Agreement For Acquisition of a Conservation Easement Over the Mattos Dairy.

Whereas, the California Legislature has established the Sustainable Agricultural Lands Conservation Program which is administered by the Department of Conservation, and through a grant program is providing assistance to conserve important agricultural land resources that are subject to conversion pressures; and

Whereas, the District intends to negotiate an agricultural conservation easement over the 700.92 acre Mattos Ranch located southwest of the city of Cotati at 602 Hammel Road, Petaluma, CA for the purpose of conserving priority agricultural land resources; and

Whereas, the property is located within a District-identified Coastal Agriculture priority conservation area; and

Whereas, District staff has submitted an application to the Department of Conservation for a grant under the Sustainable Agricultural Lands Conservation Program to assist with the preservation of Mattos Ranch agricultural land resources; and

Whereas, the Board of Directors desires to ratify the submission of said application to the Department of Conservation and make certain finding required by the State in connection with applications for grants under the Sustainable Agricultural Lands Conservation Program.

Now, Therefore, Be It Resolved that this Board of Directors hereby finds, determines, declares and orders as follows:

1. *Truth of Recitals.* That the foregoing recitations are true and correct.

Resolution #

Date:

Page 2

2. *Ratification of Grant Application.* That the Grant Application submitted to the Department of Conservation by District Staff on April 27, 2016, seeking a grant under the Sustainable Agricultural Lands Conservation Program is hereby ratified and authorized by the Board.

3. *No Conflict of Interest.* That no known conflict of interest, or the appearance of a conflict of interest, exists for the Board or any of its members as related to the proposed acquisition of an agricultural conservation easement on the Mattos Ranch, with proposed funding from the Sustainable Agricultural Lands Conservation Program.

4. *Potential Future Conflict of Interest.* That at any time in the future once the conservation easement is in place, should a Board member have a conflict of interest related to the Mattos Ranch, such Board member shall recuse him or herself from all discussions and voting related to monitoring and enforcement of the conservation easement.

5. *Authority to Enter into Agreements, Accept Grant, Sign Invoices.* That the General Manager is authorized and directed to conduct all negotiations, and to execute and submit that certain grant agreement #SALCP15_APP2_SON with the California Department of Conservation's Sustainable Agricultural Lands Conservation Program for \$750,000 to assist in the cost of acquiring an agricultural conservation easement over the Mattos Dairy; to sign invoices requesting disbursement of the grant; and to execute other documents related to the grant.

Directors:

Gorin:

Rabbitt:

Zane:

Hopkins:

Gore:

Ayes:

Noes:

Absent:

Abstain:

So Ordered.



November 13, 2018

Sustainable Agricultural Lands Conservation Program
Division of Land Resource Protection
California Department of Conservation
801 K Street, MS 18-01
Sacramento, CA 95814

To Whom It May Concern:

As certified by Resolution No. _____ of the Board of Directors of the Sonoma County Agricultural Preservation and Open Space District, no known conflict of interest, or the appearance of a conflict of interest, exists for the Board or any of its members as related to the proposed acquisition of an agricultural conservation easement on the Mattos Dairy, with proposed funding from the Sustainable Agricultural Lands Conservation Program.

Furthermore, at any time in the future once the conservation easement is in place, should a Board member have a conflict of interest related to the Mattos Dairy, such Board member shall recuse him or herself from all discussions and voting related to monitoring and enforcement of the conservation easement.

James Gore, President
Sonoma County Agricultural Preservation and Open Space District



County of Sonoma Agenda Item Summary Report

Clerk of the Board
575 Administration Drive
Santa Rosa, CA 95403

Agenda Item Number: 5
(This Section for use by Clerk of the Board Only.)

Board of Supervisors
Board of Commissioners of the Community Development Commission

Board Agenda Date: November 13, 2018

Vote Requirement: Majority

Department or Agency Name(s): Sonoma County Community Development Commission

Staff Name and Phone Number:

Jenny Abramson, 707-565-7548
Chuck Mottern, 707-565-7554

Supervisory District(s):

All

Title: Santa Rosa Armory Temporary Overnight Winter Shelter Program

Recommended Actions:

- 1) Authorize the Executive Director of the Community Development Commission to execute on behalf of the County of Sonoma a License Agreement with the California Military Department for the use of the Santa Rosa National Guard Armory as a temporary overnight homeless shelter.
- 2) Authorize the Executive Director of the Community Development Commission to execute an agreement with St. Vincent De Paul – Sonoma to operate a temporary overnight homeless shelter.

Executive Summary:

This item seeks authorization for the Executive Director of the Community Development Commission (Commission) to execute the agreements necessary to utilize the Santa Rosa National Guard Armory as a temporary overnight homeless shelter during the winter of 2018-19. In 2017, Supervisor Zane and St. Vincent De Paul-Sonoma negotiated an arrangement with the California Military Department to utilize the National Guard Armory in Santa Rosa as a temporary overnight homeless shelter. Given the Shelter Emergency Declaration issued by the Board on October 9th in response to the growing frequency of homelessness, the Commission recommends again providing additional winter shelter for those experiencing homelessness during the months of November through March.

Discussion:

According to the 2018 Sonoma County Point-in-Time Homeless Count, on any given night there are nearly 3,000 unsheltered persons across Sonoma County. While the Commission has taken additional action to expand Emergency Shelter capacity during the winter months between November and March, some unsheltered persons may benefit from having additional shelter options to escape the seasonally cold and wet weather.

After the 2017 Sonoma Complex Fire, additional measures were necessary to get as many people as possible out of the cold during the winter nights. To address this need, St. Vincent De Paul-Sonoma and Supervisor Zane reached out to the Governor’s Office regarding the use of the Armory. The St. Vincent De Paul-Sonoma Board of Directors agreed to cover the operational costs of the shelter. That winter, the Armory Winter Shelter provided more than 3,000 bed nights of safe overnight shelter and hot meals to 202 people over the course of its ten weeks of operation, January 4 through March 16, 2018. Almost all were persons with disabilities who had lengthy homelessness. Up to 80 people were served each night.

The 2018 Point-in-time Count showed a continued need for increased shelter beds during the winter months. St. Vincent De Paul-Sonoma has agreed to again operate the project for Winter 2018-2019. Under California Law, the State Military Department can only license the use of the Armory to a city or county government. Therefore the execution of the license agreement by Sonoma County is necessary to enable the shelter operations to occur again during the Winter of 2018-2019.

While the use of the Armory as a winter shelter has previously presented challenges, and the program model is not consistent with the Housing First philosophy and supportive services model the County supports, the need to offer increased shelter remains. Until more permanent options are available for getting out of the weather, The Commission recommends executing the necessary agreement to use the Armory as a shelter, providing approximately 80 additional shelter beds in the County nightly from November 19th to March 3rd.

License Agreement and Operator Agreement

Two agreements are necessary to enable the use of the Armory as a temporary winter shelter. The first is a License Agreement with the California Military Department. The second is an Operator Agreement with St. Vincent De Paul. Highlights of the provisions include:

- Dates of operation, November 19th to March 3rd
- Hours of operation limited to 5:30 p.m. to 7:30 a.m.
- During holidays, the shelter will continue to operate at typical hours
- The premises are not available during drill periods
- The use fee is \$540 for each 14 hour period
- Insurance coverage of \$2,000,000 and hold harmless indemnification are required
- A security guard must be present during hours of use

All of the provisions required by the License Agreement will be passed on to St. Vincent De Paul-Sonoma, including all the insurance requirements, coverage of any damage costs, and rental payments made directly to the state. St. Vincent De Paul has also created an Operational Plan that provides the details related to the delivery of the shelter services, included as Attachment C. The Commission will ensure the proper execution of both agreements before commencing the use of the Armory.

Prior Board Actions:

10/9/2018, Item #27 – Authorized revised Declaration of Shelter Crisis.

12/12/2017, Item #43 – Authorized License Agreement with National Guard for use of the Santa Rosa Armory as a temporary overnight homeless shelter, and an agreement with St. Vincent de Paul-Sonoma to operate the shelter.

Strategic Plan Alignment Goal 1: Safe, Healthy, and Caring Community

Winter shelters provide basic protection from the elements during the coldest and wettest months of the year. They protect the safety and health of residents who are experiencing a housing crisis. At their best, winter shelters also link participants to additional services that may assist them to end that crisis.

Fiscal Summary

Expenditures	FY 18-19 Adopted	FY 19-20 Projected	FY 20-21 Projected
Budgeted Expenses			
Additional Appropriation Requested			
Total Expenditures	0	0	

Funding Sources

General Fund/WA GF			
State/Federal			
Fees/Other			
Use of Fund Balance			
Contingencies			
Total Sources	0	0	0

Narrative Explanation of Fiscal Impacts:

There are no fiscal impacts associated with these agreements as St. Vincent De Paul has agreed to cover all the costs related to the operation of the shelter.

Staffing Impacts

Position Title (Payroll Classification)	Monthly Salary Range (A – I Step)	Additions (Number)	Deletions (Number)

Narrative Explanation of Staffing Impacts (If Required):

None

Attachments:
1. License Agreement 2. Operator Agreement 3. St. Vincent De Paul-Sonoma Operational Plan
Related Items "On File" with the Clerk of the Board:



LICENSE NUMBER	97
----------------	----

LICENSE TO USE STATE MILITARY PROPERTY

BETWEEN

CALIFORNIA MILITARY DEPARTMENT

AND

The Sonoma County Community Development Commission

FOR

USE OF READINESS CENTER IMPROVEMENTS AND GROUNDS

This AGREEMENT, dated for reference the 26th of October, 2018, by and between the California Military Department (CMD), hereinafter called STATE, and the Sonoma County Community Development Commission, 1440 Guerneville Road, Santa Rosa, CA 95403, hereinafter called LICENSEE, without distinction as to number or gender, and effective upon execution by STATE. STATE and LICENSEE are sometimes referred to individually as a "party" or collectively as the "parties".

RECITALS

WHEREAS, the STATE has under its jurisdiction, certain real property known as the Santa Rosa armory, located at 1500 Armory Drive, Santa Rosa, CA 95401, hereinafter called PREMISES, identified in **Exhibit "B"**, consisting of one (1) page and attached hereto and incorporated herein by this reference.; and,

WHEREAS, it is essential that STATE have a secure facility and surrounding grounds; and,

WHEREAS, PREMISES may be made available to meet the needs of the local civil authority when not required to meet immediate operational requirements;

NOW THEREFORE, STATE and LICENSEE agree as follows:

WITNESSETH

I.

GENERAL PROVISIONS

1. AGREEMENT is for **non-exclusive weekday or weekend use** throughout the license term.
2. Upon declaration of emergency by the STATE or federal government, STATE reserves the right to reoccupy PREMISES, including all parking areas, with twenty-four (24) hours written or electronic (voice or email) notice to LICENSEE at the notification address/number below.
3. PREMISES will not be available during the following drill periods: November 15-

18, 2018; January 12-13, 2019; February 5-10, 2019; March 21-24, 2019.

4. LICENSEE shall comply with all applicable statutes, laws, ordinances and rules or regulations adopted by the Federal, State or any City, City and County, County or other body politic pertaining to use of said premises or any provisions of the License.
5. LICENSEE shall comply with such reasonable rules and regulations as may be prescribed by STATE for the reasonable use and occupation of State Facilities.
6. LICENSEE understands and agrees the California Legislature may impose additional restrictions, limitations or conditions affecting AGREEMENT provisions or terms; however, any such changes become effective no sooner than 30 days after the legislature has acted.
7. This agreement shall not be assigned or sublet or otherwise encumbered, in whole or in part, without STATE'S prior written consent.
8. STATE shall supply PREMISES with utilities.
9. LICENSEE shall have use of the Offices, Storage Areas, Drill Floor, Latrines, Showers, parking areas for placement of storage containers (IF REQUIRED), and Kitchen Counters (no use of the oven or stove top), but only for temporary food storage, providing all food will be removed and surfaces cleaned on a daily basis when shelter operations are underway.
10. STATE is not responsible for losses or damage to personal property, equipment or materials of LICENSEE, its employees or agents and all losses shall be reported to STATE immediately upon discovery.
11. LICENSEE shall not drive any nails, tacks, pins or other objects into the walls, ceilings, partitions, windows, woodwork, or other part of PREMISES nor change in any manner or move any fixture on PREMISES or make any alterations or changes to PREMISES without prior written consent of the STATE (J9).
12. Upon completion of use, LICENSEE shall remove all decorations, display, signs or equipment on PREMISES.
13. Upon expiration of this license, LICENSEE will surrender PREMISES to STATE with appurtenances and fixtures in good order, condition, and repair, reasonable use and wear thereof and Acts of God excepted.
14. LICENSEE shall not permit any alcoholic beverage to be offered for sale, stored, given away or otherwise disposed or consumed on any part of PREMISES, nor shall LICENSEE permit any use of tobacco products on any part of PREMISES or within twenty (20) feet of entrances, doorways or opening windows, and then only in a controlled area under LICENSEE supervision.
15. LICENSEE acknowledges PREMISES may not be fully ADA compliant and agrees to implement or improve, at its sole cost and expense, those necessary compliance measures required for the duration of its use. Furthermore, LICENSEE agrees to provide any and all required temporary emergency lighting required by State, County or City laws or ordinances.

II.

AUTHORIZED ACTIVITIES

1. LICENSEE agrees to clean PREMISES and remove all litter, trash, cans, bottles, etc. from the site after each period of use, but not less than once per day. LICENSEE shall also ensure provision of janitorial service for the restrooms, showers, and drill floor by a licensed contractor or qualified civil service employee. The armory will be cleaned and sanitized according to the standards set forth in **Exhibit "F"**, made a part hereof by this reference. A copy of the contract with the janitorial contractor, if that service will not be delivered by city/county employee, shall be provided to STATE before license shall commence.
2. LICENSEE, in order to provide a variety of health and medical services to homeless citizens, may provide on-site program management through either LICENSEE employees, agents or volunteers or through contracted services.
3. The armory facility will be available fourteen (14) hours each day unless otherwise approved by the STATE for extended periods during inclement weather conditions.
4. LICENSEE shall provide a minimum of one (1) appropriately licensed and easily identifiable uniformed security guard, with a current and valid security guard card, on the premises of the armory one hour before the shelter opens until one hour after lights-out in the evening. The security officer shall have access to a telephone, provided by LICENSEE, for contacting the appropriate law enforcement agency, should it become necessary. LICENSEE is responsible for protecting patrons, agents and invitees from acts of third parties, and agrees to notify STATE and appropriate law enforcement agencies as required.
5. Uniformed security personnel will check (search) each client for weapons and drug paraphernalia before any client may enter, or reenter the armory. On site supervising soldiers are not security personnel and WILL NOT assist with weapon checks or other security-related actions; however, they will observe the security inspections.
6. Security personnel will notify the military site supervisor or, if one is not available, the Area Coordinator or the Facilities and Infrastructure Department (J-9) or the STATE Program Manager before leaving the PREMISES. A copy of the security contract will be due to the STATE before the license term begins.
7. Consistent with GC 15301.3(e), LICENSEE shall provide STATE a schedule from local law enforcement with jurisdiction over the armory identifying the time its officers will conduct mandated periodic armory visits each night of shelter operation.
8. Any damage to PREMISES will be inspected by STATE representatives (CMD Area Coordinator) and LICENSEE to determine the character and extent of damage (with photographs). Repairs should be completed within twenty-four (24) hours if an emergency or seventy-two (72) hours if urgent.
9. The STATE Area Coordinator will contract for necessary repair or restoration services using appropriate state or federal guidance, while coordinating and collaborating closely with LICENSEE. LICENSEE may not undertake repairs or restoration using its own forces or contract services without the prior written

consent of STATE'S Area Coordinator.

10. Within thirty (30) days of being presented a demand (invoice) for payment, LICENSEE shall make STATE whole for the cost of repairing or restoring any improvement or utility damaged as a result of PREMISES shelter use. If significant plumbing issues occur due to continued clogging by the clients, the county, at its sole cost and expense, will provide portable latrines for the duration of the contract.
11. LICENSEE shall take all necessary steps to ensure shelter clients do not constitute a nuisance in the immediate vicinity of the armory during hours of shelter operation. If at any time the STATE is dissatisfied with the LICENSEE efforts, the LICENSEE and STATE shall meet to explore means and methods of compliance.
12. LICENSEE shall supply sanitary items and paper products to include, but not limited to: cleaning/sanitizing supplies and equipment, liquid soap, paper towel, and toilet paper. If requested (necessary), the County Health Department shall provide periodic health screenings and consultation on issues pertaining to sanitation
13. Pets of clients occupying PREMISES or participating in provided services are prohibited inside the PREMISES, with the exception of those meeting the definition of *service animal* in Section XV below.
14. LICENSEE shall conform to the guidance and recommendations for tuberculosis prevention outlined in "*Preventing Tuberculosis (TB) in Homeless Shelters: A Guide for Preventing and Controlling TB and other Aerosol Transmissible Diseases in Los Angeles County Facilities*", included as **Exhibit "C"** herein and by this reference made a part hereof.
15. LICENSEE shall ensure that shelter clients demonstrate valid vehicle registration and insurance to be allowed to park their vehicle in PREMISES parking area.
16. Vehicles parked on PREMISES without appropriate approval shall be towed away by STATE's order and at LICENSEE's risk and expense.

III.

NOTIFICATION

All notices or other communications required or permitted hereunder shall be in writing, and shall be personally delivered (including by means of professional messenger service) or sent by overnight courier, or sent by registered or certified mail, postage prepaid, return receipt requested to the addresses set forth below. All such notices or other communications shall be deemed received upon the earlier of (i) if personally delivered or sent by overnight courier, the date of delivery to the address of the person to receive such notice, (ii) if mailed as provided above, on the date of receipt or rejection, when received by the other party if received Monday through Friday between 6:00 a.m. and 5:00 p.m. Pacific Standard Time. so long as such day is not a State or Federal holiday and otherwise on the next day provided that if the next day is Saturday, Sunday, or a state or federal holiday, such notice shall be effective on the following business day.

To LICENSEE:

Sonoma County Community Development Commission
Attn: Homeless & Community Services Manager

1440 Guerneville Road
Santa Rosa, CA 95403
(707) 565-7548

To STATE:

California Military Department
9800 Goethe Road, Box 18
Sacramento, CA 95826
(916) 854-3788

PROGRAM MANAGER:
SSG Monica Estrada
(916) 854-3128

Notice of change of address or telephone number shall be given by written notice in the manner described in this section. LICENSEE is obligated to notice State offices listed above and the failure to provide notice to do so shall constitute a lack of notice. Nothing contained herein shall preclude the giving of any such notice by personal service.

IV. INSURANCE REQUIREMENTS

LICENSEE is a public entity, which is self-insured and will be responsible for any damage caused to PREMISES. Additionally, LICENSEE shall indemnify STATE against any injuries caused by use of PREMISES. LICENSEE has furnished the necessary Certificate of Self-Insurance, **Exhibit "D"** attached hereto and incorporated herein by this reference, demonstrating the required insurance coverage will be in effect during the complete term of AGREEMENT, and shall include, but not be limited to:

- Combined single limit liability of \$2,000,000, or
- Special event coverage with a limit of \$2,000,000, and
- A statement naming the United States, State of California, its officers, agents, employees, and servants as additional insured, but only with respect to the activities of the named insured.

V. HOLD HARMLESS INDEMNIFICATION

The PREMISES are provided in "AS-IS" and "WITH ALL FAULTS" condition, and STATE and its employees, representatives and agents disclaim all warranties, expressed or implied, regarding the PREMISES, including, but not limited to, all implied warranties of merchantability or fitness for a particular purpose or compliance with Applicable Law. LICENSEES acknowledges and agrees that STATE and its employees, representatives and agents have made no representations or warranties for the PREMISES, including, without limitation, any representations or warranties regarding, (a) the condition or repair of the PREMISES, (b) whether such PREMISES are sufficient for the purposes of LICENSEE, or (c) whether the PREMISES comply with Applicable Laws (as defined below), including without limitation the Americans with Disabilities Act (ADA) or other accessibility laws, (d) whether there are any facts or conditions affecting the PREMISES that might, individually or in the aggregate, interfere with the use or occupancy of the PREMISES or any portion thereof by LICENSEE.

The use of the PREMISES by LICENSEE shall be conclusive evidence that LICENSEE accepts the same "AS IS and WITH ALL FAULTS" and that the PREMISES are suited for

the use intended by LICENSEE and are in good and satisfactory condition at the time such possession was taken. LICENSEE represents and warrants to STATE that (a) its sole intended use of the PREMISES is for temporary sheltering (the "Permitted Use") and (b) prior to using the PREMISES it has made such investigations as it deems appropriate with respect to the suitability of the PREMISES for its intended use and has determined that the PREMISES are suitable for such intended use.

LICENSEE shall comply with all applicable statutes, laws, ordinances and rules and regulations adopted by the Federal, State or any City, City and County, County or other body politic, including without limitation all building codes, the ADA or other accessibility laws ("Applicable Laws") and which pertains to use of the PREMISES or any provisions of the License, and will indemnify, defend and hold STATE free and harmless from and against any violations thereof and any and all liabilities, suits, causes of action, judgments, demands and claims for damages, including all reasonable costs of any litigation and attorney's fees and expenses, arising out or by reason of any such violation.

LICENSEE shall indemnify, defend and hold STATE its employees, representatives and agents free and harmless from and against any and all suits, causes of action, demands, proceedings, claims, damages, judgments, obligations liabilities, liens, fines, costs, and expenses (including, but not limited to, attorneys' fees and costs) (collectively "Losses") which arise from or are related to (a) use or occupancy of the PREMISES by LICENSEE or its Representatives, including, but not limited to, damage to property of any kind whatsoever and to whomsoever belonging, including LICENSEE, from any cause or causes whatsoever during the term of this License or any occupancy hereunder, holdover periods or any other occupancy of the PREMISES during the term of this License, except (i) those Losses that are ultimately determined by a court or administrative tribunal of competent jurisdiction to be caused by sole gross negligence of the STATE or its employees, or (ii) to the extent any such Losses are ultimately determined by a court or administrative tribunal of competent jurisdiction to be caused by the willful misconduct of the STATE or its employees; provided, however, any condition of the PREMISES that is found to be in violation of any Applicable Law by a court or administrative tribunal of competent jurisdiction shall not be deemed gross negligence or willful misconduct on the part of the STATE or its employees; (b) breach of LICENSEE'S obligations under the AGREEMENT, (c) negligence or other wrongful act by LICENSEE or its Representatives, (d) violation of Applicable Law by LICENSEE or its Representatives, (e) any allegation that the PREMISES do not comply with Applicable Law. "Representatives" means LICENSEE'S agents, employees, representatives, contractors, or any other person or persons acting within the direct control or authority of such party or its agents, employees, representatives or contractors.

VI.

FEES

1. The use fee is Five Hundred Forty Dollars (**\$540**) for each use period as agreed in this license, which includes utility costs and payment for supervising service members (2 per day).
2. Each use period is fourteen (14) hours; typically, 5:30 PM to 7:30 AM.
3. The total number of use periods for which an armory was committed to program use will be tabulated monthly.
4. The number of use periods will be multiplied by \$540 to establish the total fee to be remitted to the STATE. Rental periods operate on an approved twenty-four

(24) hour cycle will be billed at a 24-hour rate of Eight Hundred Eighty Dollars **(\$880)**.

5. Extraordinary utility costs will be assessed LICENSEE on an as-incurred basis and included as a surcharge in invoices from STATE.
6. Payment for armory use is due and payable the first business day of each following month and is considered delinquent after the fifteenth (15th) of the month.
7. LICENSEE's check will display STATE'S License number as shown on Page 1 of this document and be made payable to the California Military Department. Payment will be remitted to the address in Section III - Notification, and LICENSEE shall not require receipt of an invoice before issuance of payment due.

VII. TERM

License shall take effect no earlier than November 19, 2018 or upon execution by STATE, whichever is later, and shall expire no later than 0800 (8:00 A.M.) March 3, 2019.

VIII. AMENDMENT AND TERMINATION

AGREEMENT cannot be amended or modified in any way except by a written AGREEMENT duly executed by STATE and LICENSEE. Any proposal for amendment or modification must be delivered for review and approval by the Chief, Realty Operations or her/his delegatee.

AGREEMENT may be terminated by either party upon 30 days written notification to the other party at the addresses previously given. Upon termination, the activities of the parties shall be governed by the applicable provisions of the Military and Veterans Code. STATE is not obligated to reimburse LICENSEE any fees should it terminate this AGREEMENT before reaching its full term.

IX. ENTIRE AGREEMENT

AGREEMENT, along with any exhibits attached hereto, constitutes the entire covenant and understanding between STATE and LICENSEE for PREMISES. AGREEMENT supersedes all prior and contemporaneous routine activity agreements, representations or understandings, if any, whether oral or written.

X. DURATION & RENEWAL

AGREEMENT shall remain in effect through the termination date and will not be extended, but may be renewed annually subsequent to renegotiation required to protect the parties.

XI. RIGHT TO ENTER

During continuance in force of AGREEMENT, there shall be, and is hereby expressly reserved to STATE and to any of its contractors, agents, employees, representatives, or licensees, the right at any and all reasonable times, and any and all places to temporarily enter upon said PREMISES for inspection or other lawful STATE purposes.

XII. ENVIRONMENTAL LAWS AND REGULATIONS

LICENSEE must comply with all applicable local, State or Federal environmental

provisions, requirements, ordinances, regulations or laws. AGREEMENT does not constitute any form of authorization, permit, or opinion with respect to the satisfaction thereof. LICENSEE agrees that it shall comply with all laws, federal, state, or local, existing during the term of this license pertaining to the use, storage, transportation, and disposal of any hazardous substance as that term is defined in such applicable law.

1. In the event STATE or any of its affiliates, successors, principals, employees, or agents should incur any liability, cost, or expense, including attorney's fees and costs, as a result of the LICENSEE'S illegal use, storage, transportation, or disposal of any hazardous substance, including any petroleum derivative, the LICENSEE shall indemnify, defend, and hold harmless any of these individuals against such liability.
2. Where the LICENSEE is found to be in breach of this Paragraph due to the issuance of a government order directing the LICENSEE to cease and desist any illegal action in connection with a hazardous substance, or to remediate a contaminated condition caused by the LICENSEE or any person acting under LICENSEE'S direct control and authority, LICENSEE shall be responsible for all costs and expenses of complying with such order, including any and all expenses imposed on or incurred by STATE in connection with or in response to such government order.

XIII.

DEFAULT

LICENSEE shall make all required payments to the STATE without deduction, default or delay. In the event of the failure of LICENSEE to do so, or in the event of a breach of any of the other terms, covenants or conditions herein contained on the part of LICENSEE to be kept and performed, and if such default continues for a period of thirty (30) days after receipt of written notice from STATE to LICENSEE of such default, this License may, at the STATE'S sole discretion, be terminated.

In the event of termination of this License, it shall be lawful for STATE to reenter into and upon the PREMISES and every part thereof and to remove and store at LICENSEE'S expense all property therefrom and to repossess and occupy the PREMISES. In the event STATE terminates this License pursuant to this Paragraph, the STATE shall not be required to pay LICENSEE any sum or sums whatsoever.

XIV.

SERVICE ANIMALS

Service Animal Defined by Title II and Title III of the ADA: (from the ADA National Network)

Under Title II and III of the ADA, service animals are **limited to dogs** individually trained to do work or perform tasks for the benefit of an individual with a disability, including a physical, sensory, psychiatric, intellectual, or other mental disability.

Emotional support animals, comfort animals, and therapy dogs are not service animals under Title II and Title III of the ADA. Other species of animals, whether wild or domestic, trained or untrained, are not considered service animals either. The work or tasks performed by a service animal must be directly related to the individual's disability. A doctor's letter does not turn an animal into a service animal.

Examples of animals fitting the ADA's definition of "service animal" because they have been **specifically trained to perform a task for the person with a disability:**

Guide Dog or Seeing Eye® Dog1 is a carefully trained dog that serves as a travel tool for persons who have severe visual impairments or are blind.

Hearing or Signal Dog is a dog that has been trained to alert a person who has a significant hearing loss or is deaf when a sound occurs, such as a knock on the door.

Psychiatric Service Dog is a dog that has been trained to perform tasks that assist individuals with disabilities to detect the onset of psychiatric episodes and lessen their effects.

SSigDOG (sensory signal dogs or social signal dog) is a dog trained to assist a person with autism. The dog alerts the handler to distracting repetitive movements common among those with autism, allowing the person to stop the movement (e.g., hand flapping).

Seizure Response Dog is a dog trained to assist a person with a seizure disorder. The dog may stand guard over the person during a seizure or the dog may go for help. A few dogs have learned to predict a seizure and warn the person in advance to sit down or move to a safe place.

While Emotional Support Animals or Comfort Animals are often used as part of a medical treatment plan as therapy animals, **they are not considered service animals under the ADA**. These support animals provide companionship, relieve loneliness, and sometimes help with depression, anxiety, and certain phobias, but do not have special training to perform tasks that assist people with disabilities and are not covered by federal laws protecting the use of service animals.

A public facility is not allowed to ask for documentation or proof a dog has been certified, trained, or licensed as a service animal. Staff on site may ask the following questions:

1. Is the dog a service animal required because of a disability?
2. What work or task has the dog been trained to perform?

No further questions should be asked regarding the disability or the animal, nor is it permissible to ask that the dog perform the task that grants it to be a service animal.

CONCURRENCE

INSTALLATION COMMANDER

DATE: 26 OCTOBER 2018

SONOMA COUNTY COMMUNITY DEVELOPMENT COMMISSION

DATE:

FOR THE ADJUTANT GENERAL

DATE: 26 OCTOBER 2018

Enclosures:

- 1 Exhibit A; Vicinity Map
- 2 Exhibit B; Location Map
- 3 Exhibit C; Preventing Tuberculosis
- 4 Exhibit D; Certificate of Self-Insurance
- 5 Exhibit E; Lead Survey
- 6 Exhibit F; Janitorial Services
- 7 Exhibit G; California Government Code 15301

EXHIBIT A

VICINITY MAP/REGION



EXHIBIT B

ARMORY LOCATION/PREMISES



EXHIBIT C

Preventing Tuberculosis (TB) in Homeless Shelters:

A Guide for Preventing and Controlling TB and other
Aerosol Transmissible Diseases in Los Angeles County Facilities

Second Edition
June 6, 2013



Recommendations to help homeless service providers prepare their facility, staff, and clients for possible cases of aerosol transmissible diseases, like tuberculosis.

Table of Contents

Letter from the Director and Health Officer	3
Responsibilities: The Department of Public Health	4
Preventing TB and other ATDs	4
Providing expert consultation and training.....	4
Gathering data through mandated reporting and ongoing surveillance.....	4
Responsibilities: 6 Steps Homeless Shelters Can Take to Reduce the Spread of ATDs	5
1. Appoint an ATD Administrator/TB Liaison.	6
2. Create an environment that limits the spread of ATDs in your facility.	7
3. Enforce screening and other requirements for staff and volunteers that have direct client contact.....	7
TB Screening and Medical Services for Employees.....	7
TB Screening for Volunteers	8
4. Enforce screening and referral requirements for clients.	8
Initial Screening at Intake and Annual Screening	8
Referral Process.....	9
Shelter TB Clearance	10
If Medical Evaluation found client to be free of active TB or other ATDs:.....	10
If Medical Evaluation found client has active TB disease or other ATDs:.....	10
Cough Alert Protocol	10
Section Summary: Linking Symptomatic Clients to Healthcare.....	11
5. Keep accurate, legible, and confidential records.	12
6. Establish clear communication pathways.	12
Appendices	
<u>Appendix A:</u> California Code of Regulations, Title 8, Section 5199 ATD Requirements for Homeless Shelters	13
<u>Appendix B:</u> Frequently Asked Questions about Tuberculosis (TB).....	15
<u>Appendix C:</u> TB/ATD Symptom Questionnaire	17
<u>Appendix D:</u> Referral for TB Screening or Clearance.....	18
<u>Appendix E:</u> Weekly Cough Alert Log	19
<u>Appendix F:</u> Department of Public Health, Public Health Centers.....	20
<u>Appendix G:</u> Department of Public Health, Other Tuberculosis-Related Resources.....	21
<u>Appendix H:</u> Department of Health Services, Urgent Care Centers.....	22
<u>Appendix I:</u> Department of Health Services, Public Hospitals	24
<u>Appendix J:</u> Other ATDs: Signs & Symptoms and What to do if Observed.....	25
<u>Appendix K:</u> References.....	26

Letter from the Director and Health Officer

Dear Public Health Partners,

The Los Angeles County Department of Public Health (DPH) is pleased to issue these recommendations. They're meant to help homeless service providers, like you, to prepare their facility, staff, and clients for possible cases of Aerosol Transmissible Diseases, also known as ATDs.

ATDs are infectious diseases that can spread through coughing and sneezing. They spread from person-to-person either through the air, like tuberculosis (TB) and measles, or through droplets, like influenza (flu) or meningitis.

As a homeless service provider, you work closely with clients to help meet their needs. This vital function makes you a key partner in the fight to prevent the spread of TB and other ATDs in LA County homeless shelters.



TB prevention and control among homeless persons may be challenging. But together, we can reduce and even eliminate the spread of TB and other ATDs. These guidelines aim to make this work easier and more efficient. They include tools and procedures that help...

- Increase awareness of TB and other ATDs among medical providers, staff, and clients.
- Establish procedures to assure clients showing signs of TB or other ATDs are assessed and referred to a healthcare provider in a timely manner and are not turned away for infectious disease-related concerns.
- Encourage ongoing, confidential, and free screening to help identify and treat TB and other ATD infections among staff and clients, in their earliest stage.
- Promote immunizations to decrease the risk of outbreaks of vaccine-preventable ATDs, such as pertussis and influenza.
- Increase communication between shelter and DPH staff for things like disease reporting, receiving the latest TB and other ATD trends, and coordinating annual educational updates.

You are key partners in protecting the health and well-being of some of LA County's most vulnerable residents and communities. We thank you for your continued support and sincerely hope this manual proves useful in your disease control and prevention efforts.

A handwritten signature in black ink that reads "Jonathan E. Fielding". The signature is written in a cursive, flowing style.

Jonathan E. Fielding
Director and Health Officer

Responsibilities: The Department of Public Health

The ATD regulation (8 CCR 5199, Aerosol Transmissible Diseases) is a standard put in place by the California Occupational Safety and Health Administration (Cal/OSHA). It is meant to protect workers at facilities and in occupations that have a higher risk of ATD exposure, such as healthcare settings, correctional facilities, drug treatment programs, and homeless shelters. [See Appendix A](#) for a brief Cal/OSHA summary for Homeless Shelters of the ATD regulation.

The Tuberculosis Control Program and Community Health Services Division are two components of the LA County Department of Public Health. They both use the ATD regulations to help homeless shelters and other facilities prevent and control TB/ATDs in their facilities and operations. They also work together to provide the following TB/ATD prevention and control activities:

Preventing TB and other ATDs

- Investigate, follow-up, and treat all reported cases and suspected cases of TB and their “contacts.” “Contacts” refers to people who have been exposed to a person with a communicable disease, including TB.
- Operate several public health centers throughout LA County to provide TB medications, diagnostic follow-up, periodic clinical evaluations, contact investigation, and case management services ([See Appendix F](#)).
- Provide short-term, single-room occupancy housing and meal assistance to facilitate treatment completion, as needed.

Providing expert consultation and training

Each homeless shelter in LA County has an assigned District Public Health Nurse Liaison (DPHN). DPHN’s have several responsibilities, including:

- Serve as the DPH liaison to homeless shelters in LA County
- Meet with shelter staff to discuss TB/ATD prevention protocols
- Help shelter staff understand their role in cough alert screening through “role modeling” activities
- Facilitate appropriate and timely public or private health care provider assessments for symptomatic shelter clients
- Assist clients to obtain appropriate TB clearance, if necessary
- Coordinate and conduct contact investigations in shelters
- Facilitate TB/ATD education for shelter staff, volunteers and clients
- Answer shelter staff’s TB-related questions

Gathering data through mandated reporting and ongoing surveillance

- Work with doctors, hospitals, labs, and other important community partners, including homeless shelters, that can help identify possible cases at their earliest stages
- Work with community organizations, like homeless shelters, to help their staff recognize symptomatic clients who might need medical evaluation
- Monitor and report disease-related data to local, state, and federal agencies

[See Appendix F](#) for a list of DPH health centers and appropriate phone numbers.

Responsibilities: LA County Homeless Shelters

Reading Cal/OSHA’s ATD regulation is the best way to make sure your facility is compliant with all of its components. [See Appendix A](#) for links to the ATD regulation that list all related diseases, settings, roles, and expectations.

Homeless shelters in LA County should implement TB and ATD infection prevention guidelines to accomplish the following goals:

- Protect clients, staff, and volunteers from TB and other ATD exposures
- Detect active TB disease among clients at an early stage
- Decrease the chance that homeless persons will be turned away from shelters because of infectious disease-related concerns
- Ensure referral to a health care provider for medical screening and care

Taking the following steps will help meet these goals and help you implement the main components of the ATD regulation, particularly as they relate to TB.

6 Steps to Reduce the Spread of ATDs in Your Facility

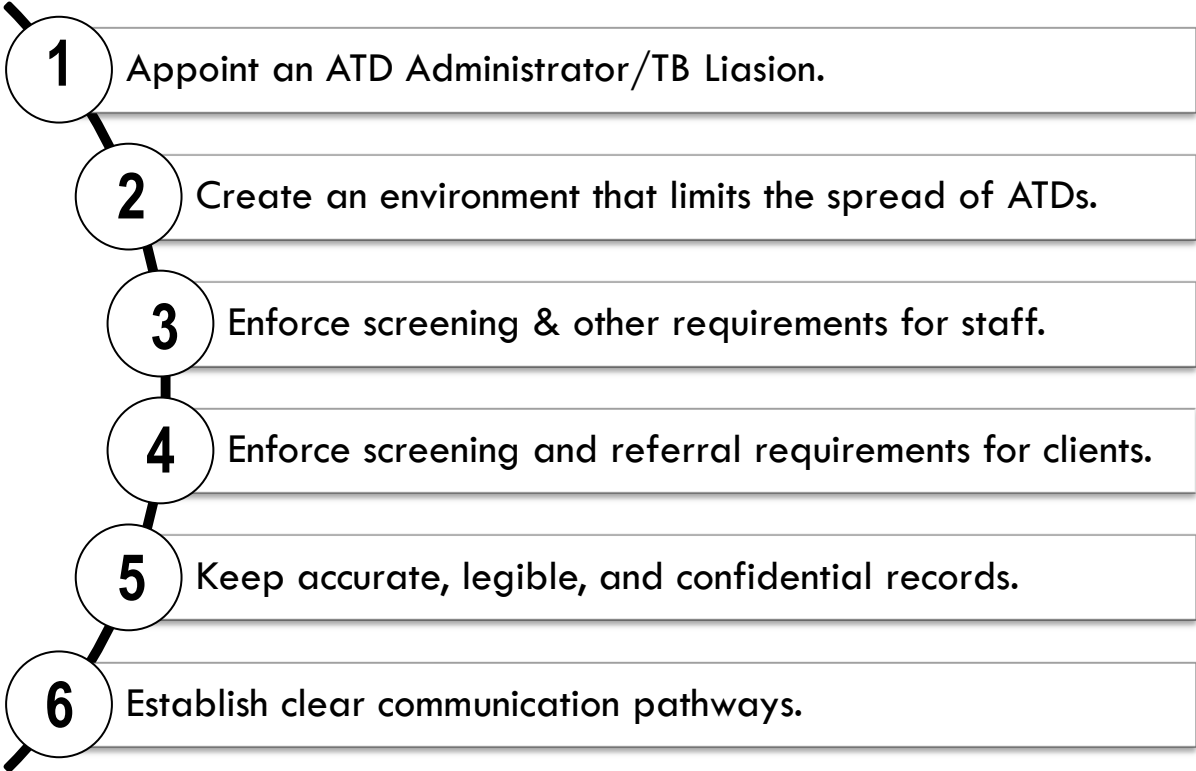

1. Appoint an ATD Administrator/TB Liaison.

Under the Cal/OSHA ATD standard, homeless shelters must appoint an administrator to oversee activities that control the spread of TB and other ATDs. This person doesn't need to be a clinician or manager/supervisor/facility administrator. However, they should have some knowledge of infection control principles.

The ATD Administrator performs and oversees several activities that prevent the spread of TB and other ATDs, including:

Key Area	Activities
Administrative— Shelter duties	<ul style="list-style-type: none"> • Serves as or delegates a “TB Liaison” • Ensures confidential at-hire and annual medical screening of staff and volunteers that have direct client contact • Coordinates referrals for clients that need a TB evaluation • Assists clients that need a TB evaluation with their transportation needs • Maintains medical confidentiality policies and procedures
Administrative— DPH liaison duties	<ul style="list-style-type: none"> • Serves as a liaison to the Department of Public Health (DPH) • Coordinates screening activities and referrals with DPH (See Appendix F for a list of DPH health centers and appropriate phone numbers) • Assists DPH to conduct infectious disease contact investigations • Coordinates communication with the DPH local health officer • Maintains confidential records
Compliance	<ul style="list-style-type: none"> • Establishes, implements, maintains, and posts written procedures • Ensures staff adheres to TB/ATD prevention procedures • Ensures staff adheres to TB/ATD Cough Alert and documentation procedures • Ensures staff and clients receive mandatory TB/ATD prevention education (See Appendix G for TB Control Program health education services) • Ensures that identified medical providers maintain confidential medical records • Maintains other required records

2. Create an environment that limits the spread of ATDs in your facility.

Remember, reading the standard is the best way to make sure your facility is doing all it can to prevent the spread of TB and other ATDs. But taking the following steps will help limit the spread of TB in your facility:

- Ensure mechanical ventilation systems are working properly and are maintained regularly
- Keep records of all inspections, maintenance, and repairs done on the facility's mechanical ventilation systems
- Consult an environmental engineer to find out if using ultraviolet lighting, which kills TB bacteria, is right for your facility
- Open doors and windows to promote air exchange, especially in areas where clients congregate
- Make sure each bed is numbered to help DPH track potentially infectious clients
- Maintain as much space as possible between beds in sleeping areas
- Position beds in a "head to toe" pattern rather than "head to head" pattern
- Make hand sanitizer, tissues, and trash cans readily available
- Post TB-related posters and pamphlets ([See Appendix G](#) for TB Control Program health education services)

3. Enforce screening and other requirements for staff and volunteers that have direct client contact.

Volunteers and staff that work directly with clients have a higher chance of coming into contact with people that may be sick with an ATD. Putting the following measures in place will help keep shelter staff and volunteers healthy:

TB Screening and Medical Services for Employees

Shelters must require staff to get a TB evaluation when they first start working and then again once a year as long as they continue their service. Shelters should make these annual medical exams available, without cost, to employees who have a greater risk of coming into contact with ATDs while on the job. Shelters must also provide access to free vaccine(s) and respiratory protection for identified job risks. Shelters should also generally advise staff to stay home if they have prolonged coughing. If they don't improve, advise them to see a physician. Staff sent off work because of their coughing must get clearance to return to work from a licensed healthcare provider. Under state and federal law, employees' TB screening and other medical results/records are confidential and should not be disclosed by the medical provider to employer management personnel or to anyone in the workplace.

For initial evaluation persons who have a prior positive TB test should get a chest x-ray or have written copy of a radiologist's report of a chest x-ray that was performed within the past six months. Medical providers must ensure that all persons with a new positive TB skin or blood test must also have a chest x-ray,

Remember, reading the Cal/OSHA ATD standard is the best way to make sure your facility is doing all it can to prevent the spread of TB and other ATDs among its employees.

TB Screening for Volunteers

DPH recommends that shelters require volunteers to get a TB evaluation from their private medical provider or community-based clinic when they first start volunteering and then again once a year as long as they continue their service. [See Appendix F](#) for a list of DPH clinics that offer TB testing. Shelters should keep records that show volunteers completed the screening but should not receive copies of actual medical records or diagnoses. Shelters should take care to respect volunteers' medical privacy rights.

For initial evaluation, persons who have a prior positive TB test should get a chest x-ray or have written copy of a radiologist's report of a chest x-ray that was performed within the past six months. Medical providers must ensure that all persons with a new positive TB skin or blood test must also have a chest x-ray,

Remember, reading the standard is the best way to make sure your facility is doing all it can to prevent the spread of TB and other ATDs among its volunteers.

4. Enforce screening and referral requirements for clients.

Initial Screening at Intake and Annual Screening

- 1) Require written proof of TB screening clearance from a medical provider, dated within the past 12 months. Allow clients 7 days after intake or annual review to provide proof of TB clearance.
- 2) If clients don't have proof of medical clearance, arrange onsite screening and documentation. If onsite screening isn't available, refer clients for outside screening ([See Appendix D](#) "Referral for TB Screening or Clearance" form).
- 3) Track all TB screening clearances, whether done internally or by referral to an outside source. On each new entry to the shelter, staff should ask and observe: DOES THE CLIENT HAVE A COUGH?
 - a. If NO, shelter will advise client to notify shelter staff if a cough develops in the future.
 - b. If YES, shelter staff will refer the client to a private area to complete a symptom screen questionnaire.

- 4) If client has a cough for more than 3 weeks and 1 or more other symptoms of active TB disease, isolate client until referred for medical evaluation. Move client to a well-ventilated area or, if weather permits, an outside area. If the client is unable to get medical services right away, separate them from the other clients.
- 5) Give the client tissues right away and advise them to cover their nose and mouth when coughing or sneezing. Give the client a surgical mask and tell them to place it over their mouth and nose.
- 6) Promptly **refer** all symptomatic clients and clients who lack valid medical clearance to an appropriate health care provider for TB/ATD medical evaluation ([See Appendix D](#) “Referral for TB Screening or Clearance” form).

NOTE REGARDING CONFIDENTIALITY:

Results of medical evaluations for clients are considered protected health information and medical providers must keep them confidential.

Referral Process

Refer symptomatic clients and clients who lack valid medical clearance to the shelter’s onsite or other designated clinic. If none, refer clients as follows:

- 1) Weekday business hours (before 5pm) contact a DPH CHS Public Health Center ([See Appendix F](#)).
- 2) Evenings and weekends contact a Department of Health Services Urgent Care Center ([See Appendix H](#)) or public hospital emergency room ([See Appendix I](#)) where clients can get a medical evaluation on the same or next working day.
- 3) Call the receiving location and arrange to fax or hand deliver the completed forms ([See Appendix C](#) “Symptom Questionnaire” form) and ([See Appendix D](#), “Referral for TB Screening and Clearance” form)
- 4) Give the client a copy of both forms (Appendix C and Appendix D) in an envelope sealed for confidentiality.
- 5) The shelter will need to transport the client to the medical facility for the client’s medical evaluation and be prepared to return the client to the shelter, as needed.
- 6) Follow-up to ensure that the receiving clinic/urgent care center/hospital ER received the forms and that the client followed through with the medical evaluation.
- 7) Keep electronic or written log of clients referred for TB medical evaluation and status of client TB clearance.

Shelter TB Clearance

If Medical Evaluation found client to be free of active TB or other ATDs:

After a symptomatic client is referred to a medical provider and active TB/ATD disease is ruled out, the medical provider will give the client signed written clearance to return to a group living situation, like a homeless shelter. This medical clearance should expire one year from the date of the medical provider's signed clearance. (If recent community cases of active TB disease are identified, the Department of Public Health may require more frequent screening).

If Medical Evaluation found client has active TB disease or other ATDs:

Clients with active TB disease or other ATDs can return to the shelter when they show written proof from a licensed health care provider that they are no longer contagious.

Cough Alert Protocol

All shelter staff play an important role in preventing and controlling the spread of TB and other ATDs in their facilities. The list below describes activities staff will carry out to prevent and control TB:

All shelter staff will:

- Observe clients for persistent coughing and signs of active TB disease
- Refer anyone with a cough to a private area to complete the Review of TB/ATD Symptoms form ([See Appendix C](#) "Symptom Questionnaire" form)

Shelter staff (as directed by the TB Liaison /ATD Administrator) will:

- Complete a Weekly Cough Alert Log ([See Appendix E](#) "Weekly Cough Alert Log")
- Give a copy of the log to the ATD Administrator/TB Liaison right away during the day or the next morning if a coughing client is identified during the night

The TB Liaison/ ATD Administrator (or designee) will:

- Receive the Cough Alert Log
- Review the Cough Alert Log to identify any symptomatic client
- Follow Referral Process to refer symptomatic clients for medical evaluation and clearance.
- Isolate symptomatic clients (see Screening Steps 4, 5, 6 on page 9)
- Prominently display educational posters on Covering Your Cough ([See Appendix G](#) for TB health education services)
- Prominently display educational posters on tissue technique and disposal

Section Summary: Linking Symptomatic Clients to Healthcare

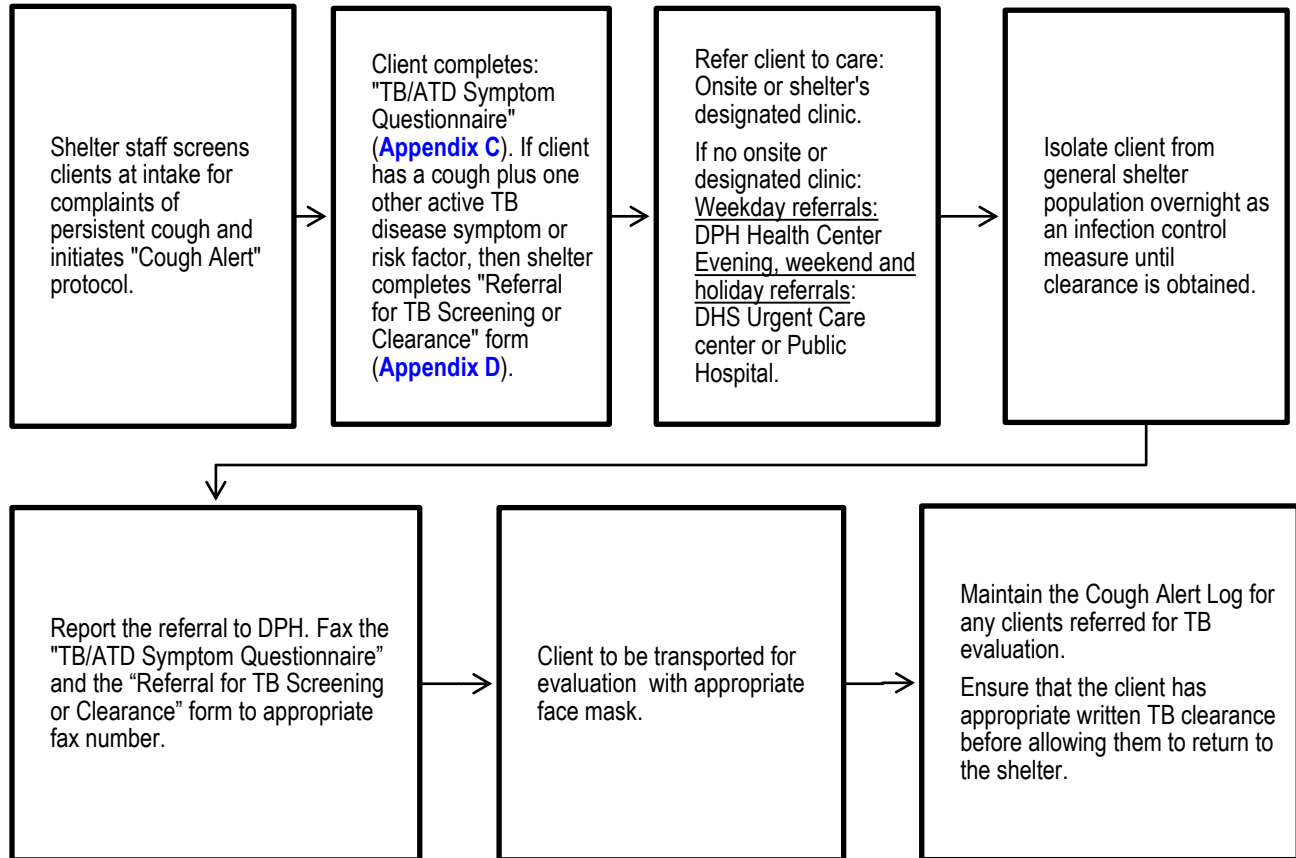

5. Keep accurate, legible, and confidential records.

Following steps in this guide will help protect your shelter from TB and other ATDs. You can also prevent having to pay fines by keeping detailed records of all transports, exposure incidents, trainings, and medical services for staff. The table below lists the main types of records you'll need to keep.

Type of Information	Minimum Information Required
Medical clearances	<ul style="list-style-type: none"> • Employee name and ID number No actual medical records should be accepted or received. Maintain medical providers' medical clearance reports related to: <ul style="list-style-type: none"> ○ Vaccination status ○ Vaccination declination forms ○ TB assessment results (initial and annual screening) ○ Doctors' assessments after exposure incidents
Training records	<ul style="list-style-type: none"> • Date(s) of annual training • Training curriculum and proof that it was developed in consultation with DPH • Names and qualifications of persons conducting training, • Names and qualifications of persons designated to respond to questions • Names and job titles of all training participants
Exposure Incidents	<ul style="list-style-type: none"> • Dated census logs, including bed locations and numbers, for at least six (6) months • Log of clients referred for TB medical evaluation and status of client TB clearance • Date of incident • Names, employee IDs, included in exposure • Disease or pathogen to which employees may have been exposed • Name and job title of person performing evaluation • Identity of any local health officers and physicians consulted • Date of evaluation • Date of contact communication and contact info for any other employers involved
Equipment	<ul style="list-style-type: none"> • Inspection reports of any ventilation systems or other engineering controls • Respiratory protection program audits
Documents	<ul style="list-style-type: none"> • Shelter employer's Cal/OSHA written Injury and Illness Prevention Program, including ATD infection control plan and Respiratory Protection program, as applicable

6. Establish clear communication pathways.

To prepare for possible ATD emergencies, establish clear communication pathways with collaborating employers, identified medical providers, and the local health department before an ATD exposure incident occurs.

Appendix A

California Code of Regulations, Title 8, Section 5199 ATD Requirements for Homeless Shelters

The Division of Occupational Safety and Health (DOSH) has prepared this summary sheet to assist employers and employees in understanding how Section 5199 applies in certain operations. This sheet is not intended to modify or replace the actual language of the standard, and employers should consult the actual language of the standard in preparing their programs.

Aerosol Transmissible Diseases – Homeless Shelters and Drug Treatment Programs

Employees in homeless shelters and drug treatment programs may be exposed to aerosol transmissible diseases (ATDs) because the populations receiving these services are at greater risk of having tuberculosis and some other ATDs. These workplaces may also be at increased risk of transmission due to a lack of adequate ventilation or crowded housing or treatment facilities. Most of these workplaces do not have trained health care providers on-site to determine whether people who are exhibiting ATD symptoms such as persistent coughing pose an infection risk. [Section 5199, Aerosol Transmissible Diseases](#), requires homeless shelters, drug treatment programs, and other work operations that come within the scope of the standard but that do not have health care providers, to establish some basic procedures for reducing the infection risk to their employees, including identification of clients who need further medical evaluation. These employers are required to:

1. Develop criteria that will be used to identify clients who should be referred to a health care provider. A suggested list of minimum criteria is included in Appendix F (*of the ATD standard*) [5199(c)(3)(B)].
2. Establish written procedures that will be used to refer the client to a health care provider (such as on-site health care services, mobile health care vans, public health agencies, or primary care providers) and to receive information back from the health care provider to determine if employees were exposed to an infectious disease and need follow-up care. (Generally referral is required within 5 hours, but an exception is provided for initial encounters that occur after 3:30 p.m.) [5199(c)(3)]
3. Establish written source control procedures for persons who enter the facility who are coughing or otherwise appear to have an ATD. These include providing the person with a surgical mask, or tissues and hand hygiene materials [5199(c)(2)].
4. While a person is in the facility awaiting referral, use source control and other measures to reduce employee exposure to droplets that may be coughed out or exhaled. These measures include, as available, placing the person in a separate room or area, preferably with a separate or filtered ventilation system. If the person is not using source control measures, the employer must provide a respirator to employees who must enter the area, if respirator use is feasible [5199(c)(5)]. Where respirators are used, the employer must have a respiratory protection program that meets the requirements of Section 5144, and subsection 5199(g) that includes employee medical evaluation, fit-testing and training.

5. Establish written communication procedures to inform employees, and other employers whose employees will have contact with the person, of the person's infectious disease status. This would apply to people who transport the client, as well as to the hospital or other facility that will receive him or her. The employer must also establish procedures to receive information from health care providers if the provider determines that a referred patient has a reportable¹ ATD [5199(c)(4)].
6. Establish procedures to provide the seasonal flu vaccine and annual TB tests to employees covered by this regulation [5199(c)(6)].
7. Establish written procedures for employees who have been exposed at work to a confirmed case of a reportable ATD. These include medical follow-up and continuation of pay for a period during which an employee is not sick but a physician or other licensed health care professional (PLHCP) recommends removal from the workplace because the employee may be contagious (unless alternate work is available) [5199(c)(6)].
8. Provide training at or prior to an employee's initial assignment to a job covered by this regulation, and at least annually thereafter [5199(c)(7)].
9. Annually review infection control procedures with employees in their work areas, and correct any problems found [5199(c)(8)].
10. Keep vaccination records, exposure incident records, records of inspection of any ventilation systems or other engineering controls, and if applicable, records for the respiratory protection program [5199(j)].
11. Maintain employee (and patient) confidentiality in regards to medical records, including records of vaccinations, TB assessments, and post-exposure medical services [5199(h), 5199(j), 3204(a)].

¹ Title 17, California Code of Regulations, Section 2500 lists diseases that are reportable to the local health officer.

Tuberculosis

1. What is Tuberculosis (TB)?

TB is caused by germs called bacteria. TB usually affects the lungs. It can be cured with prescription medicine given by a doctor.

You'll hear these two TB terms most often: **Latent TB infection** and **Active TB disease**. Latent TB infection means you have "sleeping" (inactive) TB germs in your body and can't infect anyone. These germs can live in your body without making you sick. Latent TB infection can later become active TB disease if these germs "wake up" (become active) and multiply. If you have active TB disease, you can infect other people.

2. How does TB spread?

TB spreads through the air from one person to another. TB germs spread when a person with active TB disease coughs, sneezes, speaks, sings or laughs. Anyone near the sick person can breathe in (inhale) the TB germs. You can't catch TB from clothes, dishes, food or body contact with someone who has TB. Transmission of TB is usually associated with prolonged or frequent close contact with a person with active TB disease.

3. What are the symptoms of active TB disease?

- Coughing for more than 2-3 weeks
- Weakness
- Chest pain
- Chills
- Coughing up blood or mucus

4. How do you test for TB?

A TB skin test or a blood test is used to find out if a person has latent TB infection. For the skin test, a small amount of liquid (tuberculin solution) is injected under the skin on the forearm. Then, 2-3 days later, a health care provider checks to see if there is a reaction to the liquid. It may take 8-12 weeks after coming into contact with the germ for your body to show a reaction to the TB skin test. Other tests show if you have TB disease.

5. What does it mean to have a "positive" test?

A positive TB test shows that the TB germ is present in the person's body but doesn't identify active TB disease. Only about 1 out of every 10 people with latent TB infection will develop active TB disease during their lifetime. If it's positive, other tests, like a chest x-ray, will be done to see if it's latent TB infection or active TB disease. Additional tests will be given to people who test positive on the TB tests. Depending on results, you may be asked to get a re-test in a few months, or you may be given treatment.

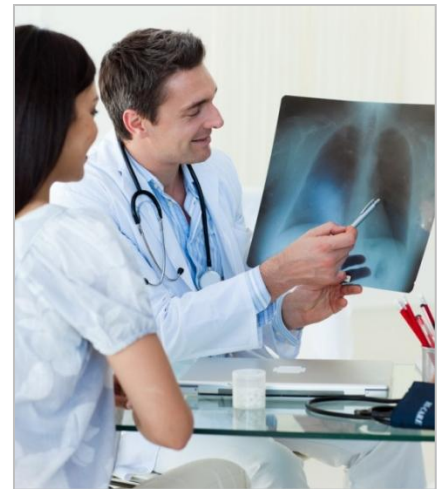

Tuberculosis (TB) Terms:

Latent TB Infection

A condition when TB germs are in the body but aren't active. People with latent TB infection have no symptoms, don't feel sick, and can't spread TB to others.

Active TB Disease

An illness caused when TB bacteria attack a part of the body, usually the lungs. A person with active TB disease can spread TB germs to others.

For More Information

Tuberculosis Control Program

<http://publichealth.lacounty.gov/tb/index.htm>
(213) 745-0800

6/6/2013

6. How is active TB disease treated?

TB disease can be treated with different anti-TB medicines. It takes at least 6 months to 1 year to kill TB disease in your body. It's very important to take all anti-TB medicine according to schedule. If you don't take the medicines correctly, the germs can become harder to get rid of. If you stop taking the medicines too soon, you can get sick again.

7. Can latent TB infection be treated?

Yes. Your health care provider can help you find the medicine that's best for you. If you have TB infection, you can take medicine to help prevent getting TB disease later. Depending on the type of treatment, it will take about 3-9 months to kill the TB germs in your body.

8. Should someone with active TB disease be restricted from school or work?

People with active TB disease can spread TB germs to family and friends. If you have active TB disease, you may have to stay away from other people until you can't spread TB germs. Taking your medicines correctly will shorten the time you need to be separated from others.

People with latent TB infection aren't contagious and can't spread TB to others. As a result, going to school and work is safe.

9. What is the role of the LA County Department of Public Health in controlling the spread of TB?

The LA County Department of Public Health works with your doctors to assure they have current TB screening, testing, and treatment procedures. When a person with active TB disease is reported to Public Health, our staff conducts an evaluation that includes identifying and screening individuals that may have been exposed to active TB disease.



10. How can TB be prevented?

If you DO NOT have active TB disease

- Avoid spending long periods of time in tight spaces with people who have active TB disease or who have just started treatment.
- Ask your health care worker for a TB test if you've spent a lot of time with someone who had TB disease. If you have a negative reaction to the TB test, have it repeated after 2-3 months.

If you DO have active TB disease

- Take all your medicines correctly.
- Always cover your mouth when you cough and/or sneeze.

Appendix C

TB/ATD Symptom Questionnaire

Instructions for Shelter Staff:

The purpose of this form is to help identify clients who **may** have infectious TB. Please complete this form as part of the initial intake process if (1) a client reports they have a persistent cough, (2) if shelter staff sees that the client is coughing or (3) if during annual review, shelter staff notes a client has a cough that has lasted for more than 3 weeks.

HISTORY/SYMPTOMS	Yes	No
Do you have a cough that has lasted for 3 weeks or more?		
1. Have you lost weight without explanation during the past month?		
2. Have you sweated so much during the night that you've soaked your sheets or clothing, during the past month?		
3. Have you coughed up blood in the past month?		
4. Have you been more tired than usual over the past month?		
5. Have you had fevers almost daily for more than one week?		

Does the client have a cough that has lasted 3 weeks or more **AND** has answered "yes" to at least one other question above? Yes No

If you marked "YES" above, immediately refer the client to services as follows:

During weekdays: [See Appendix F](#) for the nearest DPH Public Health Center

During weekends, evenings, or holidays: [See Appendices H & I](#) for the nearest DHS Urgent Care Center or Public Hospital

Exposure Control Methods Initiated:

- Give the client a surgical face mask to wear: Done
- Instruct the client to cover their nose and mouth when coughing or sneezing: Done
- Separate the client from others and place in a well-ventilated room: Done
- Initiate medical evaluation protocols and transportation: Done

Comments _____

Client Name: _____ Arrival Date: _____

Shelter Name: _____ Shelter Phone #: _____

Shelter Address: _____

Bed Location: _____

Evaluator Name: _____

Evaluator Signature: _____ Date: _____

Appendix D

Referral for TB Screening or Clearance

Instructions for Shelter Staff: Please fill out top part and put this form and completed **Appendix C** form in an envelope to assure client confidentiality. Ask the client to take the envelope to the clinic/hospital listed in this referral.

Name of referring shelter: _____

Name shelter contact person: _____ Telephone #: _____

Client's name: _____ Client Date of Birth (MM/DD/YY): _____

Bed location: _____

Date of arrival at shelter: _____ Referral date: _____

Name of clinic/hospital to which client was referred: _____

- Referral for Screening for shelter entrance (complete in 7 days)
- Referral for Clearance due to symptoms (Immediate)

Dear Provider,

This client was referred for a TB screening or evaluation, a requirement of all persons staying at this facility.

If referral is for general TB clearance, the form must be completed within 7 days.
If referral is based on symptoms currently present, please evaluate immediately.

To be completed by clinic/hospital physician or nurse (give a copy to client):

- Cleared for stay in congregate setting Date of clearance*: _____
- Not cleared; pending additional testing/ client needs medical follow up

Clinician Name: _____

Clinic/hospital Name: _____

** Tests should include the tuberculin skin test (TST) or TB blood tests (QuantiFERON or T-SPOT) and/or may also require chest x-ray.
If Provider has medical questions, please see L.A. County TB Control Program website at <http://publichealth.lacounty.gov/tb/healthpro.htm> or call (213) 745-0800.*

Appendix E

Weekly Cough Alert Log

Instructions for Shelter Staff:

Please give this log to your ATD Administrator/TB Liaison if you have a client that has a constant cough. The ATD Administrator/TB Liaison is responsible for (1) assessing the client for signs of active ATD/TB disease and (2) determining if the client needs a referral for a medical evaluation.

Name of Shelter: _____ Date (MM/DD/YY): _____

Date TB Liaison received copy of Log (MM/DD/YY): _____

Client Name (Last, First)	Date of Birth (MM/DD/YY)	Bed Location (Bed #)	Date(s) Client Observed to be Coughing (MM/DD/YY)	Name of Staff Member(s) who Observed Client Coughing (Last, First)	Referred to which Medical Facility	Transportation Arrangements Made (e.g. ambulance, taxi, other)	Comments
1.							
2.							
3.							
4.							
5.							
6.							
7.							
8.							

Appendix F

Los Angeles County Department of Public Health, Community Health Services Division PUBLIC HEALTH CENTERS

Antelope Valley Public Health Center 335-B East Ave., K-6, Lancaster, CA 93535	(661) 723-4648
Central Public Health Center 241 Figueroa St., Los Angeles, CA 90012	(213) 240-8251
Curtis-Tucker Public Health Center 123 West Manchester Blvd., Inglewood, CA 90301	(310) 419-5333
Glendale Public Health Center 501 N. Glendale Ave., Glendale, CA 91206	(818) 500-5760
Hollywood/Wilshire Public Health Center 5205 Melrose Ave., Los Angeles, CA 90038	(323) 769-7920
Martin Luther King Jr. Center for Public Health 11833 South Wilmington Ave., Los Angeles, CA 90059	(323) 568-8100 (Select "Speak to a nurse") (323) 568-8756 (323) 568-8757
Monrovia Public Health Center 330 West Maple Ave., Monrovia, CA 91016	(626) 301-1932
Pomona Public Health Center 750 S. Park Ave., Pomona, CA 91766	(909) 868- 0241
Torrance Public Health Center 711 Del Amo Blvd., Torrance, CA 90502	(310) 419-5333
Whittier Public Health Center 7643 S. Painter Ave., Whittier, CA 90602	(562) 464-5417

Appendix G

Los Angeles County Department of Public Health OTHER TUBERCULOSIS-RELATED RESOURCES

24-hour Communicable Disease Emergency Line

(888) 397-3993

Services:

- Help you report emergencies related to any disease that spreads from person-to-person

Hours:

Everyday 24 hours a day

Tuberculosis Control Program

2615 S. Grand Ave, Room 507, Los Angeles, CA 90007

<http://www.publichealth.lacounty.gov/tb/>

(213) 745-0800

(Select Option 4 "Health Ed")

Services:

- Answer your questions related to TB screening
- Help you find where to refer clients that have active TB disease symptoms
- Help you get TB-related technical assistance
- Help you get TB-related training videos/DVDs, posters, or presentations
<http://www.publichealth.lacounty.gov/tb/public.htm>
- Help you request a presentation: <http://tinyurl.com/LACSpeakersBureauRequestForm>

Hours:

Monday-Friday 8:00 am to 5:00 pm

Appendix H

Los Angeles County Department of Health Services, URGENT CARE CENTERS

El Monte Comprehensive Health Center

10953 Ramona Blvd., El Monte, CA 91731

(626) 579-8302: Main
(800) 383-4600: Appointments

Hours:

Monday – Friday 8:00 a.m. - 5:00 p.m.
Saturday (Walk-in) 9:00 a.m. - 5:00 p.m.

H. Claude Hudson Comprehensive Health Center

2829 S. Grand Ave., Los Angeles, CA 90007

(800) 341-9211: Main
(800) 383-4600: Appointments
(213) 744-3701: Urgent Care

Hours:

Monday – Friday 8:00 a.m. - 8:30 p.m.
Everyday (Urgent Care) 8:00 a.m. - 12 Midnight

Harbor/ University of California at Los Angeles (UCLA) Medical Center

1000 W. Carson St., Torrance, CA 90502

(310) 222-2356: Main
(310) 228-8110: Urgent Care

Hours:

Monday – Friday (Urgent Care) 8:00 a.m. - 11:00 p.m.
Saturday – Sunday (ER triage referral only) 10:00 a.m. - 5:00 p.m.
Everyday (Emergency Services) 24 hours a day

High Desert Multi-Service Ambulatory Care Center (MACC)

44900 N. 60th St. West, Lancaster, CA 93536

(661) 948-8581: Main
(661) 945-8520: Urgent Care

Hours:

Monday – Friday 8:00 a.m. - 4:30 p.m.
Everyday (Urgent Care) 8:00 a.m. - 12 Midnight

Hubert H. Humphrey Comprehensive Health Center

5850 S. Main St., Los Angeles, CA 90003

(323) 846-4312: Main
(323) 848-4269: Urgent Care

Hours:

Monday – Friday 8:00 a.m. - 5:00 p.m.
Everyday (Urgent Care) 8:00 a.m. - 12 Midnight

[More >](#)

Los Angeles County (LAC) + University of Southern California (USC) Medical Center

1220 N. State St., Los Angeles, CA 90033

(323) 409-2345: Main
(323) 226-3753: Urgent Care
(800) 383-4600: Customer Service Numbers
(800) 341-9211

Hours:

Monday – Saturday (Urgent Care) 7:30 a.m. - 8:30 p.m.
Everyday (Emergency Services) 24 hours a day

Martin Luther King MACC

12021 S. Wilmington Ave., Los Angeles, CA 90059

(310) 668-4321: Main
(310) 668-4426: Urgent Care

Hours:

Monday – Friday (Urgent Care) 8:00 a.m. - 4:30 p.m.
Everyday (Urgent Care) 7:30 a.m. - 11:00 p.m.

Olive View-UCLA Medical Center

14445 Olive View Dr., Sylmar, CA 91342

(818) 364-1555: Main
(818) 364-4311: Urgent Care

Hours:

Monday – Friday (Urgent Care) 8:00 a.m. - 8:00 p.m.
Saturday (Urgent Care) 8:00 a.m. - 4:00 p.m.
Everyday (Emergency Services) 24 hours a day

Royal Comprehensive Health Center

245 S. Fetterly St., Los Angeles, CA 90022

(323) 890-2373: Main
(800) 383-4600: Appointments
(323) 780-2433: Urgent Care

Hours:

Monday – Friday 8:00 a.m. - 5:00 p.m.
Monday – Friday (Walk-in) 7:00 a.m. - 5:00 p.m.
Saturday (Walk-in) 8:30 a.m. - 5:00 p.m.

South Valley Health Center

38350 40th St. East, Palmdale, CA 93550

(661) 272-5010: Main
(661) 945-8205: Appointments
(661) 272-5050: Urgent Care

Hours:

Monday – Friday 8:00 a.m. - 8:30 p.m.
Everyday (Urgent Care) 8:00 a.m. - 12 Midnight

Appendix I

Los Angeles County Department of Health Services, PUBLIC HOSPITALS

Harbor/UCLA Medical Center

1000 W. Carson St., Torrance, CA 90502

(310) 222-2345

LAC+USC Medical Center

1220 N. State St., Los Angeles, CA 90033

(323) 226-2622

Olive View-UCLA Medical Center

14445 Olive View Dr., Sylmar, CA 91342

(818) 364-1555

Appendix J

Other ATDs: Signs & Symptoms and What to do if Observed

Other aerosol transmissible diseases (ATDs), like pertussis, measles, mumps, rubella (“German measles”) and chicken pox, should also be considered when shelter staff screens clients. The following is a brief list that should prompt shelter staff to make a referral to a health care provider for further evaluation when identified through a screening process:

- Severe coughing spasms, especially if persistent; coughing fits may interfere with eating, drinking and breathing – **consider pertussis (whooping cough)**
- Fever, headache, muscle aches, tiredness, poor appetite followed by painful, swollen salivary glands on one side or both sides of face in front of ears or under jaw – **consider mumps**
- Fever, chills, cough, runny nose, watery eyes associated with onset of an unexplained rash (diffuse rash or blister-type skin rash) – **consider measles or chickenpox**
- Fever, headache, stiff neck, possibly mental status changes – **consider meningococcal disease**
- Health officials may issue alerts for community outbreaks of other diseases. They will provide screening criteria, and people must be referred to medical providers as recommended by the health officer.

If a shelter client has any of these symptoms, then shelter staff should immediately give them a surgical mask to wear, place them in a separate room away from other individuals, and contact the Department of Public Health on-call medical officer by calling the following phone number:

24-hour Communicable Disease Emergency Line

(888) 397-3993

If the shelter staff member’s phone discussion with the on-call medical officer suspects that the client has an ATD, then the on-call medical officer should assist the shelter to arrange for the client to be transferred to a hospital emergency room under ATD precautions.

The on-call medical officer should also transmit specific instructions to the emergency room staff to place the symptomatic client in isolation for ATDs (negative pressure room desirable) and to further assess the client.

EXHIBIT F

References

JANITORIAL AND CUSTODIAL SERVICES

- San Francisco City and County Department of Public Health. (2011). *Preventing Aerosol Transmissible Disease: A Reference Guide for Homeless Shelters and Residential Treatment Facilities*. <http://tinyurl.com/SFTBShelterGuidelines>.
- Francis J. Curry. (2011). *Tuberculosis Infection Control: A Practical Manual for Preventing TB*, p. 133.
- Centers for Disease Control and Prevention, Updated Guidelines for Using Interferon Gamma Release Assays to Detect Mycobacterium tuberculosis infection---United States, (2010). Recommendations and Reports, 59(RR05);1-25.
- Cal/OSHA Consultation Service Overview:
http://www.dir.ca.gov/dosh/dosh_publications/ConsultOverview.pdf
- How Cal/OSHA Consultation Service can help you with your workplace safety and health needs (rev. Feb 2013) --
http://www.dir.ca.gov/dosh/dosh_publications/consult.pdf#zoom=100
- Title 8, California Code of Regulations:
 - Section 5199, *Aerosol Transmissible Diseases*
<http://www.dir.ca.gov/title8/5199.html>
 - Section 5199, Appendix F (of the actual ATD Standard document) *Sample Screening Criteria for Work Settings Where No Health Care Providers Are Available (non-mandatory)*
<http://www.dir.ca.gov/title8/5199f.html>
 - Section 5144, *Respiratory Protection*
<http://www.dir.ca.gov/title8/5144.html>
 - Section 3203, *Injury and Illness Prevention Program*
<http://www.dir.ca.gov/title8/3203.html>
 - Section 3204, *Access to Employee Exposure and Medical Records*
<http://www.dir.ca.gov/title8/3204.html>

GL1-7199	AI	CERTIFICATE OF COVERAGE	10/16/2018
----------	----	--------------------------------	------------

<p>CSAC Excess Insurance Authority C/O ALLIANT INSURANCE SERVICES, INC. PO BOX 6450 NEWPORT BEACH, CA 92658-6450</p> <p>PHONE (949) 756-0271 / FAX (619) 699-0901 LICENSE #0C36861</p>	<p>THIS CERTIFICATE IS ISSUED AS A MATTER OF INFORMATION ONLY AND CONFERS NO RIGHTS UPON THE CERTIFICATE HOLDER. THIS CERTIFICATE DOES NOT AFFIRMATIVELY OR NEGATIVELY AMEND, EXTEND OR ALTER THE COVERAGE AFFORDED BELOW. THIS CERTIFICATE OF COVERAGE DOES NOT CONSTITUTE A CONTRACT BETWEEN THE ISSUING INSURER(S), AUTHORIZED REPRESENTATIVE OR PRODUCER, AND THE CERTIFICATE HOLDER.</p> <p>IMPORTANT: If the certificate holder is an ADDITIONAL INSURED and/or requesting a WAIVER OF SUBROGATION, the Memorandums of Coverage must be endorsed. A statement on this certificate does not confer rights to the certificate holder in lieu of such endorsement(s).</p>
	<p>COVERAGE AFFORDED A - CSAC Excess Insurance Authority</p>

<p>Member: SONOMA COUNTY ATTN: JANELL CRANE 575 ADMINISTRATION DR., #116-C SANTA ROSA, CA 95403-2881</p>	<p>COVERAGE AFFORDED B</p> <p>COVERAGE AFFORDED C</p> <p>COVERAGE AFFORDED D</p>
---	---

Coverages
 THIS IS TO CERTIFY THAT THE MEMORANDUMS OF COVERAGE LISTED BELOW HAVE BEEN ISSUED TO THE MEMBER NAMED ABOVE FOR THE PERIOD INDICATED, NOTWITHSTANDING ANY REQUIREMENT, TERM OR CONDITION OF ANY CONTRACT OR OTHER DOCUMENT WITH RESPECT TO WHICH THIS CERTIFICATE MAY BE ISSUED OR MAY PERTAIN. THE COVERAGE AFFORDED BY THE MEMORANDUMS DESCRIBED HEREIN IS SUBJECT TO ALL THE TERMS, EXCLUSIONS, AND CONDITIONS OF SUCH MEMORANDUMS. LIMITS SHOWN MAY HAVE BEEN REDUCED BY PAID CLAIMS.

CO LTR	TYPE OF COVERAGE	MEMORANDUM NUMBER	COVERAGE EFFECTIVE DATE (MM/DD/YYYY)	COVERAGE EXPIRATION DATE (MM/DD/YYYY)	LIABILITY LIMITS
A	<input checked="" type="checkbox"/> Excess General Liability	EIA 18 EL-26	07/01/2018	07/01/2019	\$2,000,000
	<input checked="" type="checkbox"/> Auto Liability				\$2,000,000
					Limits inclusive of the Member's Self-Insured Retention of \$1,000,000

Description of Operations/Locations/Vehicles/Special Items:

AS RESPECTS LICENSE AGREEMENT BETWEEN SONOMA COUNTY AND CALIFORNIA MILITARY DEPARTMENT FOR USE OF FACILITY AT SANTA ROSA NATIONAL GUARD ARMORY, 1500 ARMORY DR, SANTA ROSA, CA AS AN EMERGENCY HOMELESS SHELTER THROUGH 7/1/2019.

THE UNITED STATES, STATE OF CALIFORNIA, ITS OFFICERS, AGENTS, EMPLOYEES, AND SERVANTS ARE INCLUDED AS ADDITIONAL COVERED PARTIES, BUT ONLY INsofar AS THE OPERATIONS UNDER THIS CONTRACT ARE CONCERNED.

<p>Certificate Holder</p> <p>CALIFORNIA MILITARY DEPARTMENT 9800 GOETHE RD, BOX 18 SACRAMENTO, CA 95826</p>	<p>Cancellation SHOULD ANY OF THE ABOVE DESCRIBED MEMORANDUMS OF COVERAGES BE CANCELLED BEFORE THE EXPIRATION DATE THEREOF, NOTICE WILL BE DELIVERED IN ACCORDANCE WITH THE MEMORANDUMS OF COVERAGE PROVISIONS.</p> <p>AUTHORIZED REPRESENTATIVE</p> 
--	---

ENDORSEMENT NO. U-1

**CSAC EXCESS INSURANCE AUTHORITY
GENERAL LIABILITY 1**

ADDITIONAL COVERED PARTY AMENDATORY ENDORSEMENT

It is agreed that the "**Covered Party**, Covered Persons or Entities" section of the Memorandum is amended to include the person or organization named on the Certificate of Coverage, but only with respect to liability arising out of premises owned by or rented to the Member, or operations performed by or on behalf of the Member or such person or organization so designated.

Coverage provided under this endorsement is limited to the lesser of the limits stated on the Certificate of Coverage or the minimum limits required by contract.

ADDITIONAL COVERED PARTY:

NAME OF PERSON OR ORGANIZATION SCHEDULED PER ATTACHED CERTIFICATE OF COVERAGE

AS RESPECTS:

PER ATTACHED CERTIFICATE OF COVERAGE

It is further agreed that nothing herein shall act to increase the Authority's limit of liability.

This endorsement is part of the Memorandum and takes effect on the effective date of the Memorandum unless another effective date is shown below. All other terms and conditions remain unchanged.

Effective Date: _____

Memorandum No.: EIA 18 EL-00

Issued to: ALL MEMBERS

Issue Date: June 25, 2018



Authorized Representative
CSAC Excess Insurance Authority

EXHIBIT E



DEPARTMENT OF THE ARMY AND AIRFORCE
NATIONAL GUARD BUREAU
INDUSTRIAL HYGIENE SOUTHWEST
10510 SUPERFORTRESS AVENUE, SUITE C
MATHER CA 95655

ARNG-CSG-P

20 December 2017

MEMORANDUM THRU California Army National Guard, State Occupational Health Nurse (OHN), ATTN: Ms. Marianne Anderson, 9800 Goethe Road (Box 33), Sacramento, California, 95826

FOR California Army National Guard, State Safety and Occupational Health Manager (SOHM), ATTN: LTC William Germann, 9800 Goethe Road (Box 2), Sacramento, California, 95826

SUBJECT: Report of Industrial Hygiene FY17 Annual Lead Dust Surveys - Lead Dust Samples Above the ARNG Standard of 40 $\mu\text{g}/\text{ft}^2$

1. References

- a. ARNG-CSG All States Memorandum, SUBJECT: Possible Lead Dust Hazard in Army National Guard (ARNG) Readiness Centers, dated 23 September 2015.
- b. DODI 6055.01 Appendix to Enclosure 4, Implementing Guidance for Controlling Surface Contamination in Operations using Lead, Hexavalent Chromium, and Cadmium, dated 14 OCT 2014
- c. Army National Guard (ARNG), Industrial Hygiene Sampling Guide for Surface Lead Dust in Readiness Centers (RC), dated 27 OCT 2015.

2. Background

a. At the request of the NGB Industrial Hygiene Southwest (IHSW) Region through Federal Occupational Health and Resource Management Group, annual surface lead dust surveys were performed at CAARNG facilities during the months of July through October of 2017. The visits are intended to assist the CAARNG with meeting the annual lead surface wipe requirements within CAARNG Readiness Centers (RCs) and armories.

3. Considerations

- a. Use of trademark names within this report does not imply Army National Guard endorsement of any product.
- b. This survey was conducted to assist commanders and ARNG leaders with assessing health risks from lead dust contamination to members of the public who may enter ARNG RCs and armories. Risk Assessment Codes (RACs) are assigned to hazards that may require an abatement plan concerning DoD and Army employees. RACs are not applicable, nor assigned, to recommendations made in this report for civilian populations.

ARNG-CSG-P

SUBJECT: Report of Industrial Hygiene FY17 Annual Lead Dust Surveys - Lead Dust Samples Above the ARNG Standard of 40 µg/ft²

4. Observations

a. (RAC 2) The following facilities presented one or more sample locations noted on the enclosed facility floor plan(s) and laboratory sample analysis results indicating surface lead particulate (dust) above the ARNG standard of 40 µg/ft²:

Facility Name	Street Address	City	State	Zip	Collected Date	SAMPLE TYPE	Vendor	IH/Tech	Lab
AUBURN ARMORY	1273 HIGH STREET	AUBURN	CA	95603	7/20/2017	WIPE	USIH	McGlothlin	FOH
AZUSA ARMORY (SIERRA MADRE)	1351 WEST SIERRA MADRE AVENUE	AZUSA	CA	91702	8/31/2017	WIPE	PEAK	Weisbrod	FOH
BAKERSFIELD ARMORY (P STREET)	1512 SOUTH P STREET	BAKERSFIELD	CA	93827	7/24/2017	WIPE	PEAK	Wiesbrod	FOH
BANNING ARMORY	2041 WEST NICOLET STREET	BANNING	CA	92220	8/15/2017	WIPE	PEAK	Wiesbrod	FOH
BARSTOW ARMORY	1601 ARMORY BOULEVARD	BARSTOW	CA	92311	8/14/2017	WIPE	PEAK	Weisbrod	FOH
BELL ARMORY	5631 RICKENBACKER ROAD	BELL	CA	90201	10/5/2017	WIPE	PEAK	Weisbrod	FOH
BENICIA ARMORY	711 HILCREST AVENUE	BENICIA	CA	94510	8/1/2017	WIPE	USIH	McGlothlin	FOH
BRAWLEY ARMORY	650 NORTH SECOND STREET	BRAWLEY	CA	92227	7/19/2017	WIPE	PEAK	Wiesbrod	FOH
BURBANK ARMORY	3800 WEST VALHALLA DRIVE	BURBANK	CA	91505	9/31/2017	WIPE	PEAK	Weisbrod	FOH
CAMP SAN LUIS OBISPO BLDG 1310	10 SONOMA AVENUE	SAN LUIS OBISPO	CA	93405	7/14/2017	WIPE	USIH	Lucas	FOH
CAMP SAN LUIS OBISPO BLDG 1323	10 SONOMA AVENUE	SAN LUIS OBISPO	CA	93405	7/25/2017	WIPE	USIH	Lucas	FOH
CAMP SAN LUIS OBISPO BLDG 631	10 SONOMA AVENUE	SAN LUIS OBISPO	CA	93405	7/14/2017	WIPE	USIH	Lucas	FOH
CAMP SAN LUIS OBISPO BLDG 718	10 SONOMA AVENUE	SAN LUIS OBISPO	CA	93405	7/13/2017	WIPE	USIH	Lucas	FOH
CAMP SAN LUIS OBISPO BLDG 743	10 SONOMA AVENUE	SAN LUIS OBISPO	CA	93405	7/13/2017	WIPE	USIH	Lucas	FOH
COLTON ARMORY	423 EAST B STREET	COLTON	CA	92324	8/15/2017	WIPE	PEAK	Weisbrod	FOH
CONCORD ARMORY	2925 WILLOW PASS ROAD	CONCORD	CA	94519	9/12/2017	WIPE	USIH	Lucas	FOH
EL CAJON ARMORY	451 NORTH PIERCE STREET	EL CAJON	CA	92020	9/6/2017	WIPE	USIH	Lucas	FOH
ESCONDIDO ARMORY	304 EAST PARK AVENUE	ESCONDIDO	CA	92025	8/8/2017	WIPE	USIH	Lucas	FOH
EUREKA ARMORY	3517 WEST STREET	EUREKA	CA	95503	8/24/2017	WIPE	USIH	Lucas	FOH
FRESNO ARMORY (AIRWAYS)	5545 EAST AIRWAYS BOULEVARD	FRESNO	CA	93727	7/27/2017	WIPE	PEAK	Weisbrod	FOH
FRESNO ARMORY (CHANCE)	911 SOUTH CHANCE AVENUE	FRESNO	CA	93702	7/29/2017	WIPE	PEAK	Weisbrod	FOH
FRESNO ARMORY (DAKOTA)	5140 EAST DAKOTA AVENUE	FRESNO	CA	93727	7/26/2017	WIPE	PEAK	Weisbrod	FOH
FRESNO ARMORY (HAMMER FIELD)	5575 EAST AIRWAYS BOULEVARD	FRESNO	CA	93727	7/26/2017	WIPE	PEAK	Weisbrod	FOH
FRESNO NAVY RC (TASMG HQ)	5565 EAST AIRWAYS BOULEVARD	FRESNO	CA	93727	7/26/2017	WIPE	PEAK	Weisbrod	FOH
FULLERTON ARMORY	400 SOUTH BROOKHURST ROAD	FULLERTON	CA	92833	8/29/2017	WIPE	PEAK	Weisbrod	FOH
GILROY ARMORY	8490 WREN AVENUE	GILROY	CA	95020	8/4/2017	WIPE	USIH	McGlothlin	FOH
GLENDALE ARMORY	220 EAST COLORADO STREET	GLENDALE	CA	91205	8/31/2017	WIPE	PEAK	Weisbrod	FOH
HANFORD ARMORY	902 NORTH 11TH AVENUE	HANFORD	CA	93230	7/25/2017	WIPE	PEAK	Weisbrod	FOH
INDIO ARMORY	43143 JACKSON STREET	INDIO	CA	92201	7/19/2017	WIPE	PEAK	Wiesbrod	FOH
JFTB LOS ALAMITOS BLDG 36	4216 CONSTITUTION AVENUE	JFTB LOS ALAMITOS	CA	90720	9/16/2017	WIPE	PEAK	Weisbrod	FOH
JFTB LOS ALAMITOS BLDG 37	4506 DOOLITTLE AVENUE	JFTB LOS ALAMITOS	CA	90720	9/13/2017	WIPE	PEAK	Weisbrod	FOH
JFTB LOS ALAMITOS BLDG 98	4312 DOOLITTLE AVENUE	JFTB LOS ALAMITOS	CA	90720	9/11/2017	WIPE	PEAK	Weisbrod	FOH
JFTB LOS ALAMITOS HANGAR 2	4404 DOOLITTLE AVENUE	JFTB LOS ALAMITOS	CA	90720	9/11/2017	WIPE	PEAK	Weisbrod	FOH
LODI ARMORY	333 WASHINGTON AVENUE	LODI	CA	95249	7/19/2017	WIPE	USIH	McGlothlin	FOH
LONG BEACH ARMORY (7TH ST)	854 EAST 7TH STREET	LONG BEACH	CA	90813	8/29/2017	WIPE	PEAK	Weisbrod	FOH
LONG BEACH ARMORY (REDONDO)	2200 REDONDO AVENUE	LONG BEACH	CA	90809	8/29/2017	WIPE	PEAK	Weisbrod	FOH
LOS ANGELES ARMORY	1300 FEDERAL AVENUE	LOS ANGELES	CA	90025	8/30/2017	WIPE	PEAK	Weisbrod	FOH
MADERA ARMORY	701 EAST YOSEMITE AVENUE	MADERA	CA	93638	7/17/2017	WIPE	USIH	McGlothlin	FOH
MANHATTAN BEACH ARMORY	3601 BELL AVENUE	MANHATTAN BEACH	CA	90266	8/30/2017	WIPE	PEAK	Weisbrod	FOH
MATHER ARMORY (SUPERFORTRESS)	10516 SUPERFORTRESS AVENUE	MATHER	CA	95655	7/19/2017	WIPE	USIH	McGlothlin	FOH
MERCED ARMORY	1240 WEST 8TH STREET	MERCED	CA	95341	7/17/2017	WIPE	USIH	McGlothlin	FOH
MODESTO ARMORY (ROUSE)	630 ROUSE AVENUE	MODESTO	CA	95351	7/18/2017	WIPE	USIH	McGlothlin	FOH
NATIONAL CITY ARMORY	303 PALM AVENUE	NATIONAL CITY	CA	91950	9/6/2017	WIPE	USIH	Lucas	FOH
OAKDALE ARMORY	800 SOUTH YOSEMITE AVENUE	OAKDALE	CA	95361	7/27/2017	WIPE	PEAK	Weisbrod	FOH
OROVILLE ARMORY	1125 POMONA AVENUE	OROVILLE	CA	95965	8/16/2017	WIPE	USIH	Lucas	FOH
OXNARD ARMORY	351 SOUTH K STREET	OXNARD	CA	93030	7/17/2017	WIPE	USIH	Lucas	FOH
PALMDALE ARMORY	38315 30TH STREET	PALMDALE	CA	93550	8/14/2017	WIPE	PEAK	Weisbrod	FOH
PALMDALE ARMORY	38315 30TH STREET	PALMDALE	CA	93550	8/14/2017	WIPE	PEAK	Weisbrod	FOH
PETALUMA ARMORY	580 VALLEJO STREET	PETALUMA	CA	94952	9/12/2017	WIPE	USIH	Lucas	FOH
PLACERVILLE ARMORY	212 ARMORY ROAD	PLACERVILLE	CA	95667	6/23/2017	WIPE	PEAK	Weisbrod	FOH
PORTERVILLE ARMORY	29 NORTH PLANO STREET	PORTERVILLE	CA	93257	7/24/2017	WIPE	PEAK	Weisbrod	FOH
RED BLUFF ARMORY	2000 PARK AVENUE	RED BLUFF	CA	96080	8/18/2017	WIPE	USIH	Lucas	FOH
REDDING ARMORY	3025 SOUTH STREET	REDDING	CA	96001	8/18/2017	WIPE	USIH	Lucas	FOH
REDLANDS ARMORY	617 TEXAS STREET	REDLANDS	CA	93257	8/17/2017	WIPE	PEAK	Weisbrod	FOH
REDWOOD CITY ARMORY	939 VAOLTA ROAD	REDWOOD CITY	CA	94061	8/2/2017	WIPE	USIH	McGlothlin	FOH
REEDLEY ARMORY	601 EAST 11TH STREET	REEDLEY	CA	93654	7/25/2017	WIPE	PEAK	Weisbrod	FOH
RICHMOND ARMORY	624 CARLSON BOULEVARD	RICHMOND	CA	94804	6/28/2017	WIPE	USIH	Lucas	FOH
ROSEVILLE ARMORY	850 ALL AMERICAN CITY BOULEVARD	ROSEVILLE	CA	95678	7/20/2017	WIPE	USIH	McGlothlin	FOH
SACRAMENTO ARMORY (ARDEN)	440 ARDEN WAY	SACRAMENTO	CA	95815	7/14/2017	WIPE	USIH	McGlothlin	FOH
SACRAMENTO ARMORY (B STREET)	2814 B STREET	SACRAMENTO	CA	95816	7/14/2017	WIPE	USIH	McGlothlin	FOH
SACRAMENTO ARMORY (MEADOWVIEW)	3250 MEADOWVIEW ROAD	SACRAMENTO	CA	95832	7/14/2017	WIPE	USIH	McGlothlin	FOH
SAN BRUNO ARMORY	455 3RD AVENUE	SAN BRUNO	CA	94066	8/2/2017	WIPE	USIH	McGlothlin	FOH
SAN FRANCISCO ARMORY	1800 MISSION STREET	SAN FRANCISCO	CA	94103	8/3/2017	WIPE	USIH	McGlothlin	FOH
SAN JOSE ARMORY	251 WEST HEDDING STREET	SAN JOSE	CA	95110	7/12/2017	WIPE	USIH	McGlothlin	FOH
SAN PEDRO ARMORY (FT MCCARTHUR)	891 WEST 13TH STREET	SAN PEDRO	CA	90731	8/29/2017	WIPE	PEAK	Weisbrod	FOH
SAN RAFAEL BLDG 153	153 MADISON AVENUE	SAN RAFAEL	CA	94903	6/29/2017	WIPE	USIH	Lucas	FOH

ARNG-CSG-P

SUBJECT: Report of Industrial Hygiene FY17 Annual Lead Dust Surveys - Lead Dust Samples Above the ARNG Standard of 40 µg/ft²

Facility Name	Street Address	City	State	Zip	Collected Date	SAMPLE TYPE	Vendor	IH/Tech	Lab
SANTA ANA ARMORY	612 EAST WARNER AVENUE	SANTA ANA	CA	92707	8/28/2017	WIPE	PEAK	Weisbrod	FOH
SANTA BARBARA ARMORY	700 EAST CANON PERDIDO STREET	SANTA BARBARA	CA	93103	7/18/2017	WIPE	USIH	Lucas	FOH
SANTA CRUZ ARMORY	301 ARMORY ROAD	SANTA CRUZ	CA	95065	7/21/2017	WIPE	USIH	Lucas	FOH
SANTA MARIA ARMORY	937 SOUTH THORNBURG STREET	SANTA MARIA	CA	93458	7/20/2017	WIPE	USIH	Lucas	FOH
SANTA ROSA ARMORY	1500 ARMORY DRIVE	SANTA ROSA	CA	95401	8/25/2017	WIPE	USIH	Lucas	FOH
STOCKTON ARMORY	8010 SOUTH AIRPORT WAY	STOCKTON	CA	95206	7/18/2017	WIPE	USIH	McGlothlin	FOH
SUSANVILLE ARMORY	200 RUSSEL AVENUE	SUSANVILLE	CA	96130	8/17/2017	WIPE	USIH	Lucas	FOH
SYLMAR ARMORY	12860 ARROYO DRIVE	SYLMAR	CA	91342	9/1/2017	WIPE	PEAK	Weisbrod	FOH
TULARE ARMORY	649 EAST CROSS AVENUE	TULARE	CA	93274	7/25/2017	WIPE	PEAK	Weisbrod	FOH
TURLOCK ARMORY	1040 FLOWER STREET	TURLOCK	CA	95380	7/17/2017	WIPE	USIH	McGlothlin	FOH
VALLEJO ARMORY	200 BENNETT AVENUE	VALLEJO	CA	94590	7/21/2017	WIPE	USIH	McGlothlin	FOH
VENTURA ARMORY	1270 ARUNDELL AVENUE	VENTURA	CA	93003	7/17/2017	WIPE	USIH	Lucas	FOH
VISALIA ARMORY	1100 NORTH AKERS ROAD	VISALIA	CA	93291	7/25/2017	WIPE	PEAK	Weisbrod	FOH
WALNUT CREEK ARMORY	1800 CARMEL DRIVE	WALNUT CREEK	CA	94596	9/11/2017	WIPE	USIH	Lucas	FOH
YREKA ARMORY	1710 FAIRLANE ROAD	YREKA	CA	96097	8/23/2017	WIPE	USIH	Lucas	FOH
YUBA ARMORY	310 B STREET	YUBA	CA	95991	8/17/2017	WIPE	USIH	Lucas	FOH

5. Recommendations

a. IAW Memorandum for Chiefs of Staff of All States, Puerto Rico, the US Virgin Islands, Guam and the District of Columbia, Possible Lead Dust Hazard in Army National Guard (ARNG) Readiness Centers, dated 23 September 2015, immediately discontinue public rental and public entry to the facility.

b. Provide additional housekeeping or lead remediation as necessary to reduce lead dust particulates below the ARNG standard of 40 µg/ft².

c. Resample using the ARNG Lead Sampling Guide to verify reduction of lead dust particulates to below the ARNG standard of 40 µg/ft². The facility may be reopened for public use and entry after verification of housekeeping/remediation and resampling has been made.

d. Continue best management practices by following good housekeeping procedures. Regular housekeeping can reduce or eliminate hazards from lead particulates, including lead dust.

e. Practice Preventive Medicine Measures (PPM) to reduce health risks from lead dust. Provide education beginning at the lowest level (individual) through the highest levels (commands and community/public). Provide notification of health hazards present to all potential occupants of ARNG facilities.

f. Medical surveillance is not recommended, as OSHA does not have a Permissible Exposure Level (PEL) published for surface metal particulates to determine if an individual has been exposed. Individuals who have concerns of lead exposures through inhalation, ingestion, or dermal absorption should contact their Primary Care Provider (PCP) or the State Occupational Health Nurse.

ARNG-CSG-P

SUBJECT: Report of Industrial Hygiene FY17 Annual Lead Dust Surveys - Lead Dust Samples Above the ARNG Standard of 40 $\mu\text{g}/\text{ft}^2$

6. Point of contact is the undersigned of at (916) 854-1490 or genise.n.carpenter.civ@mail.mil









GENISE N. CARPENTER
GS-12, DAC, NGB-IHSW
Regional Industrial Hygienist

Encl

SUBJECT: Executive Summary for Industrial Hygiene Site Assistance Visit (IHSAV) for Santa Rosa Armory, 1500 Armory Drive, Santa Rosa CA, conducted on 25 AUG 2017

Lead Wipe Sample Project









Santa Rosa Armory Field Data Sheet

California	Santa Rosa Armory	25 AUG 2017		
Sampling Performed By:	Andrew Lucas, CIH			
Status of IFR at this RC:	None			
Sample ID Number	Room/Area	Surface	Result $\mu\text{g}/\text{ft}^2$	Photo
CASARO1	Room 5, Kitchen	Counter	<5.0	
CASARO2	Room 5, Kitchen	Floor	<5.0	
CASARO3	Room 9	Table	<5.0	
CASARO4	Room 9	Floor	11	
CASARO5	Room 11	Desk	<5.0	
CASARO6	Room 11	Floor	11	

SUBJECT: Executive Summary for Industrial Hygiene Site Assistance Visit (IHSAV) for Santa Rosa Armory, 1500 Armory Drive, Santa Rosa CA, conducted on 25 AUG 2017

CASARO7	Room 12	Desk	6.8	
CASARO8	Room 12	Floor	258	
CASARO9	Room 13, Medical section	Desk	10	
CASARO10	Room 13, Medical section	Floor	25	
CASARO11	Room 14, Supply	Table	9.6	
CASARO12	Room 14, Supply	Floor	28	
CASARO13	Room 15	Table	<5.0	
CASARO14	Room 15	Floor	7.0	

SUBJECT: Executive Summary for Industrial Hygiene Site Assistance Visit (IHSAV) for Santa Rosa Armory, 1500 Armory Drive, Santa Rosa CA, conducted on 25 AUG 2017

CASARO15	Room 16	Desk	<5.0	
CASARO16	Room 16	Floor	<5.0	
CASARO17	Room 29, Annex S1	Bookcase	<5.0	
CASARO18	Room 28, Annex S1	Desk	<5.0	
CASARO19	Room 26	Desk	<5.0	
CASARO20	Room 25	Desk	<5.0	
CASARO21	Drill floor	Table	<5.0	
CASARO22	Drill floor	Floor	<5.0	

ARNG-CSG-P

SUBJECT: Executive Summary for Industrial Hygiene Site Assistance Visit (IHSAV) for Santa Rosa Armory, 1500 Armory Drive, Santa Rosa CA, conducted on 25 AUG 2017

CASARO23	Room 14A, Vault	Floor	63	
CASARO24	Field blank	Field blank	N/A	N/A
CASARO25	Field blank	Field blank	N/A	N/A

SUBJECT: Executive Summary for Industrial Hygiene Site Assistance Visit (IHSAV) for Santa Rosa Armory, 1500 Armory Drive, Santa Rosa CA, conducted on 25 AUG 2017

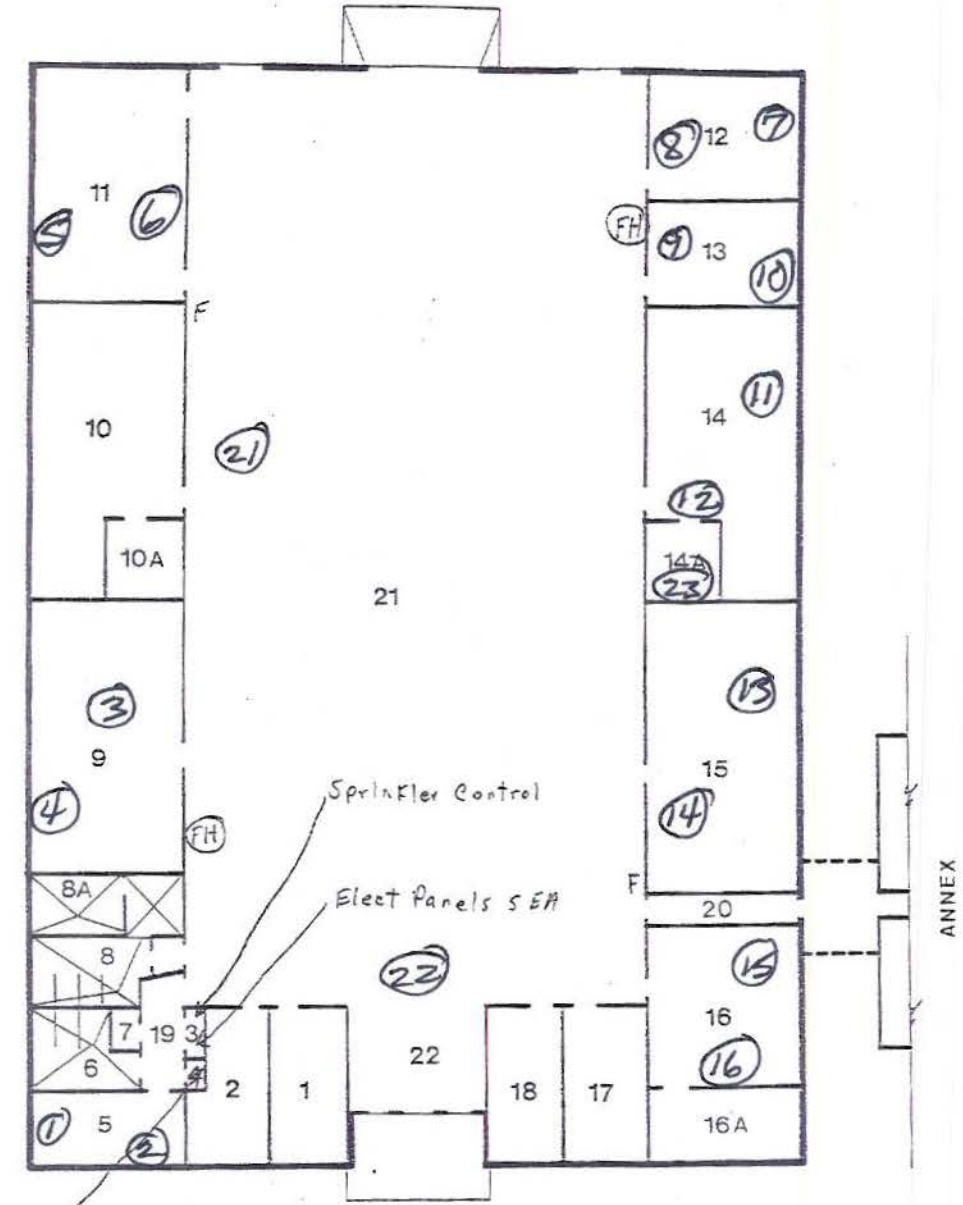

SANTA ROSA
FLOOR PLAN
SCALE = 1" = 20'
⊙ = LEAD WIPES SAMPLE

SUBJECT: Executive Summary for Industrial Hygiene Site Assistance Visit (IHSAV) for Santa Rosa Armory, 1500 Armory Drive, Santa Rosa CA, conducted on 25 AUG 2017

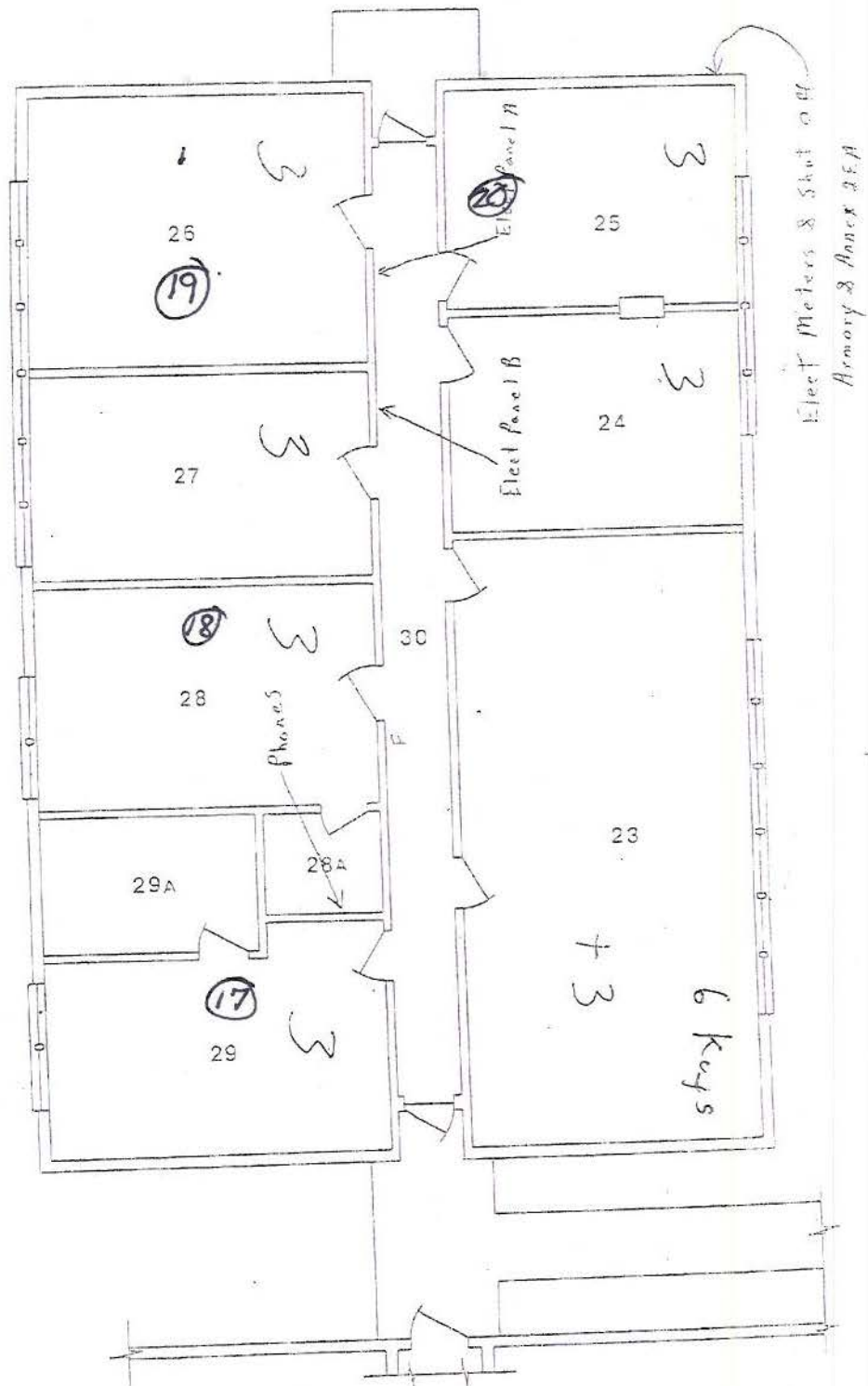

SANTA ROSA ANNEX

SCALE 1/8" = 1'-0"

⊙ = LEAD WIRE SAMPLE

SUBJECT: Executive Summary for Industrial Hygiene Site Assistance Visit (IHSAV) for Santa Rosa Armory, 1500 Armory Drive, Santa Rosa CA, conducted on 25 AUG 2017

PSC-FOH ENVIRONMENTAL LABORATORY

638 S. CLARK STREET CHICAGO, IL 60605 PHONE: (312) 888-0413 FAX: (312) 888-0434

ANALYTICAL REPORT

Submitted To: ARNG – Region SW IH Office
10510 Superfortress Ave., Ste. C
Mather, CA 95655

Attention: Ms. Genise N. Carpenter/Mr. Andrew Lucas, CIH

Submitted By: Ms. Michelle C. Stemmons

Reference Data: Lead
Sampling Site: NGB: Santa Rosa, CA
Sample Media: Ghost Wipe(s)®
Method Reference: OSHA ID-121
Project ID: Project 16538
DFOH Lab Nos.: TM-17-143897 through TM-17-143721
Date Received: 08/29/17
Data Analyzed: 08/22/17 – 08/25/17
Date Issued: 08/28/17

The wipe samples were hot plate digested. The samples were run on a Perkin Elmer flame atomic absorption spectrophotometer (AA).

General Lab Comments:

All quality control criteria have been met.

* All samples received in condition acceptable for analysis unless otherwise noted.

** Sample results have not been corrected for contamination based on the field blank or other analytical blank unless otherwise noted.

Analytical results are given on the enclosed tables. Results relate only to items tested. If you have any questions about these results, feel free to phone the Laboratory at (312) 888-0413.

Ms. Edna A. Bautista
Technical Manager

Ms. Michelle C. Stemmons
Laboratory Director



Project 16538
Page 1 of 2



SUBJECT: Executive Summary for Industrial Hygiene Site Assistance Visit (IHSAV) for Santa Rosa Armory, 1500 Armory Drive, Santa Rosa CA, conducted on 25 AUG 2017

PSC-FOH ENVIRONMENTAL LABORATORY

608 S. CLARK STREET CHICAGO, IL 60606 PHONE: (312) 888-0418 FAX: (312) 888-0434

LEAD on WIPE RESULTS

SAMPLE NUMBER*	LABORATORY NUMBER	CONCENTRATION (µg)	CONCENTRATION (µg/ft ²)
CA SARO 1	TM-17-143697	<5.0	<5.0
CA SARO 2	TM-17-143698	<5.0	<5.0
CA SARO 3	TM-17-143699	<5.0	<5.0
CA SARO 4	TM-17-143700	11	11
CA SARO 5	TM-17-143701	<5.0	<5.0
CA SARO 6	TM-17-143702	11	11
CA SARO 7	TM-17-143703	6.8	6.8
CA SARO 8	TM-17-143704	258	258
CA SARO 9	TM-17-143705	10	10
CA SARO 10	TM-17-143706	25	25
CA SARO 11	TM-17-143707	9.6	9.6
CA SARO 12	TM-17-143708	28	28
CA SARO 13	TM-17-143709	<5.0	<5.0
CA SARO 14	TM-17-143710	7.0	7.0
CA SARO 15	TM-17-143711	<5.0	<5.0
CA SARO 16	TM-17-143712	<5.0	<5.0
CA SARO 17	TM-17-143713	<5.0	<5.0
CA SARO 18	TM-17-143714	<5.0	<5.0
CA SARO 19	TM-17-143715	<5.0	<5.0
CA SARO 20	TM-17-143716	<5.0	<5.0
CA SARO 21	TM-17-143717	<5.0	<5.0
CA SARO 22	TM-17-143718	<5.0	<5.0
CA SARO 23	TM-17-143719	63	63
CA SARO 24**	TM-17-143720	<5.0	
CA SARO 25**	TM-17-143721	<5.0	

Surface Wipe Sampling Criteria

Metal	Acceptable Surface Level µg/ft ²	Basis for Criteria
Lead	200 for facilities (all surfaces)	NG Pam 420-15, Guidelines and Procedures for Rehabilitation and Conversion of Indoor Firing Ranges, 3 November 2006, http://www.ngbpic.ngb.army.mil/pubs/420/ngpam420_15.pdf
Lead	40 for any potentially child occupied areas of facility (all surfaces); used for armories with public access, family services offices, or other routine use by children	NG Pam 420-15, Guidelines and Procedures for Rehabilitation and Conversion of Indoor Firing Ranges, 3 November 2006, http://www.ngbpic.ngb.army.mil/pubs/420/ngpam420_15.pdf

Metals in Wipe Limits (based on one ft² sampled area)

Analyte	Analytical Method	Method Detection Limit	Minimum Reporting Limit
Lead	OSHA ID-121	2.5 µg/ft ²	5.0 µg/ft ²

Edna A. Bautista
 Ms. Edna A. Bautista
 Technical Manager



SUBJECT: Executive Summary for Industrial Hygiene Site Assistance Visit (IHSAV) for Santa Rosa Armory, 1500 Armory Drive, Santa Rosa CA, conducted on 25 AUG 2017

US PUBLIC HEALTH SERVICE, FEDERAL OCCUPATIONAL HEALTH CHAIN-OF-CUSTODY / FIELD DATA SHEET 10/23

Environmental Laboratory 536 N. Clark Street South, Suite 714 Chicago, IL 60605-1671 Tel: (312) 898 0412 Fax: (312) 898-0434 Attn: Michele Steinhilber		PROJECT REFERENCE Agreement No.: A 106644 Statement of Work No.: S 219942 Project No.: P 219945		File No.: 16538 File Date: Date Rec'd: 08/25/17 Date Rec'd: 08/25/17 Date Rec'd: 08/25/17	
		Agency: CA ARNG Project Manager: SANTA ROSA		Analytical Method: (STC - Standard) Analytical Method: (STC - Standard) Analytical Method: (STC - Standard)	
Name: ANDY LUCAS Address: 1500 ARMORY DRIVE, SANTA ROSA, CA 95402 Phone: 530-477-5722 Email: ANDY.LUCAS@USPHS.DHS.GOV		Agency: CA ARNG Project Manager: SANTA ROSA		Analytical Method: (STC - Standard) Analytical Method: (STC - Standard) Analytical Method: (STC - Standard)	
ID #	Sample	Sample Location / Description	Matrix	Volume	Lab ID #
CA SARO 1	TS	ROOM 5 KITCHEN COUNTER	1		TM-17-143697
2		" FLOOR			TM-17-143698
3		ROOM 9 TABLE			TM-17-143699
4		" FLOOR			TM-17-143700
5		ROOM 11 DESK TABLE			TM-17-143701
6		" FLOOR			TM-17-143702
7		ROOM 12 DESK			TM-17-143703
8		" FLOOR			TM-17-143704
9		ROOM 12 DESK MEDICAL SECTION			TM-17-143705
10		" FLOOR			TM-17-143706
Sample Size Code: 1-100 mg, 2-1000 mg, 3-10000 mg		Sample Media Code: 1-100 mg, 2-1000 mg, 3-10000 mg		Analyzed By: Andrew Lucas Date: 8/28/17	
Sample Size Code: 1-100 mg, 2-1000 mg, 3-10000 mg		Sample Media Code: 1-100 mg, 2-1000 mg, 3-10000 mg		Analyzed By: [Signature] Date: 8/29/17	

SUBJECT: Executive Summary for Industrial Hygiene Site Assistance Visit (IHSAV) for Santa Rosa Armory, 1500 Armory Drive, Santa Rosa CA, conducted on 25 AUG 2017

US PUBLIC HEALTH SERVICE, FEDERAL OCCUPATIONAL HEALTH CHAIN-OF-CUSTODY / FIELD DATA SHEET 2 of 3

Environmental Laboratory 636 S. Clark Street South, Suite 714 Chicago, IL 60606-1621 Tel: (312) 895-6413 Fax: (312) 895-6434 Attn: Michelle Stammers		PROJECT REFERENCE		For Lab Use Only Project Report # 16538 Date Date	
		Agreement No. A 106644 Statement of Work No. S 219942 Project No. P 219945 Agency CA ARNG Proj. Manager CA ARNG Location SANTA ROSA City, State	Samples Received: <input type="checkbox"/> Primary <input type="checkbox"/> Secondary <input type="checkbox"/> Tertiary <input type="checkbox"/> Other Date Received: 8/25/17 Received By: [Signature] Date Analyzed: 8/28/17 Analyzed By: [Signature]		Revision: 000 Date: 10/2/2010
Name: ANDY LUCAS Address: 1500 ARMORY DRIVE SANTA ROSA CA 95402 Phone/Fax: 707-547-2722 Email: ANDY.LUCAS@US.PHHS.GOV		Sample ID # 1175 Date 8/25/17 Time 11:00 AM Sample Location / Description ROOM 14 SUPPLY TABLE Lab ID # TM-17-143727		Analyzed By: [Signature] Date: 8/28/17	
ID # 12 Date 8/25/17 Time 11:00 AM Sample Location / Description 11 FLOOR Lab ID # TM-17-143728		ID # 13 Date 8/25/17 Time 11:00 AM Sample Location / Description ROOM 15 TABLE Lab ID # TM-17-143706		ID # 14 Date 8/25/17 Time 11:00 AM Sample Location / Description 11 FLOOR Lab ID # TM-17-143710	
ID # 15 Date 8/25/17 Time 11:00 AM Sample Location / Description ROOM 16 DESK Lab ID # TM-17-143711		ID # 16 Date 8/25/17 Time 11:00 AM Sample Location / Description 11 FLOOR Lab ID # TM-17-143712		ID # 17 Date 8/25/17 Time 11:00 AM Sample Location / Description ROOM 29 BOOKCASE Lab ID # TM-17-143713	
ID # 18 Date 8/25/17 Time 11:00 AM Sample Location / Description ROOM 28 DESK Lab ID # TM-17-143714		ID # 19 Date 8/25/17 Time 11:00 AM Sample Location / Description ROOM 26 DESK Lab ID # TM-17-143715		ID # 20 Date 8/25/17 Time 11:00 AM Sample Location / Description ROOM 25 DESK Lab ID # TM-17-143716	
Analyzed By: [Signature] Date: 8/28/17		Analyzed By: [Signature] Date: 8/28/17		Analyzed By: [Signature] Date: 8/28/17	

Applied to all samples and all parts of a sample of an emergency only. * Applies to all samples and parts of a sample. ** Applies to all samples and parts of a sample. *** Sample expires 90 days after date of collection.

ARNG-CSG-P

SUBJECT: Executive Summary for Industrial Hygiene Site Assistance Visit (IHSAV) for Santa Rosa Armory, 1500 Armory Drive, Santa Rosa CA, conducted on 25 AUG 2017

US PUBLIC HEALTH SERVICE, FEDERAL OCCUPATIONAL HEALTH CHAIN-OF-CUSTODY / FIELD DATA SHEET 34/2

Environmental Laboratory 536 S. Clark Street South, Suite 714 Chicago, IL 60605-1521 Tel: (312) 886-0413 Fax: (312) 886-0434 Attn: Michele Stamm		PROJECT REFERENCE Agreement No. A 106644 Abatement of Work No. S 219942 Project No. P 219943 Agency CA ARNG Local (City, State) SANTA ROSA		Project ID: 106638 Project Report # Due Date: Samples Received On: <input type="checkbox"/> YES <input type="checkbox"/> NO (circle one)		Rev. 07/2013				
				Water Sampling Method: Container Type: ETC Star Drive P.P. vs. Nitrate & Nitrite: Preservation: Chain of Custody:		Analyte(s) to be analyzed:				
Name: ANDY LUCAS Address: 2017 BOVICILLA AVE RICHMOND, CALIF. 94702 Phone/Fax: 925-477-2722 Email: ANDY.LUCAS@US-INDUSTRIAL-HYGIENE.COM		Name: ANDY LUCAS Address: 2017 BOVICILLA AVE RICHMOND, CALIF. 94702 Phone/Fax: 925-477-2722 Email: ANDY.LUCAS@US-INDUSTRIAL-HYGIENE.COM		Date: 8/29/17 Signature: <i>[Signature]</i> Title: <i>[Title]</i>		Date: 8/29/17 Signature: <i>[Signature]</i> Title: <i>[Title]</i>				
ID #	Sample		Sample Location / Description	Flow Rate (gpm)	Time (hr)	Temp (°F)	Wind (mph)	Dir	Lab ID #	Lead
	Lot	Batch								
CA SARD 2175			DRILL FLOOR TABLE						TM-17-43717	LEAD
22			4 FLOOR						TM-17-43718	
23			ROOM 144A VAULT FLOOR						TM-17-43719	
24			FIELD BLANK						TM-17-43720	
25			" "						TM-17-43721	

Copyright © 2013 by USPHS. All rights reserved. This document is the property of the U.S. Department of Health and Human Services. It is loaned to you and is not to be distributed outside your organization. For more information, contact the U.S. Department of Health and Human Services, Office of Occupational Safety and Health, 1015 North 17th Street, Washington, DC 20036-4502.

EXHIBIT F

JANITORIAL AND CUSTODIAL SERVICES

LICENSEE, at LICENSEE's sole cost and expense, shall furnish the following commercial janitorial services and supplies to PREMISES during the term of this LICENSE:

- A. Trash disposal,
- B. Janitorial services sufficient to maintain the interior in a clean well-maintained condition; that is, to eliminate all visible dirt, litter, grime, stains, etc., to the greatest practical degree possible, by performing at least the following:
 - (1) Empty and clean all trash containers, and dispose of all trash and rubbish.
 - (2) Clean and maintain in a sanitary and odor-free condition all floors, basins, toilet bowls, and urinals.
 - (3) Furnish and replenish all latrine toilet supplies (including soap, towels, seat covers, toilet tissue, and sanitary napkins). Furnish and replenish paper towel supply in all areas of the leased space.
 - (4) Sweep or dust mop all hard surface floors or carpeted areas, including stairways and halls. Offices with hard surface floors in the public lobby area shall be damp-mopped daily.
 - (5) Wash latrine mirrors, remove finger marks and smudges from all glass entrance doors.
 - (6) Specifically check and remove spots and/or spills from the floors, carpets, or stairways as needed, but not less frequently than the end of each occupancy period.
 - (7) Following the last day of use, PREMISES shall be deep cleaned, which includes the following:
 - a. The assembly hall shall be waxed and buffed to a high shine
 - b. The hallways shall be waxed to a high shine
 - c. The bathrooms shall be steam cleaned and disinfected to the highest degree removing stains and mold in grout and other discoloration and build up in showers and tiled areas.
 - d. If kitchen is used in any way, wipe down and disinfect kitchen area to include cleaning of all stainless steel counters and appliances.

EXHIBIT G



State of California

GOVERNMENT CODE

Section 15301

15301. (a) The El Centro and Calexico armories in Imperial County; the Culver City, Glendale, Inglewood, Long Beach 7th Street, Pomona, Sylmar, and West Los Angeles Federal Avenue armories in Los Angeles County; the San Rafael armory in Marin County; the Merced armory in Merced County; the Fullerton and Santa Ana armories in Orange County; the Roseville armory in Placer County; the Corona, Indio, and Riverside armories in Riverside County; the El Cajon, Escondido, and Vista armories in San Diego County; the Atascadero armory in San Luis Obispo County; the San Mateo armory in San Mateo County; the Santa Barbara and Santa Maria armories in Santa Barbara County; the Gilroy, San Jose Hedding Street, and Sunnyvale armories in Santa Clara County; the Santa Cruz and Watsonville armories in Santa Cruz County; the Redding armory in Shasta County; the Petaluma and Santa Rosa armories in Sonoma County; and the Oxnard and Ventura armories in Ventura County, shall be made available to these counties or a city in these counties for the purpose of providing temporary shelter for homeless persons during the period from October 15 through April 15 each year.

(b) The Adjutant General may, in his or her sole discretion, use alternate armories as may be necessary to meet the operational needs of the Military Department. Additionally, any county or city, including those not listed in subdivision (a), may use any armory within its jurisdiction subject to the approval of the Adjutant General.

(c) Subject to appropriation in the annual Budget Act, the Adjutant General may increase or decrease the number of days of operation among all of the armories funded in any year to best meet cold weather demands as they develop. The Adjutant General shall periodically report to the counties authorized to receive funds on the ongoing availability of remaining funded shelter days.

(Amended by Stats. 2016, Ch. 462, Sec. 1. (AB 2254) Effective January 1, 2017.)



State of California

GOVERNMENT CODE

Section 15301.1

15301.1. State armories shall not be made available during any period that any organization of the state militia or of the Armed Forces of the United States is conducting drills or other military training or activity at the armory or during any period that the armories have been designated by the Governor or the Adjutant General for use appropriate to a condition of emergency, including, but not limited to, use by the Red Cross during an earthquake, fire, or other disaster.

(Added by Stats. 1994, Ch. 1195, Sec. 1. Effective January 1, 1995.)



State of California

GOVERNMENT CODE

Section 15301.3

15301.3. Any county or city authorized in Section 15301 electing to use a state armory or armories for the purpose of this chapter, in consultation with the Community Advisory Committee appointed pursuant to Section 438 of the Military and Veterans Code or, if no committee has been appointed, in consultation with the Adjutant General, shall obtain a license from the Military Department with the following requirements:

(a) The county or city obtaining a license shall be solely responsible for measures and costs required to comply with state and local health and safety codes during the license periods.

(b) The county or city obtaining a license shall be responsible for all legal liabilities during the license periods and the state shall be held harmless in each case.

(c) Except as provided in the annual Budget Act, the county or city obtaining a license shall be responsible for all costs of providing shelter in the state armory or armories to homeless persons during the license periods, including, but not limited to, all costs for minor emergency repairs, including, but not limited to, plumbing and electrical work, and shall reimburse the Military Department for all costs of providing armories for shelter operations including, but not limited to, utilities, building maintenance and repair, administrative costs, and for National Guardsman for the security of military equipment and property.

(d) The county or city obtaining a license shall be solely responsible for alternative housing arrangements, including relocation measures and transportation, for homeless persons housed in state armories during the license periods, upon notification from the Military Department that the armory or armories shall be required for military activities or emergency purposes as announced by the Governor. The Military Department or the Governor shall determine the evacuation deadline.

(e) The county or city obtaining a license shall be responsible for providing uniformed security personnel from one hour before the shelter opens until one hour after lights out. The county or city shall also ensure that officers from the local law enforcement agency with jurisdiction over the armory will conduct periodic visits to the armory on each night of operation.

(f) The county or city obtaining a license shall be responsible for providing janitorial service from a licensed contractor or qualified civil service employees in order to meet state health and sanitation standards for restrooms and shower facilities.

(Amended by Stats. 2000, Ch. 958, Sec. 2. Effective January 1, 2001.)



State of California

GOVERNMENT CODE

Section 15301.6

15301.6. (a) Each county that obtains a license under Section 15301.3 shall establish a local shelter advisory committee, which shall have all of the following responsibilities:

- (1) To address issues related to shelter operation, including, but not limited to, sanitation and security issues.
- (2) To ensure that the shelter maintains a “good neighbor policy.”
- (3) To assist in finding long-term solutions for providing housing for the homeless to reduce the degree to which state armories are utilized as sites for housing homeless persons.

(b) The county shall select the advisory committee, which shall include representatives from the county and cities within the county in which armories are utilized, local government planning departments, the California National Guard, homeless service providers, local peace officers, representatives of affected community organizations, and advocates for homeless persons. Counties may utilize existing homeless task forces, including, but not limited to, a task force for purposes of the Federal Emergency Management Agency (FEMA), if the membership of the task force has representatives that meet all of the requirements of this subdivision.

(Amended by Stats. 2000, Ch. 958, Sec. 3. Effective January 1, 2001.)

**THE SOCIETY OF ST. VINCENT DE PAUL DISTRICT COUNCIL OF SONOMA
COUNTY, INC. ARMORY WINTER SHELTER
OPERATING AGREEMENT
FISCAL YEAR 2018-19**

The following is an agreement, dated for convenience as of November 19, 2018, by and between the Sonoma County Community Development Commission, hereinafter called "COMMISSION," and **The Society of St. Vincent de Paul, District Council of Sonoma Inc.**, hereinafter called "St. Vincent de Paul-Sonoma."

WITNESSETH:

WHEREAS, COMMISSION administers certain housing and community development activities with funding from federal, state, and local discretionary funding, hereinafter called "Funding"; and

WHEREAS, the County of Sonoma is entering into a license agreement with the State of California National Guard for use of the Santa Rosa Armory by St. Vincent de Paul-Sonoma in fiscal year 2018-19 for **Armory Winter Shelter**.

NOW, THEREFORE, COMMISSION and St. Vincent de Paul-Sonoma for and in consideration of their mutual promises and agreements herein contained do agree as follows:

1. Term of Agreement: St. Vincent de Paul-Sonoma agrees to provide the services described in this Agreement for a period beginning November 19, 2018 and continuing until March 3, 2019, unless extended by mutual written agreement of the parties hereto pursuant to paragraph 19 or terminated pursuant to paragraph 2.

2. Termination: At any time and without cause, COMMISSION shall have the right in its sole discretion, to terminate this Agreement by giving thirty (30) days written notice to ST. VINCENT DE PAUL-SONOMA. In such event, St. Vincent de Paul-Sonoma shall be entitled to receive full payment for all services satisfactorily rendered and expenses incurred hereunder.

If St. Vincent de Paul-Sonoma shall fail to perform any of its obligations hereunder, within the time and in the manner herein provided or otherwise violate any of the terms of this Agreement, COMMISSION may terminate this Agreement by giving St. Vincent de Paul-Sonoma written notice of such termination. St. Vincent de Paul-Sonoma shall have the right to initiate a cure for the default within thirty (30) days of the date of the written notice of termination of the Agreement for cause, and shall complete said cure within ninety (90) days of the date of the written notice of termination.

3. Scope of Services:

3.1 ST. VINCENT DE PAUL-SONOMA's Specified Services. St. Vincent de Paul-Sonoma shall, in a manner satisfactory to COMMISSION, perform the services set forth in the following checked exhibits, attached hereto and incorporated herein by specific reference and pursuant to Article 14, Prosecution of Work. In the event of a conflict between the body of this Agreement and any Exhibit hereto, the provisions in the body of this Agreement shall control, unless Exhibit E is attached to this Agreement.

<u>TYPE OF FUNDING</u>	<u>ATTACHED EXHIBITS</u>
<input type="checkbox"/> ESG CFDA #14.231 <input type="checkbox"/> ESG-State <input type="checkbox"/> CDBG CFDA #14.218 <input type="checkbox"/> Continuum of Care #14.267 <input type="checkbox"/> Community Services Fund <input type="checkbox"/> LMIHAF <input type="checkbox"/> County TOT <input type="checkbox"/> County R&R <input checked="" type="checkbox"/> <i>Program is fully funded with private funds; County will provide liability insurance and indemnify the State of California National Guard on behalf of St. Vincent de Paul-Sonoma.</i>	<input checked="" type="checkbox"/> EXHIBIT A-Scope of Services <input checked="" type="checkbox"/> EXHIBIT B-Budget <input checked="" type="checkbox"/> EXHIBIT C-Environmental <input checked="" type="checkbox"/> EXHIBIT D-HMIS <input type="checkbox"/> EXHIBIT E- Federal Funding Requirements <input checked="" type="checkbox"/> EXHIBIT F-Insurance Requirements for Public Service Programs <input type="checkbox"/> EXHIBIT G – Relevant Program Standard <input type="checkbox"/> EXHIBIT H- Partnership Data Sharing Agreement

3.2 Cooperation With COMMISSION. St. Vincent de Paul-Sonoma shall cooperate with COMMISSION staff in the performance of all work hereunder.

3.3. Performance Standard. St. Vincent de Paul-Sonoma shall perform all work hereunder in a manner consistent with the level of competency and standard of care normally observed by a person practicing in ST. VINCENT DE PAUL-SONOMA's profession. COMMISSION has relied upon the professional ability and training of St. Vincent de Paul-Sonoma as a material inducement to enter into this Agreement. St. Vincent de Paul-Sonoma hereby agrees to provide all services under this Agreement in accordance with generally accepted professional practices and standards of care, as well as the requirements of applicable federal, state and local laws, it being understood that acceptance of ST. VINCENT DE PAUL-SONOMA's work by COMMISSION shall not operate as a waiver or release. If COMMISSION determines that any of ST. VINCENT DE PAUL-SONOMA's work is not in accordance with such level of competency and standard of care, COMMISSION, in its sole discretion, shall have the right to do any or all of the following: (a) require St. Vincent de Paul-Sonoma to meet with COMMISSION to review the quality of the work and resolve matters of concern; (b) require St. Vincent de Paul-Sonoma to repeat the work at no additional charge until it is satisfactory; (c) terminate this Agreement pursuant to the provisions of Article 4; or (d) pursue any and all other remedies at law or in equity.

3.4. Assigned Personnel.

3.4.1. St. Vincent de Paul-Sonoma shall assign only competent personnel to perform work hereunder. In the event that at any time COMMISSION, in its sole discretion,

desires the removal of any person or persons assigned by St. Vincent de Paul-Sonoma to perform work hereunder, St. Vincent de Paul-Sonoma shall remove such person or persons immediately upon receiving written notice from COMMISSION.

3.4.2. Any and all persons identified in this Agreement or any exhibit hereto as the project manager, project team, or other professional performing work hereunder are deemed by COMMISSION to be key personnel whose services were a material inducement to COMMISSION to enter into this Agreement, and without whose services COMMISSION would not have entered into this Agreement. St. Vincent de Paul-Sonoma shall not remove, replace, substitute, or otherwise change any key personnel without the written notification to COMMISSION.

3.4.3. In the event that any of St. Vincent de Paul-Sonoma's personnel assigned to perform services under this Agreement become unavailable due to resignation, sickness or other factors outside of St. Vincent de Paul-Sonoma's control, St. Vincent de Paul-Sonoma shall be responsible for timely provision of adequately qualified replacements.

4. Payment: COMMISSION agrees to provide liability insurance and indemnification to the State of California, National Guard in the amounts as required by the license agreement. No funds will be paid to St. Vincent de Paul-Sonoma.

5. Method and Place of Giving Notice: All notices shall be made in writing and shall be given by personal delivery or by U.S. Mail or courier service. Notices, bills, and payments shall be addressed as follows:

COMMISSION:

Jenny Abramson, Homeless and Community Services Manager
Sonoma County Community Development Commission
1440 Guerneville Road
Santa Rosa, CA 95403

ST. VINCENT DE PAUL-SONOMA:

Jack Tibbetts, Executive Director
The Society of St. Vincent de Paul District Council of Sonoma County, Inc.
5671 Redwood Drive
Rohnert Park, CA 94928

When a notice is given by a generally recognized overnight courier service, the notice shall be deemed received on the next business day. When a copy of a notice is sent by facsimile or email, the notice shall be deemed received upon transmission as long as (1) the original copy of the notice is promptly deposited in the U.S. mail and postmarked on the date of the facsimile or email, (2) the sender has a written confirmation of the facsimile transmission or email, and (3) the facsimile or email is transmitted before 5 p.m. (local time). In all other instances, notices shall be effective upon receipt by the recipient. Changes may be made in the names and

addresses of the person to whom notices are to be given by giving notice pursuant to this paragraph.

6. Assignment and Delegation: Except as provided above, neither party hereto shall assign, sublet, or transfer any interest in or duty under, this Agreement without written consent of the other and no assignment shall be of any force or effect whatsoever unless and until the other party shall have so consented.

7. Ownership and Disclosure Of Work Product. All reports, original drawings, graphics, plans, studies, and other data or documents ("documents"), in whatever form or format, assembled or prepared by St. Vincent de Paul-Sonoma or St. Vincent de Paul-Sonoma's subcontractors, Agencies, and other agents in connection with this Agreement shall be the property of COMMISSION. COMMISSION shall be entitled to immediate possession of such documents upon completion of the work pursuant to this Agreement. Upon expiration or termination of this Agreement, St. Vincent de Paul-Sonoma shall promptly deliver to COMMISSION all such documents, which have not already been provided to COMMISSION in such form or format, as COMMISSION deems appropriate. Such documents shall be and will remain the property of COMMISSION without restriction or limitation. St. Vincent de Paul-Sonoma may retain copies of the above described documents but agrees not to disclose or discuss any information gathered, discovered, or generated in any way through this Agreement without the express written permission of COMMISSION.

8. Operational Changes: St. Vincent de Paul-Sonoma shall forward any material modifications to its program, policies, or procedures to COMMISSION.

9. Subcontracts: St. Vincent de Paul-Sonoma shall cause all of the provisions of this Agreement in its entirety to be included in and made a part of any subcontract executed in the performance of this Agreement. St. Vincent de Paul-Sonoma shall monitor all subcontracted services on a regular basis to ensure contract compliance. St. Vincent de Paul-Sonoma shall undertake to ensure that all subcontracts let in the performance of this Agreement are awarded on a fair and open competition basis. Executed copies of all subcontracts shall be forwarded to COMMISSION along with a summary description of the selection process.

10. Status of St. Vincent de Paul-Sonoma: The parties intend that St. Vincent de Paul-Sonoma, in performing the services herein specified, shall act as an independent contractor and shall have control of the work and the manner in which it is performed. St. Vincent de Paul-Sonoma is not to be considered an agent or employee of COMMISSION and is not entitled to participate in any pension plan, insurance, bonus, or similar benefits COMMISSION provides its employees.

11. Insurance: St. Vincent de Paul-Sonoma is required to maintain the insurance specified in Exhibit F, which is attached hereto and incorporated herein by this reference.

12. Indemnification: St. Vincent de Paul-Sonoma agrees to accept all responsibility for loss or damage to any person or entity, including but not limited to COMMISSION, and to defend, indemnify, hold harmless, reimburse and release COMMISSION, its officers, agents and employees from and against any and all actions, claims, damages, disabilities, liabilities and

expense, including but not limited to attorneys' fees and the cost of litigation incurred in the defense of claims as to which this indemnity applies or incurred in an action by COMMISSION to enforce the indemnity provisions herein, whether arising from personal injury, property damage or economic loss of any type, that may be asserted by any person or entity, including St. Vincent de Paul-Sonoma, arising out of or in connection with the performance of St. Vincent de Paul-Sonoma hereunder, whether or not there is concurrent negligence on the part of COMMISSION, but, to the extent required by law, excluding liability due to the sole or active negligence or due to the willful misconduct of COMMISSION. If there is a possible obligation to indemnify, St. Vincent de Paul-Sonoma's duty to defend exists regardless of whether it is ultimately determined that there is not a duty to indemnify. COMMISSION shall have the right to select its own legal counsel at the expense of St. Vincent de Paul-Sonoma, subject to St. Vincent de Paul-Sonoma's approval, which approval shall not be unreasonably withheld. This indemnification obligation is not limited in any way by any limitation on the amount or type of damages or compensation payable to or for St. Vincent de Paul-Sonoma or its agents under workers' compensation acts, disability benefits acts, or other employee benefit acts.

13. COMMISSION's Liaison Officer. The COMMISSION shall appoint a designated liaison officer. That officer shall have the authority to monitor the program and fiscal operations of the St. Vincent de Paul-Sonoma on behalf of the COMMISSION. St. Vincent de Paul-Sonoma shall appoint a representative to be available to the COMMISSION for consultation and assistance during the performance of this Agreement.

14. Prosecution of Work. The execution of this Agreement shall constitute St. Vincent de Paul-Sonoma's authority to proceed immediately with the performance of this Agreement. Performance of the services hereunder shall be completed within the time required herein, provided, however, that if the performance is delayed by earthquake, flood, high water, or other Act of God or by strike, lockout, or similar labor disturbances, the time for St. Vincent de Paul-Sonoma's performance of this Agreement shall be extended by a number of days equal to the number of days St. Vincent de Paul-Sonoma has been delayed.

15. Extra or Changed Work. Extra or changed work or other changes to the Agreement may be authorized only by written amendment to this Agreement, signed by both parties. Minor changes, which do not increase the amount paid under the Agreement, and which do not significantly change the scope of work or significantly lengthen time schedules may be executed by the Executive Director in a form approved by County Counsel. The Board of Commissioners and/or the Sonoma County Board of Supervisors must authorize all other extra or changed work. Failure of St. Vincent de Paul-Sonoma to secure such written authorization for extra or changed work shall constitute a waiver of any and all right to adjustment in the Agreement price or Agreement time due to such unauthorized work and thereafter St. Vincent de Paul-Sonoma shall be entitled to no compensation whatsoever for the performance of such work. St. Vincent de Paul-Sonoma further expressly waives any and all right or remedy by way of restitution and quantum merit for any and all extra work performed without such express and prior written authorization of the COMMISSION.

16. Demand for Assurance. Each party to this Agreement undertakes the obligation that the other's expectation of receiving due performance will not be impaired. When reasonable grounds for insecurity arise with respect to the performance of either party, the other may in writing demand adequate assurance of due performance and until such assurance is received may, if commercially reasonable, suspend any performance for which the agreed return has not been received. "Commercially reasonable" includes not only the conduct of a party with respect to performance under this Agreement, but also conduct with respect to other agreements with parties to this Agreement or others. After receipt of a justified demand, failure to provide within a reasonable time, but not exceeding thirty (30) days, such assurance of due performance as is adequate under the circumstances of the particular case is a repudiation of this Agreement. Acceptance of any improper delivery, service, or payment does not prejudice the aggrieved party's right to demand adequate assurance of future performance. Nothing in this Article limits COMMISSION's right to terminate this Agreement pursuant to Article 4.

17. Merger: This writing is intended both as the final expression of the Agreement between the parties hereto with respect to the included terms and as a complete and exclusive statement of the terms of the Agreement, pursuant to California Code of Civil Procedure § 1856.

No modification of this Agreement shall be effective unless and until such modification is evidenced by a writing signed by both parties.

18. Reporting: St. Vincent de Paul-Sonoma agrees to provide a written quarterly report ten (10) days after the end of each quarter. Each quarterly report shall describe the progress of the project.

Within ten (10) days after the termination date of this Agreement, St. Vincent de Paul-Sonoma agrees to submit to COMMISSION a final report that will address the accomplishments made during the operating period. All quarterly and final reports shall be submitted in a form specified by COMMISSION.

St. Vincent de Paul-Sonoma, if a non-profit California Corporation, agrees to submit minutes of their Board of Directors meetings to the COMMISSION, electronically or in hard copy, in a timely fashion.

19. Amendments: The COMMISSION or St. Vincent de Paul-Sonoma may amend this Agreement at any time providing that such amendments make specific reference to this Agreement, and are executed in writing, signed by duly authorized representatives of both organizations, and approved by the COMMISSION's governing body. Such amendments shall not invalidate this Agreement, nor relieve or release the COMMISSION or St. Vincent de Paul-Sonoma from its obligations under this Agreement.

The COMMISSION may, in its discretion, amend this Agreement to conform to federal, state or local governmental guidelines, policies, and changes in available funding amounts, or for other reasons. If such amendments result in a change in the scope of services, or schedule of the

activities to be undertaken as part of this Agreement, such modifications will be incorporated only by written amendment signed by both COMMISSION and St. Vincent de Paul-Sonoma.

20. Publicity: Any publicity generated by SUBRECIPIENT for the work performed pursuant to this Agreement, during the term of this Agreement or for one year thereafter, will make reference to the contribution of COMMISSION in making the project possible. The words "Sonoma County Community Development Commission" will be explicitly stated in any and all pieces of publicity, including but not limited to flyers, press releases, posters, brochures, public service announcements, interviews, and newspaper articles. The SUBRECIPIENT shall not comment publicly to the press or any other media regarding data, countywide initiatives, or related actions without the knowledge and consent of the COMMISSION. The SUBRECIPIENT shall not issue any news release, make claims regarding data related to work performed, or services performed under this contract or through the COMMISSION without prior review of the contents thereof.

21. Representations of St. Vincent de Paul-Sonoma.

21.1 Status of St. Vincent de Paul-Sonoma. As noted in paragraph 10, St. Vincent de Paul-Sonoma is not to be considered an agent or employee of COMMISSION and is not entitled to participate in any pension plan, worker's compensation plan, insurance, bonus, or similar benefits COMMISSION provides its employees. In the event COMMISSION exercises its right to terminate this Agreement pursuant to Article 2, above, St. Vincent de Paul-Sonoma expressly agrees that it shall have no recourse or right of appeal under rules, regulations, ordinances, or laws applicable to employees.

21.2 Taxes. St. Vincent de Paul-Sonoma agrees to file federal and state tax returns and pay all applicable taxes on amounts paid pursuant to this Agreement and shall be solely liable and responsible to pay such taxes and other obligations, including, but not limited to, state and federal income and FICA taxes. St. Vincent de Paul-Sonoma agrees to indemnify and hold COMMISSION harmless from any liability which it may incur to the United States or to the State of California as a consequence of ST. VINCENT DE PAUL-SONOMA's failure to pay, when due, all such taxes and obligations. In case COMMISSION is audited for compliance regarding any withholding or other applicable taxes, St. Vincent de Paul-Sonoma agrees to furnish COMMISSION with proof of payment of taxes on these earnings.

21.3 Records Maintenance. St. Vincent de Paul-Sonoma shall keep and maintain full and complete documentation and accounting records concerning all services performed that are compensable under this Agreement and shall make such documents and records available to COMMISSION for inspection at any reasonable time. St. Vincent de Paul-Sonoma shall maintain such records for a period of five (5) years following completion of work hereunder.

21.4 Conflict of Interest. St. Vincent de Paul-Sonoma covenants that it presently has no interest and that it will not acquire any interest, direct or indirect, that represents a financial conflict of interest under state law or that would otherwise conflict in any manner or degree with the performance of its services hereunder. St. Vincent de Paul-Sonoma further covenants that in the

performance of this Agreement no person having any such interests shall be employed. In addition, if requested to do so by COMMISSION, St. Vincent de Paul-Sonoma shall complete and file and shall require any other person doing work under this Agreement to complete and file a "Statement of Economic Interest" with COMMISSION disclosing St. Vincent de Paul-Sonoma's or such other person's financial interests.

21.5 Statutory Compliance. St. Vincent de Paul-Sonoma agrees to comply with all applicable federal, state and local laws, regulations, statutes and policies applicable to the services provided under this Agreement as they exist now and as they are changed, amended or modified during the term of this Agreement.

21.6 Nondiscrimination. Without limiting any other provision hereunder, St. Vincent de Paul-Sonoma shall comply with all applicable federal, state, and local laws, rules, and regulations in regard to nondiscrimination in employment because of race, color, ancestry, national origin, religion, sex, marital status, age, medical condition, pregnancy, disability, sexual orientation or other prohibited basis, including without limitation, the County's Non-Discrimination Policy. All nondiscrimination rules or regulations required by law to be included in this Agreement are incorporated herein by this reference.

21.7 AIDS Discrimination. St. Vincent de Paul-Sonoma agrees to comply with the provisions of Chapter 19, Article II, of the Sonoma County Code prohibiting discrimination in housing, employment, and services because of AIDS or HIV infection during the term of this Agreement and any extensions of the term.

21.8 Living Wage Requirements. St. Vincent de Paul-Sonoma shall comply with any and all federal, state, and local laws – including, but not limited to the County of Sonoma Living Wage Ordinance – affecting the services provided by this contract. Without limiting the generality of the foregoing, St. Vincent de Paul-Sonoma expressly acknowledges and agrees that this contract is subject to the provisions of Article XXVI of Chapter 2 of the Sonoma County Code, requiring payment of a living wage to covered employees. Noncompliance during the term of the Operating Agreement will be considered a material breach and may result in termination of the Operating Agreement or pursuit of other legal or administrative remedies.

21.9 Assignment of Rights. St. Vincent de Paul-Sonoma assigns to COMMISSION all rights throughout the world in perpetuity in the nature of copyright, trademark, patent, right to ideas, in and to all versions of the plans and specifications, if any, now or later prepared by St. Vincent de Paul-Sonoma in connection with this Agreement. St. Vincent de Paul-Sonoma agrees to take such actions as are necessary to protect the rights assigned to COMMISSION in this Agreement, and to refrain from taking any action which would impair those rights. St. Vincent de Paul-Sonoma's responsibilities under this provision include, but are not limited to, placing proper notice of copyright on all versions of the plans and specifications as COMMISSION may direct, and refraining from disclosing any versions of the plans and specifications to any third party without first obtaining written permission of COMMISSION. St. Vincent de Paul-Sonoma shall not use or permit another to use the plans and specifications in connection with this or any other project without first obtaining written permission of COMMISSION.

21.10 Authority. The undersigned hereby represents and warrants that he or she has authority to execute and deliver this Agreement on behalf of St. Vincent de Paul-Sonoma.

22. Miscellaneous Provisions.

22.1 No Waiver of Breach. The waiver by COMMISSION of any breach of any term or promise contained in this Agreement shall not be deemed to be a waiver of such term or provision or any subsequent breach of the same or any other term or promise contained in this Agreement.

22.2 Construction. To the fullest extent allowed by law, the provisions of this Agreement shall be construed and given effect in a manner that avoids any violation of statute, ordinance, regulation, or law. The parties covenant and agree that in the event that any provision of this Agreement is held by a court of competent jurisdiction to be invalid, void, or unenforceable, the remainder of the provisions hereof shall remain in full force and effect and shall in no way be affected, impaired, or invalidated thereby. St. Vincent de Paul-Sonoma and COMMISSION acknowledge that they have each contributed to the making of this Agreement and that, in the event of a dispute over the interpretation of this Agreement, the language of the Agreement will not be construed against one party in favor of the other. St. Vincent de Paul-Sonoma and COMMISSION acknowledge that they have each had an adequate opportunity to consult with counsel in the negotiation and preparation of this Agreement.

22.3 Consent. Wherever in this Agreement the consent or approval of one party is required to an act of the other party, such consent or approval shall not be unreasonably withheld or delayed.

22.4 No Third Party Beneficiaries. Nothing contained in this Agreement shall be construed to create and the parties do not intend to create any rights in third parties.

22.5 Applicable Law and Forum. This Agreement shall be construed and interpreted according to the substantive law of California, regardless of the law of conflicts to the contrary in any jurisdiction. Any action to enforce the terms of this Agreement or for the breach thereof shall be brought and tried in Santa Rosa or the forum nearest to the city of Santa Rosa, in the County of Sonoma.

22.6 Captions. The captions in this Agreement are solely for convenience of reference. They are not a part of this Agreement and shall have no effect on its construction or interpretation.

22.7 Merger. This writing is intended both as the final expression of the Agreement between the parties hereto with respect to the included terms and as a complete and exclusive statement of the terms of the Agreement, pursuant to Code of Civil Procedure Section 1856. No modification of this Agreement shall be effective unless and until such modification is evidenced by a writing signed by both parties.

22.8 Survival of Terms. All express representations, waivers, indemnifications, and limitations of liability included in this Agreement will survive its completion or termination for any reason.

22.9 Time of Essence. Time is and shall be of the essence of this Agreement and every provision hereof.

IN WITNESS WHEREOF, the parties hereto have executed this instrument or caused this Agreement to be executed by their duly authorized agents this _____ day of _____, 2018.

SONOMA COUNTY COMMUNITY
DEVELOPMENT COMMISSION

By:

Margaret Van Vliet, Executive Director

THE SOCIETY OF ST. VINCENT DE PAUL DISTRICT
COUNCIL OF SONOMA COUNTY, INC.

By:

Jack Tibbetts, Executive Director

EXHIBIT A
SCOPE OF WORK

1. Services to be Provided

1.1 St. Vincent de Paul-Sonoma Duties

1.1.1. St. Vincent de Paul-Sonoma shall provide services defined and set forth in Exhibit A-I attached hereto and incorporated by this reference.

1.1.2. St. Vincent de Paul-Sonoma shall provide all necessary qualified personnel for performance of services under this Agreement.

1.1.3. St. Vincent de Paul-Sonoma shall record services and submit reports as required by COMMISSION, enumerating all services delivered to clients. St. Vincent de Paul-Sonoma shall make available to COMMISSION all records necessary to conduct thorough and comprehensive contract monitoring and auditing, and to conduct research and evaluation concerning St. Vincent de Paul-Sonoma and project as appropriate under terms of this Agreement.

1.1.4 St. Vincent de Paul-Sonoma agrees to provide a written quarterly report ten (10) days after the end of each quarter. Each quarterly report shall describe the progress of the project. Within ten (10) days after the termination date of this Agreement, St. Vincent de Paul-Sonoma agrees to submit to COMMISSION a final report that will address the accomplishments made during the Operating period. All quarterly and final reports shall be submitted in a form specified by COMMISSION. St. Vincent de Paul-Sonoma, if a non-profit California Corporation, agrees to submit minutes of their Board of Directors meetings to the COMMISSION, electronically or in hard copy, in a timely fashion.

**EXHIBIT A-1
SCOPE OF WORK**

Organizational Name: The Society of St. Vincent de Paul District Council of Sonoma County, Inc.

Program Name: **Armory Winter Shelter**

The Sonoma County Community Development Commission (SCCDC) will act as lessee and provide required liability insurance and indemnification to the State of California National Guard, to allow The Society of St. Vincent de Paul, District Council of Sonoma, Inc. to operate the **Armory Winter Shelter**, located at **1500 Armory Drive, Santa Rosa 95401**. The Armory Winter Shelter program will provide overnight emergency shelter to homeless persons in Sonoma County from November 19th, 2018 to March 3rd, 2019. The project will measure one outcome: the number of participants who utilize the Armory Winter Shelter program.

Shelter services will include overnight accommodations for up to 80 persons nightly, and support to identify further service needs and opportunities and referrals to housing opportunities. Participants will have access to other services as needed.

Armory Winter Shelter staff will input client data into the Homeless Management Information System (HMIS), following all relevant data quality standards, and will refer all participants to appropriate County, State, and local services. The Society of St. Vincent de Paul, District Council of Sonoma, Inc. will participate in technical assistance to develop and increase their capacity to deliver services using a Housing First approach. The Society of St. Vincent de Paul, District Council of Sonoma, Inc. will adhere to the Sonoma County Continuum of Care Emergency Shelter Program Standards as the minimum operational standards for emergency and winter shelters.

The number of individuals and households, income demographics, ethnicity, outcome performance, changes in staffing, and anecdotal descriptions of services provided at the Armory Winter Shelter will be reported quarterly using the prescribed reporting form.

This agreement will begin on December 22, 2017, and will expire on March 31, 2018.

Estimated Unduplicated Numbers to be served by the project:

210	Households
210	Adults
	Children

HMIS Participation

Required Project will be HMIS Service Only setup Not Applicable

- Participant Demographics, Program Entry, Rental Assistance Assessments, Debt Reduction and Sono – Homeless Participant and Rental Assistance TouchPoints

Project Title in HMIS: **SVdP – Sonoma Armory Winter Shelter**

If HMIS is Not Applicable, source of data for reporting [Click here to enter text.](#)
 Non-HMIS documentation to be submitted quarterly:

[Click here to enter text.](#)

Verification of Homeless and Documentation Requirements per HUD Homeless Status Definition Final Rule, December 5, 2011, CFR Parts 91, 582 and 583:

Required Not Applicable

Verification of Chronic Homelessness Status per HUD Chronically Homeless Definition Final Rule, December 4, 2016, 24 CFR Parts 91 and 578:

Required Not Applicable

Verification of At-Risk of Homelessness and Documentation Requirements per ESG Interim Rule, December 5, 2012, CFR Parts 91, 582 and 583:

Required Not Applicable

Coordinated Intake Participation

Required Not Applicable (Participants will not meet Homelessness definitions #1 or #2)

Participation in Continuum of Care Program Standards Development and Review

Required Not Applicable Emergency Shelter Standards

The project is be required to adhere to the Emergency Shelter Standards, but is not required to participate in standards development.

Reporting Requirements:

St. Vincent de Paul-Sonoma shall report quarterly on approved COMMISSION formatted template the following data:

1. Unduplicated Individuals and or Households served during the reporting period
2. Race, Ethnicity and Income levels
3. ESG CAPER data entered and meeting data standards
4. Status on the following CDC approved Outcomes

Outcome Number	Outcome Area	Performance Measure or Outcome Indicator Select an Outcome Indicator that you will measure your success against	Project Goal Briefly describe how your project will work towards achievement the specified Outcome Indicator	Quantitative Measure Identify a numerical increase or decrease for the specified Outcome Indicator
1	Targeted Factor 10-Year Homeless Action Plan / Hearth Performance Measures	HEARTH / 10 Year Homeless Action Plan Indicators Placement of unsheltered in safe housing	Utilization of Armory Shelter resources by unsheltered persons	100 % or of 210

EXHIBIT B
FISCAL PROVISIONS AND BUDGET

1. Fiscal Responsibilities. In consideration of the obligations to be performed by St. Vincent de Paul-Sonoma herein, St. Vincent de Paul-Sonoma shall not be reimbursed for its costs, but COMMISSION will provide liability insurance and indemnification meeting the requirements of the State's license agreement with the County of Sonoma.

1.2. No Supplantation. St. Vincent de Paul-Sonoma must not claim reimbursement under this Agreement for expenditures reimbursed or financed by any other private or federal, state, or local government source. No supplantation of program financing by St. Vincent de Paul-Sonoma is contemplated or allowed.

1.3. Indirect Cost Rate. St. Vincent de Paul-Sonoma is responsible for providing an approved Indirect Cost Rate in accordance with 2 CFR Part 200, Uniform Administrative Requirements, Cost Principles, and Audit Requirements for Federal Awards, for the Agreement year, when claiming indirect and/or administrative costs under this Agreement.

1.3.1. St. Vincent de Paul-Sonoma must submit an Indirect Cost Rate Proposal to COMMISSION for approval within thirty (30) days following execution of this Agreement unless St. Vincent de Paul-Sonoma has a current negotiated rate letter with another St. Vincent de Paul-Sonoma. In such case, St. Vincent de Paul-Sonoma must provide a copy of the negotiated rate letter within the above timeframe.

1.3.2. Indirect and/or administrative costs intended to be claimed under this Agreement will not be reimbursed without an approved Indirect Cost Rate or the provision of St. Vincent de Paul-Sonoma's cost allocation plan for the Agreement year.

1.4 Financial Records. St. Vincent de Paul-Sonoma understands and accepts its obligation to establish and maintain records of all program expenditures.

1.4.1. St. Vincent de Paul-Sonoma shall make available for inspection and audit to representatives of COMMISSION, county, federal, and/or state governments all books, financial records, program information, and other records pertaining to the overall operation of St. Vincent de Paul-Sonoma and this Agreement, and shall allow said representatives to review and inspect its facilities and program operation of this Agreement to assure compliance with all applicable local, state, and/or federal regulations. St. Vincent de Paul-Sonoma shall maintain the accounting records in conformity with generally accepted accounting principles and as directed by COMMISSION.

1.4.2. If it should be determined during the term of this Agreement by the COMMISSION and/or Board of Commissioners that funds are not being utilized by St. Vincent de Paul-Sonoma in accordance with this Agreement, an audit may be ordered of St. Vincent de Paul-Sonoma's books, financial records, and program records. The cost of this audit shall be deducted from the total paid to St. Vincent de Paul-Sonoma through this Agreement.

1.4.3. In the event that St. Vincent de Paul-Sonoma terminates its business activities, all records related to this Agreement shall be promptly delivered to COMMISSION by St. Vincent de Paul-Sonoma. St. Vincent de Paul-Sonoma shall be liable for any and all attorneys' fees incurred by COMMISSION in recovering records pursuant to this section.

1.5 Procurement. No procurement is authorized which is not specifically identified and approved herein. No equipment or capital projects are to be financed with this grant.

1.6. Funding Contingency. Notwithstanding anything contained in the Agreement to the contrary, St. Vincent de Paul-Sonoma acknowledges that any payments to be made to it as provided herein shall be expressly contingent upon the receipt of sufficient funds by COMMISSION.

2. Transfer of Program Funds/Budget Adjustments, The Community Development Commission Executive Director or designee is authorized to approve and execute the transfer of funds between cost categories set forth in Exhibit B-1, and to approve and execute other changes to the Agreement, so long as such changes do not result in a significant change to the program design or an increase in COMMISSION'S maximum financial obligation as set forth in Section 4 of this Agreement. COMMISSION'S written approval is required prior to the transfer of any program funds between cost categories set forth in the Exhibit B-1.

3. Closeout. Final reimbursement request is due within five (5) days of fiscal year end.

4. Repayment. St. Vincent de Paul-Sonoma is responsible for the repayment of all audit exceptions and disallowances taken by COMMISSION, county, state, or federal agencies related to activities conducted by St. Vincent de Paul-Sonoma under this Agreement.

EXHIBIT B-1
Budget

The Society of St. Vincent de Paul District Council of Sonoma County, Inc.
Armory Winter Shelter

The Armory Winter Shelter will be operated solely with the funding that St. Vincent de Paul – Sonoma has raised for this purpose. No funding will be provided by the Commission or the County of Sonoma to operate the Armory Winter Shelter.

St. Vincent de Paul – Sonoma will be responsible for all expenses to the Commission or the County of Sonoma, such as rental fees and any other fees required by the State of California National Guard.

The Commission will provide liability insurance and indemnification meeting the requirements of the State’s license agreement with the County of Sonoma.

EXHIBIT C
Environmental Standards

NEPA

Review by COMMISSION staff indicates that the project has an environmental review status of Categorically Excluded. COMMISSION staff has prepared all documentation required by HUD.

CEQA

Project activity not subject to CEQA review.

EXHIBIT D
Homeless Management Information System (HMIS)

As stated more specifically in the Sonoma County Continuum of Care Homeless Management Information System Participant Agreement, St. Vincent de Paul-Sonoma must be in “good standing” in collecting and entering current, accurate, and comprehensive data that reflects the homeless program services delivered by St. Vincent de Paul-Sonoma into the COMMISSION’s Efforts to Outcomes (EtO) Homeless Management Information System (HMIS) licensed by Social Solutions Group as a condition of this Agreement.

A. HMIS “Good Standing”: Good Standing is defined as timely data entry, complete and accurate data reflective of the Participant status at Intake, Update and Exit and as defined by the prevailing HMIS Data Standards.

1. Timely data entry:

a. Unless otherwise approved in writing and attached to this agreement, entry of data into EtO HMIS within five (5) business days of the event that generated by the data collection (i.e., Participant Intake, Entry and Exit from Program, and required annual updates if Participant is participating for longer than one year in the program).

2. Accurate and Complete Data:

a. All homeless Participant data for Covered Homeless Organizations (CHO’s) will be entered into the EtO HMIS unless approved in writing and attached to this agreement.

b. 95% of all HUD or Sonoma County defined mandated data points are supplied (fields do NOT reflect a “Null”, “Don’t Know or Refused” OR “Data Not Collected” value).

c. The EtO Data Validation (DVE) reports (required Quarterly Reporting for each homeless program) will reflect a 95% or higher data completeness and quality result at all times.

3. Data Collection Methodology:

a. St. Vincent de Paul-Sonoma shall adhere to the most current HMIS Data Standards and Sonoma County HMIS Lead designed program workflow(s) for each homeless program type.

B. User Training: All Users of the HMIS will receive general HMIS User Training and Security and Ethics prior to receiving login credentials to the HMIS. Additionally, all HMIS Users shall receive updated Security and Ethics training annually. **St. Vincent de Paul-Sonoma shall report Users departing their HMIS role for any reason within 24 hours of their departure for removal of user from the EtO HMIS.**

- C. Required Quarterly Reporting: St. Vincent de Paul-Sonoma shall utilize data from the following reports as the basis for quarterly report submissions and include with their report submission:
- a. EtO Data Validation (DVE) report for the program being reported with a data range from the start of the fiscal year to the end of the required report period (cumulative)
 - b. The 1-Sono – 0607-CDBG/CAPER (CDC Quarterly & Other Grant Reporting)
- D. HMIS Financial Match and Other Financial Requirement: St. Vincent de Paul-Sonoma agrees to pay the calculated fair share portion of the McKinney-Vento required funding match within 60 days of billing by the Commission. St. Vincent de Paul-Sonoma also agrees to provide the Commission with leveraging information within 30 days of request.
- E. Homeless Count Participation: St. Vincent de Paul-Sonoma will take part in annual sheltered Homeless Count by maintaining accurate and up-to-date data in good standing and being responsive to the Continuum of Care and HMIS Coordinators' requests for current and accurate information. St. Vincent de Paul-Sonoma will take part in the annual unsheltered Homeless Count by assigning staff to assist in the Count process and by making facilities and other St. Vincent de Paul-Sonoma resources available to support the Count commensurate to the size of the St. Vincent de Paul-Sonoma's homelessness program relative to the overall Sonoma County Continuum of Care program.
- F. Sonoma County Homeless Coordinated Intake Participation: St. Vincent de Paul-Sonoma shall agree to participate in the CI system by referring homeless participants directly to CI for intake, communicating with the CI operator. St. Vincent de Paul-Sonoma about program referral placement and/or reasons for declining participants. Determination of participant referrals will be completed within a timely manner of ten business days or less.

Exhibit F
Insurance Requirements for Public Service Programs

SUBRECIPIENT shall maintain insurance as described below unless such insurance has been expressly waived by the attachment of a *Waiver of Insurance Requirements*. The insurance shall be maintained for FISCAL YEAR 2018-2019 after all funds have been disbursed.

COMMISSION reserves the right to review any and all of the required insurance policies and/or endorsements, but has no obligation to do so. **COMMISSION'S** failure to demand evidence of full compliance with the insurance requirements set forth in this Agreement or **Commission's** failure to identify any insurance deficiency shall not relieve **SUBRECIPIENT** from, nor be construed or deemed a waiver of, its obligation to maintain the required insurance at all times during the performance of this Agreement.

1. Workers Compensation and Employers Liability Insurance

- a. Required if **SUBRECIPIENT** has employees as defined by the Labor Code of the State of California.
- b. Workers Compensation insurance with statutory limits as required by the Labor Code of the State of California.
- c. Employers Liability with minimum limits of \$1,000,000 per Accident; \$1,000,000 Disease per employee; \$1,000,000 Disease per policy.
- d. Required Evidence of Insurance: Certificate of Insurance.

If **SUBRECIPIENT** currently has no employees as defined by the Labor Code of the State of California, **SUBRECIPIENT** agrees to obtain the above-specified Workers Compensation and Employers Liability insurance should employees be engaged during the term of this Agreement or any extensions of the term.

2. General Liability Insurance

- a. Commercial General Liability Insurance on a standard occurrence form, no less broad than Insurance Services Office (ISO) form CG 00 01.
- b. Minimum Limits: \$1,000,000 per Occurrence; \$2,000,000 General Aggregate; \$2,000,000 Products/Completed Operations Aggregate. The required limits may be provided by a combination of General Liability Insurance and either Commercial Excess or Commercial Umbrella Liability Insurance. If **SUBRECIPIENT** maintains higher limits than the specified minimum limits, County requires and shall be entitled to coverage for the higher limits maintained by **SUBRECIPIENT**.
- c. Any deductible or self-insured retention shall be shown on the Certificate of Insurance. If the deductible or self-insured retention exceeds \$25,000 it must be approved in advance by **COMMISSION**. **SUBRECIPIENT** is responsible for any deductible or self-insured retention and shall fund it upon **COMMISSION'S** written request, regardless of whether **SUBRECIPIENT** has a claim against the insurance or is named as a party in any action involving the County.
- d. Sonoma County Economic Development Board and the County of Sonoma, their officers, agents and employees, 1440 Guerneville Rd, Santa Rosa, CA 95403 shall be endorsed as

additional insureds for liability arising out of **SUBRECIPIENT'S** ongoing operations. (ISO endorsement CG 20 26 or equivalent).

- e. The insurance provided to the additional insureds shall be primary to, and non-contributory with, any insurance or self-insurance program maintained by them.
- f. The policy definition of "insured contract" shall include assumptions of liability arising out of both ongoing operations and the products-completed operations hazard (broad form contractual liability coverage including the "f" definition of insured contract in ISO form CG 00 01, or equivalent).
- g. The policy shall cover inter-insured suits between **COMMISSION** and **SUBRECIPIENT** and include a "separation of insureds" or "severability" clause which treats each insured separately.
- h. **Required Evidence of Insurance:**
 - i. Copy of the additional insured endorsement or policy language granting additional insured status; and
 - ii. Certificate of Insurance.

3. **Automobile Liability Insurance**

- a. Minimum Limit: \$1,000,000 combined single limit per accident. The required limit may be satisfied by a combination of Automobile Liability Insurance and either Commercial Excess or Commercial Umbrella Liability Insurance.
- b. Insurance shall cover all owned vehicles if **SUBRECIPIENT** owns vehicles.
- c. Insurance shall cover hired and non-owned vehicles.
- d. **Required Evidence of Insurance:** Certificate of Insurance.

4. **Professional Liability/Errors and Omissions Insurance** (*Only required of recipients whose normal operations include professional services.*)

- a. Minimum Limit: \$1,000,000 per claim or per occurrence.
- b. Any deductible or self-insured retention shall be shown on the Certificate of Insurance. If the deductible or self-insured retention exceeds \$25,000 it must be approved in advance by County.
- c. If the insurance is on a Claims-Made basis, the retroactive date shall be no later than the commencement of the work.
- d. **Required Evidence of Insurance:** Certificate of Insurance.

5. **Standards for Insurance Companies**

Insurers, other than the California State Compensation Insurance Fund, shall have an A.M. Best's rating of at least A:VII.

6. **Documentation**

- a. The Certificate of Insurance must include the following reference: **Homeless Services Center.**
- b. **SUBRECIPIENT** shall submit required Evidence of Insurance prior to the execution of this Agreement. **SUBRECIPIENT** agrees to maintain current Evidence of Insurance on file with County for the required period of insurance.
- c. The name and address for Additional Insured endorsements and Certificates of Insurance is: **Sonoma County Community Development Commission 1440 GUERNEVILLE**

RD, SANTA ROSA CA, 95403 .

- d. Required Evidence of Insurance shall be submitted for any renewal or replacement of a policy that already exists, at least ten (10) days before expiration or other termination of the existing policy.
- e. **SUBRECIPIENT** shall provide immediate written notice if: (1) any of the required insurance policies are terminated; (2) the limits of any of the required policies are reduced; or (3) the deductible or self-insured retention is increased.
- f. Upon written request, certified copies of required insurance policies must be provided within thirty (30) days.

7. Policy Obligations

SUBRECIPIENT'S indemnity and other obligations shall not be limited by the foregoing insurance requirements.

Santa Rosa Armory Temporary Winter Shelter

Operations Handbook

In Honor of Bob Solak and LeRoy Halbur

FACILITY

The Santa Rosa Armory Winter Shelter will serve a maximum participant population of 110 clients. The Shelter will be staffed from 5:00 pm to 8:30 am every day. Participants have access to free dinner and sleeping mats every night. Showers will be available from 5:30 pm to 7:30 pm daily.

SAFETY/HEALTH

Rules and guidelines for the shelter have been established to ensure the safety of all clients participating in the program. Clients agree to the following guidelines when entering the program:

- Curfew is 10:00 pm daily. Weapons, illegal drugs, alcohol are not permitted at the facility;
- Smoking is permitted outside in a designated area only;
- Violence or the threat of violent behavior is not permitted;
- Any form of harassment is not permitted;
- Theft or any other illegal activity is strictly prohibited at the facility;
- Donated items that are given directly to a participant become the property of the participant;

OPERATIONS: PERSONAL PROPERTY & STORAGE

The Santa Rosa Armory Shelter assumes no responsibility for oversight of a client's personal belongings. During their participation in the Winter Evening Shelter program, clients may store a limited number of personal belongings in and around their bed area. The Santa Rosa Armory Shelter is not responsible for lost or stolen items.

Clients should always take valuables and cash with them. Clients exiting the shelter must remove their personal belongings when leaving. The shelter is not responsible for lost or stolen items left behind after the client leaves the shelter. The following is a list of items that cannot be brought into the facility. This list is not inclusive of all banned items.

- No illegal drugs or alcohol;
- Flammable liquids or hazardous substances;
- Firearms, ammunition or knives.

Bringing any of these items into the facility is considered a serious incident and may lead to immediate termination from the program staff and administrators.

TRANSPORTATION PROTOCOL

Entry to the Santa Rosa Armory will begin at 6:30 pm. Guests arriving prior to 6:30 will be asked to leave and to return at 6:30 pm.

DENIAL OF SERVICE/GRIEVANCE

It is the policy of St. Vincent de Paul (SVdP) that persons served or seeking services have the right to voice their complaint, concern or formal grievance, if dissatisfied with decisions regarding treatment, services provided or experience with programs of SVdP. Upon request, clients will be given a grievance document, which will be submitted to the Shelter Supervisor and Executive Director.

INCIDENT REPORTS

Staff will complete incident reports for any medical, criminal or disaster-related incidents or emergencies. The purpose of the incident report is to document any observed or alleged criminal activity or other breach of SVdP policy, and to monitor the frequency of Santa Rosa Armory Winter Shelter disturbances. Clients will be warned and notified of their incident documentation and are privileged to review their own incident reports at any time. Incident reports are only to be completed by staff and will be saved in the client's confidential file. Notify the attending supervisor for instruction.

HOSPITALIZATIONS/INCARCERATIONS

If clients become hospitalized or incarcerated during their participation in the program, their status will be reviewed by staff, and a determination made.

SERVICE ANIMAL POLICY

Per ADA regulation, registered service animals are permitted in the Santa Rosa Winter Shelter.

MEDICAL PROTOCOL

Clients of the Santa Rosa Winter Shelter may be taking prescription medications. Clients are encouraged to follow their doctor's medical advice for medication administration, and are not allowed to sell or distribute prescriptions or medical supplies at the shelter.

BED BUG POLICY

Clients with bed bug infestations will not be admitted to the shelter. Similar parasites (such as lice and scabies) are also included in this policy. Clients will not be allowed to return until they are able to provide medical documentation that they are free from parasites. Their associated property must be cleaned and infestation-free before it's allowed in the Shelter.

CLIENT PRIVACY & INFORMATION SECURITY

Staff members are responsible for safeguarding all confidential client information. Any documented information (such as HMIS forms and incident reports) will be stored in a locked client file in the custody of the Service Navigator. Access to confidential information among staff is on a "need-to know" basis and must be authorized by supervising staff. Any breach of this policy will not be tolerated.

STAFF RESPONSIBILITIES

Shelter Program Supervisor

Responsibilities related to the Winter Evening Shelter include recruiting, training and supervising the Assistant Shelter Supervisor, Shelter Coordinators, and volunteers. This position provides direction and oversight for the shelter including volunteers, staff, and community involvement, as well as direction and oversight for HMIS data entry, upkeep and maintenance.

The Shelter Supervisor ensures shelter needs are met by purchasing and coordinating goods and services necessary to run the shelter, with approval of this budget by the Executive Director. This may include, but is not limited to food, cleaning supplies, bedding, and other necessities.

Service Navigator

The Service Navigator reports to the Executive Director, reviews client records and HMIS data, and is solely charged with coordinating with other service providers to help individuals secure permanent housing. The Service Navigator also provides appropriate referrals and case management to address client needs, such as applying for benefits and public assistance.

Assistant Shelter Supervisor

The Assistant Shelter Supervisor reports to the Shelter Supervisor. The Assistant Shelter Supervisor provides oversight of general operations, i.e. opening and closing, client issues, volunteers, speaking with clients, and our relationship with National Guard personnel.

The Assistant Supervisor has oversight of the Coordinators and volunteers, and may assign duties as such; however, scheduling and training should be completed by the Shelter Supervisor.

Shelter Coordinator

The Shelter Coordinator reports to the Shelter Supervisor and Assistant Shelter Supervisor. The Shelter Coordinator provides oversight in collaboration with the Shelter Supervisor and Assistant Shelter Supervisor. This position also carries out assigned duties, such as janitorial services, and monitors the clients for the safety and security of the facility.

Shelter Volunteers

The Shelter Coordinators and Volunteer Coordinator report to the Shelter Supervisor and Assistant Shelter Supervisor.

This position provides support to the shelter facilities through assigned duties.

SHELTER DUTIES AS ASSIGNED

Time	Activity	Staff
6:00 PM – 6:30 PM	Setup & Opening	Supervisor/Assistant Supervisor
6:30 PM – 10:30 PM	Security	SOCO Private Security
6:30 PM – 8:30 PM	Showers	Shelter Coordinator
6:30 PM – 9:30 PM	General Activity	Supervisor/Asst. Supervisor, Shelter Coordinator/Security.
7:00 PM – 8:00 PM	Light Dinner Served	Shelter Coordinator
9:30 PM – 6:00 AM	Lights Out/No Admittance	Assistant Supervisor/Shelter Coordinator/Security
10:30 PM	Security Shift Completed	Security
5:30 AM – 6:30 AM	Janitorial Services	Janitor, Shelter Coordinator to assist.
5:30 AM	Light On, guests served coffee and a pastry	Supervisor/Asst. Supervisor/Coordinator/Janitor/Volunteers
6:30 AM	Vacate Armory for Daily Operations	

NATIONAL GUARD

There are two National Guard representatives on duty from 6:30 pm to 6:30 am, Monday-Sunday at the Santa Rosa Armory. The National Guard representatives act as a key holder to the facility, gatekeeper to the back gate for an emergency evacuation, and ensures the armory is cleaned and properly maintained after the shelter program closes at 6:30 am. Any incidents will be reported to the Santa Rosa Police Department and to the National Guard representatives immediately, per the National Guard reporting requirements. A detailed daily count of all shelter clients will be provided to the National Guard representatives and emailed to the Service Navigator by noon the next day. SVDP Staff shall always respect the wishes of the National Guard and work to address and accommodate their questions and concerns. National Guard Soldiers or their representatives are encouraged to file any grievance with the Shelter Supervisor and Executive Director for any reason. SVDP Management will work within reason to accommodate the wishes, safety, and concerns of our hosts, and will always work to a mutually-beneficial outcome.

CHECK-IN PROCESS

Clients will enter through the front door and be contacted by two to three staff members/volunteers at the check-in table.

PERSONAL PROPERTY AND STORAGE

Clients may store some personal items near their sleeping pad so long as it does not impede the ingress and egress of other clients.

MEDICATIONS

All medications must be checked in at the front desk at intake and will be stored in the medications box. Medication will be returned to the client to take medication and then checked back in to the staff. Medications will be returned to the client when they leave in the morning. Medications will be logged and all logs will have initials of the client and a staff member upon entry and leaving in the morning.

BLANKETS

Some sleeping bags and blankets will be stored onsite.

SHOWERS

Showers are offered from 6:30 PM to 8:30 PM every night.

MEALS

A light dinner will be provided at the shelter. No trash, coffee cups, or food wrappers shall leave the premise with the individual.

ELECTRONICS

Shelter clients are authorized to use their own electronic devices within an authorized time frame. Any use of electronics after 9:00 pm must be silent (ear phones / ear buds are mandatory). Electronic devices may be charged in the shelter electrical outlets, as outlets are available.

LIGHTS OUT

Lights out and doors are locked at 9:00 pm.

SMOKING

Smoking is permitted only in designated outside areas, during designated hours. Shelter staff and volunteers will not sell, loan, or provide cigarettes to clients, nor buy, borrow, or accept cigarettes from clients.

DRUG AND ALCOHOL

Drugs, alcohol and related paraphernalia are prohibited at the shelter. This includes the outside perimeter, as well as the parking lot.

SEXUAL ACTIVITY

Sexual activity will not be allowed at the Winter Shelter. This includes the outside perimeter as well as the parking lot.

CONFLICT

If conflict occurs between one or more clients, mediation and conflict resolution may be available and is encouraged whenever possible. If the clients cannot become respectful of each other, one or all clients involved will be asked to leave. If the situation continues to escalate, is unmanageable, becomes violent or threatening, staff and volunteers are instructed to call 911 immediately. An incident report will be completed and the information will be provided to the Supervisor, the Service Navigator and the Police Department, if the incident warrants police intervention.

INCIDENT REPORTS

Winter Shelter staff will complete incident reports for any medical, criminal or disaster-related incidents or emergencies. The purpose of the incident report is to document any observed or

alleged criminal activity or other breach of SVdP policy, and to monitor the frequency of Winter Shelter disturbances. Clients will be warned and notified of their incident documentation and are privileged to review their own incident reports at any time. Incident reports are only to be completed by staff and will be saved in the client's confidential file. All relevant incidences of observed or alleged criminal activity shall be immediately reported to the Santa Rosa Police Department with a copy of the applicable incident report when completed.

LAW ENFORCEMENT PERSONNEL

The Armory is a publicly owned and operated facility of the State of California, which is being licensed to the County of Sonoma. Accordingly, the Armory will be subject to routine patrol by the Santa Rosa Police Department. Participants in the shelter program will not have the same expectation of privacy as might otherwise exist in a privately-owned facility or residence. The Santa Rosa Police Department maintains its own separate access to the Armory through pre-existing protocols with Armory staff. Shelter staff shall not impede access to the Armory by law enforcement personnel. EMT's/EMS personnel are permitted to enter a Facility without delay when they have been summoned to the facility by the shelter staff. The staff must note the names and badge numbers or other identifying information of the EMTs. County lawyers and Administrative Officials may arrange a visit to the shelter with the Executive Director. These visitors are to be escorted by the supervisor in charge unless instructed otherwise.

PERSONAL VISITORS

Non-shelter visitors are not permitted at the Winter Shelter program.

GUIDELINES FOR SHELTER CLIENTS

Homeless individuals are often coping with a great deal and require patience and support. At times, an individual may not be in the mindset to stay in the shelter for a night; this does not automatically disqualify him/her from the next night. It is to the discretion of the lead staff person for the night

Guidelines for Clients

- Clients must participate in the intake process to use services.
- Alcohol, illicit drugs, drug paraphernalia, and weapons are not allowed in the Center/Shelter/Armory at any time.
- Shelter staff has the right to conduct random searches.
- Lights out and activity ceases between the hours of 9:00 p.m. and 6:00 a.m. Earphones must be used with the volume adjusted so only the user can hear it.
- Clients must remain in supervised areas and are not allowed in the "off limits" areas designated by National Guard and/or Shelter Supervisor.
- Smoking is allowed until 9:00 p.m.. only in the area designated for smoking.

- No pets are permitted in or around the Armory at any time with the exception of a registered Service Dog.
- Violence and threats of violence will not be tolerated.
- No fighting, loud or abusive language, or disturbing of other clients and/or staff.
- Theft and vandalism will result in ban from the facility.
- Any sexual activity - including that between married or committed couples - will not be tolerated.
- Shoes and clothes must be worn at all times in the shelter.

Multiple violations require a plan for re-entry:

- A client with three minor violations may result in a suspension from the facility.
- Violence or threat of violence is an automatic two-day suspension, decided on a case by case basis.
- In order to re-enter the facility, a client may be asked to meet with the Shelter Supervisor to discuss the situation and create a behavioral contract. If a client refuses, he/she may not be allowed to return to the shelter.

GUIDELINES FOR INTERACTING WITH SHELTER CLIENTS

The entire Winter Shelter community is built on personal respect toward clients, volunteers, agency representatives and staff, and an appreciation of the personal dignity of each individual. Shelter clients may come with many problems. They should be viewed as individuals who are survivors with specific strengths. Every interaction should take place in a friendly, yet professional manner. Volunteers will carefully listen to client concerns and convey this information to the shelter’s professional staff as soon as possible. All information disclosed should be kept confidential.

Staff: Employ Empathy

Be sensitive to the conditions that may be affecting a homeless individual’s sense of self. Be considerate and aware of the potential challenges listed below:

- The effect of constant vigilance for safety: lack of sleep, fearfulness, suspicion and insecurity.
- Social isolation: being shunned by others or being treated as invisible, missing out on ordinary conversation or companionship. Despite the lack of privacy in shelters and public places, huge walls of isolation surround the homeless.
- Use of drugs or alcohol: Sometimes loneliness or frustration is relieved by drugs and alcohol. For some people, this is their basic means of creating a sense of community and kinship. Use of these substances can also exacerbate symptoms of mental illness.
- Poor diet: Inadequate nutrition contributes to biochemical imbalances and may cause alterations in mood. Irregular and improper diet is usually high in carbohydrates, sugar and caffeine. Physical Illness: Common illnesses among homeless individuals

- can cause signs and symptoms of mental illness, i.e. malnutrition, intoxication, untreated seizures, untreated diabetes, etc.
- Being moved from shelter to shelter: Uncertainty, disruption, and lack of routine are extremely wearing, especially if a person has little control over these decisions.
 - Lack of medical, psychiatric or other needed help: Obtaining benefits and care is much more difficult for people without a permanent address.

Boundaries in Shelter Service Settings

There are several reasons why it is important to maintain boundaries as a shelter staff client or volunteer; it ensures that:

1. The clients do not become too dependent on you. This partnership is intended to encourage independence;
2. The expectations of the client are clear. Your relationship is a professional one;
3. You are clear about what your role is. What your duties are and what they are not.

This will help you to stay focused on the work you are doing. Boundary guidelines are intended to protect the safety and well-being of you and the clients of the shelter. Please be mindful of the following:

- You should not give your home phone number or your address to clients.
- You should not accept gifts from clients, unless approved by the Supervisor.
- It is fine to be friendly with your client, but you should remember that your relationship is a professional one, and boundaries are important to remember. For example, hugs may or may not be appropriate and can be construed differently by both parties.
- If there is ever a time when you are not sure what is appropriate, please ask the Supervisor for guidance.
- You should not take personal responsibility for a client.
- You should not do special favors for a client.
- You should not become socially or romantically involved with a client.
- You should not transport, loan money, or give personal gifts to a client.

These are but a few of the behaviors and feelings that can occur. All of them violate the policies of the shelter. It should be remembered that personal involvement with a client complicates, compromises, and reduces your ability to be objective and offer quality services.

Maintaining the clarity of roles and boundaries between staff/volunteers and those served enhances the quality of service. It is the responsibility of staff/volunteers to set appropriate boundaries and consistently maintain those boundaries. If you question an appropriate response, please check with the most senior staff for guidance.

Staying Calm in Shelter Service Settings

It is important to remember that situations can arise at any time that may be unusual, difficult or emotional. It is necessary that we try to the best of our ability to handle the problem in a calm and straightforward manner. This will help to ensure the safety and well-being of everyone involved. Anxiety can be contagious. We need to remain focused and calm throughout any situation. Breathe deeply when you feel your anxiety level rising. This will help you relax. If an individual seems upset or angry, do not take it personally. Yelling or raising your voice at someone who is already upset will just make the situation escalate. Avoid confrontational statements when dealing with someone who appears angry. Acknowledge the fact that the person is upset and ask if they would like to talk about it or offer them a quiet corner to sit and relax for a few minutes until they can regain control of their emotions.

Remember that often we are dealing with individuals with very high anxiety and stress levels who may just need a chance to talk to someone. Remaining calm and non-judgmental may help the individual express their emotions in a calmer way. Remember that these conversations are not to be shared with others. If you have anxiety about a situation or client, remove yourself from the situation & contact a senior staff person immediately.

MANAGING CHALLENGING EVENTS AND BEHAVIORS

Managing challenging events and behaviors involves:

1. De-escalation.
2. Follow-up.
3. Documentation (Incident Report).

Physical Force is NEVER recommended. Physical force should only be used as a last resort to prevent injury to you or to another person. De-escalation helps make a dangerous, or threatening, situation more manageable. De-escalation involves being keenly aware of YOUR response to the challenging behavior. De-escalate with your body language, personal space and tone of voice.

Be aware of your body language:

- Finger pointing may seem accusing or threatening.
- Shoulder shrugging may seem uncaring or unknowing.
- Rigid walking may seem unyielding or challenging.
- Jaw set with clenched teeth shows you are not open- minded to listening to his/her side of the story.
- A natural smile is good. A fake smile can aggravate the situation.
- Use slow and deliberate movements -- quick actions may surprise or scare the other person.

Be mindful of personal space:

- Invasion or encroachment of personal space tends to heighten or escalate anxiety.
- Note: Personal space is usually 1.5 to 3 feet or far enough apart so you cannot be hit or kicked.
- Do not touch a person. HE or she might interpret that as an aggressive action.
- Keep your hands visible at all times. You do not want the other person to misinterpret your physical actions.

Watch your tone and volume of your voice:

- A lowered voice level may set a tone of anger which could create fear or challenges. A raised voice may set a tone of anticipation or uncertainty which may promote excitement or disruption. A controlled voice is one of calm and firmness which promotes confidence in both parties.
- Speak slowly. This is often soothing.
- Humor may unintentionally offend someone and escalate the situation. -- Use humor sparingly and always direct humor toward yourself. (Be very careful when attempting humor in this type of situation).
- Always be respectful to the other person. Using “please” and “thank-you” -- “Mr.” or “Ms.” indicates respect.
- Empathize with the other person.
- events.

SAFETY & SECURITY

A Security Guard is on duty from 7:00 pm to 10:00 pm. The security guard is responsible for patrolling the perimeter and for checking for anything that could be used as a weapon.

Clients are expected to be respectful or may be asked to leave. Staff is only to use hands-on force in self-defense, and should always attempt to de-escalate the situation first.

Staffing: A minimum of one staff member shall be on duty at the Armory at all times.

Safety Guidelines

- Potential weapons (pocket knives, box, cutters, etc.) must be checked in upon admittance and will be returned to the client upon checkout.
- Physical violence and threats will not be tolerated.
- Profanity and harassment will not be tolerated.
- Any type of altercation should be handled by Winter Shelter staff only. If a volunteer witnesses such an altercation, contact a staff person immediately.
- Only current shelter clients, staff, volunteers, agency representatives, law enforcement and paramedics with proper credentials will be allowed entrance to the shelter during the hours of operation.

- Except for Santa Rosa Police Department personnel, all individuals must be checked in by shelter staff during operational hours.
- It should be noted that any occurrence that has the potential to endanger volunteers, staff or visitors must be dealt with in a calm and direct manner.

In all situations the well-being of individuals in the immediate area must be safeguarded. If necessary and appropriate, move everyone, except those immediately dealing with the crisis to a secure area. Volunteers should take directions from staff as to whether or not their assistance is needed in such situations. It is important to remember that once the crisis has been dealt with, it may be helpful for staff, volunteers, and clients to meet to calm anyone who may be concerned or upset.

HEALTH POLICIES AND PROCEDURES

Health Policies & Procedures

At all times during shelter operation, one member of staff will serve as the Public Health Liaison. This individual is familiar with the requirements of the National Guard's License Agreement to uphold policies and practices outlined in the Los Angeles Department of Public Health Airborne Illness Mitigation and Prevention Practices, as well as local Sonoma County Department of Public Health Policies and Procedures, and apply them appropriately to daily shelter operations. This individual will also have current Basic CPR and First Aid certification and act as a lay responder in the event of an emergency.

Physical symptoms to be concerned about include coughing, disorientation, expressed dizziness or appearing to be overly exhausted (lethargic). These could be just from living on the streets, but they could be symptoms of a sickness that needs treatment at a medical facility. Remember that many signs of mental illness are sometimes similar to intoxication and/or drug abuse. If a client asks you to contact 911, please do not hesitate to call.

Shelter Organization:

- Designate a sick area in shelter.
- Place mattresses head to toe to help slow the spread of a virus through coughing and contact. During intake, ask clients if they are feeling feverish and coughing. If yes, reassure them they will have a place to stay and use stick-on thermometers to determine if they have a fever.
- Have trash cans readily available for tissues. Empty them frequently.
- Keep hand sanitizer (must be > 60% alcohol to be effective). Large-sized, non-portable bottles may be best.
- Encourage clients to wash their hands often, especially after coughing or sneezing. Keep liquid soap on hand and use hot water.
- If possible, have lotion available, as the sanitizers and washing dry out skin quickly.

- Have surgical masks available (drywall masks work just fine) for clients who are coughing and staff working in sick area/room.
- Have good signage demonstrating how to slow the spread of germs (cover a cough, use hand sanitizer, etc.)

Intake area:

- Everyone uses hand sanitizer.
- Reassure people that there is a special accommodation area for clients who are sick.
- Try to give some basic education on how to slow the spread of illnesses (cover cough, don't share cigarettes, etc.).
- Use common sense or enlist the help of someone with first aid experience to determine if a person's illness is serious enough to warrant calling an ambulance.
- Do not hesitate to call for an ambulance if necessary. If an individual needs urgent care but is not sick enough to require emergency transportation, inform the staff lead. They may be able to arrange for alternative transportation.
- Avoid unnecessary contact with symptomatic people and keep social distance of at least six feet. Wash hands often, especially after sneezing, coughing or contact with people who are sneezing or coughing.

Universal Health Precautions in the majority of workplaces such as schools, factories and offices you are not at risk for Human Immunodeficiency Virus (HIV), Hepatitis A, Hepatitis B (HBV), Hepatitis C (HCV) or other infections. However, in certain situations you may come into contact with blood or other potentially infectious body fluids. This can occur any time blood or other potentially infectious body fluids come into contact with broken skin or mucous membranes. Universal Precautions*are measures intended to protect you from such exposures. Contact with blood, all body fluids, secretions and excretions (except sweat) regardless of whether or not they contain visible blood should be avoided. The risk of HIV, HBV or HCV infection from other body substances (such as tears) is extremely low or nonexistent. Feces can contain bacteria, viruses or parasites. Nasal secretions can contain viruses or bacteria.

How to reduce transmission risks:

The list of six techniques for reducing transmission risks are explained in further detail below:

- 1.) Wash Hands Frequently.
- 2.) Wear Gloves.
- 3.) Wear Other Protective Barriers as Necessary.
- 4.) Clean Contaminated Surfaces.
- 5.) Dispose of Contaminated Articles.
- 6.) Report Any Exposure Immediately.
- 7.) Wash Your Hands: Hand washing remains your best defense against any infection, including HIV HBV and HCV.
- 8.) Wash your hands thoroughly before and after exposure to blood and body fluids, secretions and excretions and following the removal of gloves.

9.) **Wear Gloves:** Wear vinyl gloves for all contact with blood and body fluids, secretions and excretions and for wiping up contaminated surfaces and performing first aid.

Wear Other Protective Barriers:

Wear other protective barriers as necessary to reduce your risk of exposure to potentially infectious body fluids on broken skin or mucous membranes. Always wear a protective barrier when there will be contact with blood and body fluids.

Masks/Protective Eye Wear/Clothing:

Wear protective eye glasses and/or masks during procedures that are likely to produce aerosols or splashes of blood and body fluids that may contact the mucous membranes of the eyes, nose, or mouth.

Resuscitation Devices:

To minimize your exposure during emergency mouth-to-mouth resuscitation, mouth pieces, resuscitation bags or other ventilation devices should be available. However, the risk of infection remains low and no one should hesitate to give emergency mouth-to-mouth resuscitation without a mouth piece.

Clean Contaminated Surfaces:

Wear gloves and immediately wipe up spills of potentially infected material with paper towels and dispose of them carefully as per process below. Wash area with hot water and a household cleaner. Rinse. Apply a freshly made solution of household bleach (1/3 cup bleach to 1 gallon of water) to the area. Leave solution on affected area for 10 minutes, then wipe it up.

Dispose of Contaminated Articles:

Report any exposure immediately to Shelter Supervisor or staff lead and your family doctor. Ensure there is an incident report on file.

Contaminated Waste:

Dispose of articles soiled with blood or body fluids in a plastic bag tied at the top. If the first bag is visibly soiled or leaking, double bag the article before discarding in the garbage.

If any of the following medical emergency conditions are present, call 911 and request an ambulance immediately. Do not transport the client to the hospital:

- Severe vomiting or blood present in vomit.
- Difficulty breathing.
- Profuse bleeding.

- Dizziness.
- Suspected broken bones.
- Injury as a result of criminal assault.
- Complications of pregnancy.
- Drug overdose, suicidal ideation or attempt.
- Seizures.
- Intermittent consciousness or any instances of unconsciousness.

If an ambulance is called and the client is unable to communicate, you may provide medics with the client's name, age, gender, medical history, medications, and the lead staff's contact information and the contact information for any staff who witnessed the incident.

You may provide your observations in terms of behavior and the client's symptoms. However, safeguard the client's confidentiality in all other matters. An incident report will need to be completed. In medical emergencies, do not provide treatment except for basic first aid and CPR. This includes over-the-counter medications, water, laxatives, antacids, aspirin, Tylenol, or any other substance or procedure. These may worsen conditions, mask symptoms, or complicate medical treatment.

Death in Shelter:

The following steps should be taken if death occurs in the shelter:

- 1.) Call 911 or designate a responsible person to call for you.
- 2.) Verify that the person is without a pulse and/or not breathing.
- 3.) Insure that you or a responsible person is comforting and staying with affected clients.
- 4.) The emergency medical technician or fireman who responds will contact the coroner.
- 5.) Be calm.
- 6.) Document situation in the shift log.
- 7.) Complete an incident report.

FIRE AND DISASTER EMERGENCIES

Prior to lights out every night, the designated Fire Watch shall inform all shelter clients of the nearest exits and evacuation procedures, as outlined in the site plan designs. In the event of a fire, the designated Fire Watch shall sound a bull horn three times to notify shelter clients of smoke or an active fire. All presiding staff and volunteers shall help direct people to the nearest exit, and ensure that clients with disabilities are safely evacuated. A designated Fire Watch will be on-site at all times and be familiar with evacuation protocol and procedures. The Fire Watch duty will reside with the Supervisor, Assistant Supervisors and Coordinators. At least one onsite staff member will also maintain a current Basic First Aid and CPR certification to act as a lay responder until EMS personnel arrive.

In the case of fire:

- 1.) Call 911;
- 2.) Sound the bull horn three times;
- 3.) Get everyone out of the building as quickly as possible using the most logical route away from the fire;
- 4.) Do not stay near the building, but move everyone to the far side of the parking lot (at least 50 feet or more to create a clear path for firefighters);
- 5.) If exiting people through the rear of the Armory, assemble people 50 feet away from the rear of building. Make sure people stay together and do not wander into Armory equipment and asset areas;
- 6.) Once the building is clear, a National Guard Representative will escort the evacuees from the rear through the locked gate into the front parking lot. Refer to the Outer-Armory Site Design for details.

In the case of an earthquake:

- 1.) Sound the bull horn three times;
- 2.) Move people out of the building as quickly as possible;
- 3.) Do not stay near the building, but move everyone to the far side of the parking lot;
- 4.) If exiting people through the rear of the Armory, assemble people 50 feet away from the building. Make sure people stay together and do not wander into Armory equipment and asset areas;
- 5.) Once the building is clear, a National Guard Representative will escort the evacuees from the rear through the locked gate into the front parking lot. Refer to the inside and outside Site Plan for details (Exhibit A);
- 6.) In all cases, use common sense, move with determined speed and make sure all people are accounted for as you move from place to place;
- 7.) Notify EMS responders if medical attention is required.

Duties of the Fire Watch:

- 1.) Always be watching for fire hazards in the shelter. This can be combustible material on the drill floor, loose or frayed wiring, or the presence of a flammable liquid;
- 2.) Ensure that conditions on the fire permit are always upheld and maintained;
- 3.) Keep flammable materials away from ignition sources;
- 4.) Be watchful for smoke and/or flames. If smoke or flames are seen, initiate fire protocol and evacuation procedures;
- 5.) If a fire is identified, direct a fellow staff client to call 911, and then proceed to extinguish the flame;
- 6.) Ensure that all new staff personnel and volunteers are aware of the four extinguishers on the drill floor and three exits of the armory. Ensure that all staff and volunteers understand the evacuation procedure and can perform an evacuation duty;
- 7.) Ensure that all staff clients are properly trained to use a fire extinguisher. Remember, point the nozzle at the base of the flame, and sweep from side to side.

- 8.) Maintain a nightly fire log on a nightly basis to document any identified risks and/or any incidents that occurred. Be sure to report identified risks to the Shelter Supervisor. For a downloadable and printable fire log follow this link: <http://smfdwi.org/wp-content/uploads/2014/01/Fire-Watch-Log-Sheet.pdf>.

I certify that I have read the Santa Rosa Armory Temporary Winter Shelter Operations Handbook, and I affirm that I will execute all of the duties, policies, and procedures listed above to the best of my ability.

Signed:

Employee/Volunteer Signature

Date

EXHIBIT A:

SITE PLANS FOR EMERGENCY EVACUATION

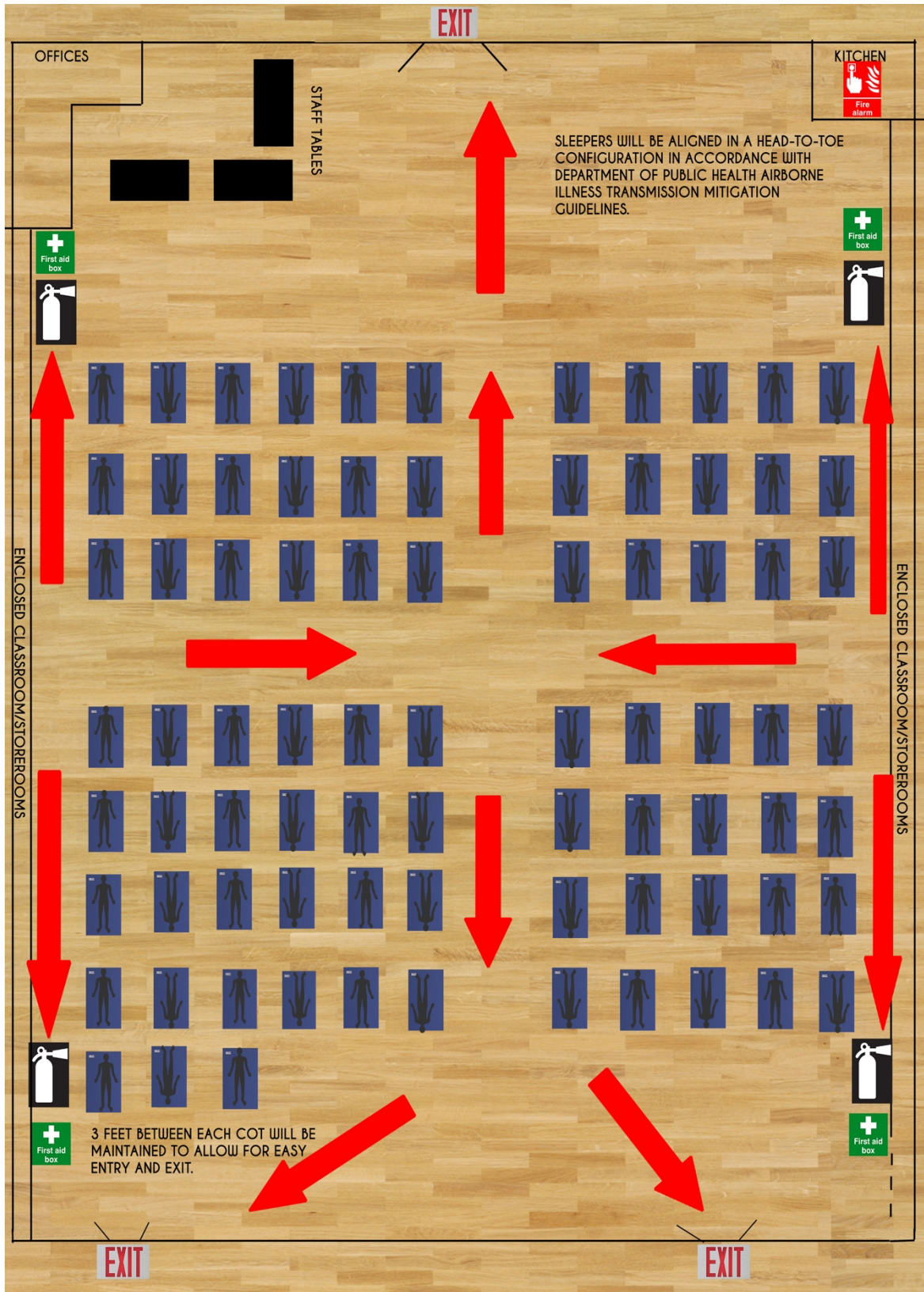

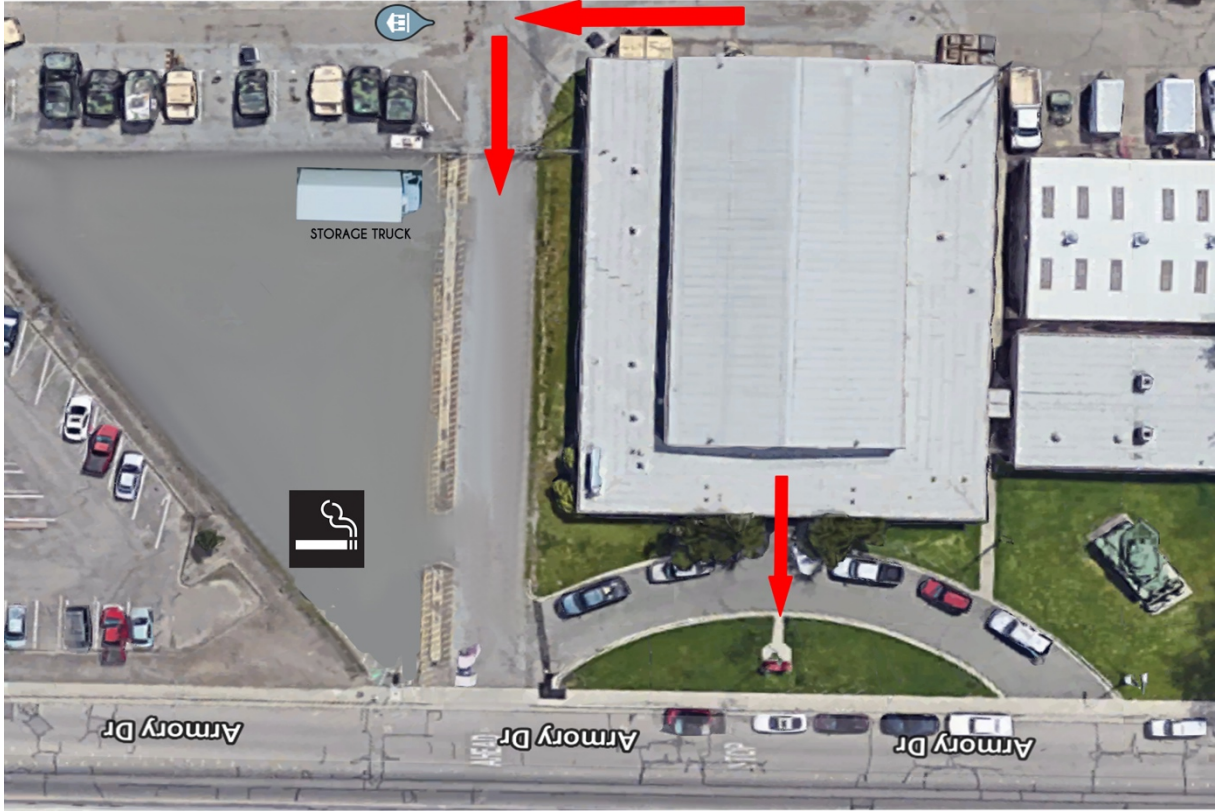



County of Sonoma Agenda Item Summary Report

Clerk of the Board
575 Administration Drive
Santa Rosa, CA 95403

Agenda Item Number: 6
(This Section for use by Clerk of the Board Only.)

To: Boards of Directors: Sonoma County Water Agency; and Occidental, Russian River, Sonoma Valley, and South Park County Sanitation Districts

Board Agenda Date: November 13, 2018

Vote Requirement: Majority

Department or Agency Name(s): Sonoma County Water Agency and Occidental, Russian River, Sonoma Valley, and South Park County Sanitation Districts

Staff Name and Phone Number:

Eric Wilhelm 707-524-1172

Supervisory District(s):

Title: As-Needed Supervisory Control and Data Acquisition System Support and Related Services

Recommended Actions:

Authorize Sonoma County Water Agency's General Manager to execute an agreement with CH2M HILL Engineers, Inc. for as-needed supervisory control and data acquisition system support and related services through July 30, 2021, in an amount not to exceed \$1,000,000. These consultant services will help Sonoma Water maintain and improve its industrial systems infrastructure, which is needed to efficiently and safely conduct daily water and wastewater operations.

Executive Summary:

Sonoma County Water Agency (Sonoma Water) uses various equipment and protocols in supervisory control and data acquisition system operations at Sonoma Water's facilities. Sonoma Water requires as-needed support for the maintenance, repair, design, programming, installation, and other related services for this system.

Discussion:

HISTORY OF ITEM/BACKGROUND

Sonoma County Water Agency, Occidental County Sanitation District, Russian River County Sanitation District, Sonoma Valley County Sanitation District, and South Park County Sanitation District (collectively Sonoma Water) require additional support services for the maintenance, repair, design, programming, installation, and other related services of supervisory control and data acquisition, programmable logic controllers, human machine interface, variable frequency drivers, and controllers at its facilities. Sonoma Water has previously contracted these services on an as-needed basis in prior years to augment resources needed for efficient completion of large projects and to provide Sonoma Water with guidance and expertise on industrial control system design review, planning and implementation. Sonoma Water has begun an initiative to upgrade and standardize on industrial control system technologies and contracted

services will be required to provide the necessary capacity and expertise to handle new initiatives on top of ongoing operations and maintenance.

Sonoma Water owns, operates and manages Airport/Larkfield/Wikiup Sanitation Zone, Geyserville Sanitation Zone, Penngrove Sanitation Zone, and Sea Ranch Sanitation Zone.

Sonoma Water operates and manages Occidental, Russian River, Sonoma Valley, and South Park County Sanitation Districts under contract with these entities.

SELECTION PROCESS

On November 8, 2017, Sonoma Water issued a Request for Statements of Qualifications, which posted to the Sonoma Water and County Purchasing Department websites, and was sent to the following five firms:

1. CH2M Hill, Sacramento, CA
2. Carollo, Walnut Creek, CA
3. E&M, Healdsburg, CA
4. TESCO Controls, Sacramento, CA
5. Westin, Rancho Cordova, CA

The three firms listed below submitted Statements of Qualifications:

1. CH2M Hill, Redding, CA
2. Telstar, Sacramento, CA
3. Tesco Controls, Sacramento, CA

The following criteria were used to evaluate each firm: thoroughness of statements of qualifications, professional qualifications and demonstrated ability to perform the work, and exceptions to standard terms in the sample agreement.

CH2M HILL Engineers, Inc. (Consultant) was selected to perform the work because Consultant is a multidiscipline engineering firm with extensive experience supporting municipalities across the U.S. in the water and wastewater industry. Consultant brings experience across a wide range of technologies that can assist Sonoma Water not just with programmable logic controllers and human machine interface systems, but also with radio communications and integrating operational data with asset management and computerized maintenance management systems.

SERVICES TO BE PERFORMED

Under the proposed agreement, Consultant will provide as-needed support services including, but not limited to, assistance with system integration, programming, repairs to existing computers, consulting, design, installation, documentation, AutoCAD drawings, training, maintenance, and after hours and emergency on-site service for the supervisory control and data acquisition system operations.

The cost of services will not exceed \$1,000,000; the term end date is July 30, 2021. Billing rates in the prior CH2M HILL Engineers contract for similar services were stated to escalate by 3% at the beginning of each

calendar year. The rate structure proposed under the new contract follows this same annual cost inflation schedule.

RECOMMENDATION

Sonoma Water staff recommends that the Board authorize Sonoma Water's General Manager to execute an agreement with CH2M HILL Engineers, Inc. for as-needed supervisory control and data acquisition system support and related services through July 30, 2021, in an amount not to exceed \$1,000,000.

Prior Board Actions:

- 04/15/2014: Approved agreement between Sonoma Water and CH2M HILL Engineers, Inc. for as-needed support for supervisory control and data acquisition systems and related services. Cost \$450,000; term end June 30, 2016.
- 06/15/2010: Approved agreement between Sonoma County Water Agency, the Russian River County Sanitation District, and the Sonoma Valley River County Sanitation District and ZSI, Inc. for computer maintenance services at wastewater treatment plants and water systems. Cost \$461,495; term end June 30, 2013.

Strategic Plan Alignment Goal 3: Invest in the Future

Additional resources are necessary to maintain a reliable communication and supervisory control and data acquisition infrastructure foundation on which to efficiently conduct water and wastewater operations today and in the future.

Sonoma Water Strategic Plan Alignment

Information Technology, Goal 1: Increase security, usability and efficiency of Information Technology (IT) Systems.

Upgrades to Sonoma Water infrastructure proposed in this item will support IT system efficiency and usability.

Fiscal Summary			
Expenditures	FY 18-19 Adopted	FY 19-20 Projected	FY 20-21 Projected
Budgeted Expenses	\$1,000,000		
Additional Appropriation Requested			
Total Expenditures	\$1,000,000		
Funding Sources			
General Fund/WA GF	\$500,000		
State/Federal			
Fees/Other	\$500,000		
Use of Fund Balance			
Contingencies			
Total Sources	\$1,000,000		
Narrative Explanation of Fiscal Impacts:			
Budgeted amount of \$500,000 each is available from FY 2018/2019 appropriations for the Sonoma Water General Fund and Water Transmission Common Facilities Fund. No additional appropriation is requested.			
Staffing Impacts			
Position Title (Payroll Classification)	Monthly Salary Range (A – I Step)	Additions (Number)	Deletions (Number)
N/A			
Narrative Explanation of Staffing Impacts (If Required):			
N/A			
Attachments:			
Agreement			
Related Items “On File” with the Clerk of the Board:			
None			

rw S:\Agenda\agrees\11-13-2018 WA As-Needed SCADA System Support and Related Services_summ.docm

CF/0-0-21 RFQ (Agree for As-Needed SCADA System Support and Related Services) 16/17-121 (ID 6715)

Agreement for As-Needed SCADA System Support and Related Services

This agreement (“Agreement”) is by and between **Sonoma County Water Agency, Occidental County Sanitation District, Russian River County Sanitation District, Sonoma Valley County Sanitation District, and South Park County Sanitation District** collectively referred to as “Sonoma Water”) and **CH2M HILL Engineers, Inc.**, a Delaware corporation (“Consultant”). The Effective Date of this Agreement is the date the Agreement is last signed by the parties to the Agreement, unless otherwise specified in Paragraph 6.1.

RECITALS

- A. Consultant certifies that it is a Delaware state corporation duly authorized to do business in the State of California, registered with the Secretary of State of California, and represents that it is a duly qualified and licensed multidiscipline engineering firm, experienced in supporting supervisory control and data acquisition (SCADA) systems and related services.
- B. Sonoma Water uses various equipment and protocols in SCADA system operations at Sonoma Water’s facilities, and requires as-needed support for the maintenance, repair, design, programming, installation, and other related services for this system.
- C. Sonoma County Water Agency operates and manages Airport/Larkfield/Wikiup Sanitation Zone, Geyserville Sanitation Zone, Penngrove Sanitation Zone, and Sea Ranch Sanitation Zone (“Zones”).
- D. Sonoma County Water Agency operates Occidental County Sanitation District, Russian River County Sanitation District, Sonoma Valley County Sanitation District, and South Park County Sanitation District (“Districts”) under contract with Districts. References to District employees are understood to be Sonoma County Water Agency employees acting on behalf of Districts.

In consideration of the foregoing recitals and the mutual covenants contained herein, the parties hereto agree as follows:

AGREEMENT

1. RECITALS

- 1.1. The above recitals are true and correct.

2. LIST OF EXHIBITS

- 2.1. The following exhibits are attached hereto and incorporated herein:
 - a. Exhibit A: Agreement Memorandum
 - b. Exhibit B: Scope of Work
 - c. Exhibit C: Schedule of Rates

d. Exhibit D: Insurance Requirements

3. SONOMA WATER'S REQUEST FOR SERVICES

- 3.1. *Initiation Conference:* Sonoma Water's Agreement Administrator, Eric Wilhelm, will initiate requests for services through an Initiation Conference, which may be in person, by telephone, or by email. During the Initiation Conference, the Project Manager and Consultant will establish and agree on the project information shown in Exhibit A (Agreement Memorandum).
- 3.2. *Agreement Memorandum:* Sonoma Water will prepare an Agreement Memorandum setting forth the terms for the subject project as established during the Initiation Conference. The Agreement Memorandum will be in the form as set forth in Exhibit A and will be executed by both parties prior to commencement of work.
- 3.3. *Amount of Work:* Sonoma Water does not guarantee a minimum or maximum amount of work.

4. SCOPE OF SERVICES

- 4.1. *Consultant's Specified Services:* Consultant shall perform the services listed in Exhibit B (Scope of Work) or as requested in the Agreement Memorandum, within the times or by the dates provided in the Agreement Memorandum and pursuant to Article 10 (Prosecution of Work). Consultant shall provide necessary manpower and equipment required to carry out the requested services in a professional and expeditious manner.
- 4.2. *Contact Information:*

Sonoma Water	Consultant
Agreement Administrator: Eric Wilhelm 404 Aviation Boulevard Santa Rosa, CA 95403-9019 Phone: 707-524-1172 Email: Eric.Wilhelm@scwa.ca.gov	Contact: Jerry Dehn 2525 Airpark Drive Redding, CA 96001 Phone: 530-229-3447 Email: Jerry.Dehn@ch2m.com
Remit invoices to: Susan Bookmyer Same address as above or Email: susan.bookmyer@scwa.ca.gov	Remit payments to: CH2M HILL Engineers, Inc. P.O. Box 201869 Dallas, TX 75320-1869

- 4.3. *Cooperation with Sonoma Water:* Consultant shall coordinate the work with the Project Manager named in the Agreement Memorandum.

4.4. *Performance Standard and Standard of Care:* Consultant hereby agrees that all its work will be performed and that its operations shall be conducted in accordance with the standards of a reasonable professional having specialized knowledge and expertise in the services provided under this Agreement and in accordance with all applicable federal, state and local laws, it being understood that acceptance of Consultant's work by Sonoma Water shall not operate as a waiver or release. Sonoma Water has relied upon the professional ability and training of Consultant as a material inducement to enter into this Agreement. If Sonoma Water determines that any of Consultant's work is not in accordance with such level of competency and standard of care, Sonoma Water, in its sole discretion, shall have the right to do any or all of the following: (a) require Consultant to meet with Sonoma Water to review the quality of the work and resolve matters of concern; (b) require Consultant to repeat the work at no additional charge until it is satisfactory; (c) terminate this Agreement pursuant to the provisions of Article 7 (Termination); or (d) pursue any and all other remedies at law or in equity.

4.5. *Assigned Personnel:*

- a. Consultant shall assign only competent personnel to perform work hereunder. In the event that at any time Sonoma Water, in its sole discretion, desires the removal of any person or persons assigned by Consultant to perform work hereunder, Consultant shall remove such person or persons immediately upon receiving written notice from Sonoma Water.
- b. Any and all persons identified in this Agreement or any exhibit hereto as the project manager, project team, or other professional performing work hereunder are deemed by Sonoma Water to be key personnel whose services were a material inducement to Sonoma Water to enter into this Agreement, and without whose services Sonoma Water would not have entered into this Agreement. Consultant shall not remove, replace, substitute, or otherwise change any key personnel without the prior written consent of Sonoma Water.
- c. Key personnel shall be as listed in the applicable Agreement Memorandum.
- d. In the event that any of Consultant's personnel assigned to perform services under this Agreement become unavailable due to resignation, sickness, or other factors outside of Consultant's control, Consultant shall be responsible for timely provision of adequately qualified replacements.

5. **PAYMENT**

5.1. *Total Costs:* Total costs under this Agreement shall not exceed \$1,000,000.

5.2. *Method of Payment:* Consultant shall be paid in accordance with the following terms:

- a. Consultant shall be paid in accordance with Exhibit C (Schedule of Rates). Billed hourly rates shall include all costs for overhead and any other charges,

other than expenses specifically identified in Exhibit C. Expenses not expressly authorized by the Agreement shall not be reimbursed.

- 5.3. *Invoices:* Consultant shall submit its bills in arrears on a monthly basis, based on work completed for the period, in a form approved by Sonoma Water. The bills shall show or include:
- a. Consultant name
 - b. Name of Agreement
 - c. Sonoma Water's Project-Activity Code as listed in the applicable Agreement Memorandum.
 - d. Task performed with an itemized description of services rendered by date
 - e. Time in quarter hours devoted to the task
 - f. Hourly rate or rates of the persons performing the task
 - g. Summary of work performed by subconsultants, as described in Paragraph 15.4
- 5.4. *Timing of Payments:* Unless otherwise noted in this Agreement, payments shall be made within the normal course of Sonoma Water business after presentation of an invoice in a form approved by Sonoma Water for services performed. Payments shall be made only upon the satisfactory completion of the services as determined by Sonoma Water.
- 5.5. *Taxes Withheld by Sonoma Water:*
- a. Pursuant to California Revenue and Taxation Code (R&TC) section 18662, Sonoma Water shall withhold seven percent of the income paid to Consultant for services performed within the State of California under this Agreement, for payment and reporting to the California Franchise Tax Board, if Consultant does not qualify as: (1) a corporation with its principal place of business in California, (2) an LLC or Partnership with a permanent place of business in California, (3) a corporation/LLC or Partnership qualified to do business in California by the Secretary of State, or (4) an individual with a permanent residence in the State of California.
 - b. If Consultant does not qualify, as described in Paragraph 5.5.a, Sonoma Water requires that a completed and signed Form 587 be provided by Consultant in order for payments to be made. If Consultant is qualified, as described in Paragraph 5.5.a, then Sonoma Water requires a completed Form 590. Forms 587 and 590 remain valid for the duration of the Agreement provided there is no material change in facts. By signing either form, Consultant agrees to promptly notify Sonoma Water of any changes in the facts. Forms should be sent to Sonoma Water pursuant to Article 16 (Method and Place of Giving Notice, Submitting Bills, and Making Payments) of this Agreement. To reduce the amount withheld, Consultant has the option to provide Sonoma Water with either a full or partial waiver from the State of California.

6. TERM OF AGREEMENT AND COMMENCEMENT OF WORK

- 6.1. *Term of Agreement:* This Agreement shall remain in effect until depletion of the not-to-exceed amount listed in Paragraph 5.1, or until July 30, 2021, whichever occurs first, unless terminated earlier in accordance with the provisions of Article 7 (Termination).
- 6.2. *Commencement of Work:* Consultant is authorized to proceed with work upon receipt of each fully executed Agreement Memorandum.

7. TERMINATION

- 7.1. *Authority to Terminate:* Sonoma Water's right to terminate may be exercised by Sonoma County Water Agency's General Manager.
- 7.2. *Termination Without Cause:* Notwithstanding any other provision of this Agreement, at any time and without cause, Sonoma Water shall have the right, in its sole discretion, to terminate this Agreement by giving 5 days written notice to Consultant.
- 7.3. *Termination for Cause:* Notwithstanding any other provision of this Agreement, should Consultant fail to perform any of its obligations hereunder, within the time and in the manner herein provided, or otherwise violate any of the terms of this Agreement, Sonoma Water may immediately terminate this Agreement by giving Consultant written notice of such termination, stating the reason for termination.
- 7.4. *Delivery of Work Product and Final Payment Upon Termination:* In the event of termination, Consultant, within 14 days following the date of termination, shall deliver to Sonoma Water all reports, original drawings, graphics, plans, studies, and other data or documents, in whatever form or format, assembled or prepared by Consultant or Consultant's subcontractors, consultants, and other agents in connection with this Agreement subject to Paragraph 13.10 and shall submit to Sonoma Water an invoice showing the services performed, hours worked, and copies of receipts for reimbursable expenses up to the date of termination.
- 7.5. *Payment Upon Termination:* Upon termination of this Agreement by Sonoma Water, Consultant shall be entitled to receive as full payment for all services satisfactorily rendered and reimbursable expenses properly incurred hereunder, an amount which bears the same ratio to the total payment specified in the Agreement as the services satisfactorily rendered hereunder by Consultant bear to the total services otherwise required to be performed for such total payment; provided, however, that if services are to be paid on a per-hour or per-day basis, then Consultant shall be entitled to receive as full payment an amount equal to the number of hours or days actually worked prior to termination multiplied by the applicable hourly or daily rate; and further provided, however, that if

Sonoma Water terminates the Agreement for cause pursuant to Paragraph 7.3, Sonoma Water shall deduct from such amounts the amount of damage, if any, sustained by Sonoma Water by virtue of the breach of the Agreement by Consultant.

8. INDEMNIFICATION

8.1. To the fullest extent permitted by law, Consultant agrees to indemnify, hold harmless, and defend Sonoma County Water Agency, Occidental County Sanitation District, Russian River County Sanitation District, Sonoma Valley County Sanitation District, and South Park County Sanitation District, their officers, agents, and employees, from and against any third party actions, claims, damages, liabilities, disabilities, or expenses, that may be asserted by any person or entity, to the extent that they arise out of, pertain to, or relate to Consultant's or its agents', employees', contractors', subcontractors', or invitees' negligence, recklessness or willful misconduct in performance of its Services under this Agreement. Consultant's obligations under this Article 8 apply whether or not there is concurrent or contributory negligence on the part of Sonoma County Water Agency, Occidental County Sanitation District, Russian River County Sanitation District, Sonoma Valley County Sanitation District, or South Park County Sanitation District, but, to the extent required by law, excluding liability due to conduct of Sonoma County Water Agency, Occidental County Sanitation District, Russian River County Sanitation District, Sonoma Valley County Sanitation District, or South Park County Sanitation District. Sonoma County Water Agency, Occidental County Sanitation District, Russian River County Sanitation District, Sonoma Valley County Sanitation District, and South Park County Sanitation District shall have the right to select their legal counsel at Consultant's expense, subject to Consultant's approval, which shall not be unreasonably withheld. This indemnification obligation is not limited in any way by any limitation on the amount or type of damages or compensation payable to or for Consultant or its agents under workers' compensation acts, disability benefits acts, or other employee benefit acts.

9. INSURANCE

9.1. With respect to performance of work under this Agreement, Consultant shall maintain and shall require all of its subcontractors, consultants, and other agents to maintain, insurance as described in Exhibit D (Insurance Requirements).

10. PROSECUTION OF WORK

10.1. Performance of the services hereunder shall be completed within the time required within each Agreement Memorandum, provided, however, that if the performance is delayed by earthquake, flood, high water, or other Act of God or by strike, lockout, or similar labor disturbances, the time for Consultant's performance of this Agreement shall be extended by a number of days equal to the number of days Consultant has been delayed.

- 10.2. When work is requested of Consultant by Sonoma Water, all due diligence shall be exercised and the work accomplished without undue delay, within the performance time specified in the Agreement Memorandum(s).

11. EXTRA OR CHANGED WORK

- 11.1. Extra or changed work or other changes to the Agreement may be authorized only by written amendment to this Agreement, signed by both parties. Changes to lengthen time schedules or make minor modifications to the scope of work, which do not increase the amount paid under the Agreement, may be executed by Sonoma County Water Agency's General Manager in a form approved by County Counsel. The parties expressly recognize that Sonoma Water personnel are without authorization to order all other extra or changed work or waive Agreement requirements. Failure of Consultant to secure such written authorization for extra or changed work shall constitute a waiver of any and all right to adjustment in the Agreement price or Agreement time due to such unauthorized work and thereafter Consultant shall be entitled to no compensation whatsoever for the performance of such work. Consultant further expressly waives any and all right or remedy by way of restitution and quantum meruit for any and all extra work performed without such express and prior written authorization of Sonoma Water.

12. CONTENT ONLINE ACCESSIBILITY

- 12.1. *Accessibility:* Sonoma Water policy requires that all documents that may be published to the Web meet accessibility standards to the greatest extent possible, and utilizing available existing technologies.
- 12.2. *Standards:* All consultants responsible for preparing content intended for use or publication on a Sonoma Water/County-managed or Sonoma Water/County-funded web site must comply with applicable federal accessibility standards established by 36 C.F.R. section 1194, pursuant to section 508 of the Rehabilitation Act of 1973, as amended (29 U.S.C. section 794(d)), and Sonoma Water's Web Site Accessibility Policy located at <http://sonomacounty.ca.gov/Services/Web-Standards-and-Guidelines/>.
- 12.3. *Certification:* With each final receivable intended for public distribution (report, presentations posted to the Internet, public outreach materials), Consultant shall include a descriptive summary describing how all deliverable documents were assessed for accessibility (e.g. Microsoft Word accessibility check; Adobe Acrobat accessibility check, or other commonly accepted compliance check).
- 12.4. *Alternate Format:* When it is strictly impossible due to the unavailability of technologies required to produce an accessible document, Consultant shall identify the anticipated accessibility deficiency prior to commencement of any work to produce such deliverables. Consultant agrees to cooperate with Sonoma Water staff in the development of alternate document formats to

maximize the facilitative features of the impacted document(s); e.g., embedding the document with alt-tags that describe complex data/tables.

- 12.5. *Noncompliant Materials; Obligation to Cure:* Remediation of any materials that do not comply with Sonoma Water's Web Site Accessibility Policy shall be the responsibility of Consultant. If Sonoma Water, in its sole and absolute discretion, determines that any deliverable intended for use or publication on any Sonoma Water/County-managed or Sonoma Water/County-funded Web site does not comply with Sonoma Water Accessibility Standards, Sonoma Water will promptly inform Consultant in writing. Upon such notice, Consultant shall, without charge to Sonoma Water, repair or replace the non-compliant materials within such period of time as specified by Sonoma Water in writing. If the required repair or replacement is not completed within the time specified, Sonoma Water shall have the right to do any or all of the following, without prejudice to Sonoma Water's right to pursue any and all other remedies at law or in equity:
- a. Cancel any delivery or task order
 - b. Terminate this Agreement pursuant to the provisions of Article 7 (Termination); and/or
 - c. In the case of custom Electronic and Information Technology (EIT) developed by Consultant for Sonoma Water, Sonoma Water may have any necessary changes or repairs performed by itself or by another contractor. In such event, Consultant shall be liable for all expenses incurred by Sonoma Water in connection with such changes or repairs.
- 12.6. *Sonoma Water's Rights Reserved:* Notwithstanding the foregoing, Sonoma Water may accept deliverables that are not strictly compliant with Sonoma Water Accessibility Standards if Sonoma Water, in its sole and absolute discretion, determines that acceptance of such products or services is in Sonoma Water's best interest.

13. REPRESENTATIONS OF CONSULTANT

- 13.1. *Status of Consultant:* The parties intend that Consultant, in performing the services specified herein, shall act as an independent contractor and shall control the work and the manner in which it is performed. Consultant is not to be considered an agent or employee of Sonoma Water and is not entitled to participate in any pension plan, worker's compensation plan, insurance, bonus, or similar benefits Sonoma Water provides its employees. In the event Sonoma Water exercises its right to terminate this Agreement pursuant to Article 7 (Termination), Consultant expressly agrees that it shall have no recourse or right of appeal under rules, regulations, ordinances, or laws applicable to employees.
- 13.2. *No Suspension or Debarment:* Consultant warrants that it is not presently debarred, suspended, proposed for debarment, declared ineligible, or voluntarily excluded from participation in covered transactions by any federal department or agency. Consultant also warrants that it is not suspended or debarred from

receiving federal funds as listed in the List of Parties Excluded from Federal Procurement or Non-procurement Programs issued by the General Services Administration.

13.3. *Representation, Warranty and Responsibility as to Data Security:*

- a. Data Security: Consultant shall preserve, and shall ensure that its subconsultants or vendors preserve, the confidentiality, integrity, and availability of Sonoma Water data with administrative, technical and physical measures that conform to generally recognized industry standards and best practices that the selected firm then applies to its own processing environment. Maintenance of a secure processing environment includes, but is not limited to, the timely application of patches, fixes and updates to operating systems and applications as provided by Consultant and/or its subconsultants or vendors. Consultant agrees to, and shall ensure that its subconsultants or vendors, comply with Sonoma Water's current and future information security policies, standards, procedures, and guidelines.
- b. Encryption Requirements: Consultant shall encrypt, and shall ensure that its subconsultants or vendors encrypt, confidential information whether the data is in transit, or at rest, including but not limited to Personally Identifiable Information (PII) or Protected Health Information (e.g. PHI, ePHI).
- c. Security Breach: Consultant shall comply, and shall ensure that its subconsultants or vendors comply, with all applicable laws that require the notification of individuals in the event of unauthorized release of personally identifiable information(PII) or protected health information(e.g. PHI,ePHI) or other event requiring notification. In the event of a breach, or other event requiring notification under applicable law, Consultant shall:
 - i. Notify Sonoma Water by telephone and e-mail within twenty-four (24) hours of any suspected or actual breach of security, intrusion, or unauthorized use or disclosure of information of which Consultant or its agents become aware and/or any actual or suspected use or disclosure of data in violation of any applicable federal or state laws or regulations.
 - ii. Assume responsibility for informing all such individuals in accordance with applicable federal or state laws or regulations.
 - iii. Pursuant to Article 8 (Indemnification) of this Agreement, provide indemnity and other protection as specified therein.
- d. Request to Audit: Consultant will accommodate and upon reasonable notice by Sonoma Water, work with Sonoma Water and/or its subcontractors to submit to a random information security audit. This is to ensure that Consultant's information security practices or standards comply with Sonoma Water's information security policies, standards, procedures, and guidelines. Consultant shall ensure that its subconsultants or vendors comply with this requirement.
- e. Cyber Risk Insurance Requirements: Consultant shall include, and shall ensure that its subconsultants or vendors include, cyber risk insurance

requirements in compliance with County of Sonoma Risk Management standards.

- 13.4. *Taxes:* Consultant agrees to file federal and state tax returns and pay all applicable taxes on amounts paid pursuant to this Agreement and shall be solely liable and responsible to pay such taxes and other obligations, including, but not limited to, state and federal income and FICA taxes. Consultant agrees to indemnify and hold Sonoma Water harmless from any liability which it may incur to the United States or to the State of California or to any other public entity as a consequence of Consultant's failure to pay, when due, all such taxes and obligations. In case Sonoma Water is audited for compliance regarding any withholding or other applicable taxes, Consultant agrees to furnish Sonoma Water with proof of payment of taxes on these earnings.
- 13.5. *Records Maintenance:* Consultant shall keep and maintain full and complete documentation and accounting records concerning all services performed that are compensable under this Agreement and shall make such documents and records available to Sonoma Water for inspection at any reasonable time. Consultant shall maintain such records for a period of four (4) years following completion of work hereunder.
- 13.6. *Conflict of Interest:* Consultant covenants that it presently has no interest and that it will not acquire any interest, direct or indirect, that represents a financial conflict of interest under state law or that would otherwise conflict in any manner or degree with the performance of its services hereunder. Consultant further covenants that in the performance of this Agreement no person having any such interests shall be employed. In addition, if required by law or requested to do so by Sonoma Water, Consultant shall submit a completed Fair Political Practices Commission Statement of Economic Interests (Form 700) with Sonoma Water within 30 calendar days after the Effective Date of this Agreement and each year thereafter during the term of this Agreement, or as required by state law.
- 13.7. *Statutory Compliance/Living Wage Ordinance:* Consultant agrees to comply, and to ensure compliance by its subconsultants or subcontractors, with all applicable federal, state and local laws, regulations, statutes and policies, including but not limited to the County of Sonoma Living Wage Ordinance, applicable to the services provided under this Agreement as they exist now and as they are changed, amended or modified during the term of this Agreement. Without limiting the generality of the foregoing, Consultant expressly acknowledges and agrees that this Agreement is subject to the provisions of Article XXVI of Chapter 2 of the Sonoma County Code, requiring payment of a living wage to covered employees. Noncompliance during the term of the Agreement will be considered a material breach and may result in termination of the Agreement or pursuit of other legal or administrative remedies.

- 13.8. *Nondiscrimination:* Consultant shall comply with all applicable federal, state, and local laws, rules, and regulations in regard to nondiscrimination in employment because of race, color, ancestry, national origin, religion, sex, marital status, age, medical condition, pregnancy, disability, sexual orientation or other prohibited basis. All nondiscrimination rules or regulations required by law to be included in this Agreement are incorporated herein by this reference.
- 13.9. *Assignment of Rights:* Consultant assigns to Sonoma Water all rights throughout the world in perpetuity in the nature of copyright, trademark, patent, right to ideas, in and to all versions of the plans and specifications, if any, now or later prepared by Consultant in connection with this Agreement. Consultant agrees to take such actions as are necessary to protect the rights assigned to Sonoma Water in this Agreement, and to refrain from taking any action which would impair those rights. Consultant's responsibilities under this provision include, but are not limited to, placing proper notice of copyright on all versions of the plans and specifications as Sonoma Water may direct, and refraining from disclosing any versions of the plans and specifications to any third party without first obtaining written permission of Sonoma Water. Consultant shall not use or permit another to use the plans and specifications in connection with this or any other project without first obtaining written permission of Sonoma Water.
- 13.10. *Ownership and Disclosure of Work Product:* All reports, original drawings, graphics, plans, studies, and other data or documents ("documents"), in whatever form or format, assembled or prepared by Consultant or Consultant's subcontractors, consultants, and other agents in connection with this Agreement shall be the property of Sonoma Water. Sonoma Water shall be entitled to immediate possession of such documents upon completion of the work pursuant to this Agreement. Upon expiration or termination of this Agreement, Consultant shall promptly deliver to Sonoma Water all such documents, which have not already been provided to Sonoma Water in such form or format as Sonoma Water deems appropriate. Such documents shall be and will remain the property of Sonoma Water without restriction or limitation. Consultant may retain copies of the above described documents but agrees not to disclose or discuss any information gathered, discovered, or generated in any way through this Agreement without the express written permission of Sonoma Water.
- 13.11. *Nondisclosure of Confidential Information:* While doing the work required by this Agreement, Consultant may have access to technical information and materials pertaining to Sonoma Water's IT Network Design, including but not limited to information regarding Sonoma Water's IP addressing, file structures, user groups, wireless access points, business network, SCADA programs, make/model of network equipment, security information, and network software. ("Confidential Information"). The Confidential Information may include confidential or proprietary information or trade secrets exempt from disclosure under provisions of the California Public Records Act. In consideration of disclosure by Sonoma Water of Confidential Information to Consultant,

Consultant and its agents shall hold any material or information designated by Sonoma Water as Confidential in strict confidence and shall not disclose it or otherwise make it available, in any form or matter whatsoever, to any person or entity without the prior written consent of Sonoma Water, except as may be ordered by a court of law. Immediately upon receipt of any request or demand for disclosure of any Confidential Information within the scope of this Agreement, Consultant shall give Sonoma Water written notice and a copy of the request and the time period, if any, within which Consultant is required to respond to the request. Upon termination of this Agreement, Consultant shall return Confidential Information in its possession, including copies, to Sonoma Water. Consultant's obligation to maintain material and information designated as Confidential in strict confidence shall survive completion of work under this Agreement and termination of this Agreement and, as provided for in Paragraph 13.10, Consultant agrees not to disclose or discuss any information gathered, discovered, or generated in any way through this Agreement without the express written permission of Sonoma Water.

13.12. *Zone Liability:* The term "Zone" or "Zones" as used in this Paragraph 13.12 shall mean any applicable Sanitation Zone or Flood Protection Zone, as described in Recital C and Recital D of this Agreement. To the extent any work under this agreements relates to Zone activities, Consultant shall be paid exclusively from Zone funds. Consultant agrees that Consultant shall make no claim for compensation for Consultant's services against other funds available to Sonoma County Water Agency and Consultant expressly waives any right to be compensated from other funds available to Sonoma County Water Agency. In addition, Consultant acknowledges that West's Annotated California Codes Water Code Appendix Chapter 53-8 provides that certain judgments or claims against Sonoma County Water Agency based on causes of action arising from Zone activities may be made only from funds of that those Zones.

13.13. *District Liability:* Districts are separate legal entities from Sonoma County Water Agency, operated under contract by Sonoma County Water Agency. To the extent any work under this Agreement relates to District activities, Consultant shall be paid exclusively from District funds. Consultant agrees that it shall make no claim for compensation for Consultant's services against Sonoma County Water Agency funds and expressly waives any right to be compensated from other funds available to Sonoma County Water Agency.

14. DEMAND FOR ASSURANCE

14.1. Each party to this Agreement undertakes the obligation that the other's expectation of receiving due performance will not be impaired. When reasonable grounds for insecurity arise with respect to the performance of either party, the other may in writing demand adequate assurance of due performance and until such assurance is received may, if commercially reasonable, suspend any performance for which the agreed return has not been received.

“Commercially reasonable” includes not only the conduct of a party with respect to performance under this Agreement, but also conduct with respect to other agreements with parties to this Agreement or others. After receipt of a justified demand, failure to provide within a reasonable time, but not exceeding thirty (30) days, such assurance of due performance as is adequate under the circumstances of the particular case is a repudiation of this Agreement. Acceptance of any improper delivery, service, or payment does not prejudice the aggrieved party's right to demand adequate assurance of future performance. Nothing in this Article 14 limits Sonoma Water's right to terminate this Agreement pursuant to Article 7 (Termination).

15. ASSIGNMENT AND DELEGATION

- 15.1. *Consent:* Neither party hereto shall assign, delegate, sublet, or transfer any interest in or duty under this Agreement without the prior written consent of the other, and no such transfer shall be of any force or effect whatsoever unless and until the other party shall have so consented.
- 15.2. *Subcontracts:* Notwithstanding the foregoing, Consultant may enter into subcontracts with the subconsultants specifically identified herein. If no subconsultants are listed, then no subconsultants will be utilized in the performance of the work specified in this Agreement.
- 15.3. *Change of Subcontractors or Subconsultants:* If, after execution of the Agreement, parties agree that subconsultants not listed in Paragraph 15.2 will be utilized, Consultant may enter into subcontracts with subconsultants to perform other specific duties pursuant to the provisions of this Paragraph 15.3. The following provisions apply to any subcontract entered into by Consultant other than those listed in Paragraph 15.2:
- a. Prior to entering into any contract with subconsultant, Consultant shall obtain Sonoma Water approval of subconsultant.
 - b. All agreements with subconsultants shall (a) contain indemnity requirements in favor of Sonoma Water in substantially the same form as that contained in Article 8 (Indemnification), (b) contain language that the subconsultant may be terminated with or without cause upon reasonable written notice, and (c) prohibit the assignment or delegation of work under the agreement to any third party.
- 15.4. *Summary of Subconsultants' Work:* Consultant shall provide Sonoma Water with a summary of work performed by subconsultants with each invoice submitted under Paragraph 5.3. Such summary shall identify the individuals performing work on behalf of subconsultants and the total amount paid to subconsultant, broken down by the tasks listed in the Scope of Work.

16. METHOD AND PLACE OF GIVING NOTICE, SUBMITTING BILLS, AND MAKING PAYMENTS

- 16.1. *Method of Delivery:* All notices, bills, and payments shall be made in writing and shall be given by personal delivery, U.S. Mail, courier service, or electronic means. Notices, bills, and payments shall be addressed as specified in Paragraph 4.2.
- 16.2. *Receipt:* When a notice, bill, or payment is given by a generally recognized overnight courier service, the notice, bill, or payment shall be deemed received on the next business day. When a copy of a notice, bill, or payment is sent by electronic means, the notice, bill, or payment shall be deemed received upon transmission as long as (1) the original copy of the notice, bill, or payment is deposited in the U.S. mail and postmarked on the date of the electronic transmission (for a payment, on or before the due date), (2) the sender has a written confirmation of the electronic transmission, and (3) the electronic transmission is transmitted before 5 p.m. (recipient's time). In all other instances, notices, bills, and payments shall be effective upon receipt by the recipient. Changes may be made in the names and addresses of the person to whom notices are to be given by giving notice pursuant to this Article 16.

17. MISCELLANEOUS PROVISIONS

- 17.1. *No Bottled Water:* In accordance with Sonoma Water Board of Directors Resolution No. 09-0920, dated September 29, 2009, no Sonoma Water funding shall be used to purchase single-serving, disposable water bottles for use in Sonoma Water facilities or at Sonoma Water-sponsored events. This restriction shall not apply when potable water is not available.
- 17.2. *No Waiver of Breach:* The waiver by Sonoma Water of any breach of any term or promise contained in this Agreement shall not be deemed to be a waiver of such term or promise or any subsequent breach of the same or any other term or promise contained in this Agreement.
- 17.3. *Construction:* To the fullest extent allowed by law, the provisions of this Agreement shall be construed and given effect in a manner that avoids any violation of statute, ordinance, regulation, or law. The parties covenant and agree that in the event that any provision of this Agreement is held by a court of competent jurisdiction to be invalid, void, or unenforceable, the remainder of the provisions hereof shall remain in full force and effect and shall in no way be affected, impaired, or invalidated thereby. Consultant and Sonoma Water acknowledge that they have each contributed to the making of this Agreement and that, in the event of a dispute over the interpretation of this Agreement, the language of the Agreement will not be construed against one party in favor of the other. Consultant and Sonoma Water acknowledge that they have each had an adequate opportunity to consult with counsel in the negotiation and preparation of this Agreement.

- 17.4. *Consent:* Wherever in this Agreement the consent or approval of one party is required to an act of the other party, such consent or approval shall not be unreasonably withheld or delayed.
- 17.5. *No Third-Party Beneficiaries:* Except as provided in Article 8 (Indemnification), nothing contained in this Agreement shall be construed to create and the parties do not intend to create any rights in third parties.
- 17.6. *Applicable Law and Forum:* This Agreement shall be construed and interpreted according to the substantive law of California, regardless of the law of conflicts to the contrary in any jurisdiction. Any action to enforce the terms of this Agreement or for the breach thereof shall be brought and tried in Santa Rosa or in the forum nearest to the City of Santa Rosa, in the County of Sonoma.
- 17.7. *Captions:* The captions in this Agreement are solely for convenience of reference. They are not a part of this Agreement and shall have no effect on its construction or interpretation.
- 17.8. *Merger:* This writing is intended both as the final expression of the Agreement between the parties hereto with respect to the included terms and as a complete and exclusive statement of the terms of the Agreement, pursuant to Code of Civil Procedure section 1856. Each Party acknowledges that, in entering into this Agreement, it has not relied on any representation or undertaking, whether oral or in writing, other than those which are expressly set forth in this Agreement. No modification of this Agreement shall be effective unless and until such modification is evidenced by a writing signed by both parties.
- 17.9. *Survival of Terms:* All express representations, waivers, indemnifications, and limitations of liability included in this Agreement will survive its completion or termination for any reason.
- 17.10. *Time of Essence:* Time is and shall be of the essence of this Agreement and every provision hereof.

/

/

/

/

/

/

/

/

/

IN WITNESS WHEREOF, the parties hereto have executed this Agreement as of the date last signed by the parties to the Agreement.

Reviewed as to funds:

TW 16/17-121

By: _____
Sonoma County Water Agency
Division Manager - Administrative
Services

Approved as to form:

By: _____
Adam Brand, Deputy County Counsel

Insurance Documentation is on file with
Sonoma Water

Date/TW Initials: 9/27/18 JES

**Sonoma County Water Agency, Occidental
County Sanitation District, Russian River
County Sanitation District, Sonoma Valley
County Sanitation District, and South Park
County Sanitation District**

CH2M HILL Engineers, Inc., a Delaware
corporation

By: _____
Grant Davis
General Manager
Authorized per Sonoma County Water
Agency's Board of Directors Action on
November 13, 2018

By: _____

(Please print name here)

Title: _____

Date: _____

Date: _____

Exhibit A

Agreement Memorandum No. _____

TW 16/17-121

Consultant shall perform the services as outlined in Exhibit B (Scope of Work) of the Agreement and as modified below, if applicable, within the times or by the dates provided for herein.

A. Date of Initiation Conference:	
B. Project Manager Name:	
C. Project Manager Phone:	
D. Project Manager E-mail:	
E. Project Name:	
F. Project Location	
G. Project-Activity Code:	
H. Schedule for receipt of deliverables: Draft Report Due: Final Report Due:	
I. Not-to-exceed amount for this Agreement Memorandum:	
J. List of key personnel or authorized subcontractors, if applicable:	
K. Modifications to Exhibit B (Scope of Work), additional requirements, or attach additional sheet:	

CH2M HILL Engineers, Inc.

By: _____

Title: _____

Date: _____

Sonoma Water copies to:
Accounting and Records
Joan Hultberg
Jake Spaulding

- Sonoma County Water Agency**
- Choose one--- **County Sanitation District**

Reviewed by Project Manager:

By: _____

By: _____
Eric Wilhelm, Agreement Administrator

Date: _____

Exhibit B

Scope of Work

1. TASKS

- 1.1. Requested services may include, but are not limited to, the following:
 - a. Provide SCADA drawings, updates, designs, and field modifications, including user manuals, to facilitate operational changes to Water Agency equipment.
 - b. Perform maintenance, repair, modification, and upgrades to existing equipment.
 - c. Conduct design review of capital improvement drawings and specifications and related construction projects.
 - d. Provide programming and design for new equipment.
 - e. Provide procedural documentation and training personnel on system changes and new equipment.

2. REVIEW AND ACCEPTANCE OF WORK PRODUCTS

- 2.1. First Draft: Prepare each work product in draft form and submit to Sonoma Water for review and approval in accordance with the date listed for the deliverable in the applicable Agreement Memorandum. Sonoma Water will return 1 copy of the draft work product to Consultant with comments or approval in writing.
- 2.2. Subsequent Draft(s): If Sonoma Water requests revisions, revise the draft work deliverable and resubmit 2 copies of the draft work deliverable for Sonoma Water approval.
- 2.3. Final: Following Sonoma Water approval and prior to Sonoma Water's acceptance of work under this Agreement, submit each final approved work deliverable to Sonoma Water in accordance with the date listed for the deliverable in the applicable Agreement Memorandum.

3. DELIVERABLES

- 3.1. Submit one electronic copy in PDF format (emailed, on CD, or via internet) of each final deliverable to Sonoma Water.
- 3.2. Comply with requirements of Article 12 (Content Online Accessibility).

Exhibit C

Schedule of Rates

HOURLY BILLING RATES				
Title	2018	2019	2020	2021
Principal Technologist* / Principal Project Manager	\$240	\$246	\$252	\$258
Sr. Technologist* / Sr. Project Manager	\$225	\$231	\$236	\$242
Engineer Specialist* / Project Manager	\$210	\$215	\$221	\$226
Project Engineer*	\$195	\$200	\$205	\$210
Associate Engineer*	\$178	\$182	\$187	\$192
Staff Engineer 2*	\$161	\$165	\$168	\$172
Staff Engineer 1*	\$145	\$149	\$152	\$156
Engineering / Environmental Tech 5	\$155	\$159	\$163	\$167
Engineering / Environmental Tech 4	\$140	\$144	\$147	\$150
Engineering / Environmental Tech 3	\$125	\$128	\$131	\$134
Engineering / Environmental Tech 2	\$112	\$115	\$118	\$121
Engineering / Environmental Tech 1	\$100	\$103	\$105	\$108
Office / Clerical / Accounting	\$90	\$92	\$95	\$97
EXPENSES				
Item	Cost			
Copies	At cost			
Postage	At cost			
Overnight mail	At cost			
Mileage for personal car	Current IRS rate			

* Includes engineering, consulting, planner, scientist, and systems integration classifications

Exhibit D

Insurance Requirements

With respect to performance of work under this Agreement, Consultant shall maintain and shall require all of its subcontractors, consultants, and other agents to maintain insurance as described below unless such insurance has been expressly waived by the attachment of a *Waiver of Insurance Requirements*. Any requirement for insurance to be maintained after completion of the work shall survive this Agreement.

Sonoma Water reserves the right to review any and all of the required insurance policies and/or endorsements, but has no obligation to do so. Failure to demand evidence of full compliance with the insurance requirements set forth in this Agreement or failure to identify any insurance deficiency shall not relieve Consultant from, nor be construed or deemed a waiver of, its obligation to maintain the required insurance at all times during the performance of this Agreement.

1. INSURANCE

- 1.1. Workers Compensation and Employers Liability Insurance
 - a. Required if Consultant has employees as defined by the Labor Code of the State of California.
 - b. If Consultant currently has no employees as defined by the Labor Code of the State of California, Consultant agrees to obtain the above-specified Workers Compensation and Employers' Liability insurance should employees be engaged during the term of this Agreement or any extensions of the term.
- 1.2. General Liability Insurance
 - a. Commercial General Liability Insurance on a standard occurrence form, no less broad than Insurance Services Office (ISO) form CG 00 01.
 - b. Minimum Limits: \$1,000,000 per Occurrence; \$2,000,000 General Aggregate; \$2,000,000 Products/Completed Operations Aggregate. The required limits may be provided by a combination of General Liability Insurance and Commercial Excess or Commercial Umbrella Liability Insurance. If Consultant maintains higher limits than the specified minimum limits, Sonoma Water requires and shall be entitled to coverage for the higher limits maintained by Consultant.
 - c. Any deductible or self-insured retention shall be shown on the Certificate of Insurance. If the deductible or self-insured retention exceeds \$25,000 it must be approved in advance by Sonoma Water. Consultant is responsible for any deductible or self-insured retention and shall fund it upon Sonoma Water's written request, regardless of whether Consultant has a claim against the insurance or is named as a party in any action involving Sonoma Water.

- d. Sonoma County Water Agency, Occidental County Sanitation District, Russian River County Sanitation District, Sonoma Valley County Sanitation District, and South Park County Sanitation District, their officers, agents, and employees, shall be endorsed as additional insureds for liability arising out of operations by or on behalf of the Consultant in the performance of this Agreement.
- e. The insurance provided to the additional insureds shall be primary to, and non-contributory with, any insurance or self-insurance program maintained by them.
- f. The policy definition of “insured contract” shall include assumptions of liability arising out of both ongoing operations and the products-completed operations hazard (broad form contractual liability coverage including the “f” definition of insured contract in Insurance Services Office form CG 00 01, or equivalent).
- g. The policy shall cover inter-insured suits between the additional insureds and Consultant and include a “separation of insureds” or “severability” clause which treats each insured separately.
- h. Required Evidence of Insurance:
 - i. Copy of the additional insured endorsement or policy language granting additional insured status, and
 - ii. Certificate of Insurance.

1.3. Automobile Liability Insurance

- a. Minimum Limit: \$1,000,000 combined single limit per accident. The required limit may be provided by a combination of Automobile Liability Insurance and Commercial Excess or Commercial Umbrella Liability Insurance.
- b. Insurance shall cover all owned autos. If Consultant currently owns no autos, Consultant agrees to obtain such insurance should any autos be acquired during the term of this Agreement or any extensions of the term.
- c. Insurance shall cover hired and non-owned autos.
- d. Required Evidence of Insurance: Certificate of Insurance.

1.4. Professional Liability/Errors and Omissions Insurance

- a. Minimum Limit: \$1,000,000 per claim or per occurrence; \$1,000,000 annual aggregate.
- b. Any deductible or self-insured retention shall be shown on the Certificate of Insurance. If the deductible or self-insured retention exceeds \$25,000 it must be approved in advance by Sonoma Water.
- c. If Consultant’s services include: (1) programming, customization, or maintenance of software: or (2) access to individuals’ private, personally identifiable information, the insurance shall cover:
 - i. Breach of privacy; breach of data; programming errors, failure of work to meet contracted standards, and unauthorized access; and

- ii. Claims against Consultant arising from the negligence of Consultant, Consultant's employees and Consultant's subcontractors.
 - d. If the insurance is on a Claims-Made basis, the retroactive date shall be no later than the commencement of the work.
 - e. Coverage applicable to the work performed under this Agreement shall be continued for two (2) years after completion of the work. Such continuation coverage may be provided by one of the following: (1) renewal of the existing policy; (2) an extended reporting period endorsement; or (3) replacement insurance with a retroactive date no later than the commencement of the work under this Agreement.
 - f. Required Evidence of Insurance: Certificate of Insurance specifying the limits and the claims-made retroactive date.
- 1.5. Standards for Insurance Companies
- a. Insurers, other than the California State Compensation Insurance Fund, shall have an A.M. Best's rating of at least A:VII.
- 1.6. Documentation
- a. The Certificate of Insurance must include the following reference: TW 16/17-121.
 - b. All required Evidence of Insurance shall be submitted prior to the execution of this Agreement. Consultant agrees to maintain current Evidence of Insurance on file with Sonoma Water for the entire term of this Agreement and any additional periods if specified in Sections 1.1, 1.2, 1.3, or 1.4, or above.
 - c. The name and address for mailing Additional Insured endorsements and Certificates of Insurance is: Sonoma County Water Agency, Occidental County Sanitation District, Russian River County Sanitation District, Sonoma Valley County Sanitation District, and South Park County Sanitation District, c/o Sonoma County Water Agency, 404 Aviation Boulevard, Santa Rosa, CA 95403-9019.
 - d. Required Evidence of Insurance shall be submitted for any renewal or replacement of a policy that already exists, at least ten (10) days before expiration or other termination of the existing policy.
 - e. Consultant shall provide immediate written notice if: (1) any of the required insurance policies is terminated; (2) the limits of any of the required policies are reduced; or (3) the deductible or self-insured retention is increased.
- 1.7. Policy Obligations
- a. Consultant's indemnity and other obligations shall not be limited by the foregoing insurance requirements.

1.8. Material Breach

- a. If Consultant fails to maintain insurance which is required pursuant to this Agreement, it shall be deemed a material breach of this Agreement. Sonoma Water, at its sole option, may terminate this Agreement and obtain damages from Consultant resulting from said breach. Alternatively, Sonoma Water may purchase the required insurance, and without further notice to Consultant, Sonoma Water may deduct from sums due to Consultant any premium costs advanced by Sonoma Water for such insurance. These remedies shall be in addition to any other remedies available to Sonoma Water.



CERTIFICATE OF LIABILITY INSURANCE

DATE (MM/DD/YYYY)
09/12/2018

THIS CERTIFICATE IS ISSUED AS A MATTER OF INFORMATION ONLY AND CONFERS NO RIGHTS UPON THE CERTIFICATE HOLDER. THIS CERTIFICATE DOES NOT AFFIRMATIVELY OR NEGATIVELY AMEND, EXTEND OR ALTER THE COVERAGE AFFORDED BY THE POLICIES BELOW. THIS CERTIFICATE OF INSURANCE DOES NOT CONSTITUTE A CONTRACT BETWEEN THE ISSUING INSURER(S), AUTHORIZED REPRESENTATIVE OR PRODUCER, AND THE CERTIFICATE HOLDER.

IMPORTANT: If the certificate holder is an ADDITIONAL INSURED, the policy(ies) must have ADDITIONAL INSURED provisions or be endorsed. If SUBROGATION IS WAIVED, subject to the terms and conditions of the policy, certain policies may require an endorsement. A statement on this certificate does not confer rights to the certificate holder in lieu of such endorsement(s).

PRODUCER LIC #0437153 Marsh Risk & Insurance Services CIRTS_Support@jacobs.com 633 W. Fifth Street Los Angeles, CA 90071	1-212-948-1306	CONTACT NAME: PHONE (A/C, No. Ext): E-MAIL ADDRESS:	FAX (A/C, No): 1-212-948-1306
INSURED CH2M HILL ENGINEERS, INC. 9191 South Jamaica Street Englewood, CO 80112-5946		INSURER(S) AFFORDING COVERAGE INSURER A: ACE AMER INS CO INSURER B: INSURER C: INSURER D: INSURER E: INSURER F:	
		NAIC # 22667	

COVERAGES

CERTIFICATE NUMBER: 53923960

REVISION NUMBER:

THIS IS TO CERTIFY THAT THE POLICIES OF INSURANCE LISTED BELOW HAVE BEEN ISSUED TO THE INSURED NAMED ABOVE FOR THE POLICY PERIOD INDICATED. NOTWITHSTANDING ANY REQUIREMENT, TERM OR CONDITION OF ANY CONTRACT OR OTHER DOCUMENT WITH RESPECT TO WHICH THIS CERTIFICATE MAY BE ISSUED OR MAY PERTAIN, THE INSURANCE AFFORDED BY THE POLICIES DESCRIBED HEREIN IS SUBJECT TO ALL THE TERMS, EXCLUSIONS AND CONDITIONS OF SUCH POLICIES. LIMITS SHOWN MAY HAVE BEEN REDUCED BY PAID CLAIMS.

INSR LTR	TYPE OF INSURANCE	ADDL INSD	SUBR WVD	POLICY NUMBER	POLICY EFF (MM/DD/YYYY)	POLICY EXP (MM/DD/YYYY)	LIMITS	
A	<input checked="" type="checkbox"/> COMMERCIAL GENERAL LIABILITY <input type="checkbox"/> CLAIMS-MADE <input checked="" type="checkbox"/> OCCUR <input checked="" type="checkbox"/> CONTRACTUAL LIABILITY GEN'L AGGREGATE LIMIT APPLIES PER: <input type="checkbox"/> POLICY <input type="checkbox"/> PRO-JECT <input type="checkbox"/> LOC <input type="checkbox"/> OTHER:			HDO G71096750	07/01/18	07/01/19	EACH OCCURRENCE	\$ 1,000,000
							DAMAGE TO RENTED PREMISES (Ea occurrence)	\$ 500,000
							MED EXP (Any one person)	\$ 5,000
							PERSONAL & ADV INJURY	\$ 1,000,000
							GENERAL AGGREGATE	\$ 2,000,000
							PRODUCTS - COMP/OP AGG	\$ 2,000,000
								\$
A	<input checked="" type="checkbox"/> AUTOMOBILE LIABILITY <input checked="" type="checkbox"/> ANY AUTO <input type="checkbox"/> OWNED AUTOS ONLY <input type="checkbox"/> SCHEDULED AUTOS <input type="checkbox"/> HIRED AUTOS ONLY <input type="checkbox"/> NON-OWNED AUTOS ONLY			ISA H25158684	07/01/18	07/01/19	COMBINED SINGLE LIMIT (Ea accident)	\$ 1,000,000
							BODILY INJURY (Per person)	\$
							BODILY INJURY (Per accident)	\$
							PROPERTY DAMAGE (Per accident)	\$
								\$
	<input type="checkbox"/> UMBRELLA LIAB <input type="checkbox"/> OCCUR <input type="checkbox"/> EXCESS LIAB <input type="checkbox"/> CLAIMS-MADE <input type="checkbox"/> DED <input type="checkbox"/> RETENTION \$						EACH OCCURRENCE	\$
							AGGREGATE	\$
								\$
A	<input checked="" type="checkbox"/> WORKERS COMPENSATION AND EMPLOYERS' LIABILITY <input type="checkbox"/> ANY PROPRIETOR/PARTNER/EXECUTIVE OFFICER/MEMBER EXCLUDED? (Mandatory in NH) If yes, describe under DESCRIPTION OF OPERATIONS below			WLR C6479033A (AOS)	07/01/18	07/01/19	<input checked="" type="checkbox"/> PER STATUTE <input type="checkbox"/> OTHER	
A			N/A	WCU C64789533 (LA, OH, TX)	07/01/18	07/01/19	E.L. EACH ACCIDENT	\$ 1,000,000
A				SCF C64789570 (WI)	07/01/18	07/01/19	E.L. DISEASE - EA EMPLOYEE	\$ 1,000,000
							E.L. DISEASE - POLICY LIMIT	\$ 1,000,000
A	<input checked="" type="checkbox"/> PROFESSIONAL LIABILITY "CLAIMS MADE"			EON G21655065 009	07/01/18	07/01/19	PER CLAIM/PER AGG	1,000,000
							AGGREGATE	
							DEFENSE INCLUDED	

DESCRIPTION OF OPERATIONS / LOCATIONS / VEHICLES (ACORD 101, Additional Remarks Schedule, may be attached if more space is required)

PROJECT MGR: Jerry Dehn. CONTRACT MGR: Karen Anuszczyk. RE: AS-Needed SCADA System Support and Related Services. CONTRACT END DATE: 12/30/2021. PROJECT NUMBER: 699206. SECTOR: Public. *\$2,250,000 SIR FOR STATES OF: LA, OH, TX. Sonoma County Water Agency, Occidental County Sanitation District, Russian River County Sanitation District, Sonoma Valley County Sanitation District, and South Park County Sanitation District, their officers, agents, and employees are added as an additional insured for general liability as respects the negligence of the insured in the performance of insured's services to cert holder under contract for captioned work. Coverage is primary and certificate holder's insurance is excess and non-contributory. General Liability coverage includes the severability of interests/Cross Suits

CERTIFICATE HOLDER

Sonoma County Water Agency

404 Aviation Blvd

Santa Rosa, CA 95403

USA

CANCELLATION

SHOULD ANY OF THE ABOVE DESCRIBED POLICIES BE CANCELLED BEFORE THE EXPIRATION DATE THEREOF, NOTICE WILL BE DELIVERED IN ACCORDANCE WITH THE POLICY PROVISIONS.

AUTHORIZED REPRESENTATIVE

© 1988-2015 ACORD CORPORATION. All rights reserved.

ACORD 25 (2016/03)

The ACORD name and logo are registered marks of ACORD

nyumdo_newgalaxy
53923960

SUPPLEMENT TO CERTIFICATE OF INSURANCE

DATE
09/12/2018

NAME OF INSURED: CH2M HILL ENGINEERS, INC.

Liability provision in favor of the holder. *THIS IS A SAMPLE CERTIFICATE ONLY*. THE ACTUAL CERTIFICATE FOR THE PROPOSED PROJECT WILL COMPLY WITH THE TERMS AND CONDITIONS NEGOTIATED IN THE FINAL CONTRACT, CONSISTENT WITH POLICY TERMS AND CONDITIONS.

ADDITIONAL INSURED - AUTOMATIC STATUS

Named Insured Jacobs Engineering Group Inc.			Endorsement Number 2
Policy Symbol HDO	Policy Number G71096750	Policy Period 07/01/2018 TO 07/01/2019	Effective Date of Endorsement
Issued By (Name of Insurance Company) ACE American Insurance Company			

THIS ENDORSEMENT CHANGES THE POLICY. PLEASE READ IT CAREFULLY.

THIS ENDORSEMENT MODIFIES INSURANCE PROVIDED UNDER THE FOLLOWING:

COMMERCIAL GENERAL LIABILITY COVERAGE FORM

SCHEDULE

Name of Person or Organization: Any person or organization for whom any Named Insured is required by written contract or agreement to provide insurance, entered into prior to the loss, where such written contract or agreement does not expressly identify a particular Insurance Service Organization Form to be applied to their additional insured status.

Who Is An Insured (Section II) includes as an additional insured the person or organization shown in the Schedule, but the insurance shall not exceed the scope of coverage and/or limits of this policy. Notwithstanding the foregoing sentence, in no event shall the insurance provided such additional insured exceed the scope of the coverage and/or limits required by said contract or agreement; and, if such additional insured's scope of coverage is not expressly stated in such contract or agreement, then such coverage is limited to the additional insured's vicarious liability to the extent directly caused by the Named Insured's negligence during the Named Insured's ongoing operations. This insurance shall be primary insurance to the extent required by said contract or agreement, and any other insurance or self-insurance maintained by such person or organization shall be noncontributory with the insurance provided hereunder to the extent specified in said contract agreement.

Where the contract or agreement provides that the additional insured's scope of coverage is for the Named Insured's indemnity obligations under such contract or agreement, then such coverage shall be limited to the extent such indemnity obligations are enforceable under applicable law.

Notwithstanding the foregoing sentence, in no event shall the insurance provided such additional insured exceed the scope of coverage required by said contract or agreement

Notwithstanding anything to the contrary, the coverage provided an additional insured under this endorsement shall be limited to the minimum coverage limits required to be provided by the Named Insured under the written contract or agreement.

ADDITIONAL INSURED - DESIGNATED PERSONS OR ORGANIZATIONS

Named Insured Jacobs Engineering Group Inc.			Endorsement Number 4
Policy Symbol ISA	Policy Number H25158684	Policy Period 07/01/2018 TO 07/01/2019	Effective Date of Endorsement
Issued By (Name of Insurance Company) ACE American Insurance Company			

THIS ENDORSEMENT CHANGES THE POLICY. PLEASE READ IT CAREFULLY.

THIS ENDORSEMENT MODIFIES INSURANCE PROVIDED UNDER THE FOLLOWING:

BUSINESS AUTO COVERAGE FORM

Additional Insured(s): Any person or organization whom you have agreed to include as an additional insured under a written contract, provided such contract was executed prior to the date of loss.-Project and/or Contract: All projects and/or contracts where you perform work for such additional insured pursuant to any such written contract.

A. For a covered "auto," Who Is Insured is amended to include as an "insured," the persons or organizations named in this endorsement. However, these persons or organizations are an "insured" only for "bodily injury" or "property damage" resulting from acts or omissions of:

1. You.
2. Any of your "employees" or agents.
3. Any person operating a covered "auto" with permission from you, any of your "employees" or agents.

B. The persons or organizations named in this endorsement are not liable for payment of your premium.

C. With respect to the insurance afforded to these additional insureds, the following applies:

If coverage provided to the additional insured is required by a contract or agreement, the most we will pay on behalf of the additional insured is the amount of insurance:

1. Required by the contract or agreement; or
 2. Available under the applicable Limits of Insurance shown in the Declarations;
- whichever is less.

If such additional insured's scope of coverage is not expressly stated in a contract or agreement, then such coverage is limited to the additional insured's vicarious liability to the extent directly caused by the Named Insured's negligence during the Named Insureds ongoing operations. This insurance shall be primary insurance to the extent required by said contract or agreement, and any other insurance or self-insurance maintained by such person or organization shall be noncontributory with the insurance provided hereunder to the extent specified in said contract agreement.

Where the contract or agreement provides that the additional insured's scope of coverage is for the named insured's indemnity obligations under such contract or agreement, then such coverage shall be limited to the extent such indemnity obligations are enforceable under applicable law.

NOTICE TO OTHERS ENDORSEMENT – SCHEDULE – EMAIL ONLY

Named Insured Jacobs Engineering Group Inc.			Endorsement Number 13
Policy Symbol HDO	Policy Number G71096750	Policy Period 07/01/2018 TO 07/01/2019	Effective Date of Endorsement
Issued By (Name of Insurance Company) ACE American Insurance Company			

Insert the policy number. The remainder of the information is to be completed only when this endorsement is issued subsequent to the preparation of the policy.

THIS ENDORSEMENT CHANGES THE POLICY. PLEASE READ IT CAREFULLY.

- A.** If we cancel the Policy prior to its expiration date by notice to you or the first Named Insured for any reason other than nonpayment of premium, we will endeavor, as set out below, to send written notice of cancellation, via such electronic notification as we determine, to the persons or organizations listed in the schedule that you or your representative provide or have provided to us (the "Schedule"). You or your representative must provide us with the e-mail address of such persons or organizations, and we will utilize such e-mail address that you or your representative provided to us on such Schedule.
- B.** The Schedule must be initially provided to us within 15 days after:
- i.** The beginning of the Policy period, if this endorsement is effective as of such date; or
 - ii.** This endorsement has been added to the Policy, if this endorsement is effective after the Policy period commences.
- C.** The Schedule must be in an electronic format that is acceptable to us; and must be accurate.
- D.** Our delivery of the notification as described in Paragraph A. of this endorsement will be based on the most recent Schedule in our records as of the date the notice of cancellation is mailed or delivered to the first Named Insured.
- E.** We will endeavor to send such notice to the e-mail address corresponding to each person or organization indicated in the Schedule at least 30 days prior to the cancellation date applicable to the Policy.
- F.** The notice referenced in this endorsement is intended only to be a courtesy notification to the person(s) or organization(s) named in the Schedule in the event of a pending cancellation of coverage. We have no legal obligation of any kind to any such person(s) or organization(s). Our failure to provide advance notification of cancellation to the person(s) or organization(s) shown in the Schedule shall impose no obligation or liability of any kind upon us, our agents or representatives, will not extend any Policy cancellation date and will not negate any cancellation of the Policy.
- G.** We are not responsible for verifying any information provided to us in any Schedule, nor are we responsible for any incorrect information that you or your representative provide to us. If you or your representative does not provide us with a Schedule, we have no responsibility for taking any action under this endorsement. In addition, if neither you nor your representative provides us with e-mail address information with respect to a particular person or organization, then we shall have no responsibility for taking action with regard to such person or entity under this endorsement.
- H.** We may arrange with your representative to send such notice in the event of any such cancellation.
- I.** You will cooperate with us in providing the Schedule, or in causing your representative to provide the Schedule.
- J.** This endorsement does not apply in the event that you cancel the Policy.

All other terms and conditions of the Policy remain unchanged.

A handwritten signature in black ink, appearing to be 'C. A. H.', written above a horizontal line.

Authorized Representative

NOTICE TO OTHERS ENDORSEMENT – SCHEDULE – EMAIL ONLY

Named Insured Jacobs Engineering Group Inc.			Endorsement Number 3
Policy Symbol ISA	Policy Number H25158684	Policy Period 07/01/2018 TO 07/01/2019	Effective Date of Endorsement
Issued By (Name of Insurance Company) ACE American Insurance Company			

Insert the policy number. The remainder of the information is to be completed only when this endorsement is issued subsequent to the preparation of the policy.

THIS ENDORSEMENT CHANGES THE POLICY. PLEASE READ IT CAREFULLY.

- A. If we cancel the Policy prior to its expiration date by notice to you or the first Named Insured for any reason other than nonpayment of premium, we will endeavor, as set out below, to send written notice of cancellation, via such electronic notification as we determine, to the persons or organizations listed in the schedule that you or your representative provide or have provided to us (the "Schedule"). You or your representative must provide us with the e-mail address of such persons or organizations, and we will utilize such e-mail address that you or your representative provided to us on such Schedule.
- B. The Schedule must be initially provided to us within 15 days after:
 - i. The beginning of the Policy period, if this endorsement is effective as of such date; or
 - ii. This endorsement has been added to the Policy, if this endorsement is effective after the Policy period commences.
- C. The Schedule must be in an electronic format that is acceptable to us; and must be accurate.
- D. Our delivery of the notification as described in Paragraph A. of this endorsement will be based on the most recent Schedule in our records as of the date the notice of cancellation is mailed or delivered to the first Named Insured.
- E. We will endeavor to send such notice to the e-mail address corresponding to each person or organization indicated in the Schedule at least 30 days prior to the cancellation date applicable to the Policy.
- F. The notice referenced in this endorsement is intended only to be a courtesy notification to the person(s) or organization(s) named in the Schedule in the event of a pending cancellation of coverage. We have no legal obligation of any kind to any such person(s) or organization(s). Our failure to provide advance notification of cancellation to the person(s) or organization(s) shown in the Schedule shall impose no obligation or liability of any kind upon us, our agents or representatives, will not extend any Policy cancellation date and will not negate any cancellation of the Policy.
- G. We are not responsible for verifying any information provided to us in any Schedule, nor are we responsible for any incorrect information that you or your representative provide to us. If you or your representative does not provide us with a Schedule, we have no responsibility for taking any action under this endorsement. In addition, if neither you nor your representative provides us with e-mail address information with respect to a particular person or organization, then we shall have no responsibility for taking action with regard to such person or entity under this endorsement.
- H. We may arrange with your representative to send such notice in the event of any such cancellation.
- I. You will cooperate with us in providing the Schedule, or in causing your representative to provide the Schedule.
- J. This endorsement does not apply in the event that you cancel the Policy.

All other terms and conditions of the Policy remain unchanged.

Authorized Representative

Workers' Compensation and Employers' Liability Policy

Named Insured JACOBS ENGINEERING GROUP INC. 600 WILSHIRE BOULEVARD, SUITE 1000 LOS ANGELES CA 90017	Endorsement Number
	Policy Number Symbol: WLR Number: C647033A
Policy Period 07-01-2018 TO 07-01-2019	Effective Date of Endorsement 07-01-2018
Issued By (Name of Insurance Company) ACE AMERICAN INSURANCE COMPANY	
Insert the policy number. The remainder of the information is to be completed only when this endorsement is issued subsequent to the preparation of the policy.	

NOTICE TO OTHERS ENDORSEMENT – SCHEDULE – EMAIL ONLY

- A. If we cancel this Policy prior to its expiration date by notice to you or the first Named insured for any reason other than nonpayment of premium, we will endeavor, as set out below, to send written notice of cancellation, via such electronic notification as we determine, to the persons or organizations listed in the schedule that you or your representative provide or have provided to us (the "Schedule"). You or your representative must provide us with the e-mail address of such persons or organizations, and we will utilize such e-mail address that you or your representative provided to us on such Schedule.
- B. The Schedule must be initially provided to us within 15 days after:
 - i. The beginning of the Policy period, if this endorsement is effective as of such date; or
 - ii. This endorsement has been added to the Policy, if this endorsement is effective after the Policy period commences.
- C. The Schedule must be in an electronic format that is acceptable to us; and must be accurate.
- D. Our delivery of the notification as described in Paragraph A. of this endorsement will be based on the most recent Schedule in our records as of the date the notice of cancellation is mailed or delivered to the first Named Insured.
- E. We will endeavor to send such notice to the e-mail address corresponding to each person or organization indicated in the Schedule at least 30 days prior to the cancellation date applicable to the Policy.
- F. The notice referenced in this endorsement is intended only to be a courtesy notification to the person(s) or organization(s) named in the Schedule in the event of a pending cancellation of coverage. We have no legal obligation of any kind to any such person(s) or organization(s). Our failure to provide advance notification of cancellation to the person(s) or organization(s) shown in the Schedule shall impose no obligation or liability of any kind upon us, our agents or representatives, will not extend any Policy cancellation date and will not negate any cancellation of the Policy.
- G. We are not responsible for verifying any information provided to us in any Schedule, nor are we responsible for any incorrect information that you or your representative provide to us. If you or your representative does not provide us with a Schedule, we have no responsibility for taking any action under this endorsement. In addition, if neither you nor your representative provides us with e-mail address information with respect to a particular person or organization, then we shall have no responsibility for taking action with regard to such person or entity under this endorsement.
- H. We may arrange with your representative to send such notice in the event of any such cancellation.
- I. You will cooperate with us in providing the Schedule, or in causing your representative to provide the Schedule.
- J. This endorsement does not apply in the event that you cancel the Policy.

All other terms and conditions of this Policy remain unchanged.

This Endorsement is not applicable in the states of AZ, FL, ID, ME, NC, NJ, NM, TX and WI.



Authorized Representative

THIS ENDORSEMENT CHANGES THE POLICY. PLEASE READ IT CAREFULLY.

Named Insured Jacobs Engineering Group Inc.			Endorsement Number 86
Policy Symbol EON	Policy Number G21655065 009	Policy Period 07/01/2018 to 07/01/2019	Effective Date of Endorsement 07/01/2018
Issued By (Name of Insurance Company) ACE American Insurance Company			

NOTICE TO OTHERS ENDORSEMENT – SCHEDULE

- A. If **We** cancel or non-renew the **Policy** prior to its expiration date by notice to **You** for any reason other than nonpayment of premium, **We** will endeavor, as set out below, to send written notice of cancellation or non-renewal via such electronic or other form of notification as **We** determine, to the persons or organizations listed in the schedule that **You** or **Your** representative provide or have provided to **Us** (the **Schedule**). **You** or **Your** representative must provide **Us** with both the physical and e-mail address of such persons or organizations, and **We** will utilize such e-mail address and/or physical address that **You** or **Your** representative provided to **Us** on such **Schedule**.
- B. The **Schedule** must be initially provided to **Us** within 30 days after:
- i. The beginning of the **Policy Period**, if this endorsement is effective as of such date; or
 - ii. This endorsement has been added to the **Policy**, if this endorsement is effective after the **Policy Period** commences.
- C. The **Schedule** must be in a format that is acceptable to **Us** and must be accurate.
- D. **Our** delivery of the notification as described in Paragraph A of this endorsement will be based on the most recent **Schedule** in **Our** records as of the date the notice of cancellation or non-renewal is mailed or delivered to **You**.
- E. **We** will endeavor to send or deliver such notice to the e-mail address or physical address corresponding to each person or organization indicated in the **Schedule** at least 30 days prior to the cancellation or non-renewal date applicable to the **Policy**.
- F. The notice referenced in this endorsement is intended only to be a courtesy notification to the person(s) or organization(s) named in the **Schedule** in the event of a pending cancellation or non-renewal of coverage. **We** have no legal obligation of any kind to any such person(s) or organization(s). **Our** failure to provide advance notification of cancellation or non-renewal to the person(s) or organization(s) shown in the **Schedule** shall impose no obligation or liability of any kind upon **Us**, **Our** agents or representatives, will not extend any **Policy** cancellation or non-renewal date and will not negate any cancellation or non-renewal of the **Policy**.
- G. **We** are not responsible for verifying any information provided to **Us** in any **Schedule**, nor are **We** responsible for any incorrect information that **You** or **Your** representative provide to **Us**. If **You** or **Your** representative does not provide **Us** with a **Schedule**, **We** have no responsibility for taking any action under this endorsement. In addition, if neither **You** nor **Your** representative provides **Us** with e-mail address and/or physical address information with respect to a particular person or organization, then **We** shall have no responsibility for taking action with regard to such person or entity under this endorsement.
- H. With respect to this endorsement **Our**, **Us** or **We** means the stock insurance company listed in the Declarations, and **You** or **Your** means the insured person or entity listed in Item 1 of the Declarations page.

All other terms and conditions of this **Policy** remain unchanged.

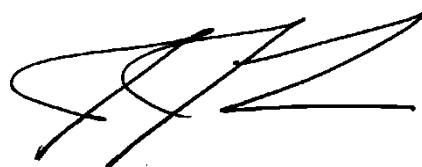

Authorized Representative



County of Sonoma Agenda Item Summary Report

Clerk of the Board
575 Administration Drive
Santa Rosa, CA 95403

Agenda Item Number: 7
(This Section for use by Clerk of the Board Only.)

To: Board of Supervisors and Board of Directors of Sonoma County Water Agency

Board Agenda Date: November 13, 2018

Vote Requirement: Majority

Department or Agency Name(s): Board Ad Hoc Committee for the Potter Valley Project

Staff Name and Phone Number:

James Gore (707) 565-3757
Lynda Hopkins (707) 565-2241

Supervisorial District(s):

All

Title: Resolution in Support of a Two-Basin Solution for the Future of the Potter Valley Project

Recommended Actions:

Adopt a Concurrent Resolution Supporting a Two-Basin Solution for the Future of the Potter Valley Project

Executive Summary:

Pacific Gas & Electric's (PG&E) Potter Valley Project (PVP or Project) is a hydroelectric facility that diverts Eel River water through a tunnel to a powerhouse in the Russian River watershed. After producing power, water is discharged from the powerhouse to the East Fork of the Russian River and then flows into Lake Mendocino. The current license for the Project issued by the Federal Energy Regulatory Commission (FERC) will expire in 2022, and PG&E must file for a new license by April 14, 2020. On May 10, 2018, PG&E sent a letter to the Eel-Russian River Commission publicly announcing its intention to auction the Project. PG&E has also announced its intention to continue with the relicensing while seeking a new owner for the Project. The Board Ad Hoc Committee for the Potter Valley Project recommends the Board of Supervisors and the Board of Directors of the Sonoma County Water Agency (Sonoma Water) adopt a concurrent resolution supporting a Two-Basin Solution for the future of the Project that protects fisheries and water supplies in both the Eel and Russian River Watersheds.

Discussion:

The Potter Valley Project, owned by PG&E, was constructed on the main stem of the Eel River in Mendocino County between 1905 and 1922 to generate hydroelectric power. The operation of the Project serves as an inter-basin transfer of water from the upper main stem of the Eel River basin in Lake County to the Russian River basin in Mendocino County. The Potter Valley Project began operation in 1908 with the completion of Cape Horn Dam, and then in 1922 Scott Dam was completed, forming Lake Pillsbury.

The Potter Valley Project diverts water from the Eel River through a tunnel into Potter Valley, located in the Russian River Watershed, to produce hydroelectric power. After generating power, the water that is not used by Potter Valley Irrigation District and other water rights holders flows down the East Fork Russian River into Lake Mendocino. Since the completion of Coyote Valley Dam in 1959, the water released from the Potter Valley Project has been impounded and stored in Lake Mendocino, providing water supply for multiple beneficial uses along the Russian River in Mendocino and Sonoma Counties to the Pacific Ocean.

The current PVP license expires in 2022. On April 6, 2017, PG&E began the relicensing process by filing a Notice of Intent (“NOI”) and Pre-Application Document (“PAD”). On May 10, 2018, PG&E sent a letter to the Eel-Russian River Commission publicly announcing its intention to auction the Project. PG&E has also announced its intention to continue with the relicensing while seeking a new owner for the Project. PG&E must file its application for a new license by April 14, 2020.

In 2017, Congressman Jared Huffman convened an ad hoc committee of interested parties to work toward a Two-Basin Solution for the future of the Project that addresses issues and concerns in both the Eel River and Russian River watersheds. The County of Sonoma and Sonoma Water have been participating in the ad hoc committee convened by Congressman Huffman, and have been working with regional stakeholders, including PG&E, to plan for the future of the Project that protects fisheries and water supply in both the Eel and Russian River Watersheds.

The Board Ad Hoc Committee recommends the Board of Supervisors and the Board of Directors of the Sonoma County Water Agency adopt a concurrent resolution affirming (1) the Boards’ support for the concept of a Two-Basin Solution; (2) the Boards’ support for a future of the Potter Valley Project that protects fisheries and water supplies in both the Eel and Russian River watersheds; (3) that the Potter Valley Project is a project of regional importance, and in order to achieve a Two-Basin Solution regional stakeholders will need to work together to implement a regional solution; and (4) that the County of Sonoma and the Sonoma County Water Agency are willing to work with regional partners and stakeholders in furtherance of a Two-Basin Solution.

Prior Board Actions:

None

Strategic Plan Alignment Goal 2: Economic and Environmental Stewardship

Fiscal Summary			
Expenditures	FY 18-19 Adopted	FY 19-20 Projected	FY 20-21 Projected
Budgeted Expenses	-0-	-0-	-0-
Additional Appropriation Requested	-0-		
Total Expenditures	-0-	-0-	-0-
Funding Sources			
General Fund/WA GF	-0-	-0-	-0-
State/Federal	-0-	-0-	-0-
Fees/Other	-0-	-0-	-0-
Use of Fund Balance	-0-	-0-	-0-
Contingencies	-0-	-0-	-0-
Total Sources	-0-	-0-	-0-
Narrative Explanation of Fiscal Impacts:			
N/A			
Staffing Impacts			
Position Title (Payroll Classification)	Monthly Salary Range (A – I Step)	Additions (Number)	Deletions (Number)
N/A	N/A	N/A	N/A
N/A	N/A	N/A	N/A
Narrative Explanation of Staffing Impacts (If Required):			
N/A			
Attachments:			
Resolution			
Related Items "On File" with the Clerk of the Board:			
N/A			



County of Sonoma

State of California

Date: November 13, 2018

Item Number: _____

Resolution Number: _____



4/5 Vote Required

Concurrent Resolution Of The Board Of Supervisors Of The County Of Sonoma, State Of California, And The Board Of Directors Of The Sonoma County Water Agency Regarding The Future Of The Potter Valley Project

Whereas, the Potter Valley Project owned by Pacific Gas & Electric (PG&E) was constructed on the main stem of the Eel River in Mendocino County between 1905 and 1922 to generate hydroelectric power, and through its operation serves as an inter-basin transfer of water from the upper main stem of the Eel River basin in Lake County to the Russian River basin in Mendocino County; and

Whereas, the Potter Valley Project began operation in 1908 with the completion of Cape Horn Dam which impounded water in Van Arsdale reservoir, initially operating only as a 'run of the river' diversion. This was changed in 1922 when Scott Dam was completed, thereby forming Lake Pillsbury, which allowed winter rains and snow melt to be impounded and stored for release in the late spring, summer and fall, creating a year round source of water supply to the Eel and Russian River watersheds; and

Whereas, releases of stored water from Lake Pillsbury assure that releases below Cape Horn Dam exceed naturally occurring flow rates, thereby benefiting fisheries in the Eel River as well as other downstream beneficial uses; and

Whereas, the Potter Valley Project diverts water from the Eel River through a tunnel into Potter Valley, located in the Russian River watershed, to produce hydroelectric power. After generating power, the water that is not used by Potter Valley Irrigation District and other water rights holders flows down the East Fork Russian River into Lake Mendocino; and

Whereas, since the completion of Coyote Valley Dam in 1959, the water released from the Potter Valley Project has been impounded and stored in Lake Mendocino, providing water supply for multiple beneficial uses along the Russian River in Mendocino and Sonoma Counties to the Pacific Ocean.

Whereas, stored water from both Lake Pillsbury and Lake Mendocino support beneficial uses that are critical to the environmental and economic well-being of the counties of Humboldt, Lake, Mendocino, Sonoma and Marin. In addition to generating power, this stored water also provides water supply for irrigation of crops, domestic, municipal and industrial water supplies, recreational and environmental benefits, including fisheries for Humboldt, Lake, Mendocino, Sonoma and Marin Counties, groundwater recharge and water for riparian vegetation; and

Resolution #

Date:

Page 2

Whereas, the Potter Valley Project provides the water supply for communities all along the Russian River in Mendocino and Sonoma Counties, including Ukiah, Hopland, Cloverdale, Geyserville and Healdsburg, thereby supporting the agricultural economy, the quality of life, and the health of the Russian River's aquatic resources, including three species of salmonids listed as endangered or threatened, and has provided environmental benefits in the Russian River that are required under the federal Endangered Species Act; and

Whereas, between 1922 and 2006, diversions from the Eel River into the Russian River through the Potter Valley Project averaged over 150,000 acre-feet per year. Since 2006, Eel River diversions have averaged 72,000 acre-feet per year, and diversions in several years were much lower than this average due to the 2011-2017 drought and PG&E's need to reduce flows through the Potter Valley Project while it was completing major repairs; and

Whereas, the amount of water flowing from the Potter Valley Project into Lake Mendocino has dropped by almost 60% since 2006; Potter Valley Project diversions are even more critical for water supplies and migrating fish in the Russian River watershed; and

Whereas, in 2013, the State Water Resources Control Board required the Sonoma County Water Agency to undertake a water supply reliability study of Lake Mendocino. The study report, issued in 2015, evaluated the long-term reliability of Lake Mendocino to meet water supply and environmental water demands. The study report found that Lake Mendocino's water supply reliability has decreased in recent years as a result of the changed operation of the Potter Valley Project; and

Whereas, the study report also found that future growth projections for the areas that rely on Lake Mendocino for their water supplies are for modest growth through 2045. Even with only modest growth, Lake Mendocino's water supply reliability is expected to continue to further decline, both under scenarios that assume historical climate conditions, and under scenarios that assume potential changes to climate; and

Whereas, the study report discusses a scenario evaluating the effect of no Potter Valley Project diversions (with current demand conditions and historic climate conditions). Under this scenario, Lake Mendocino would go dry for at least some period during more than 60 percent of the years; and

Whereas, further analysis finds that if Lake Mendocino were to go dry with this frequency, there would be severe impacts to downstream water users, ecosystems and groundwater aquifers, including:

- During the fall, the Russian River would operate under the driest conditions for instream flow requirements between 55-66% of the time between September and December;
- Lower lake levels would put at risk the water supplies for communities in Mendocino County and upper Sonoma County (along the Russian River above Healdsburg) and could affect the water supplies for the rest of Sonoma County and Marin County. Hundreds of thousands of people could be impacted;
- Lower lake levels would reduce the amount of Russian River water available to irrigate thousands of acres of vineyards and other crops and

Resolution #

Date:

Page 3

for recreation. Reductions in irrigation supplies could lead to additional groundwater pumping and lower groundwater levels;

- Lower lake levels would reduce the number of years during which cold-water releases could be made for the fall Chinook salmon migration – significantly affecting spawning habitat for this threatened species and overall water quality in the Russian River; and
- Without the Potter Valley Project diversions, releases of stored water from Lake Sonoma would need to increase to provide water supplies for lower Russian River entities and to meet minimum instream flow requirements in the lower Russian River. Additional releases would draw down Lake Sonoma’s reserves, making it less reliable during droughts.

Whereas, the National Marine Fisheries Service (NMFS) issued the Russian River Biological Opinion on September 24, 2008. This opinion was a culmination of more than a decade of consultation between the Sonoma County Water Agency, the Army Corps of Engineers, and NMFS regarding the impact of the Water Agency’s and Corps’ water supply and flood control activities on three fish species listed under the federal Endangered Species Act: Central California Coast steelhead, Central California Coast coho salmon, and California Coastal Chinook salmon; and

Whereas, the Sonoma County Water Agency and its contractors have expended tens of millions of dollars in complying with the Russian River Biological Opinion; and

Whereas, the Sonoma County Water Agency has partnered with the National Oceanic and Atmospheric Administration, the U.S. Army Corps of Engineers, the Bodega Marine Laboratory, the U.S. Geological Survey, the University of California Cooperative Extension, the Gold Ridge Resource Conservation District, the California Department of Fish & Wildlife, the Sonoma County Farm Bureau, the Mendocino County Farm Bureau and Scripps for the Habitat Blueprint Project on the Russian River; and

Whereas, the goals of Habitat Blueprint are: (1) rebuilding endangered coho and threatened steelhead stocks to sustainable levels through habitat protection and restoration; (2) improving frost, rainfall, and river forecasts in the Russian River watershed through improved data collection and modeling; and (3) increasing community resiliency to flooding damage through improved planning and water management strategies; and

Whereas, the partners for Habit Blueprint have collectively invested several millions of dollars in achieving the goals for Habitat Blueprint in the Russian River; and

Whereas, if the diversions from the Potter Valley Project were to cease, the investments and gains made in the Russian River watershed pursuant to the Russian River Biological Opinion and Habitat Blueprint would be placed at risk; and

Whereas, the County of Sonoma and the Sonoma County Water Agency have provided long term support for integrated regional water management planning, which supported the creation of the North Coast Resource Partnership, and most recently, the Russian River Confluence; and

Whereas, NMFS issued a Biological Opinion for the Potter Valley Project License Amendment on November 26, 2002, identifying impacts to the Eel River and Eel River fisheries, including anadromous

Resolution #

Date:

Page 4

fish species listed as threatened under the federal Endangered Species Act, due to the Potter Valley Project. Additionally, the Biological Opinion also identified other impacts on Eel River fisheries including logging, roads, commercial fishing, illegal diversions, droughts and floods; and

Whereas, the Hydropower License for the Potter Valley Project (P-77) is regulated by the Federal Energy Regulatory Commission (FERC); and

Whereas, in 1983, FERC issued a license for the Potter Valley Project which expires on April 14, 2022. The relicensing process began in April 2017, when PG&E filed its Notice of Intent and Preliminary Application Document with FERC, the initial step in the relicensing process; and

Whereas, as part of the relicensing process, FERC will evaluate the environmental impacts of relicensing the Potter Valley Project and will consider reasonable alternatives to PG&E's proposed actions. The environmental analysis will result in the preparation of an Environmental Impact Statement, that will describe and evaluate the probable effects, including an assessment of the site-specific and cumulative effects, if any, of the proposed action and alternatives; and

Whereas, FERC expanded the geographic scope of its analysis of the environmental impacts of Project relicensing to include the potential impacts of relicensing on storage levels in Lake Mendocino and the resources of the Russian River from Lake Mendocino to the Pacific Ocean, including anadromous fish species listed as threatened and endangered species under the federal Endangered Species Act, and the potential impacts of Potter Valley Project relicensing on agricultural and municipal water users that rely on Russian River water supplies; and

Whereas, Congressman Jared Huffman convened an ad hoc committee of interested parties in 2017 to work toward a Two-Basin Solution that addresses issues and concerns in the Eel River and Russian River watersheds; and

Whereas, PG&E announced, on May 10, 2018, its intent to auction the Potter Valley Project; and

Whereas, PG&E on September 6, 2018, began the auction process for soliciting proposals from parties interested in purchasing its Potter Valley Project; and

Whereas, PG&E is using a "request for offers" type of auction process that is intended to meet the needs of both seller and buyer – and considers other factors in addition to price; and

Whereas, depending on how many proposals are received and need to be evaluated, PG&E expects to select proposals and begin formal negotiations with a buyer by mid-2019. The sale and transfer of the Potter Valley Project could be completed within one-and-a-half to two years; and

Whereas, approval by FERC and the California Public Utilities Commission will be needed prior to transfer of ownership; and

Whereas, PG&E is in the second year of the minimum five-year process of obtaining a new operating license from FERC for the Potter Valley Project, and PG&E will continue to own, operate and relicense the Potter Valley Project throughout the auction process.

Now, Therefore, Be It Resolved, that the County of Sonoma and the Sonoma County Water

Resolution #

Date:

Page 5

Agency support the concept of a Two-Basin Solution proposed by Congressman Jared Huffman.

Be It Further Resolved, that the County of Sonoma and the Sonoma County Water Agency support a future for the Potter Valley Project that protects fisheries and water supplies in both the Eel River and Russian River watersheds.

Be It Further Resolved, that the Potter Valley Project is a project of regional importance, and in order to achieve the Two-Basin Solution regional stakeholders will need to work together to implement a regional solution.

Be It Further Resolved, the County of Sonoma and the Sonoma County Water Agency are willing to work with regional partners and stakeholders in furtherance of a Two-Basin Solution.

**Sonoma County
Board of
Supervisors:**

Gorin:

Rabbitt:

Zane:

Hopkins:

Gore:

Ayes:

Noes:

Absent:

Abstain:

So Ordered.

**Board of
Directors of the
Sonoma County
Water Agency:**

Gorin:

Rabbitt:

Zane:

Hopkins:

Gore:

Ayes:

Noes:

Absent:

Abstain:

So Ordered.



County of Sonoma Agenda Item Summary Report

Clerk of the Board
575 Administration Drive
Santa Rosa, CA 95403

Agenda Item Number: 8
(This Section for use by Clerk of the Board Only.)

To: Board of Directors, Sonoma Water

Board Agenda Date: November 13, 2018

Vote Requirement: 4/5

Department or Agency Name(s): Sonoma Water

Staff Name and Phone Number:

Jake Spaulding / 524-8373

Supervisorial District(s):

Title: Advanced Quantitative Precipitation Information System – Consulting Agreements

Recommended Actions:

In support of the Bay Area Advanced Quantitative Precipitation Information System Project, which provides more precise rainfall forecasting to inform flood control, emergency response efforts, and media reporting:

- A) Authorize Sonoma County Water Agency's General Manager to execute an agreement with Jennifer Krebs dba Jennifer Krebs Environmental Planning for project coordination services through December 31, 2021, in the not-to-exceed amount of \$250,000.
- B) Authorize Sonoma County Water Agency's General Manager to execute an agreement with Bay Planning Coalition for stakeholder outreach coordination through December 31, 2021, in the not-to-exceed amount of \$300,000.
- C) Adopt a resolution authorizing adjustments to the Board Adopted Budget for Fiscal Year 2018-2019 in the amount of \$160,418 for the Bay Area Advanced Quantitative Precipitation Information System Project.

Executive Summary:

In August 2016, the Sonoma County Water Agency (Sonoma Water) received \$19.84 million in grant funds to implement the San Francisco Bay Area Advanced Quantitative Precipitation Information System project (Project) over a four year period. Costs incurred by Sonoma Water in implementing the Project and associated agreements will be reimbursed with these grant funds or by local project partners. Current local project partners include but are not limited to Santa Clara Valley Water District, San Francisco Public Utilities Commission, and the Bay Area Flood Protection Agencies Association, as well as Sonoma Water.

The purpose of the Project is to provide more precise rainfall forecasting for atmospheric rivers, which will give flood control managers, including Sonoma Water, emergency responders, transportation officials, and media outlets more precise information on the location, timing, and intensity of expected rainfall.

This item presents for consideration and approval two professional services agreements with technical partners to perform project coordination and stakeholder outreach services in order to successfully implement the Project. The work is funded by the grant award.

Discussion:

HISTORY OF ITEM/BACKGROUND

For more than four years, Sonoma Water and several other agencies in the Bay Area have collaborated with National Oceanic and Atmospheric Administration (NOAA), Colorado State University's Cooperative Institute for Research in the Atmosphere, the United States Geological Survey - Pacific Coast and Marine Science Center, and the Center for Western Weather and Water Extremes at Scripps Institute of Oceanography, to develop a regional project called the "San Francisco Bay Area Advanced Quantitative Precipitation Information System." Its goal is to provide early notification of more precise rainfall location, intensity, and amounts for the improved management of water supply reservoirs, the improved operations of combined sewer and wastewater systems, the improved operations of flood protection facilities, and a myriad of other benefits to transportation and emergency response agencies. According to a cost-benefit analysis performed by NOAA, implementing the Project can be expected to provide benefits exceeding costs by a ratio of at least 4:1. These benefits accrue through a) avoided flood damage costs from early warnings, b) forecast-based operations to maximize reservoir capture for water supply and fisheries flows, c) minimization of water quality impacts from combined wastewater and sewer systems, and d) enhancement of public safety for the various transportation modes (pedestrian, highways, marine, and airports).

On January 13, 2016, the Department of Water Resources announced statewide Proposition 84 (The Safe Drinking Water, Water Quality and Supply, Flood Control, River and Coastal Protection Bond Act of 2006) grant awards that include over \$43 million for water resources-related projects in the San Francisco Bay Area. Nearly half, or \$19.84 million, was awarded to the Project.

The grant funded portion of the Project will take place over four years and will provide improved precipitation and hydrologic information to water agencies and other stakeholders in the San Francisco Bay area to assist the region in mitigating flood hazards, maximize water supply, and enhance ecosystem services. Project costs are funded by the grant from Department of Water Resources through December 2021. The primary emphasis will be to improve short-term (48 hour) monitoring and prediction of high-impact rainfall events. The secondary emphasis will focus on improved medium-range precipitation forecasts (out to 10 days) for water supply.

The first year of the Project was primarily focused on gathering the needs of the local water and flood control entities, deploying temporary radars to begin data collection, and identifying potential sites for the permanent radars. In the second year of the Project, efforts have shifted to installing permanent radars, integrating data into existing federal and local partner operations, and outreach to additional stakeholders that will fund long term operating and maintenance costs after December 2021.

The grant funding will be used to place up to five new radar units throughout the Bay Area, specifically to provide more precise rainfall forecasting for atmospheric rivers. It is estimated that over the last few decades more than 50 percent of major flooding in the Bay Area, and closer to 70 percent in the North Bay, has come from atmospheric rivers that often are not detected with conventional, high-aiming S-band,

or NEXRAD, radar units that were originally designed for thunderstorms in the Midwest. The new radar system also will give flood control managers, emergency responders, transportation officials, and media outlets more precise information on just where, when, and the intensity of expected rainfall.

The radar units will be constructed and installed by Colorado State University's Cooperative Institute for Research in the Atmosphere. Advance modeling will be provided by the NOAA's National Weather Services and the United States Geological Survey – Pacific Coast and Marine Science Center. System integration and overall technical coordination of the Project will be provided by NOAA's Earth Systems Research Laboratory in Boulder, Colorado.

Local Project partners will host radar sites, when site surveys are finalized during the course of the Project. Current local project partners include Santa Clara Valley Water District, San Francisco Public Utilities Commission, and the Bay Area Flood Protection Agencies Association, as well as Sonoma Water.

SELECTION PROCESS

Since 2011, Sonoma Water has been collaborating with NOAA's Earth Systems Research Laboratory and National Weather Service, United States Geological Survey, Colorado State University's Cooperative Institute for Research in the Atmosphere, Morrison and Associates, and the Center for Western Weather and Water Extremes at Scripps Institute of Oceanography to develop the regional Project. In 2013, this Board adopted a resolution supporting continued development of the San Francisco Bay Area Quantitative Precipitation Information System and its inclusion in the San Francisco Bay Area's proposal under Round 3 of Proposition 84 Integrated Regional Water Management Implementation Grant funding application. In January 2016, the Department of Water Resources announced that AQPI Project was awarded \$19.84 million in grant funds for its development. Agreements were executed with the partners involved in the Project development on August 15, 2017.

Under agreement TW16/17-032, Morrison & Associates received \$535,430 to provide meeting coordination, grant management assistance, siting and permitting assistance, and public outreach services during the roughly 4 year period ending is December 31, 2021. The agreement listed both Carl Morrison and Jennifer Krebs as key personal. Morrison & Associates, Inc. was selected for the work as the firm had been utilized by Sonoma Water for numerous tasks (under a separate agreement) involving the Bay Area Integrated Regional Water Management Plan (Plan). Mr. Morrison, through years of work with Plan partners, had the understanding of Bay Area resource issues and credibility with partner agencies to coordinate the local partner agencies and stakeholder interests. Furthermore, Mr. Morrison had a principal role in formulating the AQPI system project, developing the implementation team, and marketing the AQPI Project to the Plan for funding (of which we are receiving approximately \$19.84 million). Mr. Morrison's knowledge and expertise on both general Plan issues and the AQPI Project was critical to successfully implementing the AQPI Project. Furthermore, the Water Agency did not have the capacity to perform the work in house with current staff.

Carl Morrison recently passed away and his family has elected to wind down the firm. Accordingly, Sonoma Water will be terminating agreement TW16/17-032. Mr. Morrison had several characteristics that uniquely qualified him for the scope of work under TW16/17-032. His business partner, Ms. Krebs, was listed as key personal in the agreement and also possesses unique characteristics, experience, and

credibility amongst the Project partners/stakeholders, qualifying her to continue certain tasks. While Mr. Krebs has extensive credibility with the currently engaged stakeholders, the Project requires additional outreach to other stakeholders outside her expertise. Therefore, Sonoma Water has elected to reissue the remaining work under the two agreements discussed in this item.

Agreement for Project Coordination Services Related to the Advanced Quantitative Precipitation Information System Project

This work was originally to be completed by Morrison & Associates under Sonoma Water agreement TW 16/17-032 which was approved by the Board on August 15, 2017.

In light of Mr. Morrison's death and his family's desire to wind down his firm, Jennifer Krebs, who was listed as a key person under agreement TW16/17-032, has formed her own company. Jennifer Krebs dba Jennifer Krebs Environmental Planning will continue the Project Coordination Services tasks, including meeting coordination, grant management assistance, siting and permitting assistance, and some public outreach tasks under the subject agreement.

Agreement for Stakeholder Outreach Coordination Related to the Advanced Quantitative Precipitation Information System

The majority of this work was also originally to be completed by Morrison & Associates under TW 16/17-032. Morrison & Associates completed the initial outreach to local partner agencies involved with water supply, flood control, storm water, and wastewater, but considerable work remains, particularly with entities (public and private) not traditionally involved with the Integrated Regional Water Management process. A sole source waiver was obtained for the Bay Planning Coalition to finish the tasks due to its unique ability to immediately communicate with key Bay Area stakeholders under a tight timeline and budget. This Project is a grant-funded project that requires stakeholder outreach as a part of its grant requirements, and Project will rely on active stakeholder participation to develop and build the most effective extreme weather forecasting tool for our communities. Sonoma Water is a member of the Bay Planning Coalition and is well aware of the Bay Planning Coalition's commitment to success in the Bay Area, along with its relationships with stakeholders. Sonoma Water is confident the Bay Planning Coalition can accomplish the goals and objectives set forth in the scope of work presented under the agreement and in accordance with grant rules and regulations.

SERVICES TO BE PERFORMED

Agreement for Project Coordination Services Related to the Advanced Quantitative Precipitation Information System Project

Under the proposed agreement, Jennifer Krebs will provide meetings coordination, grant management assistance, siting and permitting assistance, public outreach, and monthly progress reports.

The cost of services will not exceed \$250,000; the term end date is December 31, 2021.

Agreement for Stakeholder Outreach Coordination Related to the Advanced Quantitative Precipitation Information System

Under the proposed agreement, Bay Planning Coalition will attend meetings, identify stakeholders, develop stakeholder advisory committee, perform stakeholder outreach and communications, monitor related trends and issues, and provide monthly reports.

The cost of services will not exceed \$300,000. This agreement covers services rendered from August 1, 2018, to December 31, 2021.

RECOMMENDATION

Sonoma Water staff recommends that the Board authorize Sonoma Water’s General Manager to execute the agreement with Jennifer Krebs dba Jennifer Krebs Environmental Planning for project coordination services through December 31, 2021, in the not-to-exceed amount of \$250,000, execute the agreement with Bay Planning Coalition for stakeholder outreach coordination through December 31, 2021, in the not-to-exceed amount of \$300,000, and adopt a resolution authorizing adjustments to the Board Adopted Budget for Fiscal Year 2018-2019 in the amount of \$160,418.

Prior Board Actions:

- 08/15/2017 Authorize General Manager to execute four agreements related to the Bay Area Advanced Quantitative Precipitation Information System and adopt a resolution authorizing adjustments to the adopted FY 2017/2018 budget in the amount of \$9,255,085.
- 03/01/2016 Resolution Authorizing the General Manager or Designee To Execute an Agreement with the California Department of Water Resources for a Proposition 84 IRWMP Implementation Grant on Behalf of the San Francisco Bay Region.
- 11/05/2013 Resolution Supporting the Proposed San Francisco Bay Area Advanced Quantitative Precipitation Information System to be Included in the San Francisco Bay Area’s Proposal under Round 3 of Proposition 84 Integrated Regional Water Management Implementation Grant Funding.

Strategic Plan Alignment Goal 1: Safe, Healthy, and Caring Community

The Project advances the County efforts to be proactive in mitigating and adapting to the causes and impacts of climate change to safeguard the environment, human health, and the economy.

Sonoma Water Strategic Plan Alignment

Flood Protection, Goal 1: Provide efficient and effective flood protection programs.

The Project supports Sonoma Water’s goal of efficient and effective flood protection measures by providing early notification of more precise rainfall location, intensity, and amounts for the improved management of water supply reservoirs, the improved operations of combined sewer and wastewater systems, the improved operations of flood protection facilities.

Fiscal Summary			
Expenditures	FY 18-19 Adopted	FY 19-20 Projected	FY 20-21 Projected
Budgeted Expenses	0	\$160,418	\$160,417
Additional Appropriation Requested	\$160,418		
Total Expenditures	\$160,418	\$160,418	\$160,417
Funding Sources			
General Fund/WA GF			
State/Federal	\$160,418	\$160,418	\$160,417
Fees/Other			
Use of Fund Balance			
Contingencies			
Total Sources	\$160,418	\$160,418	\$160,417
Narrative Explanation of Fiscal Impacts:			
<p>All costs will be reimbursed by grant funds (State). Total anticipated expenditures of \$550,000 for both contracts will be incurred over a period of four fiscal years: \$160,418 in FY 2018/2019; \$160,418 in FY 2019/2020; \$160,417 in FY 2020/2021; and the remaining \$68,747 in FY 2021/2022.</p> <p>FY18/19 had been budgeted under TW16/17-032, but following Mr. Morrison's passing, funds were unencumbered due to uncertainty on how to proceed. Accordingly, additional appropriations are required to process this expense in FY 2018/2019 under the new agreements; therefore, a budgetary resolution has been submitted with this item. FY 2019/2020, FY2020/2021, and FY2021/2022 appropriations will be budgeted in those fiscal years.</p>			
Staffing Impacts			
Position Title (Payroll Classification)	Monthly Salary Range (A – I Step)	Additions (Number)	Deletions (Number)
N/A			
Narrative Explanation of Staffing Impacts (If Required):			
N/A			
Attachments:			
Agreements (two) Resolution (R1)			

Related Items “On File” with the Clerk of the Board:

None

rw S:\Agenda\agrees\10-09-2018 WA Advanced Quantitative
Precipitation Information System_summ.docm

CF/47-0-21 Jennifer Krebs Environmental Planning (Agree for Project Coordination Services
Related to the Advanced Quantitative Precipitation Information System Project) 18/19-002
(ID 7057) and

CF/0-0-21 Bay Planning Coalition (Agree for Stakeholder Outreach Coordination Related to
the Advanced Quantitative Precipitation Information System) 18/19-003 (ID 7056)

Date: November 13, 2018

Item Number: _____
Resolution Number: _____

4/5 Vote Required

Resolution Of The Board Of Directors of the Sonoma County Water Agency Authorizing Adjustments to the Board Adopted Budget for Fiscal Year 2018-2019 for the Sonoma County Water Agency General Fund in the Amount of \$160,418 for the Bay Area Advanced Quantitative Precipitation Information System Project, Offset by \$160,418 in Department of Water Resources Grant Funds

Whereas, the Board of Directors of the Sonoma County Water Agency (Sonoma Water) adopted the Sonoma Water Fiscal Year 2018-2019 budget on June 15, 2018; and

Whereas, Sections 29088 through 29092 of the Government Code, State of California allow for adjustments to the Fiscal Year 2018-2019 Adopted Budget; and

Whereas, Sonoma Water desires to adjust the Fiscal Year 2018-2019 Adopted Budget for the General Fund in the amount of 160,418 for the Bay Area Advanced Quantitative Precipitation Information System Project, Offset by \$160,418 in Department of Water Resources Grant Funds; and

Whereas, a resolution from Sonoma Water’s governing board authorizing such budget adjustment is required.

Now, Therefore, Be It Resolved that the County Auditor-Controller-Treasurer-Tax Collector and the County Administrator are hereby authorized and directed to complete the budgetary and accounting transfers and adjustments to the Sonoma Water Fiscal Year 2018-2019 budget as follows:

Resolution #

Date:

Page 2

Fiscal Year 2018-2019 Expenditures		Amount
X0158-C018	BA AQPI	
14015-33010100	General Fund	
51803	Other Contract Services	160,418.00
Total Expenditures		160,418.00
Fiscal Year 2018-2019 Funding Sources		
X0158-C018	BA AQPI	
14015-33010100	General Fund	
42358	State Other Funding	160,418.00
Total Funding Sources		160,418.00

Supervisors:

Gorin:

Rabbitt:

Zane:

Hopkins:

Gore:

Ayes:

Noes:

Absent:

Abstain:

So Ordered.

Agreement for Project Coordination Services Related to the Advanced Quantitative Precipitation Information System Project

This agreement (“Agreement”) is by and between **Sonoma County Water Agency**, a body corporate and politic of the State of California (“Sonoma Water”) and **Jennifer Krebs dba Jennifer Krebs Environmental Planning**, a sole proprietorship (“Consultant”). The Effective Date of this Agreement is the date the Agreement is last signed by the parties to the Agreement, unless otherwise specified in Paragraph 5.1.

RECITALS

- A. Consultant represents that it is a duly qualified firm, experienced in developing regional water management plans and related services.
- B. The San Francisco Bay Area Advanced Quantitative Precipitation Information (AQPI) System project is financed under Grant Agreement No. 4600011485 (“Grant”) that is funded by the Safe Drinking Water, Water Quality and Supply, Flood Control, River and Coastal Protection Bond Act of 2006, administered by the State of California, Department of Water Resources.
- C. Sonoma Water, acting as grantee and lead administrative agency, will manage administration for the AQPI project including contracting with the Department of Water Resources and project partners.
- D. The National Ocean and Atmospheric Administration (“NOAA”), acting as the Project Director, will direct technical aspects of the project, in conjunction with the Technical Advisory Committee (TAC), including coordinating work with Consultant.
- E. The AQPI TAC is comprised of stakeholders such as NOAA; Colorado State University’s Cooperative Institute for Research in the Atmosphere (“CIRA”); Scripps Institute of Oceanography’s Center for Western Weather and Water Extremes (“CW3E”); the United States Geological Survey (“USGS”); Consultant; and the Local Project Partners that include, but are not limited to, Sonoma Water, San Francisco Public Utilities Commission, Santa Clara Valley Water District, and the Bay Area Flood Protection Agencies Association.
- F. The AQPI Project Management Team will consist of Sonoma Water, Consultant, NOAA, CIRA, CW3E, USGS, and others, as needed.
- G. Sonoma Water needs Consultant’s expertise and experience for work on the AQPI System.

In consideration of the foregoing recitals and the mutual covenants contained herein, the parties hereto agree as follows:

A G R E E M E N T

1. RECITALS

1.1. The above recitals are true and correct.

2. LIST OF EXHIBITS

2.1. The following exhibits are attached hereto and incorporated herein:

- a. Exhibit A: Scope of Work
- b. Exhibit B: Schedule of Costs
- c. Exhibit C: Estimated Budget for Scope of Work
- d. Exhibit D: Grant Award Documents
- e. Exhibit E: Insurance Requirements
- f. Exhibit G: Waiver of Insurance Requirements

3. SCOPE OF SERVICES

3.1. *Consultant's Specified Services:* Consultant shall perform the services described in Exhibit A (Scope of Work), within the times or by the dates provided for in Exhibit A and pursuant to Article 9 (Prosecution of Work). In the event of a conflict between the body of this Agreement and Exhibit A, the provisions in the body of this Agreement shall control.

3.2. *Cooperation with Sonoma Water:* Consultant shall cooperate with Sonoma Water in the performance of all work hereunder. Consultant shall coordinate the work with Sonoma Water's Project Manager. Contact information and mailing addresses:

Sonoma Water	Consultant
Project Manager: Jake Spaulding 404 Aviation Boulevard Santa Rosa, CA 95403-9019 Phone: 707-524-8373 Email: Jake.Spaulding@scwa.ca.gov	Contact: Jennifer Krebs 878 Spruce Street Berkeley, CA 94707 Phone: 510-393-7878 Email: jennifer.krebs@gmail.com
Remit invoices to:	Remit payments to:
Susan Bookmyer Same address as above or Email: susan.bookmyer@scwa.ca.gov	Same as above

3.3. *Performance Standard and Standard of Care:* Consultant hereby agrees that all its work will be performed and that its operations shall be conducted in accordance with the standards of a reasonable professional having specialized knowledge and expertise in the services provided under this Agreement and in accordance with all applicable federal, state and local laws, it being understood

that acceptance of Consultant's work by Sonoma Water shall not operate as a waiver or release. Sonoma Water has relied upon the professional ability and training of Consultant as a material inducement to enter into this Agreement. If Sonoma Water determines that any of Consultant's work is not in accordance with such level of competency and standard of care, Sonoma Water, in its sole discretion, shall have the right to do any or all of the following: (a) require Consultant to meet with Sonoma Water to review the quality of the work and resolve matters of concern; (b) require Consultant to repeat the work at no additional charge until it is satisfactory; (c) terminate this Agreement pursuant to the provisions of Article 6 (Termination); or (d) pursue any and all other remedies at law or in equity.

3.4. *Assigned Personnel:*

- a. Consultant shall assign only competent personnel to perform work hereunder. In the event that at any time Sonoma Water, in its sole discretion, desires the removal of any person or persons assigned by Consultant to perform work hereunder, Consultant shall remove such person or persons immediately upon receiving written notice from Sonoma Water.
- b. Any and all persons identified in this Agreement or any exhibit hereto as the project manager, project team, or other professional performing work hereunder are deemed by Sonoma Water to be key personnel whose services were a material inducement to Sonoma Water to enter into this Agreement, and without whose services Sonoma Water would not have entered into this Agreement. Consultant shall not remove, replace, substitute, or otherwise change any key personnel without the prior written consent of Sonoma Water.
- c. In the event that any of Consultant's personnel assigned to perform services under this Agreement become unavailable due to resignation, sickness, or other factors outside of Consultant's control, Consultant shall be responsible for timely provision of adequately qualified replacements.

4. PAYMENT

4.1. *Total Costs:* Total costs under this Agreement shall not exceed \$250,000.

- a. Total costs for Tasks 1-5 shall not exceed \$230,000.
- b. Total costs for Optional Task 6, if requested in writing by Sonoma Water, shall not exceed \$20,000.
- c. No more than \$225,000 will be paid until the draft report is submitted.

4.2. *Method of Payment:* Consultant shall be paid in accordance with the following terms:

- a. Consultant shall be paid in accordance with Exhibit B (Schedule of Costs). Billed hourly rates shall include all costs for overhead and any other charges, other than expenses specifically identified in Exhibit B. Expenses not expressly authorized by the Agreement shall not be reimbursed.

- b. Retention:
 - i. State of California is withholding 10% of each invoice as retention, amounting to 10% of the total Agreement.
 - ii. Payments made by Sonoma Water to Consultant are subject to this 10% retention.
 - iii. Retention amounts will be released by Sonoma Water to Consultant upon acceptance of Grant Completion Report by State of California.
- 4.3. *Invoices:* Consultant shall submit its bills in arrears on a monthly basis, based on work completed for the period, in a form approved by Sonoma Water. The bills shall show or include:
 - a. Consultant name
 - b. Name of Agreement
 - c. Sonoma Water's Project-Activity Codes:
 - i. Tasks 1, 2, 3, 5, and 6: X0158C018
 - ii. Task 4: X0158D038
 - iii. Travel Expenses: X0158A009
 - d. Task performed with an itemized description of services rendered by date
 - e. Summary of work performed by subconsultants, as described in Paragraph 14.4
 - f. Time in quarter hours devoted to the task
 - g. Hourly rate or rates of the persons performing the task
 - h. List of reimbursable materials and expenses
 - i. Copies of receipts for reimbursable materials and expenses
- 4.4. *Monthly Reports with Invoices:* Payment of invoices is subject to receipt of the monthly reports required under Task 6 of Exhibit A.
- 4.5. *Cost Tracking:* Consultant has provided an estimated breakdown of costs, included in Exhibit C (Estimated Budget for Scope of Work). Exhibit C will only be used as a tool to monitor progress of work and budget. Actual payment will be made as specified in Paragraph 4.2 above.
- 4.6. *Timing of Payments:* Unless otherwise noted in this Agreement, payments shall be made within the normal course of Sonoma Water business after presentation of an invoice in a form approved by Sonoma Water for services performed. Payments shall be made only upon the satisfactory completion of the services as determined by Sonoma Water.
- 4.7. *Taxes Withheld by Sonoma Water:*
 - a. Pursuant to California Revenue and Taxation Code (R&TC) section 18662, Sonoma Water shall withhold seven percent of the income paid to Consultant for services performed within the State of California under this

Agreement, for payment and reporting to the California Franchise Tax Board, if Consultant does not qualify as: (1) a corporation with its principal place of business in California, (2) an LLC or Partnership with a permanent place of business in California, (3) a corporation/LLC or Partnership qualified to do business in California by the Secretary of State, or (4) an individual with a permanent residence in the State of California.

- b. If Consultant does not qualify, as described in Paragraph 4.7.a, Sonoma Water requires that a completed and signed Form 587 be provided by Consultant in order for payments to be made. If Consultant is qualified, as described in Paragraph 4.7.a, then Sonoma Water requires a completed Form 590. Forms 587 and 590 remain valid for the duration of the Agreement provided there is no material change in facts. By signing either form, Consultant agrees to promptly notify Sonoma Water of any changes in the facts. Forms should be sent to Sonoma Water pursuant to Article 15 (Method and Place of Giving Notice, Submitting Bills, and Making Payments) of this Agreement. To reduce the amount withheld, Consultant has the option to provide Sonoma Water with either a full or partial waiver from the State of California.

- 4.8. *State or Grant Funding:* Consultant is informed and aware that this Agreement is funded by a grant from Department of Water Resources (award number 2015 Proposition 84 Integrated Regional Water Management Implementation Grant Agreement No. 4600011485), which grant is conditioned upon various terms that apply to Consultant. Consultant has reviewed the grant award documents attached hereto as Exhibit D and hereby agrees to comply with them to the extent they apply to a subrecipient. In the event of a conflict between the body of this Agreement and Exhibit D, the provisions in Exhibit D shall control.

5. TERM OF AGREEMENT AND COMMENCEMENT OF WORK

- 5.1. *Term of Agreement:* The term of this Agreement shall be from October 1, 2018 (“Effective Date”) to December 31, 2021, unless terminated earlier in accordance with the provisions of Article 6 (Termination).
- 5.2. *Commencement of Work:* Consultant is authorized to proceed immediately with the performance of this Agreement upon the Effective Date of this Agreement.

6. TERMINATION

- 6.1. *Authority to Terminate:* Sonoma Water’s right to terminate may be exercised by Sonoma Water's General Manager.
- 6.2. *Termination Without Cause:* Notwithstanding any other provision of this Agreement, at any time and without cause, Sonoma Water shall have the right, in its sole discretion, to terminate this Agreement by giving 5 days written notice to Consultant.

- 6.3. *Termination for Cause:* Notwithstanding any other provision of this Agreement, should Consultant fail to perform any of its obligations hereunder, within the time and in the manner herein provided, or otherwise violate any of the terms of this Agreement, Sonoma Water may immediately terminate this Agreement by giving Consultant written notice of such termination, stating the reason for termination.
- 6.4. *Delivery of Work Product and Final Payment Upon Termination:* In the event of termination, Consultant, within 14 days following the date of termination, shall deliver to Sonoma Water all reports, original drawings, graphics, plans, studies, and other data or documents, in whatever form or format, assembled or prepared by Consultant or Consultant's subcontractors, consultants, and other agents in connection with this Agreement subject to Paragraph 12.10 and shall submit to Sonoma Water an invoice showing the services performed, hours worked, and copies of receipts for reimbursable expenses up to the date of termination.
- 6.5. *Payment Upon Termination:* Upon termination of this Agreement by Sonoma Water, Consultant shall be entitled to receive as full payment for all services satisfactorily rendered and reimbursable expenses properly incurred hereunder, an amount which bears the same ratio to the total payment specified in the Agreement as the services satisfactorily rendered hereunder by Consultant bear to the total services otherwise required to be performed for such total payment; provided, however, that if services are to be paid on a per-hour or per-day basis, then Consultant shall be entitled to receive as full payment an amount equal to the number of hours or days actually worked prior to termination multiplied by the applicable hourly or daily rate; and further provided, however, that if Sonoma Water terminates the Agreement for cause pursuant to Paragraph 6.3, Sonoma Water shall deduct from such amounts the amount of damage, if any, sustained by Sonoma Water by virtue of the breach of the Agreement by Consultant.
- 6.6. *Change in Funding:* Consultant understands and agrees that Sonoma Water shall have the right to terminate this Agreement immediately upon written notice to Consultant in the event that (1) any state or federal agency or other funder reduces, withholds or terminates funding which Sonoma Water anticipated using to pay Consultant for services provided under this Agreement or (2) Sonoma Water has exhausted all funds legally available for payments due under this Agreement.

7. **INDEMNIFICATION**

- 7.1. Consultant agrees to accept all responsibility for loss or damage to any person or entity, including Sonoma County Water Agency and State of California, and to indemnify, hold harmless, and release Sonoma County Water Agency and State of California, their officers, agents, and employees, from and against any actions,

claims, damages, liabilities, disabilities, or expenses, that may be asserted by any person or entity, including Consultant, that arise out of, pertain to, or relate to Consultant's or its agents', employees', contractors', subcontractors', or invitees' performance or obligations under this Agreement. Consultant agrees to provide a complete defense for any claim or action brought against Sonoma County Water Agency or State of California based upon a claim relating to Consultant's or its agents', employees', contractors', subcontractors', or invitees' performance or obligations under this Agreement. Consultant's obligations under this Article 7 apply whether or not there is concurrent or contributory negligence on the part of Sonoma County Water Agency or State of California, but, to the extent required by law, excluding liability due to conduct of Sonoma County Water Agency or State of California. Sonoma County Water Agency and State of California shall have the right to select their legal counsel at Consultant's expense, subject to Consultant's approval, which shall not be unreasonably withheld. This indemnification obligation is not limited in any way by any limitation on the amount or type of damages or compensation payable to or for Consultant or its agents under workers' compensation acts, disability benefits acts, or other employee benefit acts.

8. INSURANCE

8.1. With respect to performance of work under this Agreement, Consultant shall maintain and shall require all of its subcontractors, consultants, and other agents to maintain, insurance as described in Exhibit E (Insurance Requirements). Consultant affirms that it is aware of the provisions of section 3700 of the California Labor Code, which requires every employer to be insured against liability for workers' compensation or to undertake self-insurance in accordance with the provisions of that code, and Consultant affirms that it will comply with such provisions before commencing the performance of the work under this Agreement and will make its contractors and subcontractors aware of this provision.

9. PROSECUTION OF WORK

9.1. Performance of the services hereunder shall be completed within the time required herein, provided, however, that if the performance is delayed by earthquake, flood, high water, or other Act of God or by strike, lockout, or similar labor disturbances, the time for Consultant's performance of this Agreement shall be extended by a number of days equal to the number of days Consultant has been delayed.

10. EXTRA OR CHANGED WORK

10.1. Extra or changed work or other changes to the Agreement may be authorized only by written amendment to this Agreement, signed by both parties. Changes to lengthen time schedules or make minor modifications to the scope of work, which do not increase the amount paid under the Agreement, may be executed

by Sonoma Water's General Manager in a form approved by County Counsel. The parties expressly recognize that Sonoma Water personnel are without authorization to order all other extra or changed work or waive Agreement requirements. Failure of Consultant to secure such written authorization for extra or changed work shall constitute a waiver of any and all right to adjustment in the Agreement price or Agreement time due to such unauthorized work and thereafter Consultant shall be entitled to no compensation whatsoever for the performance of such work. Consultant further expressly waives any and all right or remedy by way of restitution and quantum meruit for any and all extra work performed without such express and prior written authorization of Sonoma Water.

11. CONTENT ONLINE ACCESSIBILITY

- 11.1. *Accessibility:* Sonoma Water policy requires that all documents that may be published to the Web meet accessibility standards to the greatest extent possible, and utilizing available existing technologies.
- 11.2. *Standards:* All consultants responsible for preparing content intended for use or publication on a Sonoma Water managed or Sonoma Water funded web site must comply with applicable federal accessibility standards established by 36 C.F.R. section 1194, pursuant to section 508 of the Rehabilitation Act of 1973, as amended (29 U.S.C. section 794(d)), and Sonoma Water's Web Site Accessibility Policy located at <http://sonomacounty.ca.gov/Services/Web-Standards-and-Guidelines/>.
- 11.3. *Certification:* With each final deliverable intended for public distribution (report, presentations posted to the Internet, public outreach materials), Consultant shall include a descriptive summary describing how all deliverable documents were assessed for accessibility (e.g., Microsoft Word accessibility check; Adobe Acrobat accessibility check, or other commonly accepted compliance check).
- 11.4. *Alternate Format:* When it is strictly impossible due to the unavailability of technologies required to produce an accessible document, Consultant shall identify the anticipated accessibility deficiency prior to commencement of any work to produce such deliverables. Consultant agrees to cooperate with Sonoma Water staff in the development of alternate document formats to maximize the facilitative features of the impacted document(s); e.g., embedding the document with alt-tags that describe complex data/tables.
- 11.5. *Noncompliant Materials; Obligation to Cure:* Remediation of any materials that do not comply with Sonoma Water's Web Site Accessibility Policy shall be the responsibility of Consultant. If Sonoma Water, in its sole and absolute discretion, determines that any deliverable intended for use or publication on any Sonoma Water managed or Sonoma Water funded Web site does not comply with Sonoma Water Accessibility Standards, Sonoma Water will promptly inform Consultant in writing. Upon such notice, Consultant shall, without charge to

Sonoma Water, repair or replace the non-compliant materials within such period of time as specified by Sonoma Water in writing. If the required repair or replacement is not completed within the time specified, Sonoma Water shall have the right to do any or all of the following, without prejudice to Sonoma Water's right to pursue any and all other remedies at law or in equity:

- a. Cancel any delivery or task order
- b. Terminate this Agreement pursuant to the provisions of Article 6 (Termination); and/or
- c. In the case of custom Electronic and Information Technology (EIT) developed by Consultant for Sonoma Water, Sonoma Water may have any necessary changes or repairs performed by itself or by another contractor. In such event, Consultant shall be liable for all expenses incurred by Sonoma Water in connection with such changes or repairs.

- 11.6. *Sonoma Water's Rights Reserved:* Notwithstanding the foregoing, Sonoma Water may accept deliverables that are not strictly compliant with Sonoma Water Accessibility Standards if Sonoma Water, in its sole and absolute discretion, determines that acceptance of such products or services is in Sonoma Water's best interest.

12. REPRESENTATIONS OF CONSULTANT

- 12.1. *Status of Consultant:* The parties intend that Consultant, in performing the services specified herein, shall act as an independent contractor and shall control the work and the manner in which it is performed. Consultant is not to be considered an agent or employee of Sonoma Water and is not entitled to participate in any pension plan, worker's compensation plan, insurance, bonus, or similar benefits Sonoma Water provides its employees. In the event Sonoma Water exercises its right to terminate this Agreement pursuant to Article 6 (Termination), Consultant expressly agrees that it shall have no recourse or right of appeal under rules, regulations, ordinances, or laws applicable to employees.
- 12.2. *No Suspension or Debarment:* Consultant warrants that it is not presently debarred, suspended, proposed for debarment, declared ineligible, or voluntarily excluded from participation in covered transactions by any federal department or agency. Consultant also warrants that it is not suspended or debarred from receiving federal funds as listed in the List of Parties Excluded from Federal Procurement or Non-procurement Programs issued by the General Services Administration.
- 12.3. *Taxes:* Consultant agrees to file federal and state tax returns and pay all applicable taxes on amounts paid pursuant to this Agreement and shall be solely liable and responsible to pay such taxes and other obligations, including, but not limited to, state and federal income and FICA taxes. Consultant agrees to indemnify and hold Sonoma Water harmless from any liability which it may incur to the United States or to the State of California or to any other public entity as a

consequence of Consultant's failure to pay, when due, all such taxes and obligations. In case Sonoma Water is audited for compliance regarding any withholding or other applicable taxes, Consultant agrees to furnish Sonoma Water with proof of payment of taxes on these earnings.

- 12.4. *Records Maintenance:* Consultant shall keep and maintain full and complete documentation and accounting records, in accordance with generally accepted accounting principles and practices, including, but not limited to, books, records, and other documents concerning all services performed that are compensable under this Agreement and shall make such documents and records available to Sonoma Water and the State of California for inspection at any reasonable time. Consultant shall maintain such records for a period of four (4) years following completion of work hereunder or final billing, whichever comes later.
- 12.5. *Conflict of Interest:* Consultant covenants that it presently has no interest and that it will not acquire any interest, direct or indirect, that represents a financial conflict of interest under state law or that would otherwise conflict in any manner or degree with the performance of its services hereunder. Consultant further covenants that in the performance of this Agreement no person having any such interests shall be employed. In addition, if required by law or requested to do so by Sonoma Water, Consultant shall submit a completed Fair Political Practices Commission Statement of Economic Interests (Form 700) with Sonoma Water within 30 calendar days after the Effective Date of this Agreement and each year thereafter during the term of this Agreement, or as required by state law.
- 12.6. *Statutory Compliance/Living Wage Ordinance:* Consultant agrees to comply, and to ensure compliance by its subconsultants or subcontractors, with all applicable federal, state and local laws, regulations, statutes and policies, including but not limited to the County of Sonoma Living Wage Ordinance, applicable to the services provided under this Agreement as they exist now and as they are changed, amended or modified during the term of this Agreement. Without limiting the generality of the foregoing, Consultant expressly acknowledges and agrees that this Agreement is subject to the provisions of Article XXVI of Chapter 2 of the Sonoma County Code, requiring payment of a living wage to covered employees. Noncompliance during the term of the Agreement will be considered a material breach and may result in termination of the Agreement or pursuit of other legal or administrative remedies.
- 12.7. *Nondiscrimination:* During the performance of this Agreement, Consultant and its contractors or subcontractors shall not unlawfully discriminate, harass, or allow harassment against any employee or applicant for employment because of sex (gender), sexual orientation, race, color, ancestry, religion, creed, national origin (including language use restriction), pregnancy, physical disability (including HIV and AIDS), mental disability, medical condition (cancer/genetic characteristics), age (over 40), marital status, and denial of medial and family

care leave or pregnancy disability leave. Consultant and its contractors or subcontractors shall ensure that the evaluation and treatment of their employees and applicants for employment are free from such discrimination and harassment. Consultant and its contractors or subcontractors shall comply with the provisions of the Fair Employment and Housing Act (California Government Code §12990 (a-f) et seq.) and the applicable regulations promulgated there under (California Code of Regulations, Title 2, §7285 et seq.). The applicable regulations of the Fair Employment and Housing Commission implementing California Government Code section 12990 (a-f), set forth in Chapter 5 of Division 4 of Title 2 of the California Code of Regulations, are incorporated into this Agreement by reference and made a part hereof as if set forth in full. Consultant and its contractors or subcontractors shall give written notice of their obligations under this clause to labor organizations with which they have a collective bargaining or other agreement.

- 12.8. *Drug-Free Workplace Certification (Certification of Compliance)*: By signing this Agreement, Consultant, its contractors or subcontractors hereby certify, under penalty of perjury under the laws of State of California, compliance with the requirements of the Drug-Free Workplace Act of 1990 (Government Code §8350 et seq.) and have or will provide a drug-free workplace by taking the following actions:
- a. Publish a statement notifying employees, contractors, and subcontractors that unlawful manufacture, distribution, dispensation, possession, or use of a controlled substance is prohibited and specifying actions to be taken against employees, contractors, or subcontractors for violations, as required by Government Code section 8355(a)(1).
 - b. Establish a Drug-Free Awareness Program, as required by Government Code section 8355(a)(2) to inform employees, contractors, or subcontractors about all of the following:
 - i. The dangers of drug abuse in the workplace,
 - ii. Consultant's policy of maintaining a drug-free workplace,
 - iii. Any available counseling, rehabilitation, and employee assistance programs, and
 - iv. Penalties that may be imposed upon employees, contractors, and subcontractors for drug abuse violations.
 - c. Provide, as required by Government Code section 8355(a)(3), that every employee, contractor, and/or subcontractor who works under this Agreement:
 - i. Will receive a copy of Consultant's drug-free policy statement, and
 - ii. Will agree to abide by terms of Consultant's condition of employment, contract or subcontract.
- 12.9. *Assignment of Rights*: Consultant assigns to Sonoma Water all rights throughout the world in perpetuity in the nature of copyright, trademark, patent, right to

ideas, in and to all versions of the plans and specifications, if any, now or later prepared by Consultant in connection with this Agreement. Consultant agrees to take such actions as are necessary to protect the rights assigned to Sonoma Water in this Agreement, and to refrain from taking any action which would impair those rights. Consultant's responsibilities under this provision include, but are not limited to, placing proper notice of copyright on all versions of the plans and specifications as Sonoma Water may direct, and refraining from disclosing any versions of the plans and specifications to any third party without first obtaining written permission of Sonoma Water. Consultant shall not use or permit another to use the plans and specifications in connection with this or any other project without first obtaining written permission of Sonoma Water.

12.10. *Ownership and Disclosure of Work Product:* All reports, original drawings, graphics, plans, studies, and other data or documents ("documents"), in whatever form or format, assembled or prepared by Consultant or Consultant's subcontractors, consultants, and other agents in connection with this Agreement shall be the property of Sonoma Water. Sonoma Water shall be entitled to immediate possession of such documents upon completion of the work pursuant to this Agreement. Upon expiration or termination of this Agreement, Consultant shall promptly deliver to Sonoma Water all such documents, which have not already been provided to Sonoma Water in such form or format as Sonoma Water deems appropriate. Such documents shall be and will remain the property of Sonoma Water without restriction or limitation. Consultant may retain copies of the above described documents but agrees not to disclose or discuss any information gathered, discovered, or generated in any way through this Agreement without the express written permission of Sonoma Water.

13. DEMAND FOR ASSURANCE

13.1. Each party to this Agreement undertakes the obligation that the other's expectation of receiving due performance will not be impaired. When reasonable grounds for insecurity arise with respect to the performance of either party, the other may in writing demand adequate assurance of due performance and until such assurance is received may, if commercially reasonable, suspend any performance for which the agreed return has not been received. "Commercially reasonable" includes not only the conduct of a party with respect to performance under this Agreement, but also conduct with respect to other agreements with parties to this Agreement or others. After receipt of a justified demand, failure to provide within a reasonable time, but not exceeding thirty (30) days, such assurance of due performance as is adequate under the circumstances of the particular case is a repudiation of this Agreement. Acceptance of any improper delivery, service, or payment does not prejudice the aggrieved party's right to demand adequate assurance of future performance. Nothing in this Article 13 limits Sonoma Water's right to terminate this Agreement pursuant to Article 6 (Termination).

14. ASSIGNMENT AND DELEGATION

- 14.1. *Consent:* Neither party hereto shall assign, delegate, sublet, or transfer any interest in or duty under this Agreement without the prior written consent of the other, and no such transfer shall be of any force or effect whatsoever unless and until the other party shall have so consented.
- 14.2. *Subcontracts:* Notwithstanding the foregoing, Consultant may enter into subcontracts with the subconsultants specifically identified herein. If no subconsultants are listed, then no subconsultants will be utilized in the performance of the work specified in this Agreement.
- 14.3. *Change of Subcontractors or Subconsultants:* If, after execution of the Agreement, parties agree that subconsultants not listed in Paragraph 14.2 will be utilized, Consultant may enter into subcontracts with subconsultants to perform other specific duties pursuant to the provisions of this Paragraph 14.3. The following provisions apply to any subcontract entered into by Consultant other than those listed in Paragraph 14.2:
- a. Prior to entering into any contract with subconsultant, Consultant shall obtain Sonoma Water approval of subconsultant.
 - b. All agreements with subconsultants shall (a) contain indemnity requirements in favor of Sonoma Water in substantially the same form as that contained in Article 7 (Indemnification), (b) contain language that the subconsultant may be terminated with or without cause upon reasonable written notice, and (c) prohibit the assignment or delegation of work under the agreement to any third party.
- 14.4. *Summary of Subconsultants' Work:* Consultant shall provide Sonoma Water with a summary of work performed by subconsultants with each invoice submitted under Paragraph 4.3. Such summary shall identify the individuals performing work on behalf of subconsultants and the total amount paid to subconsultant, broken down by the tasks listed in the Scope of Work.

15. METHOD AND PLACE OF GIVING NOTICE, SUBMITTING BILLS, AND MAKING PAYMENTS

- 15.1. *Method of Delivery:* All notices, bills, and payments shall be made in writing and shall be given by personal delivery, U.S. Mail, courier service, or electronic means. Notices, bills, and payments shall be addressed as specified in Paragraph 3.2.
- 15.2. *Receipt:* When a notice, bill, or payment is given by a generally recognized overnight courier service, the notice, bill, or payment shall be deemed received on the next business day. When a copy of a notice, bill, or payment is sent by electronic means, the notice, bill, or payment shall be deemed received upon transmission as long as (1) the original copy of the notice, bill, or payment is deposited in the U.S. mail and postmarked on the date of the electronic

transmission (for a payment, on or before the due date), (2) the sender has a written confirmation of the electronic transmission, and (3) the electronic transmission is transmitted before 5 p.m. (recipient's time). In all other instances, notices, bills, and payments shall be effective upon receipt by the recipient. Changes may be made in the names and addresses of the person to whom notices are to be given by giving notice pursuant to this Article 15.

16. MISCELLANEOUS PROVISIONS

- 16.1. *No Bottled Water:* In accordance with Sonoma Water Board of Directors Resolution No. 09-0920, dated September 29, 2009, no Sonoma Water funding shall be used to purchase single-serving, disposable water bottles for use in Sonoma Water facilities or at Sonoma Water-sponsored events. This restriction shall not apply when potable water is not available.
- 16.2. *No Waiver of Breach:* The waiver by Sonoma Water of any breach of any term or promise contained in this Agreement shall not be deemed to be a waiver of such term or promise or any subsequent breach of the same or any other term or promise contained in this Agreement.
- 16.3. *Construction:* To the fullest extent allowed by law, the provisions of this Agreement shall be construed and given effect in a manner that avoids any violation of statute, ordinance, regulation, or law. The parties covenant and agree that in the event that any provision of this Agreement is held by a court of competent jurisdiction to be invalid, void, or unenforceable, the remainder of the provisions hereof shall remain in full force and effect and shall in no way be affected, impaired, or invalidated thereby. Consultant and Sonoma Water acknowledge that they have each contributed to the making of this Agreement and that, in the event of a dispute over the interpretation of this Agreement, the language of the Agreement will not be construed against one party in favor of the other. Consultant and Sonoma Water acknowledge that they have each had an adequate opportunity to consult with counsel in the negotiation and preparation of this Agreement.
- 16.4. *Consent:* Wherever in this Agreement the consent or approval of one party is required to an act of the other party, such consent or approval shall not be unreasonably withheld or delayed.
- 16.5. *No Third-Party Beneficiaries:* Except as provided in Article 7 (Indemnification), nothing contained in this Agreement shall be construed to create and the parties do not intend to create any rights in third parties.
- 16.6. *Applicable Law and Forum:* This Agreement shall be construed and interpreted according to the substantive law of California, regardless of the law of conflicts to the contrary in any jurisdiction. Any action to enforce the terms of this Agreement or for the breach thereof shall be brought and tried in Santa Rosa or in the forum nearest to the City of Santa Rosa, in the County of Sonoma.

- 16.7. *Captions:* The captions in this Agreement are solely for convenience of reference. They are not a part of this Agreement and shall have no effect on its construction or interpretation.
- 16.8. *Merger:* This writing is intended both as the final expression of the Agreement between the parties hereto with respect to the included terms and as a complete and exclusive statement of the terms of the Agreement, pursuant to Code of Civil Procedure section 1856. Each Party acknowledges that, in entering into this Agreement, it has not relied on any representation or undertaking, whether oral or in writing, other than those which are expressly set forth in this Agreement. No modification of this Agreement shall be effective unless and until such modification is evidenced by a writing signed by both parties.
- 16.9. *Survival of Terms:* All express representations, waivers, indemnifications, and limitations of liability included in this Agreement will survive its completion or termination for any reason.
- 16.10. *Time of Essence:* Time is and shall be of the essence of this Agreement and every provision hereof.

/

/

/

/

/

/

/

/

/

/

/

/

/

/

/

/

/

/

/

/

/

/

IN WITNESS WHEREOF, the parties hereto have executed this Agreement as of the date last signed by the parties to the Agreement.

Reviewed as to funds:

TW 18/19-002

By: _____
Sonoma Water Division Manager -
Administrative Services

Approved as to form:

By: _____
Adam Brand, Deputy County Counsel

Insurance Documentation is on file with
Sonoma Water

Date/TW Initials: _____

Sonoma County Water Agency

**Jennifer Krebs dba Jennifer Krebs
Environmental Planning, a sole proprietorship**

By: _____
Grant Davis
General Manager
Authorized per Sonoma Water's Board
of Directors Action on _____

By: _____

(Please print Owner's name here)

Title: _____

Date: _____

Date: _____

Exhibit A

Scope of Work

1. TASKS

1.1. Task 1: Meeting Coordination

- a. In consultation with Sonoma Water and Bay Planning Coalition, schedule and convene meetings with Project Partners, including meetings of the Project Management Team, TAC, and Communication and Outreach Team, as well as, schedule and convene other meetings, as needed.
- b. Work with Sonoma Water and Bay Planning Coalition to develop systems to assist Project Partners in communications, such as (Dropbox and/or Google Drive protocols), GoToMeeting routines, and in-person meetings at reasonable intervals.
- c. Assist NOAA, CIRA, and other out-of-region agencies in meeting with Sonoma Water and other regional agencies regarding:
 - i. Radar siting
 - ii. AQPI development
 - iii. AQPI user interface
- d. Prepare meeting agendas and summaries or minutes.

Deliverable	Due Date
Meeting Agenda	Two calendar days prior to each meeting
Meeting Minutes or Summary	Within 7 calendar days of each meeting

1.2. Task 2: Grant Management Assistance

- a. Develop a system for DWR report submittals including, but not limited to:
 - i. Developing reporting and invoicing templates
 - ii. Setting up on-line folders for submittals
 - iii. Maintaining these systems over the life of the AQPI Project
- b. Review quarterly reports for entire AQPI Project and review invoices from Sonoma Water subcontractors.

Deliverable	Due Date
None.	N/A

1.3. Task 3: Siting and Permitting Assistance

- a. Set up meetings between NOAA, CIRA, USGS, and Bay Area agencies who may host radar units and other surface monitoring hardware to ensure expeditious permitting.
- b. Research or assist with permitting for hardware, as requested by Sonoma Water.

- c. Provide a summary of each meeting or trip, and correspondence, regarding siting, including:
 - i. Agenda
 - ii. Attendees
 - iii. Topics
 - iv. Issues
 - v. Results
 - vi. Action items
 - vii. Next steps

Deliverable	Due Date
Summary	Within 7 calendar days of each meeting/trip/correspondence

1.4. Task 4: Public Outreach

- a. In coordination with Sonoma Water and Bay Planning Coalition develop and maintain list(s) of Project Partners and stakeholders.
- b. In coordination with Sonoma Water and Bay Planning Coalition develop an Outreach Plan for AQPI Project, and update as needed to ensure the Outreach Plan is meeting AQPI Project needs. Include the following in the outreach plan:
 - i. Purpose of plan
 - ii. List of AQPI stakeholders
 - iii. Outreach opportunities, such as events, meetings to attend and speak on AQPI
 - iv. Material development
 - a) Outline of materials to be used for creating AQPI
 - b) 5-year scope
 - v. Stakeholder outreach schedule including meetings with stakeholders, location(s), and number of meetings
 - vi. Ways to build participation, commitment, and investment in AQPI Project
- c. Develop web content for Sonoma Water’s AQPI webpage. Consult with Sonoma Water on development of webpage. Regularly check in with Sonoma Water regarding new information to be posted by Sonoma Water.
- d. Develop and produce electronic and print brochures as requested by Sonoma Water.
- e. Convene Communications and Outreach Team meetings at intervals determined appropriate by Sonoma Water and the Project Management Team.
- f. In coordination with Sonoma Water and Bay Planning Coalition Convene Stakeholder Advisory Committee meetings at intervals determined appropriate by Sonoma Water and the Project Management Team.

- g. Provide a list of conferences and workshops to attend and present AQPI Project; Sonoma Water to pre-approve list.
- h. Provide a conferences and workshops to present information about the AQPI Project and attend those approved by Sonoma Water.
- i. Review and Approval of Deliverables for Task 4.
 - i. First Draft: Prepare the deliverables in draft form and submit to Sonoma Water for review and approval in accordance with the date listed below. Sonoma Water will return one copy of the draft deliverables to Consultant with comments or approval in writing.
 - ii. Subsequent Draft(s): If Sonoma Water requests revisions, revise the draft deliverables and resubmit one copy for Sonoma Water approval.
 - iii. Final: Following Sonoma Water approval and prior to Sonoma Water's acceptance of work under this Agreement, submit the final approved deliverables to Sonoma Water in accordance with the date listed below.

Deliverable	Due Date
List(s) of Project Partners and stakeholders	To be determined
Draft Outreach Plan	To be determined
Final Outreach Plan	To be determined
Draft web content	To be determined
Final web content	To be determined
Draft brochure(s)	To be determined
Final brochure(s)	To be determined
List of Conferences and Workshops	To be determined.
Summary	Within 7 calendar days of each meeting/ trip/ correspondence

1.5. Task 5: Monthly Progress Reports

- a. Prepare monthly progress reports. Submit one copy to Sonoma Water in accordance with the date listed for this deliverable.
- b. Include the following in each monthly progress:
 - i. A detailed list of work performed
 - ii. Dates and subject of meetings conducted, meeting attendees, and summary of meeting results
 - iii. A detailed description of the progress of each task
 - iv. Detailed summary of costs incurred for the reporting month
 - v. Detailed summary of costs incurred to date
 - vi. Remaining balance of Agreement
 - vii. Outline of work anticipated to be performed in the upcoming 3 months
 - viii. Other information as appropriate or as requested by Sonoma Water

Deliverable	Due Date
Monthly Progress Report	Monthly with invoices

- 1.6. Optional Task 6: Additional Services
- a. Do not proceed with this task unless requested in writing by Sonoma Water.
 - b. Perform additional services as requested by Sonoma Water to support the AQPI effort. The additional services will be agreed to by Consultant and Sonoma Water and described in writing by Sonoma Water.

Deliverable	Due Date
To be determined	To be determined

2. DELIVERABLES

- 2.1. Submit one electronic copy in PDF format (emailed or on CD) of each final deliverable to Sonoma Water.
- 2.2. Comply with requirements of Paragraph 11 (Content Online Accessibility).

Exhibit B

Schedule of Costs

Staff	Rate
Consultant	\$180
Expenses	Cost
Administrative assistance	At cost
In-house copies	\$0.10 per page
Outside copies	At cost
Postage	At cost
Overnight mail	At cost
Mileage for personal car	IRS rate
Travel expenses, including: <ul style="list-style-type: none">• car rental, daily rate• meals and lodging as pre-approved by Sonoma Water Project Manager• airfare to attend workshops, conferences, and/or other meetings requested by Sonoma Water Project Manager	At cost

Exhibit C

Estimated Budget for Scope of Work

Task	Estimated Budget
1. AQPI Project Coordination	\$41,000
2. Grant Management Assistance	\$41,000
3. Siting and Permitting Assistance	\$62,000
4. Public Outreach	\$62,000
5. Monthly Reporting	\$20,000
6. Optional	\$20,000
Travel	\$3,000
Expenses	\$1,000
Total	\$250,000

Exhibit D

Grant Award Documents

Grant Agreement No. 4600011485
Page 19 of 35

EXHIBIT D STANDARD CONDITIONS

D.1) **ACCOUNTING AND DEPOSIT OF FUNDING DISBURSEMENT:**

- a) Separate Accounting of Funding Disbursements and Interest Records: Grantee shall account for the money disbursed pursuant to this Grant Agreement separately from all other Grantee funds. Grantee shall maintain audit and accounting procedures that are in accordance with generally accepted accounting principles and practices, consistently applied. Grantee shall keep complete and accurate records of all receipts, disbursements, and interest earned on expenditures of such funds. Grantee shall require its contractors or subcontractors to maintain books, records, and other documents pertinent to their work in accordance with generally accepted accounting principles and practices. Records are subject to inspection by State at any and all reasonable times.
- b) Fiscal Management Systems and Accounting Standards: The Grantee agrees that, at a minimum, its fiscal control and accounting procedures will be sufficient to permit tracing of grant funds to a level of expenditure adequate to establish that such funds have not been used in violation of state law or this Grant Agreement.
- c) Disposition of Money Disbursed: All money disbursed pursuant to this Grant Agreement shall be deposited, administered, and accounted for pursuant to the provisions of applicable law.
- d) Remittance of Unexpended Funds: Grantee shall remit to State any unexpended funds that were disbursed to Grantee under this Grant Agreement and were not used to pay Eligible Project Costs within a period of sixty (60) calendar days from the final disbursement from State to Grantee of funds or, within thirty (30) calendar days of the expiration of the Grant Agreement, whichever comes first.

D.2) **ACKNOWLEDGEMENT OF CREDIT:** Grantee shall include appropriate acknowledgement of credit to the State and to all cost-sharing partners for their support when promoting the Project or using any data and/or information developed under this Grant Agreement. During construction of the project, Grantee shall install a sign at a prominent location, which shall include a statement that the project is financed under the Safe Drinking Water, Water Quality and Supply, Flood Control, River and Coastal Protection Bond Act of 2006, administered by State of California, Department of Water Resources. Grantee shall notify State that the sign has been erected by providing them with a site map with the sign location noted and a photograph of the sign.

D.3) **AIR OR WATER POLLUTION VIOLATION:** Under State laws, the Grantee shall not be: (1) in violation of any order or resolution not subject to review promulgated by the State Air Resources Board or an air pollution control district; (2) subject to cease and desist order not subject to review issued pursuant to §13301 of the Water Code for violation of waste discharge requirements or discharge prohibitions; or (3) finally determined to be in violation of provisions of federal law relating to air or water pollution.

D.4) **AMENDMENT:** This Grant Agreement may be amended at any time by mutual agreement of the Parties, except insofar as any proposed amendments are in any way contrary to applicable law. Requests by the Grantee for amendments must be in writing stating the amendment request and the reason for the request. State shall have no obligation to agree to an amendment.

D.5) **AMERICANS WITH DISABILITIES ACT:** By signing this Grant Agreement, Grantee assures State that it complies with the Americans with Disabilities Act (ADA) of 1990, (42 U.S.C., 12101 et seq.), which prohibits discrimination on the basis of disability, as well as all applicable regulations and guidelines issued pursuant to the ADA.

D.6) **APPROVAL:** This Agreement is of no force or effect until signed by all parties to the agreement. Grantee may not submit invoices or receive payment until all required signatures have been obtained.

D.7) **AUDITS:** State reserves the right to conduct an audit at any time between the execution of this Grant Agreement and the completion of the Project, with the costs of such audit borne by State. After completion of the Project, State may require Grantee to conduct a final audit to State's specifications, at Grantee's expense, such audit to be conducted by and a report prepared by an independent

Certified Public Accountant. Failure or refusal by Grantee to comply with this provision shall be considered a breach of this Grant Agreement, and State may elect to pursue any remedies provided in Paragraph 14 or take any other action it deems necessary to protect its interests.

Pursuant to Government Code §8546.7, the Grantee shall be subject to the examination and audit by the State for a period of three years after final payment under this Grant Agreement with respect to all matters connected with this Grant Agreement, including but not limited to, the cost of administering this Grant Agreement. All records of Grantee or its contractor or subcontractors shall be preserved for this purpose for at least three (3) years after project completion or final billing, whichever comes later.

- D.8) BUDGET CONTINGENCY:** If the Budget Act of the current year covered under this Grant Agreement does not appropriate sufficient funds for the Proposition 84 Implementation Grant Program, this Grant Agreement shall be of no force and effect. This provision shall be construed as a condition precedent to the obligation of State to make any payments under this Grant Agreement. In this event, State shall have no liability to pay any funds whatsoever to Grantee or to furnish any other considerations under this Grant Agreement and Grantee shall not be obligated to perform any provisions of this Grant Agreement. Nothing in this Grant Agreement shall be construed to provide Grantee with a right of priority for payment over any other Grantee. If funding for any fiscal year after the current year covered by this Grant Agreement is reduced or deleted by the Budget Act for purposes of this program, State shall have the option to either cancel this Grant Agreement with no liability occurring to State, or offer a Grant Agreement amendment to Grantee to reflect the reduced amount.
- D.9) CALIFORNIA CONSERVATION CORPS:** As required in Water Code §79038(b), Grantee shall examine the feasibility of using the California Conservation Corps or community conservation corps to accomplish the habitat restoration, enhancement and protection activities listed in the Exhibit A, Work Plan, and shall use the services of one of these organizations whenever feasible.
- D.10) CEQA:** Activities funded under this Grant Agreement, regardless of funding source, must be in compliance with the California Environmental Quality Act (CEQA) (Public Resources Code §21000 et seq.). Information on CEQA may be found at the following links:
Environmental Information: <http://resources.ca.gov/ceqa/>
California State Clearinghouse Handbook:
https://www.opr.ca.gov/docs/SCH_Handbook_2012.pdf
- D.11) CHILD SUPPORT COMPLIANCE ACT:** For any Grant Agreement in excess of \$100,000, the Grantee acknowledges in accordance with Public Contract Code §7110, that:
- a) The Grantee recognizes the importance of child and family support obligations and shall fully comply with all applicable state and federal laws relating to child and family support enforcement, including, but not limited to, disclosure of information and compliance with earnings assignment orders, as provided in Chapter 8 (commencing with §5200) of Part 5 of Division 9 of the Family Code; and
 - b) The Grantee, to the best of its knowledge is fully complying with the earnings assignment orders of all employees and is providing the names of all new employees to the New Hire Registry maintained by the California Employment Development Department.
- D.12) CLAIMS DISPUTE:** Any claim that the Grantee may have regarding performance of this agreement including, but not limited to, claims for additional compensation or extension of time, shall be submitted to the State's Project Manager, within thirty (30) calendar days of the Grantee's knowledge of the claim. State and Grantee shall then attempt to negotiate a resolution of such claim and process an amendment to this Agreement to implement the terms of any such resolution.
- D.13) COMPETITIVE BIDDING AND PROCUREMENTS:** Grantee shall comply with all applicable laws and regulations regarding securing competitive bids and undertaking competitive negotiations in Grantee's contracts with other entities for acquisition of goods and services and construction of public works with funds provided by State under this Grant Agreement.

- D.14) COMPUTER SOFTWARE:** Grantee certifies that it has appropriate systems and controls in place to ensure that state funds will not be used in the performance of this Grant Agreement for the acquisition, operation, or maintenance of computer software in violation of copyright laws.
- D.15) CONFLICT OF INTEREST:** All participants are subject to State and Federal conflict of interest laws. Failure to comply with these laws, including business and financial disclosure provisions, will result in the application being rejected and any subsequent contract being declared void. Other legal action may also be taken. Applicable statutes include, but are not limited to, Government Code, § 1090 and Public Contract Code, § 10410 and § 10411, for State conflict of interest requirements.
- a) **Current State Employees:** No State officer or employee shall engage in any employment, activity, or enterprise from which the officer or employee receives compensation or has a financial interest and which is sponsored or funded by any State agency, unless the employment, activity, or enterprise is required as a condition of regular State employment. No State officer or employee shall contract on his or her own behalf as an independent contractor with any State agency to provide goods or services.
 - b) **Former State Employees:** For the two-year period from the date he or she left State employment, no former State officer or employee may enter into a contract in which he or she engaged in any of the negotiations, transactions, planning, arrangements, or any part of the decision-making process relevant to the contract while employed in any capacity by any State agency. For the twelve-month period from the date he or she left State employment, no former State officer or employee may enter into a contract with any State agency if he or she was employed by that State agency in a policy-making position in the same general subject area as the proposed contract within the twelve-month period prior to his or her leaving State service.
 - c) **Employees of the Grantee:** Employees of the Grantee shall comply with all applicable provisions of law pertaining to conflicts of interest, including but not limited to any applicable conflict of interest provisions of the California Political Reform Act, Government Code § 87100 *et seq.*
 - d) **Employees and Consultants to the Grantee:** Individuals working on behalf of a Grantee may be required by the Department to file a Statement of Economic Interests (Fair Political Practices Commission Form 700) if it is determined that an individual is a consultant for Political Reform Act purposes.
- D.16) DELIVERY OF INFORMATION, REPORTS, AND DATA:** Grantee agrees to expeditiously provide throughout the term of this Grant Agreement, such reports, data, information, and certifications as may be reasonably required by State.
- D.17) DISPOSITION OF EQUIPMENT:** Grantee shall provide to State, not less than 30 calendar days prior to submission of the final invoice, an itemized inventory of equipment purchased with funds provided by State. The inventory shall include all items with a current estimated fair market value of more than \$5,000.00 per item. Within 60 calendar days of receipt of such inventory State shall provide Grantee with a list of the items on the inventory that State will take title to. All other items shall become the property of Grantee. State shall arrange for delivery from Grantee of items that it takes title to. Cost of transportation, if any, shall be borne by State.
- D.18) DRUG-FREE WORKPLACE CERTIFICATION:** Certification of Compliance: By signing this Grant Agreement, Grantee, its contractors or subcontractors hereby certify, under penalty of perjury under the laws of State of California, compliance with the requirements of the Drug-Free Workplace Act of 1990 (Government Code § 8350 *et seq.*) and have or will provide a drug-free workplace by taking the following actions:
- a) Publish a statement notifying employees, contractors, and subcontractors that unlawful manufacture, distribution, dispensation, possession, or use of a controlled substance is prohibited and specifying actions to be taken against employees, contractors, or subcontractors for violations, as required by Government Code § 8355(a)(1).

- b) Establish a Drug-Free Awareness Program, as required by Government Code §8355(a)(2) to inform employees, contractors, or subcontractors about all of the following:
 - i) The dangers of drug abuse in the workplace,
 - ii) Grantee's policy of maintaining a drug-free workplace,
 - iii) Any available counseling, rehabilitation, and employee assistance programs, and
 - iv) Penalties that may be imposed upon employees, contractors, and subcontractors for drug abuse violations.
 - c) Provide, as required by Government Code §8355(a)(3), that every employee, contractor, and/or subcontractor who works under this Grant Agreement:
 - i) Will receive a copy of Grantee's drug-free policy statement, and
 - ii) Will agree to abide by terms of Grantee's condition of employment, contract or subcontract.
- D.19) FINAL INSPECTIONS AND CERTIFICATION OF REGISTERED PROFESSIONAL:** Upon completion of the Project, Grantee shall provide for a final inspection and certification by the appropriate registered professional (California Registered Civil Engineer or Geologist) that the Project has been completed in accordance with submitted final plans and specifications and any modifications thereto and in accordance with this Grant Agreement. Grantee shall notify the State's Project Manager of the inspection date at least 14 calendar days prior to the inspection in order to provide State the opportunity to participate in the inspection.
- D.20) GRANTEE COMMITMENTS:** Grantee accepts and agrees to comply with all terms, provisions, conditions and commitments of this Grant Agreement, including all incorporated documents, and to fulfill all assurances, declarations, representations, and statements made by the Grantee in the application, documents, amendments, and communications filed in support of its request for funding.
- D.21) GRANTEE NAME CHANGE:** Approval of the State's Program Manager is required to change the Grantee's name as listed on this Grant Agreement. Upon receipt of legal documentation of the name change the State will process an amendment. Payment of invoices presented with a new name cannot be paid prior to approval of said amendment.
- D.22) GOVERNING LAW:** This Grant Agreement is governed by and shall be interpreted in accordance with the laws of the State of California.
- D.23) INDEMNIFICATION:** Grantee shall indemnify and hold and save the State, its officers, agents, and employees, free and harmless from any and all liabilities for any claims and damages (including inverse condemnation) that may arise out of the Project and this Agreement, including, but not limited to any claims or damages arising from planning, design, construction, maintenance and/or operation of levee rehabilitation measures for this Project and any breach of this Agreement. Grantee shall require its contractors or subcontractors to name the State, its officers, agents and employees as additional insured on their liability insurance for activities undertaken pursuant to this Agreement.
- D.24) INDEPENDENT CAPACITY:** Grantee, and the agents and employees of Grantees, in the performance of the Grant Agreement, shall act in an independent capacity and not as officers, employees, or agents of the State.
- D.25) INSPECTION OF BOOKS, RECORDS, AND REPORTS:** During regular office hours, each of the parties hereto and their duly authorized representatives shall have the right to inspect and to make copies of any books, records, or reports of either party pertaining to this Grant Agreement or matters related hereto. Each of the parties hereto shall maintain and shall make available at all times for such inspection accurate records of all its costs, disbursements, and receipts with respect to its activities under this Grant Agreement. Failure or refusal by Grantee to comply with this provision shall be considered a breach of this Grant Agreement, and State may withhold disbursements to Grantee or take any other action it deems necessary to protect its interests.
- D.26) INSPECTIONS OF PROJECT BY STATE:** State shall have the right to inspect the work being performed at any and all reasonable times during the term of the Grant Agreement. This right shall extend to any subcontracts, and Grantee shall include provisions ensuring such access in all its contracts or subcontracts entered into pursuant to its Grant Agreement with State.

- D.27) INVOICE DISPUTES:** In the event of an invoice dispute, payment will not be made until the dispute is resolved and a corrected invoice submitted. Failure to use the address exactly as provided may result in return of the invoice to the Grantee. Payment shall be deemed complete upon deposit of the payment, properly addressed, postage prepaid, in the United States mail. Any claim that Grantee may have regarding the performance of this Grant Agreement including, but not limited to claims for additional compensation or extension of time, shall be submitted to the DWR Project Manager within thirty (30) calendar days of Grantee's knowledge of the claim. State and Grantee shall then attempt to negotiate a resolution of such claim and process an amendment to the Grant Agreement to implement the terms of any such resolution.
- D.28) LABOR CODE COMPLIANCE:** The Grantee will be required to keep informed of and take all measures necessary to ensure compliance with applicable Labor Code requirements, including, but not limited to, §1720 *et seq.* of the Labor Code regarding public works, limitations on use of volunteer labor (Labor Code §1720.4), labor compliance programs (Labor Code §1771.5) and payment of prevailing wages for work done and funded pursuant to these Guidelines, including any payments to the Department of Industrial Relations under Labor Code §1771.3.
- D.29) NONDISCRIMINATION:** During the performance of this Grant Agreement, Grantee and its contractors or subcontractors shall not unlawfully discriminate, harass, or allow harassment against any employee or applicant for employment because of sex (gender), sexual orientation, race, color, ancestry, religion, creed, national origin (including language use restriction), pregnancy, physical disability (including HIV and AIDS), mental disability, medical condition (cancer/genetic characteristics), age (over 40), marital status, and denial of medial and family care leave or pregnancy disability leave. Grantee and its contractors or subcontractors shall ensure that the evaluation and treatment of their employees and applicants for employment are free from such discrimination and harassment. Grantee and its contractors or subcontractors shall comply with the provisions of the Fair Employment and Housing Act (Government Code §12990 (a-f) *et seq.*) and the applicable regulations promulgated there under (California Code of Regulations, Title 2, §7285 *et seq.*). The applicable regulations of the Fair Employment and Housing Commission implementing Government Code §12990 (a-f), set forth in Chapter 5 of Division 4 of Title 2 of the California Code of Regulations, are incorporated into this Agreement by reference and made a part hereof as if set forth in full. Grantee and its contractors or subcontractors shall give written notice of their obligations under this clause to labor organizations with which they have a collective bargaining or other agreement.
- Grantee shall include the nondiscrimination and compliance provisions of this clause in all subcontracts to perform work under the Grant Agreement.
- D.30) NO DISCRIMINATION AGAINST DOMESTIC PARTNERS:** For contracts over \$100,000 executed or amended after January 1, 2007, the Grantee certifies by signing this Grant Agreement, under penalty of perjury under the laws of State of California that Grantee is in compliance with Public Contract Code §10295.3.
- D.31) OPINIONS AND DETERMINATIONS:** Where the terms of this Grant Agreement provide for action to be based upon, judgment, approval, review, or determination of either party hereto, such terms are not intended to be and shall never be construed as permitting such opinion, judgment, approval, review, or determination to be arbitrary, capricious, or unreasonable.
- D.32) PERFORMANCE AND ASSURANCES:** Grantee agrees to faithfully and expeditiously perform or cause to be performed all Project work as described in Exhibit A (Work Plan) and to apply State funds received only to Eligible Project Costs in accordance with applicable provisions of the law.
- D.33) PRIORITY HIRING CONSIDERATIONS:** If this Grant Agreement includes services in excess of \$200,000, the Grantee shall give priority consideration in filling vacancies in positions funded by the Grant Agreement to qualified recipients of aid under Welfare and Institutions Code §11200 in accordance with Public Contract Code §10353.
- D.34) PROHIBITION AGAINST DISPOSAL OF PROJECT WITHOUT STATE PERMISSION:** The Grantee shall not sell, abandon, lease, transfer, exchange, mortgage, hypothecate, or encumber in any manner whatsoever all or any portion of any real or other property necessarily connected or used in conjunction with the

Project, or with Grantee's service of water, without prior permission of State. Grantee shall not take any action, including but not limited to actions relating to user fees, charges, and assessments that could adversely affect the ability of Grantee to meet its obligations under this Grant Agreement, without prior written permission of State. State may require that the proceeds from the disposition of any real or personal property be remitted to State.

- D.35) REMEDIES NOT EXCLUSIVE:** The use by either party of any remedy specified herein for the enforcement of this Grant Agreement is not exclusive and shall not deprive the party using such remedy of, or limit the application of, any other remedy provided by law.
- D.36) RETENTION:** Notwithstanding any other provision of this Grant Agreement, State shall, for each project, withhold five percent (5.0%) until January 1, 2018 and ten percent (10.0%), thereafter, of the funds requested by Grantee for reimbursement of Eligible Costs. Each project in this Grant Agreement will be eligible to release its respective retention when that project is completed and Grantee has met requirements of Paragraph 19, "Submissions of Reports", except in the case of the last project to be completed under this Grant Agreement, in which case retention for such project will not be disbursed until the "Grant Completion Report" is submitted to and approved by State. State shall disburse retained funds to the Grantee.
- D.37) RIGHTS IN DATA:** Grantee agrees that all data, plans, drawings, specifications, reports, computer programs, operating manuals, notes and other written or graphic work produced in the performance of this Grant Agreement shall be made available to the State and shall be in the public domain to the extent to which release of such materials is required under the California Public Records Act., Government Code §6250 *et seq.* Grantee may disclose, disseminate and use in whole or in part, any final form data and information received, collected and developed under this Grant Agreement, subject to appropriate acknowledgement of credit to State for financial support. Grantee shall not utilize the materials for any profit-making venture or sell or grant rights to a third party who intends to do so. The State shall have the right to use any data described in this paragraph for any public purpose.
- D.38) SEVERABILITY:** Should any portion of this Grant Agreement be determined to be void or unenforceable, such shall be severed from the whole and the Grant Agreement shall continue as modified.
- D.39) STATE REVIEWS:** The parties agree that review or approval of the project application, documents, permits, plans, and specifications or other project information by the State is for administrative purposes only and does not relieve the Grantee of their responsibility to properly plan, design, construct, operate, maintain, implement, or otherwise carry out the project.
- D.40) SUSPENSION OF PAYMENTS:** This Grant Agreement may be subject to suspension of payments or termination, or both, and Grantee may be subject to debarment if the State determines that:
- a) Grantee, its contractors, or subcontractors have made a false certification, or
 - b) Grantee, its contractors, or subcontractors violates the certification by failing to carry out the requirements noted in this Grant Agreement.
- D.41) SUCCESSORS AND ASSIGNS:** This Grant Agreement and all of its provisions shall apply to and bind the successors and assigns of the parties. No assignment or transfer of this Grant Agreement or any part thereof, rights hereunder, or interest herein by the Grantee shall be valid unless and until it is approved by State and made subject to such reasonable terms and conditions as State may impose.
- D.42) TERMINATION BY GRANTEE:** Subject to State approval which may be reasonably withheld, Grantee may terminate this Agreement and be relieved of contractual obligations. In doing so, Grantee must provide a reason(s) for termination. Grantee must submit all progress reports summarizing accomplishments up until termination date.
- D.43) TERMINATION FOR CAUSE:** Subject to the right to cure under Paragraph 14, the State may terminate this Grant Agreement and be relieved of any payments should Grantee fail to perform the requirements of this Grant Agreement at the time and in the manner herein, provided including but not limited to reasons of default under Paragraph 14.

- D.44) TERMINATION WITHOUT CAUSE:** The State may terminate this Grant Agreement without cause on 30 calendar days advance written notice. The Grantee shall be reimbursed for all reasonable expenses incurred up to the date of termination.
- D.45) THIRD PARTY BENEFICIARIES:** The parties to this Grant Agreement do not intend to create rights in, or grant remedies to, any third party as a beneficiary of this Agreement, or any duty, covenant, obligation or understanding established herein.
- D.46) TIMELINESS:** Time is of the essence in this Grant Agreement.
- D.47) TRAVEL:** Grantee agrees that travel and per diem costs shall NOT be eligible for reimbursement with State funds, and shall NOT be eligible for computing Grantee cost match. Travel includes the costs of transportation, subsistence, and other associated costs incurred by personnel during the term of this Grant Agreement.
- D.48) WAIVER OF RIGHTS:** None of the provisions of this Grant Agreement shall be deemed waived unless expressly waived in writing. It is the intention of the parties here to that from time to time either party may waive any of its rights under this Grant Agreement unless contrary to law. Any waiver by either party of rights arising in connection with the Grant Agreement shall not be deemed to be a waiver with respect to any other rights or matters, and such provisions shall continue in full force and effect.
- D.49) WORKERS' COMPENSATION:** Grantee affirms that it is aware of the provisions of §3700 of the Labor Code, which requires every employer to be insured against liability for workers' compensation or to undertake self-insurance in accordance with the provisions of that code, and Grantee affirms that it will comply with such provisions before commencing the performance of the work under this Grant Agreement and will make its contractors and subcontractors aware of this provision.

Exhibit E

Insurance Requirements

With respect to performance of work under this Agreement, Consultant shall maintain and shall require all of its subcontractors, consultants, and other agents to maintain insurance as described below unless such insurance has been expressly waived by the attachment of a *Waiver of Insurance Requirements*. Any requirement for insurance to be maintained after completion of the work shall survive this Agreement.

Sonoma Water reserves the right to review any and all of the required insurance policies and/or endorsements, but has no obligation to do so. Failure to demand evidence of full compliance with the insurance requirements set forth in this Agreement or failure to identify any insurance deficiency shall not relieve Consultant from, nor be construed or deemed a waiver of, its obligation to maintain the required insurance at all times during the performance of this Agreement.

1. INSURANCE

- 1.1. Workers Compensation and Employers Liability Insurance
 - a. Required if Consultant has employees.
 - b. Workers Compensation insurance with statutory limits as required by the Labor Code of the State of California.
 - c. Employers Liability with minimum limits of \$1,000,000 per Accident; \$1,000,000 Disease per employee; \$1,000,000 Disease per policy.
 - d. Required Evidence of Insurance: Certificate of Insurance.
 - e. If Consultant currently has no employees, Consultant agrees to obtain the above-specified Workers Compensation and Employers' Liability insurance should employees be engaged during the term of this Agreement or any extensions of the term.
- 1.2. General Liability Insurance
 - a. Commercial General Liability Insurance on a standard occurrence form, no less broad than Insurance Services Office (ISO) form CG 00 01.
 - b. Minimum Limits: \$1,000,000 per Occurrence; \$2,000,000 General Aggregate; \$2,000,000 Products/Completed Operations Aggregate. The required limits may be provided by a combination of General Liability Insurance and Commercial Excess or Commercial Umbrella Liability Insurance. If Consultant maintains higher limits than the specified minimum limits, Sonoma Water requires and shall be entitled to coverage for the higher limits maintained by Consultant.
 - c. Any deductible or self-insured retention shall be shown on the Certificate of Insurance. If the deductible or self-insured retention exceeds \$25,000 it must be approved in advance by Sonoma Water. Consultant is responsible

for any deductible or self-insured retention and shall fund it upon Sonoma Water's written request, regardless of whether Consultant has a claim against the insurance or is named as a party in any action involving Sonoma Water.

- d. Sonoma County Water Agency, its officers, agents, and employees, shall be endorsed as additional insureds for liability arising out of operations by or on behalf of the Consultant in the performance of this Agreement.
- e. The insurance provided to the additional insureds shall be primary to, and non-contributory with, any insurance or self-insurance program maintained by them.
- f. The policy definition of "insured contract" shall include assumptions of liability arising out of both ongoing operations and the products-completed operations hazard (broad form contractual liability coverage including the "f" definition of insured contract in Insurance Services Office form CG 00 01, or equivalent).
- g. The policy shall cover inter-insured suits between the additional insureds and Consultant and include a "separation of insureds" or "severability" clause which treats each insured separately.
- h. Required Evidence of Insurance:
 - i. Copy of the additional insured endorsement or policy language granting additional insured status, and
 - ii. Certificate of Insurance.

1.3. Automobile Liability Insurance

- a. Minimum Limit: \$300,000 Combined Single Limit per Accident; or Bodily Injury: \$100,000 per person/\$300,000 per accident and Property Damage: \$50,000 per accident.
- b. Required Evidence of Insurance:
 - i. Copy of Auto Policy Declarations Page; or
 - ii. Certificate of Insurance.

1.4. Standards for Insurance Companies

- a. Insurers, other than the California State Compensation Insurance Fund, shall have an A.M. Best's rating of at least A:VII.

1.5. Documentation

- a. The Certificate of Insurance must include the following reference: TW 18/19-002.
- b. All required Evidence of Insurance shall be submitted prior to the execution of this Agreement. Consultant agrees to maintain current Evidence of Insurance on file with Sonoma Water for the entire term of this Agreement and any additional periods if specified in Sections 1.1, 1.2, or 1.3, above.

- c. The name and address for mailing Additional Insured endorsements and Certificates of Insurance is: Sonoma County Water Agency, 404 Aviation Boulevard, Santa Rosa, CA 95403-9019.
- d. Required Evidence of Insurance shall be submitted for any renewal or replacement of a policy that already exists, at least ten (10) days before expiration or other termination of the existing policy.
- e. Consultant shall provide immediate written notice if: (1) any of the required insurance policies is terminated; (2) the limits of any of the required policies are reduced; or (3) the deductible or self-insured retention is increased.
- f. Upon written request, certified copies of required insurance policies must be provided within thirty (30) days.

1.6. Policy Obligations

- a. Consultant's indemnity and other obligations shall not be limited by the foregoing insurance requirements.

1.7. Material Breach

- a. If Consultant fails to maintain insurance which is required pursuant to this Agreement, it shall be deemed a material breach of this Agreement. Sonoma Water, at its sole option, may terminate this Agreement and obtain damages from Consultant resulting from said breach. Alternatively, Sonoma Water may purchase the required insurance, and without further notice to Consultant, Sonoma Water may deduct from sums due to Consultant any premium costs advanced by Sonoma Water for such insurance. These remedies shall be in addition to any other remedies available to Sonoma Water.

Exhibit F

Waiver of Insurance Requirements



Exhibit F Waiver of Insurance Requirements

This Exhibit modifies the insurance requirements as specified in Exhibit E

Department	<u>Sonoma Water</u>	Department Contact	<u>Jake Spaulding</u>	Phone	<u>524-8373</u>
Contractor, Consultant, Vendor, Licensee, Tenant		<u>Jennifer Krebs dba Jennifer Krebs Environmental Planning</u>			
Contact Person	<u>Jennifer Krebs</u>	Phone	<u>510-393-7878</u>		
Contract Term	<u>12/31/21</u>	Contract Cost	<u>\$250,000</u>	Template #	<u>4</u>
Was there an RFP/RFQ or other competitive process for this agreement? Yes <input type="checkbox"/> No <input checked="" type="checkbox"/>					
If yes, was an exception to the Insurance Requirements noted in the Vendor's proposal? Yes <input type="checkbox"/> No <input type="checkbox"/>					

- ◆ If only Section I waivers are required, submit to your Department Head or designee for signature. Do not submit to Risk.
- ◆ If only Section II waivers, or a combination of Section I and II waivers, are required, submit to Risk.

Section I - Department Waivers – (Must be designated “Department Waiver” in the Template Assistant)

Requirement to be Waived and Reason

- Workers Compensation: Waive Subrogation Waiver.
- General Liability: Waive General Aggregate per location or per project; General Aggregate is at least double the Occurrence Limit.
- General Liability: Waive requirement for Subrogation Waiver because insurer will not provide the coverage.
- General Liability (Suppliers of Products): Waive “Additional Insured – Vendors”. County does not distribute the product to the public.
- General Liability (Special Events): Waive Products/Completed Operations Coverage. Licensee will not sell or distribute food or other tangible items at the event.
- General Liability (Instructors/Trainers): Waive General Liability. Training does not involve the use of hazardous equipment, participation in physical activity, or medical training.
- General Liability (Therapists, Counselors, Social Workers and Psychologists): Waive General Liability. All services are provided in the consultant's office or on County premises and acceptable evidence of professional liability insurance has been provided.
- Auto Liability: Waive coverage and/or limits. Consultant or Contractor does no driving on behalf of the County or the driving is limited to attendance at meetings at County/Entity facilities.
- Auto Liability (Suppliers of Products): Waive coverage because vendor's goods are delivered by common carrier or contract carrier.
- Property Insurance (Long Term Tenants): Waive Property Insurance requirement. Tenant has not made improvements to the property or the current construction cost of the improvements is less than \$25,000.
- Mold Liability: Landlord cannot obtain the insurance.
- Standards for Insurance Companies: Waive A.M. Best's rating requirement.

Approved by Department Head, Department Designee or Risk Management

Date

Waiver of Insurance Requirements (fillable form)

Ver. 07/23/2018

Page 1 of 2

Section II - Risk Management Waivers

Submit to Risk with the agreement including the Scope of Work.

General Liability Waivers

- Waive requirement for coverage
Reason: Reduce Products/Completed Operations Aggregate from \$2M to \$1M. Carrier will not cover \$2M.
- Waive requirement for additional insured endorsement
Reason: _____
- Waive primary & non-contributory language (if evidence is required)
Reason: _____

Auto Liability Waivers

- Accept lower limits
Reason: _____
- Waive hired & non-owned auto liability
Reason: _____

Workers Compensation Waivers

- Waive requirement for subrogation waiver endorsement (if required)
Reason: _____

Professional Liability Waivers

- Waive requirement for coverage
Reason: _____
- Accept lower limits
Reason: _____

Pollution Liability Waivers

- Waive requirement for coverage
Reason: _____
- Accept lower limits
Reason: _____
- Waive requirement for additional insured endorsement
Reason: _____

Other Waivers

- Describe: _____
Reason: _____

Larry Moss
Approved by Risk Management

8/28/2018
Date



Agreement for Stakeholder Outreach Coordination Related to the Advanced Quantitative Precipitation Information System

This agreement (“Agreement”) is by and between **Sonoma County Water Agency**, a body corporate and politic of the State of California (“Sonoma Water”) and **Bay Planning Coalition**, a non-profit California corporation (“Consultant”). The Effective Date of this Agreement is the date the Agreement is last signed by the parties to the Agreement, unless otherwise specified in Paragraph 5.1.

RECITALS

- A. Consultant represents that it is a duly qualified advocacy and facilitation firm, experienced in stakeholder outreach and related services.
- B. The San Francisco Bay Area Advanced Quantitative Precipitation Information (“AQPI”) System project is financed under Grant Agreement No. 4600011485 (“Grant”) that is funded by the Safe Drinking Water, Water Quality and Supply, Flood Control, River and Coastal Protection Bond Act of 2006, administered by the State of California, Department of Water Resources (“DWR”).
- C. Sonoma Water, acting as grantee and lead administrative agency, will manage administration for the AQPI project including contracting with the Department of Water Resources and project partners.
- D. The National Ocean and Atmospheric Administration (“NOAA”), acting as the Project Director, will direct technical aspects of the project, in conjunction with the Technical Advisory Committee (TAC), including coordinating work with Consultant.
- E. The AQPI TAC is comprised of stakeholders such as NOAA; Colorado State University’s Cooperative Institute for Research in the Atmosphere (“CIRA”); Scripps Institute of Oceanography’s Center for Western Weather and Water Extremes (“CW3E”); the United States Geological Survey (“USGS”); Consultant; and the Local Project Partners that include, but are not limited to, Sonoma Water, San Francisco Public Utilities Commission, Santa Clara Valley Water District, and the Bay Area Flood Protection Agencies Association.
- F. The AQPI Project Management Team will consist of Sonoma Water, Consultant, NOAA, CIRA, CW3E, USGS, and others, as needed.
- G. Sonoma Water needs Consultant’s expertise and experience for work on the AQPI System.

In consideration of the foregoing recitals and the mutual covenants contained herein, the parties hereto agree as follows:

A G R E E M E N T

1. RECITALS

1.1. The above recitals are true and correct.

2. LIST OF EXHIBITS

2.1. The following exhibits are attached hereto and incorporated herein:

- a. Exhibit A: Scope of Work
- b. Exhibit B: Schedule of Costs
- c. Exhibit C: Estimated Budget for Scope of Work
- d. Exhibit D: Grant Award Documents
- e. Exhibit E: Insurance Requirements

3. SCOPE OF SERVICES

3.1. *Consultant's Specified Services:* Consultant shall perform the services described in Exhibit A (Scope of Work), within the times or by the dates provided for in Exhibit A and pursuant to Article 9 (Prosecution of Work). In the event of a conflict between the body of this Agreement and Exhibit A, the provisions in the body of this Agreement shall control.

3.2. *Cooperation with Sonoma Water:* Consultant shall cooperate with Sonoma Water in the performance of all work hereunder. Consultant shall coordinate the work with Sonoma Water's Project Manager. Contact information and mailing addresses:

Sonoma Water	Consultant
Project Manager: Jake Spaulding 404 Aviation Boulevard Santa Rosa, CA 95403-9019 Phone: 707-524-8373 Email: Jake.Spaulding@scwa.ca.gov	Contact: John A. Coleman 1970 Broadway, Suite 940 Oakland, CA 94612 Phone: 510-768-8310 Email: john@bayplanningcoalition.org
Remit invoices to:	Remit payments to:
Susan Bookmyer Same address as above or Email: susan.bookmyer@scwa.ca.gov	Same as above.

3.3. *Performance Standard and Standard of Care:* Consultant hereby agrees that all its work will be performed and that its operations shall be conducted in accordance with the standards of a reasonable professional having specialized knowledge and expertise in the services provided under this Agreement and in accordance with all applicable federal, state and local laws, it being understood that acceptance of Consultant's work by Sonoma Water shall not operate as a

waiver or release. Sonoma Water has relied upon the professional ability and training of Consultant as a material inducement to enter into this Agreement. If Sonoma Water determines that any of Consultant’s work is not in accordance with such level of competency and standard of care, Sonoma Water, in its sole discretion, shall have the right to do any or all of the following: (a) require Consultant to meet with Sonoma Water to review the quality of the work and resolve matters of concern; (b) require Consultant to repeat the work at no additional charge until it is satisfactory; (c) terminate this Agreement pursuant to the provisions of Article 6 (Termination); or (d) pursue any and all other remedies at law or in equity.

3.4. *Assigned Personnel:*

- a. Consultant shall assign only competent personnel to perform work hereunder. In the event that at any time Sonoma Water, in its sole discretion, desires the removal of any person or persons assigned by Consultant to perform work hereunder, Consultant shall remove such person or persons immediately upon receiving written notice from Sonoma Water.
- b. Any and all persons identified in this Agreement or any exhibit hereto as the project manager, project team, or other professional performing work hereunder are deemed by Sonoma Water to be key personnel whose services were a material inducement to Sonoma Water to enter into this Agreement, and without whose services Sonoma Water would not have entered into this Agreement. Consultant shall not remove, replace, substitute, or otherwise change any key personnel without the prior written consent of Sonoma Water.
- c. With respect to performance under this Agreement, Consultant shall employ the following key personnel:

<i>Title</i>	<i>Name</i>
Chief Executive Officer	John A Coleman

- d. In the event that any of Consultant’s personnel assigned to perform services under this Agreement become unavailable due to resignation, sickness, or other factors outside of Consultant’s control, Consultant shall be responsible for timely provision of adequately qualified replacements.

4. PAYMENT

4.1. *Total Costs:* Total costs under this Agreement shall not exceed \$300,000.

- a. Total costs for Tasks 1-6 shall not exceed \$290,000.
- b. Total costs for Optional Task 7, if requested in writing by Sonoma Water, shall not exceed \$10,000.

4.2. *Method of Payment:* Consultant shall be paid in accordance with the following terms:

- a. Consultant shall be paid in accordance with Exhibit B (Schedule of Costs). Consultant acknowledges and agrees that travel and per diem costs are not

allowable costs under the Grant Agreement between DWR and Sonoma Water. Travel includes the costs of transportation, subsistence, and other associated costs incurred by personnel during the term of this Agreement. Consultant shall be reimbursed for pre-approved travel and per diem costs if billed under a separate task number. Labor time while traveling is a reimbursable cost under the Grant.

- b. Retention:
 - i. State of California is withholding 10% of each invoice as retention, amounting to 10% of the total Agreement.
 - ii. Payments made by Sonoma Water to Consultant are subject to this 10% retention.
 - iii. Retention amounts will be released by Sonoma Water to Consultant upon acceptance of Grant Completion Report by State of California.

- 4.3. *Invoices:* Consultant shall submit its bills in arrears on a monthly basis, based on work completed for the period, in a form approved by Sonoma Water. The bills shall show or include:
 - a. Consultant name
 - b. Name of Agreement
 - c. Sonoma Water's Project-Activity Code X0158D038
 - d. Task performed with an itemized description of services rendered by date
 - e. Summary of work performed by subconsultants, as described in Paragraph 14.4
 - f. Time in quarter hours devoted to the task
 - g. Hourly rate or rates of the persons performing the task
 - h. List of reimbursable materials and expenses
 - i. Copies of receipts for reimbursable materials and expenses
- 4.4. *Monthly Reports with Invoices:* Payment of invoices is subject to receipt of the monthly reports required under Task 7 of Exhibit A.
- 4.5. *Cost Tracking:* Consultant has provided an estimated breakdown of costs, included in Exhibit C (Estimated Budget for Scope of Work). Exhibit C will only be used as a tool to monitor progress of work and budget. Actual payment will be made as specified in Paragraph 4.2 above.
- 4.6. *Timing of Payments:* Unless otherwise noted in this Agreement, payments shall be made within the normal course of Sonoma Water business after presentation of an invoice in a form approved by Sonoma Water for services performed. Payments shall be made only upon the satisfactory completion of the services as determined by Sonoma Water.

- 4.7. Taxes Withheld by Sonoma Water:
- a. Pursuant to California Revenue and Taxation Code (R&TC) section 18662, Sonoma Water shall withhold seven percent of the income paid to Consultant for services performed within the State of California under this Agreement, for payment and reporting to the California Franchise Tax Board, if Consultant does not qualify as: (1) a corporation with its principal place of business in California, (2) an LLC or Partnership with a permanent place of business in California, (3) a corporation/LLC or Partnership qualified to do business in California by the Secretary of State, or (4) an individual with a permanent residence in the State of California.
 - b. If Consultant does not qualify, as described in Paragraph 4.7.a, Sonoma Water requires that a completed and signed Form 587 be provided by Consultant in order for payments to be made. If Consultant is qualified, as described in Paragraph 4.7.a, then Sonoma Water requires a completed Form 590. Forms 587 and 590 remain valid for the duration of the Agreement provided there is no material change in facts. By signing either form, Consultant agrees to promptly notify Sonoma Water of any changes in the facts. Forms should be sent to Sonoma Water pursuant to Article 15 (Method and Place of Giving Notice, Submitting Bills, and Making Payments) of this Agreement. To reduce the amount withheld, Consultant has the option to provide Sonoma Water with either a full or partial waiver from the State of California.
- 4.8. *State or Grant Funding:* Consultant is informed and aware that this Agreement is funded by a grant from Department of Water Resources (award number 2015 Proposition 84 Integrated Regional Water Management Implementation Grant Agreement No. 4600011485), which grant is conditioned upon various terms that apply to Consultant. Consultant has reviewed the grant award documents attached hereto as Exhibit D and hereby agrees to comply with them to the extent they apply to a subrecipient. In the event of a conflict between the body of this Agreement and Exhibit D, the provisions in Exhibit D shall control.

5. **TERM OF AGREEMENT AND COMMENCEMENT OF WORK**

- 5.1. *Term of Agreement:* The term of this Agreement shall be from August 1, 2018, (“Effective Date”) to December 31, 2021, unless terminated earlier in accordance with the provisions of Article 6 (Termination).
- 5.2. *Commencement of Work:* Consultant is authorized to proceed immediately with the performance of this Agreement upon the Effective Date of this Agreement.

6. **TERMINATION**

- 6.1. *Authority to Terminate:* Sonoma Water's right to terminate may be exercised by Sonoma Water's General Manager.
- 6.2. *Termination Without Cause:* Notwithstanding any other provision of this Agreement, at any time and without cause, Sonoma Water shall have the right, in its sole discretion, to terminate this Agreement by giving 5 days written notice to Consultant.
- 6.3. *Termination for Cause:* Notwithstanding any other provision of this Agreement, should Consultant fail to perform any of its obligations hereunder, within the time and in the manner herein provided, or otherwise violate any of the terms of this Agreement, Sonoma Water may immediately terminate this Agreement by giving Consultant written notice of such termination, stating the reason for termination.
- 6.4. *Delivery of Work Product and Final Payment Upon Termination:* In the event of termination, Consultant, within 14 days following the date of termination, shall deliver to Sonoma Water all reports, original drawings, graphics, plans, studies, and other data or documents, in whatever form or format, assembled or prepared by Consultant or Consultant's subcontractors, consultants, and other agents in connection with this Agreement subject to Paragraph 12.10 and shall submit to Sonoma Water an invoice showing the services performed, hours worked, and copies of receipts for reimbursable expenses up to the date of termination.
- 6.5. *Payment Upon Termination:* Upon termination of this Agreement by Sonoma Water, Consultant shall be entitled to receive as full payment for all services satisfactorily rendered and reimbursable expenses properly incurred hereunder, an amount which bears the same ratio to the total payment specified in the Agreement as the services satisfactorily rendered hereunder by Consultant bear to the total services otherwise required to be performed for such total payment; provided, however, that if services are to be paid on a per-hour or per-day basis, then Consultant shall be entitled to receive as full payment an amount equal to the number of hours or days actually worked prior to termination multiplied by the applicable hourly or daily rate; and further provided, however, that if Sonoma Water terminates the Agreement for cause pursuant to Paragraph 6.3, Sonoma Water shall deduct from such amounts the amount of damage, if any, sustained by Sonoma Water by virtue of the breach of the Agreement by Consultant.
- 6.6. *Change in Funding:* Consultant understands and agrees that Sonoma Water shall have the right to terminate this Agreement immediately upon written notice to Consultant in the event that (1) any state or federal agency or other funder reduces, withholds or terminates funding which Sonoma Water anticipated using to pay Consultant for services provided under this Agreement or (2) Sonoma

Water has exhausted all funds legally available for payments due under this Agreement.

7. INDEMNIFICATION

7.1. Consultant agrees to accept all responsibility for loss or damage to any person or entity, including Sonoma County Water Agency and State of California, and to indemnify, hold harmless, and release Sonoma County Water Agency and State of California, their officers, agents, and employees, from and against any actions, claims, damages, liabilities, disabilities, or expenses, that may be asserted by any person or entity, including Consultant, that arise out of, pertain to, or relate to Consultant's or its agents', employees', contractors', subcontractors', or invitees' performance or obligations under this Agreement. Consultant agrees to provide a complete defense for any claim or action brought against Sonoma County Water Agency or State of California based upon a claim relating to Consultant's or its agents', employees', contractors', subcontractors', or invitees' performance or obligations under this Agreement. Consultant's obligations under this Article 7 apply whether or not there is concurrent or contributory negligence on the part of Sonoma County Water Agency or State of California, but, to the extent required by law, excluding liability due to conduct of Sonoma County Water Agency or State of California. Sonoma County Water Agency and State of California shall have the right to select their legal counsel at Consultant's expense, subject to Consultant's approval, which shall not be unreasonably withheld. This indemnification obligation is not limited in any way by any limitation on the amount or type of damages or compensation payable to or for Consultant or its agents under workers' compensation acts, disability benefits acts, or other employee benefit acts.

8. INSURANCE

8.1. With respect to performance of work under this Agreement, Consultant shall maintain and shall require all of its subcontractors, consultants, and other agents to maintain, insurance as described in Exhibit E (Insurance Requirements). Consultant affirms that it is aware of the provisions of section 3700 of the California Labor Code, which requires every employer to be insured against liability for workers' compensation or to undertake self-insurance in accordance with the provisions of that code, and Consultant affirms that it will comply with such provisions before commencing the performance of the work under this Agreement and will make its contractors and subcontractors aware of this provision.

9. PROSECUTION OF WORK

9.1. Performance of the services hereunder shall be completed within the time required herein, provided, however, that if the performance is delayed by earthquake, flood, high water, or other Act of God or by strike, lockout, or similar labor disturbances, the time for Consultant's performance of this Agreement

shall be extended by a number of days equal to the number of days Consultant has been delayed.

10. EXTRA OR CHANGED WORK

10.1. Extra or changed work or other changes to the Agreement may be authorized only by written amendment to this Agreement, signed by both parties. Changes to lengthen time schedules or make minor modifications to the scope of work, which do not increase the amount paid under the Agreement, may be executed by Sonoma Water's General Manager in a form approved by County Counsel. The parties expressly recognize that Sonoma Water personnel are without authorization to order all other extra or changed work or waive Agreement requirements. Failure of Consultant to secure such written authorization for extra or changed work shall constitute a waiver of any and all right to adjustment in the Agreement price or Agreement time due to such unauthorized work and thereafter Consultant shall be entitled to no compensation whatsoever for the performance of such work. Consultant further expressly waives any and all right or remedy by way of restitution and quantum meruit for any and all extra work performed without such express and prior written authorization of Sonoma Water.

11. CONTENT ONLINE ACCESSIBILITY

- 11.1. *Accessibility:* Sonoma Water policy requires that all documents that may be published to the Web meet accessibility standards to the greatest extent possible, and utilizing available existing technologies.
- 11.2. *Standards:* All consultants responsible for preparing content intended for use or publication on a Sonoma Water managed or Sonoma Water funded web site must comply with applicable federal accessibility standards established by 36 C.F.R. section 1194, pursuant to section 508 of the Rehabilitation Act of 1973, as amended (29 U.S.C. section 794(d)), and Sonoma Water's Web Site Accessibility Policy located at <http://sonomacounty.ca.gov/Services/Web-Standards-and-Guidelines/>.
- 11.3. *Certification:* With each final deliverable intended for public distribution (report, presentations posted to the Internet, public outreach materials), Consultant shall include a descriptive summary describing how all deliverable documents were assessed for accessibility (e.g., Microsoft Word accessibility check; Adobe Acrobat accessibility check, or other commonly accepted compliance check).
- 11.4. *Alternate Format:* When it is strictly impossible due to the unavailability of technologies required to produce an accessible document, Consultant shall identify the anticipated accessibility deficiency prior to commencement of any work to produce such deliverables. Consultant agrees to cooperate with Sonoma Water staff in the development of alternate document formats to

maximize the facilitative features of the impacted document(s); e.g., embedding the document with alt-tags that describe complex data/tables.

- 11.5. *Noncompliant Materials; Obligation to Cure:* Remediation of any materials that do not comply with Sonoma Water's Web Site Accessibility Policy shall be the responsibility of Consultant. If Sonoma Water, in its sole and absolute discretion, determines that any deliverable intended for use or publication on any Sonoma Water managed or Sonoma Water funded Web site does not comply with Sonoma Water Accessibility Standards, Sonoma Water will promptly inform Consultant in writing. Upon such notice, Consultant shall, without charge to Sonoma Water, repair or replace the non-compliant materials within such period of time as specified by Sonoma Water in writing. If the required repair or replacement is not completed within the time specified, Sonoma Water shall have the right to do any or all of the following, without prejudice to Sonoma Water's right to pursue any and all other remedies at law or in equity:
- a. Cancel any delivery or task order
 - b. Terminate this Agreement pursuant to the provisions of Article 6 (Termination); and/or
 - c. In the case of custom Electronic and Information Technology (EIT) developed by Consultant for Sonoma Water, Sonoma Water may have any necessary changes or repairs performed by itself or by another contractor. In such event, Consultant shall be liable for all expenses incurred by Sonoma Water in connection with such changes or repairs.
- 11.6. *Sonoma Water's Rights Reserved:* Notwithstanding the foregoing, Sonoma Water may accept deliverables that are not strictly compliant with Sonoma Water Accessibility Standards if Sonoma Water, in its sole and absolute discretion, determines that acceptance of such products or services is in Sonoma Water's best interest.

12. REPRESENTATIONS OF CONSULTANT

- 12.1. *Status of Consultant:* The parties intend that Consultant, in performing the services specified herein, shall act as an independent contractor and shall control the work and the manner in which it is performed. Consultant is not to be considered an agent or employee of Sonoma Water and is not entitled to participate in any pension plan, worker's compensation plan, insurance, bonus, or similar benefits Sonoma Water provides its employees. In the event Sonoma Water exercises its right to terminate this Agreement pursuant to Article 6 (Termination), Consultant expressly agrees that it shall have no recourse or right of appeal under rules, regulations, ordinances, or laws applicable to employees.
- 12.2. *No Suspension or Debarment:* Consultant warrants that it is not presently debarred, suspended, proposed for debarment, declared ineligible, or voluntarily excluded from participation in covered transactions by any federal department or agency. Consultant also warrants that it is not suspended or debarred from

receiving federal funds as listed in the List of Parties Excluded from Federal Procurement or Non-procurement Programs issued by the General Services Administration.

- 12.3. *Taxes:* Consultant agrees to file federal and state tax returns and pay all applicable taxes on amounts paid pursuant to this Agreement and shall be solely liable and responsible to pay such taxes and other obligations, including, but not limited to, state and federal income and FICA taxes. Consultant agrees to indemnify and hold Sonoma Water harmless from any liability which it may incur to the United States or to the State of California or to any other public entity as a consequence of Consultant's failure to pay, when due, all such taxes and obligations. In case Sonoma Water is audited for compliance regarding any withholding or other applicable taxes, Consultant agrees to furnish Sonoma Water with proof of payment of taxes on these earnings.
- 12.4. *Records Maintenance:* Consultant shall keep and maintain full and complete documentation and accounting records, in accordance with generally accepted accounting principles and practices, including, but not limited to, books, records, and other documents concerning all services performed that are compensable under this Agreement and shall make such documents and records available to Sonoma Water and the State of California for inspection at any reasonable time. Consultant shall maintain such records for a period of four (4) years following completion of work hereunder or final billing, whichever comes later.
- 12.5. *Conflict of Interest:* Consultant covenants that it presently has no interest and that it will not acquire any interest, direct or indirect, that represents a financial conflict of interest under state law or that would otherwise conflict in any manner or degree with the performance of its services hereunder. Consultant further covenants that in the performance of this Agreement no person having any such interests shall be employed. In addition, if required by law or requested to do so by Sonoma Water, Consultant shall submit a completed Fair Political Practices Commission Statement of Economic Interests (Form 700) with Sonoma Water within 30 calendar days after the Effective Date of this Agreement and each year thereafter during the term of this Agreement, or as required by state law.
- 12.6. *Statutory Compliance/Living Wage Ordinance:* Consultant agrees to comply, and to ensure compliance by its subconsultants or subcontractors, with all applicable federal, state and local laws, regulations, statutes and policies, including but not limited to the County of Sonoma Living Wage Ordinance, applicable to the services provided under this Agreement as they exist now and as they are changed, amended or modified during the term of this Agreement. Without limiting the generality of the foregoing, Consultant expressly acknowledges and agrees that this Agreement is subject to the provisions of Article XXVI of Chapter 2 of the Sonoma County Code, requiring payment of a living wage to covered employees. Noncompliance during the term of the Agreement will be

considered a material breach and may result in termination of the Agreement or pursuit of other legal or administrative remedies.

- 12.7. *Nondiscrimination*: During the performance of this Agreement, Consultant and its contractors or subcontractors shall not unlawfully discriminate, harass, or allow harassment against any employee or applicant for employment because of sex (gender), sexual orientation, race, color, ancestry, religion, creed, national origin (including language use restriction), pregnancy, physical disability (including HIV and AIDS), mental disability, medical condition (cancer/genetic characteristics), age (over 40), marital status, and denial of medial and family care leave or pregnancy disability leave. Consultant and its contractors or subcontractors shall ensure that the evaluation and treatment of their employees and applicants for employment are free from such discrimination and harassment. Consultant and its contractors or subcontractors shall comply with the provisions of the Fair Employment and Housing Act (California Government Code §12990 (a-f) et seq.) and the applicable regulations promulgated there under (California Code of Regulations, Title 2, §7285 et seq.). The applicable regulations of the Fair Employment and Housing Commission implementing California Government Code section 12990 (a-f), set forth in Chapter 5 of Division 4 of Title 2 of the California Code of Regulations, are incorporated into this Agreement by reference and made a part hereof as if set forth in full. Consultant and its contractors or subcontractors shall give written notice of their obligations under this clause to labor organizations with which they have a collective bargaining or other agreement.
- 12.8. *Drug-Free Workplace Certification (Certification of Compliance)*: By signing this Agreement, Consultant, its contractors or subcontractors hereby certify, under penalty of perjury under the laws of State of California, compliance with the requirements of the Drug-Free Workplace Act of 1990 (Government Code §8350 et seq.) and have or will provide a drug-free workplace by taking the following actions:
- a. Publish a statement notifying employees, contractors, and subcontractors that unlawful manufacture, distribution, dispensation, possession, or use of a controlled substance is prohibited and specifying actions to be taken against employees, contractors, or subcontractors for violations, as required by Government Code section 8355(a)(1).
 - b. Establish a Drug-Free Awareness Program, as required by Government Code section 8355(a)(2) to inform employees, contractors, or subcontractors about all of the following:
 - i. The dangers of drug abuse in the workplace,
 - ii. Consultant's policy of maintaining a drug-free workplace,
 - iii. Any available counseling, rehabilitation, and employee assistance programs, and

- iv. Penalties that may be imposed upon employees, contractors, and subcontractors for drug abuse violations.
 - c. Provide, as required by Government Code section 8355(a)(3), that every employee, contractor, and/or subcontractor who works under this Agreement:
 - i. Will receive a copy of Consultant's drug-free policy statement, and
 - ii. Will agree to abide by terms of Consultant's condition of employment, contract or subcontract.
- 12.9. *Assignment of Rights:* Consultant assigns to Sonoma Water all rights throughout the world in perpetuity in the nature of copyright, trademark, patent, right to ideas, in and to all versions of the plans and specifications, if any, now or later prepared by Consultant in connection with this Agreement. Consultant agrees to take such actions as are necessary to protect the rights assigned to Sonoma Water in this Agreement, and to refrain from taking any action which would impair those rights. Consultant's responsibilities under this provision include, but are not limited to, placing proper notice of copyright on all versions of the plans and specifications as Sonoma Water may direct, and refraining from disclosing any versions of the plans and specifications to any third party without first obtaining written permission of Sonoma Water. Consultant shall not use or permit another to use the plans and specifications in connection with this or any other project without first obtaining written permission of Sonoma Water.
- 12.10. *Ownership and Disclosure of Work Product:* All reports, original drawings, graphics, plans, studies, and other data or documents ("documents"), in whatever form or format, assembled or prepared by Consultant or Consultant's subcontractors, consultants, and other agents in connection with this Agreement shall be the property of Sonoma Water. Sonoma Water shall be entitled to immediate possession of such documents upon completion of the work pursuant to this Agreement. Upon expiration or termination of this Agreement, Consultant shall promptly deliver to Sonoma Water all such documents, which have not already been provided to Sonoma Water in such form or format as Sonoma Water deems appropriate. Such documents shall be and will remain the property of Sonoma Water without restriction or limitation. Consultant may retain copies of the above described documents but agrees not to disclose or discuss any information gathered, discovered, or generated in any way through this Agreement without the express written permission of Sonoma Water.

13. DEMAND FOR ASSURANCE

- 13.1. Each party to this Agreement undertakes the obligation that the other's expectation of receiving due performance will not be impaired. When reasonable grounds for insecurity arise with respect to the performance of either party, the other may in writing demand adequate assurance of due performance and until such assurance is received may, if commercially reasonable, suspend any performance for which the agreed return has not been received.

“Commercially reasonable” includes not only the conduct of a party with respect to performance under this Agreement, but also conduct with respect to other agreements with parties to this Agreement or others. After receipt of a justified demand, failure to provide within a reasonable time, but not exceeding thirty (30) days, such assurance of due performance as is adequate under the circumstances of the particular case is a repudiation of this Agreement. Acceptance of any improper delivery, service, or payment does not prejudice the aggrieved party's right to demand adequate assurance of future performance. Nothing in this Article 13 limits Sonoma Water's right to terminate this Agreement pursuant to Article 6 (Termination).

14. ASSIGNMENT AND DELEGATION

- 14.1. *Consent:* Neither party hereto shall assign, delegate, sublet, or transfer any interest in or duty under this Agreement without the prior written consent of the other, and no such transfer shall be of any force or effect whatsoever unless and until the other party shall have so consented.
- 14.2. *Subcontracts:* Notwithstanding the foregoing, Consultant may enter into subcontracts with the subconsultants specifically identified herein. If no subconsultants are listed, then no subconsultants will be utilized in the performance of the work specified in this Agreement.
- 14.3. *Change of Subcontractors or Subconsultants:* If, after execution of the Agreement, parties agree that subconsultants not listed in Paragraph 14.2 will be utilized, Consultant may enter into subcontracts with subconsultants to perform other specific duties pursuant to the provisions of this Paragraph 14.3. The following provisions apply to any subcontract entered into by Consultant other than those listed in Paragraph 14.2:
 - a. Prior to entering into any contract with subconsultant, Consultant shall obtain Sonoma Water approval of subconsultant.
 - b. All agreements with subconsultants shall (a) contain indemnity requirements in favor of Sonoma Water in substantially the same form as that contained in Article 7 (Indemnification), (b) contain language that the subconsultant may be terminated with or without cause upon reasonable written notice, and (c) prohibit the assignment or delegation of work under the agreement to any third party.
- 14.4. *Summary of Subconsultants' Work:* Consultant shall provide Sonoma Water with a summary of work performed by subconsultants with each invoice submitted under Paragraph 4.2.b. Such summary shall identify the individuals performing

work on behalf of subconsultants and the total amount paid to subconsultant, broken down by the tasks listed in the Scope of Work.

15. METHOD AND PLACE OF GIVING NOTICE, SUBMITTING BILLS, AND MAKING PAYMENTS

- 15.1. *Method of Delivery:* All notices, bills, and payments shall be made in writing and shall be given by personal delivery, U.S. Mail, courier service, or electronic means. Notices, bills, and payments shall be addressed as specified in Paragraph 3.2.
- 15.2. *Receipt:* When a notice, bill, or payment is given by a generally recognized overnight courier service, the notice, bill, or payment shall be deemed received on the next business day. When a copy of a notice, bill, or payment is sent by electronic means, the notice, bill, or payment shall be deemed received upon transmission as long as (1) the original copy of the notice, bill, or payment is deposited in the U.S. mail and postmarked on the date of the electronic transmission (for a payment, on or before the due date), (2) the sender has a written confirmation of the electronic transmission, and (3) the electronic transmission is transmitted before 5 p.m. (recipient's time). In all other instances, notices, bills, and payments shall be effective upon receipt by the recipient. Changes may be made in the names and addresses of the person to whom notices are to be given by giving notice pursuant to this Article 15.

16. MISCELLANEOUS PROVISIONS

- 16.1. *No Bottled Water:* In accordance with Sonoma Water Board of Directors Resolution No. 09-0920, dated September 29, 2009, no Sonoma Water funding shall be used to purchase single-serving, disposable water bottles for use in Sonoma Water facilities or at Sonoma Water-sponsored events. This restriction shall not apply when potable water is not available.
- 16.2. *No Waiver of Breach:* The waiver by Sonoma Water of any breach of any term or promise contained in this Agreement shall not be deemed to be a waiver of such term or promise or any subsequent breach of the same or any other term or promise contained in this Agreement.
- 16.3. *Construction:* To the fullest extent allowed by law, the provisions of this Agreement shall be construed and given effect in a manner that avoids any violation of statute, ordinance, regulation, or law. The parties covenant and agree that in the event that any provision of this Agreement is held by a court of competent jurisdiction to be invalid, void, or unenforceable, the remainder of the provisions hereof shall remain in full force and effect and shall in no way be affected, impaired, or invalidated thereby. Consultant and Sonoma Water acknowledge that they have each contributed to the making of this Agreement and that, in the event of a dispute over the interpretation of this Agreement, the language of the Agreement will not be construed against one party in favor of

the other. Consultant and Sonoma Water acknowledge that they have each had an adequate opportunity to consult with counsel in the negotiation and preparation of this Agreement.

- 16.4. *Consent:* Wherever in this Agreement the consent or approval of one party is required to an act of the other party, such consent or approval shall not be unreasonably withheld or delayed.
- 16.5. *No Third-Party Beneficiaries:* Except as provided in Article 7 (Indemnification), nothing contained in this Agreement shall be construed to create and the parties do not intend to create any rights in third parties.
- 16.6. *Applicable Law and Forum:* This Agreement shall be construed and interpreted according to the substantive law of California, regardless of the law of conflicts to the contrary in any jurisdiction. Any action to enforce the terms of this Agreement or for the breach thereof shall be brought and tried in Santa Rosa or in the forum nearest to the City of Santa Rosa, in the County of Sonoma.
- 16.7. *Captions:* The captions in this Agreement are solely for convenience of reference. They are not a part of this Agreement and shall have no effect on its construction or interpretation.
- 16.8. *Merger:* This writing is intended both as the final expression of the Agreement between the parties hereto with respect to the included terms and as a complete and exclusive statement of the terms of the Agreement, pursuant to Code of Civil Procedure section 1856. Each Party acknowledges that, in entering into this Agreement, it has not relied on any representation or undertaking, whether oral or in writing, other than those which are expressly set forth in this Agreement. No modification of this Agreement shall be effective unless and until such modification is evidenced by a writing signed by both parties.
- 16.9. *Survival of Terms:* All express representations, waivers, indemnifications, and limitations of liability included in this Agreement will survive its completion or termination for any reason.
- 16.10. *Time of Essence:* Time is and shall be of the essence of this Agreement and every provision hereof.

/

/

/

/

/

/

/

IN WITNESS WHEREOF, the parties hereto have executed this Agreement as of the date last signed by the parties to the Agreement.

Reviewed as to funds:

TW 18/19-003

By: _____
Sonoma Water Division Manager -
Administrative Services

Approved as to form:

By: _____
Adam Brand, Deputy County Counsel

Insurance Documentation is on file with
Sonoma Water

Date/TW Initials: 8/28/18 crt

Sonoma County Water Agency

Bay Planning Coalition, a California
corporation

By: _____
Grant Davis
General Manager
Authorized per Sonoma Water's Board
of Directors Action on November 13,
2018

By: _____

(Please print name here)

Title: _____

Date: _____

Date: _____

Exhibit A

Scope of Work

1. TASKS

1.1. Task 1: AQPI Project Management Team Meetings

- a. Participate in monthly AQPI Project Management Team calls on the third Friday of each month at 10 am.

Deliverable	Due Date
Included in Task 6	See Task 6

1.2. Task 2: Stakeholder Outreach

- a. In consultation with Sonoma Water and Jennifer Krebs dba Jennifer Krebs Environmental Planning (JKEP), identify stakeholder needs assessment, identify key stakeholder traits, and define stakeholder list parameters.
- b. In consultation with JKEP, develop a key stakeholders list including key personnel name, phone, email, mailing address, organization name, title, and potential interest in AQPI.
 - i. First Draft: Prepare the list in draft form and submit to Sonoma Water for review and approval in accordance with the date listed for this deliverable. Sonoma Water will return one copy to Consultant with comments or approval in writing.
 - ii. Subsequent Draft(s): If Sonoma Water requests revisions, revise the draft list and resubmit one copy for Sonoma Water approval.
 - iii. Final: Following Sonoma Water approval and prior to Sonoma Water's acceptance of work under this Agreement, submit the final approved list to Sonoma Water in accordance with the date listed for this deliverable.
- c. Set-up introductory individual meetings with key stakeholders and Sonoma Water and prepare meeting minutes.

Deliverable	Due Date
Draft Key Stakeholders List	Within 45 calendar days of Effective Date
Final Key Stakeholders List	Within 15 calendar days of Sonoma Water approval of draft
Introductory Meetings	Within 60 calendar days of Sonoma Water approval of final list
Meeting Minutes	Include with Monthly Progress Reports under Task 6

1.3. Task 3: Stakeholder Advisory Committee

- a. In consultation with Sonoma Water and JKEP, as needed:
 - i. Define and develop advisory committee role, function, size, governance, and goals.
 - ii. Generate a potential list of members based on stakeholder outreach meetings.
 - iii. Develop a work plan and timeline for the committee.
 - iv. Develop an end-user needs assessment in coordination with AQPI Project Management Team.
 - v. Invite stakeholders to participate in an advisory committee meeting.
 - vi. Schedule and host advisory meetings with AQPI Project Management Team as needed.
 - vii. Schedule four committee meetings per year, or as needed, per AQPI Project Management Team request.

Deliverable	Due Date
Draft Work Plan	To be determined
Final Work Plan	To be determined
Draft end-user needs assessment	To be determined
Final end-user needs assessment	To be determined

1.4. Task 4: Stakeholder Outreach and Communications

- a. Work with Sonoma Water to develop an AQPI stakeholder, public facing website that includes meeting agendas, notes, PowerPoints, and general project update content development.
 - i. First Draft: Prepare the content in draft form and submit to Sonoma Water for review and approval in accordance with the date listed for this deliverable. Sonoma Water will return one copy Consultant with comments or approval in writing.
 - ii. Subsequent Draft(s): If Sonoma Water requests revisions, revise the draft content and resubmit one copy for Sonoma Water approval.
 - iii. Final: Following Sonoma Water approval and prior to Sonoma Water’s acceptance of work under this Agreement, submit the final approved content to Sonoma Water in accordance with the date listed for this deliverable.
- b. Keep content updated for stakeholder outreach purposes
- c. Develop and maintain quarterly electronic newsletter for stakeholder outreach purposes, including database management of contact information
 - i. First Draft: Prepare the newsletter in draft form and submit to Sonoma Water for review and approval in accordance with the date listed for this deliverable. Sonoma Water will return one copy Consultant with comments or approval in writing.

- ii. Subsequent Draft(s): If Sonoma Water requests revisions, revise the draft newsletter and resubmit one copy for Sonoma Water approval.
- iii. Final: Following Sonoma Water approval and prior to Sonoma Water’s acceptance of work under this Agreement, submit the final approved newsletter to Sonoma Water in accordance with the date listed for this deliverable.

Deliverable	Due Date
Draft Website Content	Within 45 calendar days of Effective Date
Final Website Content	Within 10 calendar days of Sonoma Water approval of draft
Draft Newsletter	Within 90 calendar days of Effective Date and quarterly thereafter
Final Newsletter	Within 10 calendar days of Sonoma Water approval of draft

1.5. Task 5: Monitoring

- a. Monitor ongoing Bay Area trends and issues related to AQPI

Deliverable	Due Date
Included in Task 6	See Task 6

1.6. Task 6: Monthly Progress Reports

- a. Prepare monthly progress reports. Submit one copy to Sonoma Water in accordance with the date listed for this deliverable.
- b. Include the following in each monthly progress:
 - i. A detailed list of work performed
 - ii. Dates and subject of meetings conducted, meeting attendees, and summary of meeting results
 - iii. Other information as appropriate or as requested by Sonoma Water

Deliverable	Due Date
Monthly Progress Report	Monthly with invoices

1.7. Optional Task 7: Additional Services

- a. Do not proceed with this task unless requested in writing by Sonoma Water.
- b. Perform additional services as requested by Sonoma Water to support the stakeholder outreach coordination effort. The additional services will be agreed to by Consultant and Sonoma Water and described in writing by Sonoma Water.

2. DELIVERABLES

- 2.1. Submit one electronic copy in PDF format (emailed, on CD, or via internet) of each final deliverable to Sonoma Water.
- 2.2. Comply with requirements of Article 11 (Content Online Accessibility).

Exhibit B

Schedule of Costs

PERSONNEL	
Title	Hourly Rate
John A. Coleman, Chief Executive Officer	\$140
Ann Spaulding, Program Manager	\$150
Brianne Riley, Manager, Operations and Policy	\$75
Roman Berenshteyn, Senior Policy Associate	\$75
Aidan Offermann, Program Assistant	\$45
EXPENSES	
Item	Cost
Legal Fees	at cost
In-house copies	\$0.10 per page
Outside printing	at cost
Postage	at cost
Overnight mail	at cost
Software license	at cost
Travel Expenses:	
<ul style="list-style-type: none"> • Rental car, daily rate • Meals and lodging • Consultant’s airfare for attending workshops, conferences, and meetings as necessary and requested by Sonoma Water’s Project Manager 	<ul style="list-style-type: none"> • at cost • at cost • at cost, not to exceed \$350 per trip

Exhibit C

Estimated Budget for Scope of Work

Task	Chief Executive Officer	Program Manager	Manager, Operations and Policy	Senior Policy Associate	Program Assistant	Total
1. Project Management/Meetings	\$8,764	\$39,000	\$2,925	\$ 2,388.75	\$2,923	\$56,001
2. Stakeholder Outreach	\$10,955	\$48,750	\$3,656	\$ -	\$0	\$63,362
3. Stakeholder Advisory Committee	\$6,573	\$48,750	\$2,194	\$ -	\$0	\$57,517
4. Stakeholder Outreach and Communications	\$8,764	\$48,750	\$2,925	\$ 341.25	\$15,588	\$76,370
5. Monitoring	\$6,573	\$5,850	\$2,194	\$ 2,730.00	\$0	\$17,347
6. Monthly Progress Reports	\$2,191	\$3,900	\$731	\$ 1,365.00	\$974	\$9,162
7. Additional Services	TBD	TBD	TBD	TBD	TBD	\$10,000
Expenses						\$ 10,241.00
Total	\$ 43,820.00	\$ 195,000.00	\$ 14,625.00	\$ 6,825.00	\$ 19,485.00	\$300,000

Exhibit D

Grant Award Documents

Grant Agreement No. 4600011485
Page 19 of 35

EXHIBIT D STANDARD CONDITIONS

D.1) **ACCOUNTING AND DEPOSIT OF FUNDING DISBURSEMENT:**

- a) Separate Accounting of Funding Disbursements and Interest Records: Grantee shall account for the money disbursed pursuant to this Grant Agreement separately from all other Grantee funds. Grantee shall maintain audit and accounting procedures that are in accordance with generally accepted accounting principles and practices, consistently applied. Grantee shall keep complete and accurate records of all receipts, disbursements, and interest earned on expenditures of such funds. Grantee shall require its contractors or subcontractors to maintain books, records, and other documents pertinent to their work in accordance with generally accepted accounting principles and practices. Records are subject to inspection by State at any and all reasonable times.
- b) Fiscal Management Systems and Accounting Standards: The Grantee agrees that, at a minimum, its fiscal control and accounting procedures will be sufficient to permit tracing of grant funds to a level of expenditure adequate to establish that such funds have not been used in violation of state law or this Grant Agreement.
- c) Disposition of Money Disbursed: All money disbursed pursuant to this Grant Agreement shall be deposited, administered, and accounted for pursuant to the provisions of applicable law.
- d) Remittance of Unexpended Funds: Grantee shall remit to State any unexpended funds that were disbursed to Grantee under this Grant Agreement and were not used to pay Eligible Project Costs within a period of sixty (60) calendar days from the final disbursement from State to Grantee of funds or, within thirty (30) calendar days of the expiration of the Grant Agreement, whichever comes first.

D.2) **ACKNOWLEDGEMENT OF CREDIT:** Grantee shall include appropriate acknowledgement of credit to the State and to all cost-sharing partners for their support when promoting the Project or using any data and/or information developed under this Grant Agreement. During construction of the project, Grantee shall install a sign at a prominent location, which shall include a statement that the project is financed under the Safe Drinking Water, Water Quality and Supply, Flood Control, River and Coastal Protection Bond Act of 2006, administered by State of California, Department of Water Resources. Grantee shall notify State that the sign has been erected by providing them with a site map with the sign location noted and a photograph of the sign.

D.3) **AIR OR WATER POLLUTION VIOLATION:** Under State laws, the Grantee shall not be: (1) in violation of any order or resolution not subject to review promulgated by the State Air Resources Board or an air pollution control district; (2) subject to cease and desist order not subject to review issued pursuant to §13301 of the Water Code for violation of waste discharge requirements or discharge prohibitions; or (3) finally determined to be in violation of provisions of federal law relating to air or water pollution.

D.4) **AMENDMENT:** This Grant Agreement may be amended at any time by mutual agreement of the Parties, except insofar as any proposed amendments are in any way contrary to applicable law. Requests by the Grantee for amendments must be in writing stating the amendment request and the reason for the request. State shall have no obligation to agree to an amendment.

D.5) **AMERICANS WITH DISABILITIES ACT:** By signing this Grant Agreement, Grantee assures State that it complies with the Americans with Disabilities Act (ADA) of 1990, (42 U.S.C., 12101 et seq.), which prohibits discrimination on the basis of disability, as well as all applicable regulations and guidelines issued pursuant to the ADA.

D.6) **APPROVAL:** This Agreement is of no force or effect until signed by all parties to the agreement. Grantee may not submit invoices or receive payment until all required signatures have been obtained.

D.7) **AUDITS:** State reserves the right to conduct an audit at any time between the execution of this Grant Agreement and the completion of the Project, with the costs of such audit borne by State. After completion of the Project, State may require Grantee to conduct a final audit to State's specifications, at Grantee's expense, such audit to be conducted by and a report prepared by an independent

Certified Public Accountant. Failure or refusal by Grantee to comply with this provision shall be considered a breach of this Grant Agreement, and State may elect to pursue any remedies provided in Paragraph 14 or take any other action it deems necessary to protect its interests.

Pursuant to Government Code §8546.7, the Grantee shall be subject to the examination and audit by the State for a period of three years after final payment under this Grant Agreement with respect to all matters connected with this Grant Agreement, including but not limited to, the cost of administering this Grant Agreement. All records of Grantee or its contractor or subcontractors shall be preserved for this purpose for at least three (3) years after project completion or final billing, whichever comes later.

- D.8) BUDGET CONTINGENCY:** If the Budget Act of the current year covered under this Grant Agreement does not appropriate sufficient funds for the Proposition 84 Implementation Grant Program, this Grant Agreement shall be of no force and effect. This provision shall be construed as a condition precedent to the obligation of State to make any payments under this Grant Agreement. In this event, State shall have no liability to pay any funds whatsoever to Grantee or to furnish any other considerations under this Grant Agreement and Grantee shall not be obligated to perform any provisions of this Grant Agreement. Nothing in this Grant Agreement shall be construed to provide Grantee with a right of priority for payment over any other Grantee. If funding for any fiscal year after the current year covered by this Grant Agreement is reduced or deleted by the Budget Act for purposes of this program, State shall have the option to either cancel this Grant Agreement with no liability occurring to State, or offer a Grant Agreement amendment to Grantee to reflect the reduced amount.
- D.9) CALIFORNIA CONSERVATION CORPS:** As required in Water Code §79038(b), Grantee shall examine the feasibility of using the California Conservation Corps or community conservation corps to accomplish the habitat restoration, enhancement and protection activities listed in the Exhibit A, Work Plan, and shall use the services of one of these organizations whenever feasible.
- D.10) CEQA:** Activities funded under this Grant Agreement, regardless of funding source, must be in compliance with the California Environmental Quality Act (CEQA) (Public Resources Code §21000 et seq.). Information on CEQA may be found at the following links:
Environmental Information: <http://resources.ca.gov/ceqa/>
California State Clearinghouse Handbook:
https://www.opr.ca.gov/docs/SCH_Handbook_2012.pdf
- D.11) CHILD SUPPORT COMPLIANCE ACT:** For any Grant Agreement in excess of \$100,000, the Grantee acknowledges in accordance with Public Contract Code §7110, that:
- a) The Grantee recognizes the importance of child and family support obligations and shall fully comply with all applicable state and federal laws relating to child and family support enforcement, including, but not limited to, disclosure of information and compliance with earnings assignment orders, as provided in Chapter 8 (commencing with §5200) of Part 5 of Division 9 of the Family Code; and
 - b) The Grantee, to the best of its knowledge is fully complying with the earnings assignment orders of all employees and is providing the names of all new employees to the New Hire Registry maintained by the California Employment Development Department.
- D.12) CLAIMS DISPUTE:** Any claim that the Grantee may have regarding performance of this agreement including, but not limited to, claims for additional compensation or extension of time, shall be submitted to the State's Project Manager, within thirty (30) calendar days of the Grantee's knowledge of the claim. State and Grantee shall then attempt to negotiate a resolution of such claim and process an amendment to this Agreement to implement the terms of any such resolution.
- D.13) COMPETITIVE BIDDING AND PROCUREMENTS:** Grantee shall comply with all applicable laws and regulations regarding securing competitive bids and undertaking competitive negotiations in Grantee's contracts with other entities for acquisition of goods and services and construction of public works with funds provided by State under this Grant Agreement.

- D.14) COMPUTER SOFTWARE:** Grantee certifies that it has appropriate systems and controls in place to ensure that state funds will not be used in the performance of this Grant Agreement for the acquisition, operation, or maintenance of computer software in violation of copyright laws.
- D.15) CONFLICT OF INTEREST:** All participants are subject to State and Federal conflict of interest laws. Failure to comply with these laws, including business and financial disclosure provisions, will result in the application being rejected and any subsequent contract being declared void. Other legal action may also be taken. Applicable statutes include, but are not limited to, Government Code, § 1090 and Public Contract Code, § 10410 and § 10411, for State conflict of interest requirements.
- a) **Current State Employees:** No State officer or employee shall engage in any employment, activity, or enterprise from which the officer or employee receives compensation or has a financial interest and which is sponsored or funded by any State agency, unless the employment, activity, or enterprise is required as a condition of regular State employment. No State officer or employee shall contract on his or her own behalf as an independent contractor with any State agency to provide goods or services.
 - b) **Former State Employees:** For the two-year period from the date he or she left State employment, no former State officer or employee may enter into a contract in which he or she engaged in any of the negotiations, transactions, planning, arrangements, or any part of the decision-making process relevant to the contract while employed in any capacity by any State agency. For the twelve-month period from the date he or she left State employment, no former State officer or employee may enter into a contract with any State agency if he or she was employed by that State agency in a policy-making position in the same general subject area as the proposed contract within the twelve-month period prior to his or her leaving State service.
 - c) **Employees of the Grantee:** Employees of the Grantee shall comply with all applicable provisions of law pertaining to conflicts of interest, including but not limited to any applicable conflict of interest provisions of the California Political Reform Act, Government Code § 87100 *et seq.*
 - d) **Employees and Consultants to the Grantee:** Individuals working on behalf of a Grantee may be required by the Department to file a Statement of Economic Interests (Fair Political Practices Commission Form 700) if it is determined that an individual is a consultant for Political Reform Act purposes.
- D.16) DELIVERY OF INFORMATION, REPORTS, AND DATA:** Grantee agrees to expeditiously provide throughout the term of this Grant Agreement, such reports, data, information, and certifications as may be reasonably required by State.
- D.17) DISPOSITION OF EQUIPMENT:** Grantee shall provide to State, not less than 30 calendar days prior to submission of the final invoice, an itemized inventory of equipment purchased with funds provided by State. The inventory shall include all items with a current estimated fair market value of more than \$5,000.00 per item. Within 60 calendar days of receipt of such inventory State shall provide Grantee with a list of the items on the inventory that State will take title to. All other items shall become the property of Grantee. State shall arrange for delivery from Grantee of items that it takes title to. Cost of transportation, if any, shall be borne by State.
- D.18) DRUG-FREE WORKPLACE CERTIFICATION:** Certification of Compliance: By signing this Grant Agreement, Grantee, its contractors or subcontractors hereby certify, under penalty of perjury under the laws of State of California, compliance with the requirements of the Drug-Free Workplace Act of 1990 (Government Code § 8350 *et seq.*) and have or will provide a drug-free workplace by taking the following actions:
- a) Publish a statement notifying employees, contractors, and subcontractors that unlawful manufacture, distribution, dispensation, possession, or use of a controlled substance is prohibited and specifying actions to be taken against employees, contractors, or subcontractors for violations, as required by Government Code § 8355(a)(1).

- b) Establish a Drug-Free Awareness Program, as required by Government Code §8355(a)(2) to inform employees, contractors, or subcontractors about all of the following:
 - i) The dangers of drug abuse in the workplace,
 - ii) Grantee's policy of maintaining a drug-free workplace,
 - iii) Any available counseling, rehabilitation, and employee assistance programs, and
 - iv) Penalties that may be imposed upon employees, contractors, and subcontractors for drug abuse violations.
 - c) Provide, as required by Government Code §8355(a)(3), that every employee, contractor, and/or subcontractor who works under this Grant Agreement:
 - i) Will receive a copy of Grantee's drug-free policy statement, and
 - ii) Will agree to abide by terms of Grantee's condition of employment, contract or subcontract.
- D.19) FINAL INSPECTIONS AND CERTIFICATION OF REGISTERED PROFESSIONAL:** Upon completion of the Project, Grantee shall provide for a final inspection and certification by the appropriate registered professional (California Registered Civil Engineer or Geologist) that the Project has been completed in accordance with submitted final plans and specifications and any modifications thereto and in accordance with this Grant Agreement. Grantee shall notify the State's Project Manager of the inspection date at least 14 calendar days prior to the inspection in order to provide State the opportunity to participate in the inspection.
- D.20) GRANTEE COMMITMENTS:** Grantee accepts and agrees to comply with all terms, provisions, conditions and commitments of this Grant Agreement, including all incorporated documents, and to fulfill all assurances, declarations, representations, and statements made by the Grantee in the application, documents, amendments, and communications filed in support of its request for funding.
- D.21) GRANTEE NAME CHANGE:** Approval of the State's Program Manager is required to change the Grantee's name as listed on this Grant Agreement. Upon receipt of legal documentation of the name change the State will process an amendment. Payment of invoices presented with a new name cannot be paid prior to approval of said amendment.
- D.22) GOVERNING LAW:** This Grant Agreement is governed by and shall be interpreted in accordance with the laws of the State of California.
- D.23) INDEMNIFICATION:** Grantee shall indemnify and hold and save the State, its officers, agents, and employees, free and harmless from any and all liabilities for any claims and damages (including inverse condemnation) that may arise out of the Project and this Agreement, including, but not limited to any claims or damages arising from planning, design, construction, maintenance and/or operation of levee rehabilitation measures for this Project and any breach of this Agreement. Grantee shall require its contractors or subcontractors to name the State, its officers, agents and employees as additional insured on their liability insurance for activities undertaken pursuant to this Agreement.
- D.24) INDEPENDENT CAPACITY:** Grantee, and the agents and employees of Grantees, in the performance of the Grant Agreement, shall act in an independent capacity and not as officers, employees, or agents of the State.
- D.25) INSPECTION OF BOOKS, RECORDS, AND REPORTS:** During regular office hours, each of the parties hereto and their duly authorized representatives shall have the right to inspect and to make copies of any books, records, or reports of either party pertaining to this Grant Agreement or matters related hereto. Each of the parties hereto shall maintain and shall make available at all times for such inspection accurate records of all its costs, disbursements, and receipts with respect to its activities under this Grant Agreement. Failure or refusal by Grantee to comply with this provision shall be considered a breach of this Grant Agreement, and State may withhold disbursements to Grantee or take any other action it deems necessary to protect its interests.
- D.26) INSPECTIONS OF PROJECT BY STATE:** State shall have the right to inspect the work being performed at any and all reasonable times during the term of the Grant Agreement. This right shall extend to any subcontracts, and Grantee shall include provisions ensuring such access in all its contracts or subcontracts entered into pursuant to its Grant Agreement with State.

- D.27) INVOICE DISPUTES:** In the event of an invoice dispute, payment will not be made until the dispute is resolved and a corrected invoice submitted. Failure to use the address exactly as provided may result in return of the invoice to the Grantee. Payment shall be deemed complete upon deposit of the payment, properly addressed, postage prepaid, in the United States mail. Any claim that Grantee may have regarding the performance of this Grant Agreement including, but not limited to claims for additional compensation or extension of time, shall be submitted to the DWR Project Manager within thirty (30) calendar days of Grantee's knowledge of the claim. State and Grantee shall then attempt to negotiate a resolution of such claim and process an amendment to the Grant Agreement to implement the terms of any such resolution.
- D.28) LABOR CODE COMPLIANCE:** The Grantee will be required to keep informed of and take all measures necessary to ensure compliance with applicable Labor Code requirements, including, but not limited to, §1720 *et seq.* of the Labor Code regarding public works, limitations on use of volunteer labor (Labor Code §1720.4), labor compliance programs (Labor Code §1771.5) and payment of prevailing wages for work done and funded pursuant to these Guidelines, including any payments to the Department of Industrial Relations under Labor Code §1771.3.
- D.29) NONDISCRIMINATION:** During the performance of this Grant Agreement, Grantee and its contractors or subcontractors shall not unlawfully discriminate, harass, or allow harassment against any employee or applicant for employment because of sex (gender), sexual orientation, race, color, ancestry, religion, creed, national origin (including language use restriction), pregnancy, physical disability (including HIV and AIDS), mental disability, medical condition (cancer/genetic characteristics), age (over 40), marital status, and denial of medical and family care leave or pregnancy disability leave. Grantee and its contractors or subcontractors shall ensure that the evaluation and treatment of their employees and applicants for employment are free from such discrimination and harassment. Grantee and its contractors or subcontractors shall comply with the provisions of the Fair Employment and Housing Act (Government Code §12990 (a-f) *et seq.*) and the applicable regulations promulgated there under (California Code of Regulations, Title 2, §7285 *et seq.*). The applicable regulations of the Fair Employment and Housing Commission implementing Government Code §12990 (a-f), set forth in Chapter 5 of Division 4 of Title 2 of the California Code of Regulations, are incorporated into this Agreement by reference and made a part hereof as if set forth in full. Grantee and its contractors or subcontractors shall give written notice of their obligations under this clause to labor organizations with which they have a collective bargaining or other agreement.
- Grantee shall include the nondiscrimination and compliance provisions of this clause in all subcontracts to perform work under the Grant Agreement.
- D.30) NO DISCRIMINATION AGAINST DOMESTIC PARTNERS:** For contracts over \$100,000 executed or amended after January 1, 2007, the Grantee certifies by signing this Grant Agreement, under penalty of perjury under the laws of State of California that Grantee is in compliance with Public Contract Code §10295.3.
- D.31) OPINIONS AND DETERMINATIONS:** Where the terms of this Grant Agreement provide for action to be based upon, judgment, approval, review, or determination of either party hereto, such terms are not intended to be and shall never be construed as permitting such opinion, judgment, approval, review, or determination to be arbitrary, capricious, or unreasonable.
- D.32) PERFORMANCE AND ASSURANCES:** Grantee agrees to faithfully and expeditiously perform or cause to be performed all Project work as described in Exhibit A (Work Plan) and to apply State funds received only to Eligible Project Costs in accordance with applicable provisions of the law.
- D.33) PRIORITY HIRING CONSIDERATIONS:** If this Grant Agreement includes services in excess of \$200,000, the Grantee shall give priority consideration in filling vacancies in positions funded by the Grant Agreement to qualified recipients of aid under Welfare and Institutions Code §11200 in accordance with Public Contract Code §10353.
- D.34) PROHIBITION AGAINST DISPOSAL OF PROJECT WITHOUT STATE PERMISSION:** The Grantee shall not sell, abandon, lease, transfer, exchange, mortgage, hypothecate, or encumber in any manner whatsoever all or any portion of any real or other property necessarily connected or used in conjunction with the

Project, or with Grantee's service of water, without prior permission of State. Grantee shall not take any action, including but not limited to actions relating to user fees, charges, and assessments that could adversely affect the ability of Grantee to meet its obligations under this Grant Agreement, without prior written permission of State. State may require that the proceeds from the disposition of any real or personal property be remitted to State.

- D.35) REMEDIES NOT EXCLUSIVE:** The use by either party of any remedy specified herein for the enforcement of this Grant Agreement is not exclusive and shall not deprive the party using such remedy of, or limit the application of, any other remedy provided by law.
- D.36) RETENTION:** Notwithstanding any other provision of this Grant Agreement, State shall, for each project, withhold five percent (5.0%) until January 1, 2018 and ten percent (10.0%), thereafter, of the funds requested by Grantee for reimbursement of Eligible Costs. Each project in this Grant Agreement will be eligible to release its respective retention when that project is completed and Grantee has met requirements of Paragraph 19, "Submissions of Reports", except in the case of the last project to be completed under this Grant Agreement, in which case retention for such project will not be disbursed until the "Grant Completion Report" is submitted to and approved by State. State shall disburse retained funds to the Grantee.
- D.37) RIGHTS IN DATA:** Grantee agrees that all data, plans, drawings, specifications, reports, computer programs, operating manuals, notes and other written or graphic work produced in the performance of this Grant Agreement shall be made available to the State and shall be in the public domain to the extent to which release of such materials is required under the California Public Records Act., Government Code §6250 *et seq.* Grantee may disclose, disseminate and use in whole or in part, any final form data and information received, collected and developed under this Grant Agreement, subject to appropriate acknowledgement of credit to State for financial support. Grantee shall not utilize the materials for any profit-making venture or sell or grant rights to a third party who intends to do so. The State shall have the right to use any data described in this paragraph for any public purpose.
- D.38) SEVERABILITY:** Should any portion of this Grant Agreement be determined to be void or unenforceable, such shall be severed from the whole and the Grant Agreement shall continue as modified.
- D.39) STATE REVIEWS:** The parties agree that review or approval of the project application, documents, permits, plans, and specifications or other project information by the State is for administrative purposes only and does not relieve the Grantee of their responsibility to properly plan, design, construct, operate, maintain, implement, or otherwise carry out the project.
- D.40) SUSPENSION OF PAYMENTS:** This Grant Agreement may be subject to suspension of payments or termination, or both, and Grantee may be subject to debarment if the State determines that:
- a) Grantee, its contractors, or subcontractors have made a false certification, or
 - b) Grantee, its contractors, or subcontractors violates the certification by failing to carry out the requirements noted in this Grant Agreement.
- D.41) SUCCESSORS AND ASSIGNS:** This Grant Agreement and all of its provisions shall apply to and bind the successors and assigns of the parties. No assignment or transfer of this Grant Agreement or any part thereof, rights hereunder, or interest herein by the Grantee shall be valid unless and until it is approved by State and made subject to such reasonable terms and conditions as State may impose.
- D.42) TERMINATION BY GRANTEE:** Subject to State approval which may be reasonably withheld, Grantee may terminate this Agreement and be relieved of contractual obligations. In doing so, Grantee must provide a reason(s) for termination. Grantee must submit all progress reports summarizing accomplishments up until termination date.
- D.43) TERMINATION FOR CAUSE:** Subject to the right to cure under Paragraph 14, the State may terminate this Grant Agreement and be relieved of any payments should Grantee fail to perform the requirements of this Grant Agreement at the time and in the manner herein, provided including but not limited to reasons of default under Paragraph 14.

- D.44) TERMINATION WITHOUT CAUSE:** The State may terminate this Grant Agreement without cause on 30 calendar days advance written notice. The Grantee shall be reimbursed for all reasonable expenses incurred up to the date of termination.
- D.45) THIRD PARTY BENEFICIARIES:** The parties to this Grant Agreement do not intend to create rights in, or grant remedies to, any third party as a beneficiary of this Agreement, or any duty, covenant, obligation or understanding established herein.
- D.46) TIMELINESS:** Time is of the essence in this Grant Agreement.
- D.47) TRAVEL:** Grantee agrees that travel and per diem costs shall NOT be eligible for reimbursement with State funds, and shall NOT be eligible for computing Grantee cost match. Travel includes the costs of transportation, subsistence, and other associated costs incurred by personnel during the term of this Grant Agreement.
- D.48) WAIVER OF RIGHTS:** None of the provisions of this Grant Agreement shall be deemed waived unless expressly waived in writing. It is the intention of the parties here to that from time to time either party may waive any of its rights under this Grant Agreement unless contrary to law. Any waiver by either party of rights arising in connection with the Grant Agreement shall not be deemed to be a waiver with respect to any other rights or matters, and such provisions shall continue in full force and effect.
- D.49) WORKERS' COMPENSATION:** Grantee affirms that it is aware of the provisions of §3700 of the Labor Code, which requires every employer to be insured against liability for workers' compensation or to undertake self-insurance in accordance with the provisions of that code, and Grantee affirms that it will comply with such provisions before commencing the performance of the work under this Grant Agreement and will make its contractors and subcontractors aware of this provision.

Exhibit E

Insurance Requirements

With respect to performance of work under this Agreement, Consultant shall maintain and shall require all of its subcontractors, consultants, and other agents to maintain insurance as described below unless such insurance has been expressly waived by the attachment of a *Waiver of Insurance Requirements*. Any requirement for insurance to be maintained after completion of the work shall survive this Agreement.

Sonoma Water reserves the right to review any and all of the required insurance policies and/or endorsements, but has no obligation to do so. Failure to demand evidence of full compliance with the insurance requirements set forth in this Agreement or failure to identify any insurance deficiency shall not relieve Consultant from, nor be construed or deemed a waiver of, its obligation to maintain the required insurance at all times during the performance of this Agreement.

1. **INSURANCE**

1.1. Workers Compensation and Employers Liability Insurance

- a. Required if Consultant has employees as defined by the Labor Code of the State of California.
- b. If Consultant currently has no employees as defined by the Labor Code of the State of California, Consultant agrees to obtain the above-specified Workers Compensation and Employers' Liability insurance should employees be engaged during the term of this Agreement or any extensions of the term.

1.2. General Liability Insurance

- a. Commercial General Liability Insurance on a standard occurrence form, no less broad than Insurance Services Office (ISO) form CG 00 01.
- b. Minimum Limits: \$1,000,000 per Occurrence; \$2,000,000 General Aggregate; \$2,000,000 Products/Completed Operations Aggregate. The required limits may be provided by a combination of General Liability Insurance and Commercial Excess or Commercial Umbrella Liability Insurance. If Consultant maintains higher limits than the specified minimum limits, Sonoma Water requires and shall be entitled to coverage for the higher limits maintained by Consultant.
- c. Any deductible or self-insured retention shall be shown on the Certificate of Insurance. If the deductible or self-insured retention exceeds \$25,000 it must be approved in advance by Sonoma Water. Consultant is responsible for any deductible or self-insured retention and shall fund it upon Sonoma Water's written request, regardless of whether Consultant has a claim against the insurance or is named as a party in any action involving Sonoma Water.

- d. Sonoma County Water Agency and State of California, their officers, agents, and employees, shall be endorsed as additional insureds for liability arising out of operations by or on behalf of the Consultant in the performance of this Agreement.
- e. The insurance provided to the additional insureds shall be primary to, and non-contributory with, any insurance or self-insurance program maintained by them.
- f. The policy definition of “insured contract” shall include assumptions of liability arising out of both ongoing operations and the products-completed operations hazard (broad form contractual liability coverage including the “f” definition of insured contract in Insurance Services Office form CG 00 01, or equivalent).
- g. The policy shall cover inter-insured suits between the additional insureds and Consultant and include a “separation of insureds” or “severability” clause which treats each insured separately.
- h. Required Evidence of Insurance:
 - i. Copy of the additional insured endorsement or policy language granting additional insured status, and
 - ii. Certificate of Insurance.

1.3. Automobile Liability Insurance

- a. Minimum Limit: \$1,000,000 combined single limit per accident. The required limit may be provided by a combination of Automobile Liability Insurance and Commercial Excess or Commercial Umbrella Liability Insurance.
- b. Insurance shall cover all owned autos. If Consultant currently owns no autos, Consultant agrees to obtain such insurance should any autos be acquired during the term of this Agreement or any extensions of the term.
- c. Insurance shall cover hired and non-owned autos.
- d. Required Evidence of Insurance: Certificate of Insurance.

1.4. Standards for Insurance Companies

- a. Insurers, other than the California State Compensation Insurance Fund, shall have an A.M. Best's rating of at least A:VII.

1.5. Documentation

- a. The Certificate of Insurance must include the following reference: TW 18/19-003.
- b. All required Evidence of Insurance shall be submitted prior to the execution of this Agreement. Consultant agrees to maintain current Evidence of Insurance on file with Sonoma Water for the entire term of this Agreement and any additional periods if specified in Sections 1.1, 1.2, or 1.3, above.

- c. The name and address for mailing Additional Insured endorsements and Certificates of Insurance is: Sonoma County Water Agency, 404 Aviation Boulevard, Santa Rosa, CA 95403-9019.
- d. Required Evidence of Insurance shall be submitted for any renewal or replacement of a policy that already exists, at least ten (10) days before expiration or other termination of the existing policy.
- e. Consultant shall provide immediate written notice if: (1) any of the required insurance policies is terminated; (2) the limits of any of the required policies are reduced; or (3) the deductible or self-insured retention is increased.
- f. Upon written request, certified copies of required insurance policies must be provided within thirty (30) days.

1.6. Policy Obligations

- a. Consultant's indemnity and other obligations shall not be limited by the foregoing insurance requirements.

1.7. Material Breach

- a. If Consultant fails to maintain insurance which is required pursuant to this Agreement, it shall be deemed a material breach of this Agreement. Sonoma Water, at its sole option, may terminate this Agreement and obtain damages from Consultant resulting from said breach. Alternatively, Sonoma Water may purchase the required insurance, and without further notice to Consultant, Sonoma Water may deduct from sums due to Consultant any premium costs advanced by Sonoma Water for such insurance. These remedies shall be in addition to any other remedies available to Sonoma Water.



CERTIFICATE OF LIABILITY INSURANCE

DATE (MM/DD/YYYY)

8/28/2018

THIS CERTIFICATE IS ISSUED AS A MATTER OF INFORMATION ONLY AND CONFERS NO RIGHTS UPON THE CERTIFICATE HOLDER. THIS CERTIFICATE DOES NOT AFFIRMATIVELY OR NEGATIVELY AMEND, EXTEND OR ALTER THE COVERAGE AFFORDED BY THE POLICIES BELOW. THIS CERTIFICATE OF INSURANCE DOES NOT CONSTITUTE A CONTRACT BETWEEN THE ISSUING INSURER(S), AUTHORIZED REPRESENTATIVE OR PRODUCER, AND THE CERTIFICATE HOLDER.

IMPORTANT: If the certificate holder is an ADDITIONAL INSURED, the policy(ies) must have ADDITIONAL INSURED provisions or be endorsed. If SUBROGATION IS WAIVED, subject to the terms and conditions of the policy, certain policies may require an endorsement. A statement on this certificate does not confer rights to the certificate holder in lieu of such endorsement(s).

PRODUCER Arthur J. Gallagher & Co. Insurance Brokers of CA. LIC. # 0726293 505 N Brand Blvd, Suite 600 Glendale CA 91203	CONTACT NAME: Diane Gil PHONE (A/C. No. Ext): 818-539-8606 FAX (A/C. No):	
	E-MAIL ADDRESS: Diane_Gil@ajg.com	
INSURED BAYPLAN-01 Bay Planning Coalition 1970 Broadway, Suite 940 Oakland, CA 94612-2221		INSURER(S) AFFORDING COVERAGE INSURER A : Berkley National Insurance Company INSURER B : Markel Insurance Company INSURER C : INSURER D : INSURER E : INSURER F :
		NAIC # 38911 38970

COVERAGES

CERTIFICATE NUMBER: 1437940788

REVISION NUMBER:

THIS IS TO CERTIFY THAT THE POLICIES OF INSURANCE LISTED BELOW HAVE BEEN ISSUED TO THE INSURED NAMED ABOVE FOR THE POLICY PERIOD INDICATED. NOTWITHSTANDING ANY REQUIREMENT, TERM OR CONDITION OF ANY CONTRACT OR OTHER DOCUMENT WITH RESPECT TO WHICH THIS CERTIFICATE MAY BE ISSUED OR MAY PERTAIN, THE INSURANCE AFFORDED BY THE POLICIES DESCRIBED HEREIN IS SUBJECT TO ALL THE TERMS, EXCLUSIONS AND CONDITIONS OF SUCH POLICIES. LIMITS SHOWN MAY HAVE BEEN REDUCED BY PAID CLAIMS.

INSR LTR	TYPE OF INSURANCE	ADDL INSD	SUBR WVD	POLICY NUMBER	POLICY EFF (MM/DD/YYYY)	POLICY EXP (MM/DD/YYYY)	LIMITS
A	<input checked="" type="checkbox"/> COMMERCIAL GENERAL LIABILITY <input type="checkbox"/> CLAIMS-MADE <input checked="" type="checkbox"/> OCCUR GEN'L AGGREGATE LIMIT APPLIES PER: <input checked="" type="checkbox"/> POLICY <input type="checkbox"/> PRO-JECT <input type="checkbox"/> LOC OTHER:	Y		HHS85210112	5/11/2018	5/11/2019	EACH OCCURRENCE \$ 1,000,000 DAMAGE TO RENTED PREMISES (Ea occurrence) \$ 500,000 MED EXP (Any one person) \$ 10,000 PERSONAL & ADV INJURY \$ 1,000,000 GENERAL AGGREGATE \$ 3,000,000 PRODUCTS - COMP/OP AGG \$ 3,000,000 \$
A	AUTOMOBILE LIABILITY <input checked="" type="checkbox"/> ANY AUTO <input type="checkbox"/> OWNED AUTOS ONLY <input type="checkbox"/> SCHEDULED AUTOS <input checked="" type="checkbox"/> HIRED AUTOS ONLY <input checked="" type="checkbox"/> NON-OWNED AUTOS ONLY			HHS85210112	5/11/2018	5/11/2019	COMBINED SINGLE LIMIT (Ea accident) \$ 1,000,000 BODILY INJURY (Per person) \$ BODILY INJURY (Per accident) \$ PROPERTY DAMAGE (Per accident) \$ \$
	UMBRELLA LIAB <input type="checkbox"/> OCCUR EXCESS LIAB <input type="checkbox"/> CLAIMS-MADE DED <input type="checkbox"/> RETENTION \$						EACH OCCURRENCE \$ AGGREGATE \$ \$
B	WORKERS COMPENSATION AND EMPLOYERS' LIABILITY ANY PROPRIETOR/PARTNER/EXECUTIVE OFFICER/MEMBER EXCLUDED? (Mandatory in NH) If yes, describe under DESCRIPTION OF OPERATIONS below	Y/N	N/A	MWC012578201	3/23/2018	3/23/2019	<input checked="" type="checkbox"/> PER STATUTE <input type="checkbox"/> OTH-ER E.L. EACH ACCIDENT \$ 1,000,000 E.L. DISEASE - EA EMPLOYEE \$ 1,000,000 E.L. DISEASE - POLICY LIMIT \$ 1,000,000
A	Sexual Abuse Liability			HHS85210112	5/11/2018	5/11/2019	Per Claim \$ 1,000,000 Aggregate \$ 3,000,000

DESCRIPTION OF OPERATIONS / LOCATIONS / VEHICLES (ACORD 101, Additional Remarks Schedule, may be attached if more space is required)

Sonoma County Water Agency and State of California, their officers, agents, and employees, shall be endorsed as additional insureds for liability arising out of operations by or on behalf of the Consultant in the performance of this Agreement. Workers Compensation coverage is evidence only.

CERTIFICATE HOLDER**CANCELLATION**

Sonoma Water
 404 Aviation Boulevard
 Santa Rosa, CA 95403

SHOULD ANY OF THE ABOVE DESCRIBED POLICIES BE CANCELLED BEFORE THE EXPIRATION DATE THEREOF, NOTICE WILL BE DELIVERED IN ACCORDANCE WITH THE POLICY PROVISIONS.

AUTHORIZED REPRESENTATIVE

© 1988-2015 ACORD CORPORATION. All rights reserved.

Berkley National Insurance Company

THIS ENDORSEMENT CHANGES THE POLICY. PLEASE READ IT CAREFULLY.

ADDITIONAL INSURED – DESIGNATED PERSON OR ORGANIZATION

This endorsement modifies insurance provided under the following:

COMMERCIAL GENERAL LIABILITY COVERAGE PART

SCHEDULE

<p>Name Of Additional Insured Person(s) Or Organization(s): Sonoma County Water Agency and State of California, their officers, agents, and employees</p>
<p>Information required to complete this Schedule, if not shown above, will be shown in the Declarations.</p>

A. Section II – Who Is An Insured is amended to include as an additional insured the person(s) or organization(s) shown in the Schedule, but only with respect to liability for "bodily injury", "property damage" or "personal and advertising injury" caused, in whole or in part, by your acts or omissions or the acts or omissions of those acting on your behalf:

1. In the performance of your ongoing operations; or
2. In connection with your premises owned by or rented to you.

However:

1. The insurance afforded to such additional insured only applies to the extent permitted by law; and
2. If coverage provided to the additional insured is required by a contract or agreement, the insurance afforded to such additional insured will not be broader than that which you are required by the contract or agreement to provide for such additional insured.

B. With respect to the insurance afforded to these additional insureds, the following is added to **Section III – Limits Of Insurance:**

If coverage provided to the additional insured is required by a contract or agreement, the most we will pay on behalf of the additional insured is the amount of insurance:

1. Required by the contract or agreement; or
2. Available under the applicable Limits of Insurance shown in the Declarations;

whichever is less.

This endorsement shall not increase the applicable Limits of Insurance shown in the Declarations.



County of Sonoma Agenda Item Summary Report

Clerk of the Board
575 Administration Drive
Santa Rosa, CA 95403

Agenda Item Number: 9
(This Section for use by Clerk of the Board Only.)

To: Board of Directors, Sonoma County Water Agency

Board Agenda Date: November 13, 2018

Vote Requirement: 4/5

Department or Agency Name(s): Sonoma County Water Agency

Staff Name and Phone Number:

Lynne Rosselli, 524-3771

Supervisorial District(s):

Fourth

Title: Budget Resolution for the Airport-Larkfield-Wikiup Sanitation Zone and the Sonoma County Water Agency General Fund

Recommended Actions:

Adopt a Resolution ratifying and approving adjustments to the Board Adopted Budget for Fiscal Year 2018-2019 to transfer \$110,000 from the Sonoma County Water Agency General Fund to the Airport-Larkfield-Wikiup Sanitation Zone Rate Stabilization Fund, and \$211,500 from the Rate Stabilization Fund to the Airport-Larkfield-Wikiup Sanitation Zone Operations Fund to Comply with Airport-Larkfield-Wikiup Sanitation Zone Debt Financing Covenants.

Executive Summary:

On March 21, 2017, the Sonoma County Water Agency (Sonoma Water) Board of Directors authorized the Airport-Larkfield-Wikiup Sanitation Zone (Zone) to execute an installment sale agreement to refinance \$3,605,000 in prior debt. The Debt Installment Sale Agreement covenants that the Zone maintain net revenues equal to 120 percent of annual debt installment payments. Fiscal Year 2017/2018 installment payments were \$414,700, which means net revenues should be no less than \$497,640.

Staff recently learned that the Zone's net revenues in Fiscal Year 2017-18 would be less than the mandated 120 percent threshold due to a recent audit adjustment that corrected for the amount of revenue received. Under an existing agreement, the Zone receives revenue from the Occidental County Sanitation District (District) to offset costs associated with treatment and disposal of wastewater. As the result of an external audit, staff learned that the District overpaid the Zone by \$280,000 in Fiscal Year 2017/2018. Once the overpayment was corrected, financial audit adjustments revealed that the decrease in revenue would result in the Zone's net revenues being 69 percent of the annual installment payments, less than the mandated 120 percent threshold. In order to comply with the debt financing covenant, a transfer to the Zone's Operations Fund was required from the Zone's Rate Stabilization Fund in the amount of \$211,500, with \$110,000 of that coming from Sonoma Water's General Fund. This transfer from the Rate Stabilization fund will result in total revenues of \$4,836,826, total expenditures of \$4,338,604, and net revenues of \$498,222 in the Zone's Operations Fund for Fiscal Year 2017-18,

which brings the Zone into compliance with the net revenue threshold requirement. The debt financing covenant in the Debt Installment Sale Agreement requires that the transfer occur from the Rate Stabilization Fund within 120 days following the end of the fiscal year or by October 28, 2018.

This item requests that the Board adopt a resolution ratifying and approving adjustment to the Board Adopted Budget for Fiscal Year 2018-2019 to transfer \$110,000 from the Sonoma Water General Fund to the Zone's Rate Stabilization Fund, and \$211,500 from the Rate Stabilization Fund to the Zone's Operations Fund to Comply with the Zone's debt financing covenant. Noncompliance would result in negative financial reports to investors and grant agencies that would adversely impact the Zone's ability to successfully compete for future grants, loans, and bond funds.

Discussion:

On March 21, 2017, the Sonoma County Water Agency (Sonoma Water) Board of Directors authorized the Airport-Larkfield-Wikiup Sanitation Zone (Zone) to execute an installment sale agreement to refinance \$3,605,000 in prior debt that resulted in \$363,000 in present value savings with an interest rate of 2.33% and \$3,605,000 in outstanding principal amount. The Debt Installment Sale Agreement covenants that the Zone create a separate Rate Stabilization Fund and maintain net revenues equal to 120 percent of annual debt installment payments. Fiscal Year 2017/2018 installment payments were \$414,700. If net revenues are less than 120 percent of annual debt payments, the Zone must transfer funds from its Rate Stabilization Fund to its Operations Fund within 120 days following the end of the fiscal year or by October 28, 2018 to maintain compliance with the debt financing covenant in the installment sale agreement.

On April 3, 2018, the Board of Directors of the Occidental County Sanitation District (District) authorized the District to enter an agreement with a wastewater hauling provider to haul untreated wastewater from the District to the Zone's treatment plant for treatment and disposal in order to allow the District to comply with the North Coast Regional Water Quality Control Board's requirement to completely eliminate discharges to Graham's Pond and to eliminate seasonal discharges to Dutch Bill Creek. Under this agreement, the District pays the Zone for wastewater treatment and disposal costs in accordance with the provisions of the Zone's rate ordinance.

Recently, Sonoma Water's auditor, Pisenti and Brinker, requested additional documentation on the Fiscal Year 2017/2018 payment by the District to the Zone for treatment and disposal of the District's wastewater. When staff provided the additional documentation, they identified that an incorrect rate had been used to calculate the District's payment, resulting in an overpayment of \$280,000 in Fiscal Year 2017/2018 to the Zone. While making adjustments to the District's and Zone's audited financial statements to correct the error, staff at the County Auditor-Controller-Treasurer-Tax Collector informed Sonoma Water that the correction would result in the Zone's net revenues being 69 percent of the annual installment payments, less than the 120 percent mandated threshold.

In order to be in compliance with the debt financing covenant in the installment sale agreement, the County Auditor-Controller-Treasurer-Tax Collector recommended transfers to the Zone's Operations Fund from the Zone's Rate Stabilization Fund in the amount of \$211,500, which includes \$110,000 from Sonoma Water's General Fund, within 120 days following the end of the fiscal year or by October 28, 2018. One of the purposes of the rate stabilization fund is to restore net revenues in the event of a

shortfall. Since the rate stabilization fund only has a balance of \$100,500, \$110,000 is required from the Sonoma Water General Fund to make up the difference. Sonoma Water will return to the Board during the next quarterly consolidated budget adjustments with a recommendation for restoring the fund balance in the Zone’s Rate Stabilization Fund.

As deadlines for bringing this matter to the Board for approval prior to October 28, 2018 had passed, Sonoma Water staff with concurrence from the county administrator’s office, agreed to have the County Auditor-Controller-Treasurer-Tax Collector’s office and the county administrator’s office process the budget adjustments, and request Board ratification and approval at the November 13, 2018 Board meeting. The consequences of not having proceeded with the budget adjustments by the deadline would have been noncompliance with the debt financing covenant, and negative financial reports to investors and grant agencies that would adversely impact the Zone’s ability to successfully compete for future grants, loans, and bond funds.

RECOMMENDATION

Sonoma Water staff recommend that the Board adopt a resolution ratifying and approving adjustment to the Board Adopted Budget for Fiscal Year 2018-2019 to transfer \$110,000 from the Sonoma Water General Fund to the Zone’s Rate Stabilization Fund, and \$211,500 from the Rate Stabilization Fund to the Zone’s Operations Fund to Comply with the Zone’s debt financing covenant.

Prior Board Actions:

- 04/3/2018 Authorized Water Agency's General Manager acting on behalf of Occidental County Sanitation District to negotiate and execute an agreement, in a form approved by County Counsel, with a wastewater hauling provider through June 30, 2019, in the not-to-exceed amount of \$800,000.
- 3/21/2017 Resolutions authorizing execution of an Installment Sale Agreement between the Sonoma County Water and Wastewater Financing Authority and the Sonoma County Water Agency, for the Airport-Larkfield-Wikiup Sanitation Zone, to refinance \$3,605,000 in prior debt (Fourth District).

Strategic Plan Alignment Goal 2: Economic and Environmental Stewardship

Water Agency Sanitation Goals and Strategies, Goal 2: Provide adequate rate-based revenues, while pursuing new income and cost-cutting opportunities. This item supports Goal 2 by responsibly managing Water Agency finances.

Fiscal Summary			
Expenditures	FY 18-19 Adopted	FY 19-20 Projected	FY 20-21 Projected
Budgeted Expenses			
Additional Appropriation Requested	\$321,500		
Total Expenditures	\$321,500		
Funding Sources			
General Fund/WA GF			
State/Federal			
Fees/Other	\$321,500		
Use of Fund Balance			
Contingencies			
Total Sources	\$321,500		
Narrative Explanation of Fiscal Impacts:			
<p>With Board ratification and approval, FY 2018/2019 appropriations transferred \$110,000 from the Sonoma Water General Fund to the Zone's Rate Stabilization Fund, and \$211,500 from the Zone's Rate Stabilization Fund to the Zone's Operations Fund to restore net revenues for debt coverage pursuant to the attached budget adjustment supporting documentation and budgetary resolution (Attachment R1). The total transfers were \$321,500.</p>			
Staffing Impacts			
Position Title (Payroll Classification)	Monthly Salary Range (A – I Step)	Additions (Number)	Deletions (Number)
N/A			
Narrative Explanation of Staffing Impacts (If Required):			
N/A			
Attachments:			
Resolution R1			
Related Items "On File" with the Clerk of the Board:			
Budget Adjustment Supporting Documentation			

Date: November 13, 2018

Item Number: _____
Resolution Number: _____

4/5 Vote Required

Resolution Of The Board Of Directors of the Sonoma County Water Agency Ratifying and Approving Adjustments to the Board Adopted Budget for Fiscal Year 2018-2019 to transfer \$110,000 from the Sonoma County Water Agency General Fund to the Airport-Larkfield-Wikiup Sanitation Zone Rate Stabilization Fund, and \$211,500 from the Rate Stabilization Fund to the Airport-Larkfield-Wikiup Sanitation Zone Operations to Comply with Airport-Larkfield-Wikiup Sanitation Zone Debt Financing Covenants

Whereas, the Board of Directors of the Sonoma County Water Agency (Sonoma Water) adopted the Sonoma Water Fiscal Year 2018-2019 budget on June 15, 2018; and

Whereas, Sections 29088 through 29092 of the Government Code, State of California allow for adjustments to the Fiscal Year 2018-2019 Adopted Budget; and

Whereas, the Fiscal Year 2018-2019 Adopted Budget was adjusted for the Airport-Larkfield-Wikiup Sanitation Zone (Zone) Rate Stabilization Fund in the amount of \$211,500 and the Sonoma Water General Fund in the amount of \$110,000 to increase revenues in the Zone's Operations Fund by \$211,500 to comply with the Zone's debt financing covenants; and

Whereas, a resolution from Sonoma Water's governing board authorizing such budget adjustment is required.

Now, Therefore, Be It Resolved that the budgetary and accounting transfers and adjustments to the Sonoma Water Fiscal Year 2018-2019 budget completed by the County Auditor-Controller-Treasurer-Tax Collector and the County Administrator are hereby ratified and approved by the Sonoma Water Board of Directors as follows:

Resolution #

Date:

Page 2

Fiscal Year 2018-2019 Expenditures		Amount
44720-33100400	Airport-Larkfield-Wikiup Sanitation Zone (Zone) Rate Stabilization Fund	
57011	Transfers Out within a Fund to Zone Operations Fund	211,500.00
14015-33010100	General Fund	
57012	Transfers Out between Government Funds to Zone Rate Stabilization Fund	110,000.00
Total Expenditures		321,500.00
Fiscal Year 2018-2019 Funding Sources		
44705-33100100	Zone Operations Fund	
47101	Transfers in within a Fund (Transfer from Zone Rate Stabilization Fund)	211,500.00
44720-33100400	Zone Rate Stabilization Fund	
47102	Transfers In between Government Funds (Transfer from Sonoma Water General Fund)	110,000.00
Total Funding Sources		321,500.00

Directors:

Gorin: Rabbitt: Zane: Hopkins: Gore:

Ayes: Noes: Absent: Abstain:

So Ordered.



County of Sonoma Agenda Item Summary Report

Clerk of the Board
575 Administration Drive
Santa Rosa, CA 95403

Agenda Item Number:
(This Section for use by Clerk of the Board Only.)

To: County of Sonoma Board of Supervisors

Board Agenda Date: November 13, 2018

Vote Requirement: Majority

Department or Agency Name(s): Auditor-Controller-Treasurer-Tax Collector

Staff Name and Phone Number:

Amanda Ruch, Assistant ACTTC - 565-3274

Supervisorial District(s):

All

Title: Department Allocation Amendment

Recommended Actions:

Adopt a Personnel Resolution effective November 13, 2018, adding one (1 FTE) Department Information Systems Coordinator and deleting one (1 FTE) Department Analyst from the Auditor-Controller-Treasurer-Tax Collector's position allocation list.

Executive Summary:

The Auditor-Controller-Treasurer-Tax Collector's Office (ACTTC) is seeking to reinstate the Department Information Systems Coordinator (DISC) position it downgraded to a Department Analyst in 2010. Information technology has taken on an ever-increasing role in the workplace and the office's need for an on-site DISC has increased.

Human Resources has reviewed the job duties and determined that the DIS Coordinator is the appropriate classification for this position.

The DISC will work under general administrative direction and will be responsible for:

- managing security group and EFS access for 100+ employees; active directory account creation/migration for 22+ recruitments and numerous vendor hires per year; VPN access management and hardware support for the ACTTC's 26 active VPN users;
- supporting, installing, and relocating hardware as necessary;
- serving as the ISD liaison for Countywide projects; coordinate the office's DMP for 102+ users spread across three physical sites;
- training personnel and creating instruction materials for common IT needs as well as responding to user support requests;
- ADA remediation and electronic form creation;
- analyzing departmental IT requirements and researching and implementing solutions;

- creating, maintaining, and developing of the department's web presence across both the new web Content Management System and SharePoint sites;
- installing and supporting both department-specific and Countywide software;
- developing custom scripts or applications to improve department workflow and maximize the efficacy of departmental software; and
- providing support and administration for numerous department-specific systems or programs.

Discussion:

In August 2010, the Auditor-Controller-Treasurer-Tax Collector's Office (ACTTC) downgraded an existing Department Information Systems Coordinator (DISC) position to a Department Analyst. Over the last eight years, the office's size, reliance on information technology, and need for in-office expertise have grown, and the majority of these steadily increasing technology duties have been performed by the Administrative Services Officer and Department Analysts in the Administration Division.

The office is now seeking to reinstate its DIS Coordinator and delete one vacant Department Analyst position in the Administration Division.

The office currently has more than 101 active workstations and ~103 FTE employees and vendors spread across three physical sites. The office currently has no FTEs in the DIS classifications other than project-specific employees assigned to the HRMS and EFS projects. The office has numerous third-party applications and hardware support requirements, including the new Transient Occupancy Tax (TOT) administration system, Adaxes, Megabyte property tax system, Opex remittance processor, DMV, web Content Management System, Image Onsite and RTLawrence check imaging systems, C-Series check printing system, annual state reporting software, Columbia Ultimate Business Systems (CUBS), Simpler Systems, and many others. At the same time, even common applications are being put to increased use and need significant support--divisions are using Access databases that need SQL queries written for custom reports, visual basic scripts can improve departmental efficiency and automate repetitive tasks, and tax return forms now require ADA remediation and custom javascript logic. These scripts and queries must be both written and updated to account for changing business requirements.

As the office's technological needs have increased, so have the public's use of technology to interact with their local government. The ACTTC's workload creating and maintaining a web presence, whether that be ADA remediated documents, regularly updated information on the web, and fillable electronic forms, has come to demand a significant amount of staff time across all divisions as more documents than ever are placed online and each document requires more work than ever to improve accessibility. A dedicated DIS Coordinator will alleviate this workload and provide a subject-matter expert to both perform the duties and train and support line staff when working with these technologies.

Due to this ever-increasing technological workload, the ACTTC now requires a dedicated Department Information Systems Coordinator.

Prior Board Actions:

None

Strategic Plan Alignment Goal 2: Economic and Environmental Stewardship

The Auditor-Controller-Treasurer-Tax Collector's office performs many mandated services, including state financial reporting; property, cannabis, and transient occupancy tax collection and allocation; Americans with

Disabilities Act remediation for public reports; and more. Reinstating the DISC will allow the Auditor-Controller-Treasurer-Tax Collector to allocate proper support for these mandated services' IT needs.

Fiscal Summary

Expenditures	FY 18-19 Adopted	FY 19-20 Projected	FY 20-21 Projected
Budgeted Expenses		\$13,164	\$13,164
Additional Appropriation Requested			
Total Expenditures		\$13,164	\$13,164
Funding Sources			
General Fund/WA GF			
State/Federal			
Fees/Other		\$13,164	\$13,164
Use of Fund Balance			
Contingencies			
Total Sources		\$13,164	\$13,164

Narrative Explanation of Fiscal Impacts:

The DIS Coordinator salary will be allocated to the other divisions within the ACTTC consistent with how we currently allocate costs for the ACTTC Administrative staff, which will result in an incremental increase in department-wide revenues with no need for a current year or ongoing General Fund contribution to the ACTTC. Examples of the larger revenue streams for the ACTTC are as follows: Costs allocated to the Treasury and Investment functions are recovered via Treasury Admin Fees; costs allocated to the General and Client Accounting divisions are recovered primarily via accounting service charges to external and internal clients; costs allocated to the Enterprise Financial System are recovered via EFS rates. A de minimis amount of the additional cost will be included in the Cost Plan.

Staffing Impacts

Position Title (Payroll Classification)	Monthly Salary Range (A – I Step)	Additions (Number)	Deletions (Number)
Department Analyst	\$5,610 - \$6,820		1 FTE
Department Information Systems Coordinator	\$6,707 - \$8,152	1 FTE	

Narrative Explanation of Staffing Impacts (If Required):

Attachments:
A) Personnel Resolution
Related Items "On File" with the Clerk of the Board:
None



County of Sonoma

State of California

Date: November 13, 2018

Item Number: _____

Resolution Number: _____

4/5 Vote Required

Resolution Of The Board Of Supervisors Of The County Of Sonoma, State Of California,

Whereas, the Auditor-Controller-Treasurer-Tax Collector is requesting a change to the allocated job classification of Department Analyst assigned to the Administration Division, deleting the Department Analyst and adding a Department Information Systems Coordinator; and

Whereas, the Administration Division has a large role in managing the department's current Information Systems needs and it is expected that reliance on technology will continue to grow and it will take on an ever-larger role in governmental business; and

Whereas, the Department Analyst position is currently vacant;

Now, Therefore, Be It Resolved by the Board of Supervisors of the County of Sonoma that the Department Allocation List, Auditor-Controller-Treasurer-Tax Collector, be amended as follows:

EFS Department	Job Class and Title	Existing Allocation (FTE)	Change in Allocation (FTE)	New Total Allocation (FTE)	Duration/ End Date	Salary Range (month)
11010400	0826 Department Analyst	2.0	-1.0	1.0	Ongoing	\$5,610 - \$6,820
11010400	0160 Department Information Systems Coordinator	0.0	+1.0	1.0	Ongoing	\$6,707 - \$8,152
Total FTE Changes: 0.00						

Supervisors:

Gorin:

Rabbitt:

Zane:

Hopkins:

Gore:

Ayes:

Noes:

Absent:

Abstain:

So Ordered.



County of Sonoma Agenda Item Summary Report

Clerk of the Board
575 Administration Drive
Santa Rosa, CA 95403

Agenda Item Number: 11
(This Section for use by Clerk of the Board Only.)

To: Board of Supervisors of the County of Sonoma

Board Agenda Date: November 13, 2018

Vote Requirement: Unanimous

Department or Agency Name(s): Auditor-Controller-Treasurer-Tax Collector

Staff Name and Phone Number:

Randy Siple, 565-3671

Supervisorial District(s):

Title: Northern Sonoma County Air Pollution Control District Fiscal Audit Frequency–Biennial

Recommended Actions:

Adopt Resolution in support of the Northern Sonoma County Air Pollution Control District performing biennial fiscal audits.

Executive Summary:

The County of Sonoma Auditor-Controller-Treasurer-Tax Collector (ACTTC) is requesting that the Board of Supervisors of the County of Sonoma unanimously adopt a resolution to change the Northern Sonoma County Air Pollution Control District (District) audit frequency from an annual schedule to a biennial schedule. A corresponding resolution has already been adopted by the District's Board of Directors and is attached to this item. ACTTC has vetted this action and is in support of this change in fiscal audit frequency.

Discussion:

California Government Code §26909 mandates that the county auditor shall either make or contract with a certified public accountant or public accountant to make an annual audit of the accounts and records of every special district within the county. The Northern Sonoma County Air Pollution Control District (District) is one such applicable special district. Currently, the County of Sonoma (ACTTC) contracts an annual audit service on behalf of the District with an outside firm. Subsection (b)(1) of §26909 provides that a District may shift to a biennial audit schedule if the District's Board of Directors unanimously requests it and the County Board of Supervisors unanimously vote in favor of it. The District's Board of Directors unanimously adopted the request for a biennial schedule at their September 5, 2018 meeting.

For the last four fiscal year audits, ACTTC has contracted with Pimenti and Brinker on behalf of the District to perform the annual audits at a cost of approximately \$20,000 per audit, to the District. In addition to this contract cost, each audit report also requires assignment of additional District and ACTTC staff resources. As the District utilizes County Treasury, accounting services, and policies, there are robust fiscal controls in place on the District's finances and fiscal activity. The District's accounts and transactions are straightforward and have not substantively changed in over 20 years nor have they had audit issues.

Given these points, District staff proposes a biennial instead of annual, audit schedule, as allowable by the California Government Code.

ACTTC staff has discussed this proposal with the District. ACTTC has reviewed this proposal, and finds the request appropriate, and supports the District’s proposal to move to biennial audits. This is not an uncommon practice at other air districts in the state. Of note, while the audits would be biennial in frequency, they would encompass a complete audit for the full two-year period. This biennial schedule will save time and money over the annual audit schedule.

Prior Board Actions:

District Board of Directors Resolution 18-11; attached

Strategic Plan Alignment Goal 2: Economic and Environmental Stewardship

Protect air quality in the northern Sonoma County region

Fiscal Summary

Expenditures	FY 18-19 Adopted	FY 19-20 Projected	FY 20-21 Projected
Budgeted Expenses			
Additional Appropriation Requested			
Total Expenditures			

Funding Sources

General Fund/WA GF			
State/Federal			
Fees/Other			
Use of Fund Balance			
Contingencies			
Total Sources			

Narrative Explanation of Fiscal Impacts:

The District pays the costs of the audit to the ACTTC. There is no direct fiscal impact to the County, however this shift will result in a reduction of District and ACTTC staff resources needed to support the audit.

Staffing Impacts

Position Title (Payroll Classification)	Monthly Salary Range (A – I Step)	Additions (Number)	Deletions (Number)

Narrative Explanation of Staffing Impacts (If Required):			
Attachments:			
Attachment #1 District Board of Directors Resolution 18-11 Attachment #2 County Resolution			
Related Items "On File" with the Clerk of the Board:			



Board Resolution:
#18-11

Before the Northern Sonoma County Air Pollution Control District Board of Directors

In the Matter of: Fiscal Audit Frequency Request

The following **RESOLUTION** was duly passed by the Northern Sonoma County Air Pollution Control District Board of Directors at a regular meeting held on **September 5, 2018**, by the following vote:

Ayes: Salmon Hopkins Bagby Gold Gore
Alternates: _____

Noes: Salmon _____ Hopkins _____ Bagby _____ Gold _____ Gore _____
Alternates: _____

Abstain: Salmon _____ Hopkins _____ Bagby _____ Gold _____ Gore _____
Alternates: _____

Signed and approved by me after its passage:

 Chairperson

WHEREAS, California Government Code §26909 requires state Special Districts, which include the Northern Sonoma County Air Pollution Control District, to perform annual fiscal audits performed by a Certified Public Accountant or Public Accountant;

AND WHEREAS, the Northern Sonoma County Air Pollution Control District is requesting the fiscal audit frequency provision of California Government Code §26909(b): A special district may, by unanimous request of the governing board of the special district, with unanimous approval of the board of supervisors, replace the annual audit required by this section with one of the following, performed in accordance with professional standards, as determined by the county auditor:

- (1) A biennial audit covering a two-year period.

AND WHEREAS, the Northern Sonoma County Air Pollution Control District exclusively utilizes County Treasury and accounting services under contract, and thereby implements all applicable county fiscal policies which provides for consistent and safe fiscal operations;

AND WHEREAS, the Northern Sonoma County Air Pollution Control District budget is relatively uncomplicated and has not been problematic in fiscal or operational matters, and the

County of Sonoma Auditor-Controller-Treasurer-Tax Collector ("ACTTC") finds the move from an annual to biennial audit to be a reasonable request and to be appropriate to maintain fiscal accountability and controls, thereby supporting the District in this request;

AND WHEREAS, the California State Controller's Office requires the Northern Sonoma County Air Pollution Control District Board of Directors unanimous request and the unanimous approval of the Sonoma County Board of Supervisors to replace the annual audit with a biennial audit;

NOW THEREFORE, BE IT RESOLVED that the Northern Sonoma County Air Pollution Control District hereby unanimously requests the Sonoma County Board of Supervisors to approve a biennial audit covering a two-year period.



County of Sonoma

State of California

Date: November 13, 2018

Item Number: _____

Resolution Number: _____



4/5 Vote Required

Resolution Of The Board Of Supervisors Of The County Of Sonoma, State Of California,

Whereas, California Government Code §26909 requires Special Districts, which include the Northern Sonoma County Air Pollution Control District, to perform annual fiscal audits performed by a Certified Public Accountant or Public Accountant; and

Whereas, the Northern Sonoma County Air Pollution Control District is requesting the fiscal audit frequency provision of California Government Code §26909(b): A special district may, by unanimous request of the governing board of the special district, with unanimous approval of the board of supervisors, replace the annual audit required by this section with one of the following, performed in accordance with professional standards, as determined by the county auditor:

- (1) A biennial audit covering a two-year period;
- and

Whereas, the Northern Sonoma County Air Pollution Control District exclusively utilizes County Treasury and accounting services under contract, and thereby implements all applicable county fiscal policies which provides for consistent and safe fiscal operations; and

Whereas, the Northern Sonoma County Air Pollution Control District budget is relatively uncomplicated and has not been problematic in fiscal or operational matters, and the County of Sonoma Auditor-Controller-Treasurer-Tax Collector ("ACTTC") finds the move from an annual to biennial audit to be a reasonable request and to be appropriate to maintain fiscal accountability and controls, thereby supporting the District in this request; and

Whereas, the California State Controller's Office requires the Northern Sonoma County Air Pollution Control District Board of Directors unanimously request, and receive the unanimous approval of the Sonoma County Board of Supervisors, to replace the annual audit with a biennial audit.

Now, Therefore, Be It Resolved that the Sonoma County Board of Supervisors hereby

Resolution #

Date:

Page 2

acknowledges the request of the Board of Directors of the Northern Sonoma County Air Pollution Control District, and approves for the Northern Sonoma County Air Pollution Control District a biennial audit covering a two-year period.

Supervisors:

Gorin:

Rabbitt:

Zane:

Hopkins:

Gore:

Ayes:

Noes:

Absent:

Abstain:

So Ordered.



County of Sonoma Agenda Item Summary Report

Clerk of the Board
575 Administration Drive
Santa Rosa, CA 95403

Agenda Item Number: 12

(This Section for use by Clerk of the Board Only.)

To: Sonoma County Board of Supervisors

Board Agenda Date: November 13, 2018

Vote Requirement: Majority

Department or Agency Name(s): Auditor-Controller-Treasurer-Tax Collector and County Counsel

Staff Name and Phone Number:

Amanda Ruch 565-3724
Lauren Walker 565-2421

Supervisorial District(s):

Title: Authorizing Examination of Sales and Transaction Use Tax Records; Civitas Advisors, Inc.

Recommended Actions:

Adopt a Resolution Authorizing the Examination of Sales and Transaction and Use Tax Records, and Signature of Sales, Transactions, and Use Tax Information Nondisclosure Agreement

Executive Summary:

The Sonoma Valley Vintners and Growers Alliance has contracted with Civitas Advisors, Inc. to consider forming a business improvement district in Sonoma Valley to create jobs, attract and retain businesses, and promote economic growth and revitalization. To examine this possibility and determine potential assessment methods, Civitas must analyze the County's sales tax data. State law requires that the Board pass a resolution authorizing access to sales tax data, and the County to enter into an agreement with the entity receiving the data to ensure confidentiality of the information.

Discussion:

California law allows for local government agencies to form a business improvement district ("BID") in order to create jobs, attract and retain businesses, and promote economic growth and revitalization. As part of a BID, improvements, maintenance, and/or activities are funded through the levy of assessments upon the businesses or real property that receive benefits from the funded improvements or activities. This process has been used previously in creating the Sonoma Tourism Improvement District ("STID"). As part of the STID, inns and other lodging establishments located within the City (the District's boundary) are assessed two percent of gross room night sales to fund marketing and other programs to increase overnight stays.

More recently, the concept of a BID has been used by various restaurant groups and associations throughout the State to form restaurant and/or beverage improvement districts. Under this model, restaurants and/or food and drink establishments pay an assessment, which is collected by the local government and managed by a non-profit organization, to fund marketing campaigns, special events and promotions to increase sales. The Sonoma Valley Vintners and Growers Alliance is currently

exploring the interest in forming such a district in the Sonoma Valley area with wineries and tasting rooms. It is working with Civitas Advisors, Inc. (“Civitas”) in this process.

As part of this effort, it is recommended that Civitas be authorized to examine the County's sales and use tax records. Civitas is a specialized firm with experience in assisting local governments and groups in forming various types of business improvement districts, including hospitality improvement, restaurant improvement, and beverage improvement districts respectively. Given the confidential nature of this data, State law requires the governing body to adopt a resolution of authorization granting access to the data. The Board adopted a similar resolution in 1992 to grant access to HdL, the County’s sales tax consultant, the CAO, and the ACTTC. The proposed resolution expands on this authority to grant Civitas access to the County’s sales tax records.

In addition to the resolution authorizing access, State law also requires that the County enter into a contract with the entity that is granted access. As Civitas is not already in contract with the County of Sonoma, staff also recommends adopting a Nondisclosure Agreement between Civitas and the County.

The examination of the sales and use tax records will help determine the various assessment methodologies that could be used to form a district. Data acquired will not be shared with anyone beyond Civitas.

Prior Board Actions:

December 8, 1992: Adopt a resolution granting sales tax data access to CAO, ACTTC, and HdL.

Strategic Plan Alignment Goal 2: Economic and Environmental Stewardship

Allowing Civitas access to the County’s sales tax data will assist the SVVGA in potentially forming a self-sustaining funding source for marketing purposes.

Fiscal Summary			
Expenditures	FY 18-19 Adopted	FY 19-20 Projected	FY 20-21 Projected
Budgeted Expenses			
Additional Appropriation Requested			
Total Expenditures			
Funding Sources			
General Fund/WA GF			
State/Federal			
Fees/Other			
Use of Fund Balance			
Contingencies			
Total Sources			
Narrative Explanation of Fiscal Impacts:			
None			
Staffing Impacts			
Position Title (Payroll Classification)	Monthly Salary Range (A – I Step)	Additions (Number)	Deletions (Number)
Narrative Explanation of Staffing Impacts (If Required):			
Attachments:			
Sales, Transactions, and Use Tax Information Nondisclosure Agreement Draft Board of Supervisors Resolution Authorizing the Examination of Sales and Transactions and Use Tax Records			
Related Items “On File” with the Clerk of the Board:			

Sales, Transactions, and Use Tax Information Nondisclosure Agreement

This Nondisclosure Agreement (the "Agreement") is entered into on this _____ day of November, 2018 by and between the County of Sonoma with its principal offices at 575 Administrative Drive, Santa Rosa, CA 95403 ("Disclosing Party") and Civitas Advisors, Inc., a California corporation with its principal offices at 1102 Corporate Way, Suite 140, Sacramento California 95831 ("Receiving Party") for the purpose of preventing the unauthorized disclosure of Confidential Information as defined below. The parties agree to enter into a confidential relationship with respect to the disclosure of certain proprietary and confidential information ("Confidential Information").

1. **Definition of Confidential Information.** For purposes of this Agreement, "Confidential Information" shall include all information or material regarding sales, transactions, and use taxes collected by or behalf of Disclosing Party which is being provided to Receiving Party.

2. **Exclusions from Confidential Information.** Receiving Party's obligations under this Agreement do not extend to information that is publicly known at the same time of disclosure or subsequently becomes publicly known through no fault of the Receiving Party.

3. Obligations of Receiving Party.

A. Receiving Party shall hold and maintain the Confidential Information in strictest confidence. Receiving Party shall carefully restrict access to Confidential Information to employees, contractors and third parties as is reasonably required and shall require those persons to sign nondisclosure restrictions at least as protective as those in this Agreement. Notwithstanding the foregoing, Receiving Party shall not disclose to any third party the gross receipts of any person or entity paying sales, transactions, or use taxes to the Disclosing Party, or the amount of sales, transactions, or use taxes tax generated by any person or entity. Receiving Party shall not use for Receiving Party's own benefit, publish, copy, or otherwise disclose to others, or permit the use by others for their benefit to the detriment of Disclosing Party, any Confidential Information. Receiving Party shall return to Disclosing Party any and all records, notes, and other written, printed, or tangible materials in its possession pertaining to Confidential Information immediately if Disclosing Party requests it in writing. Any report prepared by Receiving Party using Confidential Information shall be written in such a way as to preclude the identification of individual business or individual tax payers by reading the report, provided that this shall not prohibit the preparation and distribution of a report listing persons or entities without disclosure of their respective gross receipts or the amount of sales, transactions, or use taxes generated.

B. Receiving Party shall only disclose the Confidential Information, including any information contained in or derived from the Confidential Information, to the officer or employee designated by Resolution of the Disclosing Party.

C. Receiving Party is prohibited by this Agreement from performing consulting services for a retailer during the term of this Agreement.

D. Receiving Party is prohibited by this Agreement from retaining the Confidential Information, including and information contained in or derived from the Confidential Information, after this Agreement has been terminated.

4. **Time Periods.** The nondisclosure provisions of this Agreement shall survive the termination of this Agreement and Receiving Party's duty to hold Confidential Information in confidence shall remain in effect until Disclosing Party sends Receiving Party written notice terminating this Agreement. Receiving Party shall provide all Confidential Information, including and information contained in or derived from the Confidential Information, to Disclosing Party within ten (10) days of receiving notice of termination of this Agreement.

5. **Costs.** Should Disclosing Party's revenues be deducted by any cost of Receiving Party's request as required by California Revenue and Taxation Code 7056(b), Receiving Party shall reimburse Disclosing Party for such costs.

6. **Relationships.** Nothing contained in this Agreement shall be deemed to constitute either party a partner, joint venturer or employee of the other party for any purpose.

7. **Severability.** If a court finds any provision of this Agreement invalid or unenforceable, the remainder of this Agreement shall be interpreted so as best to effect the intent of the parties.

8. **Integration.** This Agreement expresses the complete understanding and entire agreement of the parties with respect to the subject matter and supersedes all prior proposals, agreements, representations and understandings. This Agreement may not be amended except in a writing signed by both parties.

9. **Waiver.** The failure to exercise any right provided in this Agreement shall not be a waiver of prior or subsequent rights.

10. **Interpretation and Presumption.** This Agreement shall be interpreted in accordance with California law. It is the parties' express intent that no presumption shall arise from the identity of the drafter.

11. **Indemnification.** Receiving Party shall defend, indemnify, and hold harmless Disclosing Party from and against any and all claims, damages, losses, and causes of action which may be asserted against or suffered by Disclosing Party arising out of the receipt of Confidential Information by Receiving Party, its subsequent disclosure, and/or any breach by Receiving Party of its obligations under this Agreement.

12. **Attorneys Fees and Costs.** In the event of litigation between the parties concerning the interpretation, implementation, or termination of this agreement the prevailing party in such litigation shall, upon order of the court, be entitled to recover its reasonable attorney's fees, expert witness fees, and costs.

///

This Agreement and each party's obligations shall be binding on the representatives, assigns and successors of such party. Each party has signed this Agreement through its authorized representative.

Civitas Advisors, Inc:

COUNTY: COUNTY OF SONOMA

By: _____

John Lambeth, President

APPROVED AS TO FORM FOR COUNTY:

Date: _____

By: _____

County Counsel

By: _____

Rachael Taylor, Project Manager

Date: _____

Date: _____

AGREEMENT EXECUTED:

By: _____

Chair, Board of Supervisors

Date: _____

ATTEST:

Clerk of the Board of Supervisors

Date: _____



County of Sonoma

State of California

Date: November 13, 2018

Item Number: _____
Resolution Number: _____

4/5 Vote Required

Resolution Of The Board Of Supervisors Of The County Of Sonoma, State Of California, Authorizing the Examination of Sales and Transactions and Use Tax Records

Whereas, the County of Sonoma (“County”) contracts with the California Department of Tax and Fee Administration, formerly named the State Board of Equalization (“SBOE”), to perform all functions incident to the administration and collection of local sales and use taxes and local transactions and use taxes; and

Whereas, the Board of Supervisors of the County deems it necessary for an authorized representative of the County to examine confidential sales and transactions and use tax records of the SBOE pertaining to sales and transactions and use taxes collected by the SBOE for the County; and

Whereas, Section 7056 of the California Revenue and Taxation Code sets forth certain requirements and conditions for the disclosure of SBOE records and establishes criminal penalties for the unlawful disclosure of information contained in, or derived from sales and transactions and use tax records of the SBOE; and

Whereas, Section 7056 of the California Revenue and Taxation Code requires that any person designated by the County shall have an existing contract to examine the County’s sales and transactions and use tax records; and

Whereas, the County has contracted with Hinderliter, de Lamas and Associates (“HdL”) to assist the County with sales tax and economic analysis, allocation and audit recovery services, and other consulting services; and

Whereas, the Sonoma Valley Vintners & Growers Alliance (“SVVGA”) has contracted with Civitas Advisors, Inc. (“Civitas”) to assist SVVGA with determining the feasibility of forming a wine and agricultural heritage district and the facilitation of forming such a district if warranted.

Now, Therefore, Be It Resolved

1. The recitals set forth herein are adopted by the Board of Supervisors as findings and they are true and correct.

2. The Sonoma County County Administrative Officer ("CAO"), Sonoma County Auditor-Controller Treasurer-Tax Collector ("ACTTC"), and Civitas Account Manager, or other officer or employee of the County designated in writing by the CAO or ACTTC to the SBOE is hereby appointed to represent the County with authority to examine all of the sales or transactions and use tax records of the SBOE pertaining to sales and transaction and use taxes collected for the County by the SBOE pursuant to the contract between the County and the SBOE under the Bradley-Burns Uniform Local Sales and Use Tax Law or the Transactions and Use Tax Law. The information obtained by examination of SBOE records shall be used only for purposes related to the collection of County sales and transaction and use taxes by the SBOE pursuant to the contract.

3. HdL is hereby designated to examine the sales and transactions and use tax records of the SBOE pertaining to sales and transactions and use taxes collected for the County by the SBOE and provide such records to Civitas. The person or entity designated by this section meets all of the following conditions:

a. Has an existing contract with the County to examine sales and transactions and use tax records;

b. Is required by that contract to disclose information contained in, or derived from those sales and transactions and use tax records only to the officer or employee authorized under Section 2 of this resolution to examine the information;

c. Is prohibited by that contract from performing consulting services for a retailer during the term of that contract; and

d. Is prohibited by that contract from retaining the information contained in, or derived from those sales and transactions and use tax records after that contract has expired.

4. Civitas is hereby designated to examine the sales and transactions and use tax records of the SBOE pertaining to sales and transactions and use taxes collected for the County by the SBOE and use such records for the purpose of preparing documents related to the formation of a wine and agricultural heritage district. The person or entity designated by this section meets all of the following conditions:

a. Has an existing contract with the County to examine sales and transactions and use tax records;

Resolution #

Date: November 13, 2018

Page 3

b. Is required by that contract to disclose information contained in, or derived from those sales and transactions and use tax records only to the officer or employee authorized under Section 2 of this resolution to examine the information;

c. Is prohibited by that contract from performing consulting services for a retailer during the term of that contract; and

d. Is prohibited by that contract from retaining the information contained in, or derived from those sales and transactions and use tax records after that contract has expired.

Be It Further Resolved that the information obtained by examination of SBOE records shall be used only for purposes related to the collection of County's sales and transactions and use taxes by the SBOE pursuant to the contract between the County and the SBOE.

Supervisors:

Gorin:

Rabbitt:

Zane:

Hopkins:

Gore:

Ayes:

Noes:

Absent:

Abstain:

So Ordered.



County of Sonoma Agenda Item Summary Report

Clerk of the Board
575 Administration Drive
Santa Rosa, CA 95403

Agenda Item Number: 13
(This Section for use by Clerk of the Board Only.)

To: Board of Supervisors

Board Agenda Date: November 13, 2018

Vote Requirement: Majority

Department or Agency Name(s): Board of Supervisors

Staff Name and Phone Number:

Board of Supervisors 565-2241

Supervisorial District(s):

Countywide

Title: Board of Supervisors Calendar of Meetings for 2019

Recommended Actions:

Approve the County of Sonoma Board of Supervisors calendar of meetings for the year 2018.

Executive Summary:

The Board Chair has proposed the calendar of meetings for the year 2019.

Discussion:

Prior Board Actions:

Strategic Plan Alignment Goal 4: Civic Services and Engagement

Fiscal Summary			
Expenditures	FY 18-19 Adopted	FY 19-20 Projected	FY 20-21 Projected
Budgeted Expenses			
Additional Appropriation Requested			
Total Expenditures			
Funding Sources			
General Fund/WA GF			
State/Federal			
Fees/Other			
Use of Fund Balance			
Contingencies			
Total Sources			
Narrative Explanation of Fiscal Impacts:			
Staffing Impacts			
Position Title (Payroll Classification)	Monthly Salary Range (A – I Step)	Additions (Number)	Deletions (Number)
Narrative Explanation of Staffing Impacts (If Required):			
Attachments:			
Board of Supervisors 2019 meeting calendar			
Related Items "On File" with the Clerk of the Board:			

January 2019

Sunday	Monday	Tuesday	Wednesday	Thursday	Friday	Saturday
		1 New Year's Day	2	3	4	5
6	7	8 8:30a.m. Board Meeting	9	10	11	12
13	14	15 8:30a.m.- 12:00 p.m. Quarterly Hazard Workshop (Floods)	16	17	18	19
20	21 Martin Luther King	22	23	24	25	26
27	28	29 8:30a.m. Board Meeting	30	31	Notes:	

February 2019

Sunday	Monday	Tuesday	Wednesday	Thursday	Friday	Saturday
					1 State	2
3	4	5 8:30a.m. Board Meeting	6	7	8	9
10	11	12 Lincoln's Birthday Holiday	13	14	15	16
17	18 Presidents Day	19	20	21	22	23
24	25 Special Closed Session Board Meeting (All Day)	26 8:30a.m. Board Meeting (CONSENT ITEMS ONLY)	27	28	Notes:	

March 2019

Sunday	Monday	Tuesday	Wednesday	Thursday	Friday	Saturday
					1	2 NACo DC Legislative Conf
3 NACo DC Legislative Conf	4 NACo DC Legislative Conf	5 NACo DC Legislative Conf	6 NACo DC Legislative Conf	7	8	9
10	11	12 8:30a.m. Board Meeting	13	14	15	16
17	18	19 8:30a.m. Board Meeting	20	21	22	23
24	25	26 Special Closed Session Board Meeting (All Day)	27	28	29	30
31	Notes:					

April 2019

Sunday	Monday	Tuesday	Wednesday	Thursday	Friday	Saturday
	1 Cesar Chavez Day	2 8:30a.m. Board Meeting /Quarterly Hazard Workshop (Earthquakes)	3	4	5	6
7	8	9 8:30a.m. Board Meeting /Functional area budget workshops (CONSENT ITEMS ONLY)	10 Functional area budget workshops	11	12	13
14	15	16 8:30a.m. Board Meeting	17	18	19 Good Friday	20
21 Easter	22	23	24 CSAC Leg Conf	25 CSAC Leg Conf	26	27
28	29	30 8:30a.m. Board Meeting	Notes:			

May 2019

Sunday	Monday	Tuesday	Wednesday	Thursday	Friday	Saturday
			1	2	3	4
5	6	7 Special Closed Session Board Meeting (All Day)	8	9	10	11
12	13	14 8:30a.m. Board Meeting	15	16	17	18
19	20	21 8:30a.m. Board Meeting	22	23	24	25
26	27 Memorial Day	28	29	30	31	Notes:

June 2019

Sunday	Monday	Tuesday	Wednesday	Thursday	Friday	Saturday
						1
2	3	4 8:30a.m. Board Meeting	5	6	7	8
9	10	11 8:30a.m. Board Meeting	12 Budget Hearings	13 Budget Hearings	14 Budget Hearings	15
16	17 Budget Hearings	18 Budget Hearings	19 Budget Hearings	20 Budget Hearings	21 Budget Hearings	22
23	24	25	26	27	28	29
30	Notes:					

July 2019

Sunday	Monday	Tuesday	Wednesday	Thursday	Friday	Saturday
	1	2	3	4 <i>Indep. Day</i>	5	6
7	8	9 <i>8:30a.m. Board Meeting /Quarterly Hazard Workshop (Wildfires)</i>	10	11 <i>NACO Annual Conf</i>	12 <i>NACO Annual Conf</i>	13 <i>NACO Annual Conf</i>
14 <i>NACO Annual Conf</i>	15 <i>NACO Annual Conf</i>	16	17	18	19	20
21	22	23 <i>8:30a.m. Board Meeting</i>	24	25	26	27
28	29	30 <i>Special Closed Session Board Meeting (All Day)</i>	31	Notes:		

August 2019

Sunday	Monday	Tuesday	Wednesday	Thursday	Friday	Saturday
				1	2	3
4	5	6 8:30a.m. Board Meeting	7	8	9	10
11	12	13 8:30a.m. Board Meeting	14	15	16	17
18	19	20 8:30a.m. Board Meeting	21	22	23	24
25	26	27 Special Closed Session Board Meeting (All Day)	28	29	30	31

September 2019

Sunday	Monday	Tuesday	Wednesday	Thursday	Friday	Saturday	
1	2 Labor Day	3	4	5	6	7	
8	9	10 8:30a.m. Board Meeting	11	12	13	14	
15	16	17 8:30a.m. Board Meeting	18	19	20	21	
22	23	24 8:30a.m. Board Meeting	25	26	27	28	
29	30	Notes:					

October 2019

Sunday	Monday	Tuesday	Wednesday	Thursday	Friday	Saturday
		1 Special Closed Session Board Meeting (All Day)	2	3	4	5
6	7	8 8:30a.m. Board Meeting	9	10	11	12
13	14	15 8:30a.m. Board Meeting	16	17	18	19
20	21	22 8:30a.m. Board Meeting	23	24	25	26
27	28	29	30	31	Notes:	

November 2019

Sunday	Monday	Tuesday	Wednesday	Thursday	Friday	Saturday
					1	2
3	4	5 8:30a.m. Board Meeting /Quarterly Hazard Workshop (Cyber security)	6	7	8	9
10	11 Veteran's Day	12 Special Closed Session Board Meeting (All Day)	13	14	15	16
17	18	19 8:30a.m. Board Meeting	20	21	22	23
24	25	26	27	28 Thanksgiving	29 Thanksgiving	30

Notes:

December 2019

Sunday	Monday	Tuesday	Wednesday	Thursday	Friday	Saturday
1	2	3 CSAC Annual Conference Los Angeles	4 CSAC Annual Conference Los Angeles	5 CSAC Annual Conference Los Angeles	6 CSAC Annual Conference Los Angeles	7
8	9	10 8:30a.m. Board Meeting	11	12	13	14
15	16	17 8:30a.m. Board Meeting	18	19	20	21
22	23	24	25 Christmas	26	27	28
29	30	31	Notes:			



County of Sonoma Agenda Item Summary Report

Clerk of the Board
575 Administration Drive
Santa Rosa, CA 95403

Agenda Item Number: 14
(This Section for use by Clerk of the Board Only.)

To: Board of Supervisors

Board Agenda Date: November 13, 2018

Vote Requirement: Majority

Department or Agency Name(s): Sonoma County Office of Education

Staff Name and Phone Number:

Steven Herrington, PhD – (707) 524-2620

Supervisorial District(s):

All

Title: Sonoma County Williams Act Settlement Annual Report of Findings

Recommended Actions:

Accept Sonoma County Superintendent of Schools Report on Williams Lawsuit Settlement findings for Fiscal Year 2017-2018

Executive Summary:

In August 2004, the Governor facilitated a settlement of the Williams lawsuit with specific legislation (CA Education Code Section 1240) designed to identify and correct deficiencies, which may be impediments to student academic success. This legislation stemmed from a lawsuit by the American Civil Liberties Union (ACLU) that the State of California failed to provide poor and underprivileged students with equal educational opportunities. Specific elements in the suit included inadequate school facilities, insufficient educational materials, and a lack of fully credentialed teachers.

Pursuant to the Williams Settlement, the County Superintendent of Schools is required to report to the Board of Supervisors the results of findings related to those elements or conditions of Sonoma County schools. Attached is the report summarizing the June 2017 audit and visitation findings of the first four weeks of the 2017-2018 school year.

Discussion:

Sonoma County Office of Education Superintendent Steve Harrington will be presenting the report. The Board is requested to accept the report.

Prior Board Actions:

Strategic Plan Alignment Goal 3: Invest in the Future

Validating the presence of sufficient, current, standards based instructional materials in all Sonoma County school districts ensures young students in the community have necessary materials to enhance educational opportunities.

Fiscal Summary			
Expenditures	FY 16-17 Adopted	FY 17-18 Projected	FY 18-19 Projected
Budgeted Expenses			
Additional Appropriation Requested			
Total Expenditures			
Funding Sources			
General Fund/WA GF			
State/Federal			
Fees/Other			
Use of Fund Balance			
Contingencies			
Total Sources			
Narrative Explanation of Fiscal Impacts:			
No fiscal impact for this item.			
Staffing Impacts			
Position Title (Payroll Classification)	Monthly Salary Range (A – I Step)	Additions (Number)	Deletions (Number)
Narrative Explanation of Staffing Impacts (If Required):			
None.			
Attachments:			
Sonoma County Williams Act Settlement Annual Report of Findings			
Related Items "On File" with the Clerk of the Board:			
None.			

September 25, 2018

Sonoma County Board of Supervisors
575 Administration Drive, Room 100A
Santa Rosa, CA 95403

Sonoma County Board of Supervisors:

Enclosed please find the Annual Report of Findings Pursuant to Williams Lawsuit Settlement for the fiscal year 2018-19. There were a total of twenty-three schools monitored.

Under Education Code Section 1240, each year the County Superintendent of Schools must report to the Board of Supervisors the results of findings regarding inadequate school facilities, school accountability report cards and teacher qualifications.

Please let me know if I can be further assistance.

Sincerely,



Jennie Snyder, Ed.D.

Deputy Superintendent, Instructional Services
Sonoma County Office of Education
Phone: (707) 524-2786
Email: jsnyder@scoe.org

***Annual Reporting of Findings
Pursuant to Williams Lawsuit Settlement
Annual Report for Fiscal Year 2018-19***

Findings of Visits and Reviews:

Instructional Materials:

Visitation of twenty-three schools during August and September 2018, validated the presence of sufficient, current, standards based instructional materials in all twenty-three schools visited. Sonoma County districts are to be commended for their efforts to ensure that students have sufficient materials for use in class and at home.

Facilities Maintenance:

There were no findings at the twenty-three sites that qualified as one of the “eight emergency repair situations that poses an emergency or urgent threat to the health or safety of students or staff” as identified under Williams legislation.

Note: To date, emergency funding is still not available but districts have been encouraged to add their names to the list of districts looking for this funding so that when it does become available they are already in the pool.

School Accountability Report Card/Teacher Qualifications

The SARC for all twenty-three schools will be received and reviewed in March 2019. We found 0 teachers have “misassignments” for the (2017-18) school year. Review of credentials will occur in May 2019.

Valenzuela:

Documentation reviews were not conducted during this audit. The SRCS district has opted to exercise flexibility.

Quality of Education Act (QEIA)

There were no school sites monitored during the 2018 Williams Visitation.

Williams Lawsuit Schools 2018-19 Sonoma County
Report to the Sonoma County Board of Education and the Sonoma County Board of Supervisors

District	School	Current	Level	Sufficient instructional Materials	In Good Repair No Extreme Deficiencies	Received SARC's	2017-18 Teacher Misassignments	Used instructional Material Funds Appropriately	Unanswered complaints in relation to the Uniform Complaint Procedure	Base
Bellevue Union School District	Bellevue Elementary	3	Elementary	yes	yes	yes	none	yes	0	2009
Bellevue Union School District	Kawana School	2	Elementary	yes	yes	yes	none	yes	0	2009
Bellevue Union School District	Taylor Mountain Elementary	3	Elementary	yes	yes	yes	none	yes	0	2009
Cloverdale Unified School District	Jefferson Elementary	3	Elementary	yes	yes	yes	none	yes	0	2009
Cotati-Rohnert Park Unified	John Reed Elementary	3	Elementary	yes	yes	yes	none	yes	0	2009
Cotati-Rohnert Park Unified	Thomas Page Elementary	3	Elementary	yes	yes	yes	none	yes	0	2009
Healdsburg Unified	Healdsburg Elem. HES Campus (K-3)	3	Elementary	yes	yes	yes	none	yes	0	2009
Healdsburg Unified	Fitch Mountain Campus (4-5)	3	Elementary	yes	yes	yes	none	yes	0	2009
Petaluma City School District	McKinley School	3	Elementary	yes	yes	yes	none	yes	0	2009
Santa Rosa City School District	Albert F. Biella Elementary	3	Elementary	yes	yes	yes	none	yes	0	2009
Santa Rosa City School District	Brook Hill Elementary	3	Elementary	yes	yes	yes	none	yes	0	2009
Santa Rosa City School District	Comstock Middle School	3	Middle School	yes	yes	yes	none	yes	0	2009
Santa Rosa City School District	Cook (Lawrence) Middle School	1	Middle School	yes	yes	yes	none	yes	0	2009
Santa Rosa City School District	Elsie Allen High	2	High School	yes	yes	yes	none	yes	0	2009
Santa Rosa City School District	Lincoln (Abraham) School	2	Elementary	yes	yes	yes	none	yes	0	2009
Santa Rosa City School District	Monroe (James) School	1	Elementary	yes	yes	yes	none	yes	0	2009
Santa Rosa City School District	Steele Lane School	3	Elementary	yes	yes	yes	none	yes	0	2009
Santa Rosa City School District	Piner High	3	High School	yes	yes	yes	none	yes	0	2009
Sonoma Valley Unified SD	El Verano School	1	Elementary	yes	yes	yes	none	yes	0	2009
Sonoma Valley Unified SD	Flowery School	1	Elementary	yes	yes	yes	none	yes	0	2009
Sonoma Valley Unified SD	Sassarini Elementary	1	Elementary	yes	yes	yes	none	yes	0	2009
Sonoma Valley Unified SD	Altimira Middle	2	Middle School	yes	yes	yes	none	yes	0	2009
Sonoma Valley Unified SD	Dunbar Elementary	2	Elementary	yes	yes	yes	none	yes	0	2009



County of Sonoma Agenda Item Summary Report

Clerk of the Board
575 Administration Drive
Santa Rosa, CA 95403

Agenda Item Number: 15
(This Section for use by Clerk of the Board Only.)

To: Sonoma County Board of Supervisors

Board Agenda Date: November 13, 2018

Vote Requirement: Majority

Department or Agency Name(s): Board of Supervisors

Staff Name and Phone Number:

Supervisor Lynda Hopkins, 565-2241

Supervisorial District(s):

Fifth District

Title: Fifth District Municipal Advisory Councils Update

Recommended Actions:

- a. Approve updates to the Lower Russian River and Sonoma County Coast Municipal Advisory Council Bylaws.
- b. Approve updates to the Sonoma County Coast Municipal Advisory Council map.

Executive Summary:

The Board of Supervisors (Board) approved the Lower Russian River and Sonoma County Coast Municipal Advisory Councils (MAC's) on September 25th, 2018. This item will update the bylaws, and make a correction to the Sonoma County Coast MAC boundaries.

Discussion:

Updates to the Lower Russian River and Sonoma County Coast Bylaws:

The proposed changes to the Bylaws will increase the effectivity of Municipal Advisory Councils in the unique regions of the Fifth District. Changes to the bylaws include:

- An adjustment to the frequency and timing of meetings, from 'monthly' to 'regularly.' All meetings will be posted in accordance with the Brown Act.
- A procedure for Alternates to vote when a Municipal Advisory Council members is absent or recuses themselves from a meeting.
- A change of the parliamentary authority from Robert's Rules of Order to Rosenberg's Rules.

Updates to the Sonoma County Coast Boundaries:

The approved Sonoma County Coast MAC Boundaries contained an error, which placed a small portion of Jenner outside the MAC boundaries. This adjustment will correct the error.

Prior Board Actions:

- Pre-incorporation, the Board established the now-dissolved Windsor Municipal Advisory Council in 1987 (Resolution No. 87-0139).
- The Sonoma County Board of Supervisors and the Sonoma City Council established the Sonoma Valley Citizens Advisory Commission in 1993 (Resolution 93-1552 on 10/12/93; Joint Powers Agreement 98-1281 on 10/6/98; 04-0026 on 1/6/04; 06-0776 on 9/12/06; 14-0086 on 3/11/14).
- The Board created the Dry Creek Valley Citizens Advisory Council in 2012 (Resolution No. 12-0410) and the Mark West Area Citizens Advisory Council in 2016 (Resolution No. 16-0231).
- The Board adopted the Sonoma County Municipal Advisory Council Policies & Procedures on July 18, 2017.
- The Board created the Lower Russian River Advisory Council (Resolution No. 18-0405) and the Sonoma County Coast Municipal Advisory Council on 9/25/2018 (Resolution No. 18-0406).

Strategic Plan Alignment Goal 4: Civic Services and Engagement

Goal 4: Civic Services and Engagement is aimed at engaging and encouraging citizen participation in local government, and aligning public services with community needs and desires. Establishing additional municipal advisory councils will meet this goal by facilitating greater community engagement and interaction with the Board on matters of local concern. Adopting the Recommended Municipal Advisory Council Policies & Procedures will help the Board to effectively and uniformly establish and govern existing and future municipal advisory councils in unincorporated Sonoma County.

Fiscal Summary

Expenditures	FY 18-19 Adopted	FY 19-20 Projected	FY 20-21 Projected
Budgeted Expenses			
Additional Appropriation Requested			
Total Expenditures			
Funding Sources			
General Fund/WA GF			
State/Federal			
Fees/Other			
Use of Fund Balance			
Contingencies			
Total Sources			

Narrative Explanation of Fiscal Impacts:

Staffing Impacts			
Position Title (Payroll Classification)	Monthly Salary Range (A – I Step)	Additions (Number)	Deletions (Number)
Narrative Explanation of Staffing Impacts (If Required):			
Attachments:			
Attachment 1: River Municipal Advisory Council Bylaws Attachment 2: River Municipal Advisory Council Bylaws Redlined Attachment 3: Coast Municipal Advisory Council Bylaws Attachment 4: River Municipal Advisory Council Bylaws Redlined Attachment 5: Coast Municipal Advisory Council Boundaries Update			
Related Items “On File” with the Clerk of the Board:			

**LOWER RUSSIAN RIVER MUNICIPAL ADVISORY COUNCIL
BYLAWS**

Approved by the Sonoma County Board of Supervisors on September 25, 2018
Modified on November 13, 2018

ARTICLE I - NAME

The name of this Municipal Advisory Council shall be the Lower Russian River Municipal Advisory Council (“River MAC”).

ARTICLE II - AUTHORITY AND PURPOSE

Section 1. In order to facilitate community engagement, the River MAC will make recommendations to the Board of Supervisors and other County decision makers on the following Advisory Topics:

- a. Use Permit Applications when referred by the Permit and Resource Management Department
- b. Rezoning applications when referred by the Permit and Resource Management Department
- c. General Plan Amendment Applications when referred by the Permit and Resource Management Department
- d. Prioritization of Transportation and Transit Improvements when requested by the District Supervisor
- e. Health and Human Safety-Net Services when requested by the District Supervisor
- f. Additional Topics Requested by the District Supervisor

Section 2. The duties of the River MAC shall include:

- a. Hold regular open and public meetings;
- b. Study and analyze the Advisory Topics;
- c. Keep the District Supervisor informed of any issues related to Advisory Topics within the community;
- d. Provide advisory recommendations on the Advisory Topics and annual reports to the Board;
- e. Comply with Sonoma County Municipal Advisory Council Policies and Procedures.

ARTICLE III - MEMBERSHIP

Section 1. Membership. The membership of the River MAC shall be nine members.

Requirements for membership include: members must reside within the boundaries of the Municipal Advisory Council, and be at least 18 years of age. There are no requirements for property ownership or citizenship.

The District Supervisor will select members based on the following criteria:

- a. The Fifth District Supervisor will work with the community to identify sub-areas within the MAC Boundaries.
- b. The Fifth District Supervisor will work with the community to evaluate the sub-areas within the River MAC boundaries to determine proper representation on the MAC. This scoping exercise will inform the composition of the MAC for well-rounded representation. The River MAC will have the following representation:
 - Forestville: 2 Representatives, 1 Alternate
 - Hacienda: 1 Representative, 1 Alternate

Rio Nido: 1 Representative, 1 Alternate
Guerneville: 2 Representatives, 1 Alternate
Monte Rio/Villa Grande: 1 Representative, 1 Alternate
Cazadero and Duncans Mills: 1 Representative, 1 Alternate
Pocket Canyon: 1 Representative, 1 Alternate

- c. The Fifth District Supervisor will lead the community in an exercise to nominate representatives and alternates to serve on the MAC using the identified sub-areas as a framework for the composition of the MAC.
- d. The Fifth District Supervisor will consider the community's nominations for appointment to the MAC, and will select final nominations to submit to the Board of Supervisors for appointment.

Section 2. Appointment Authority. The District Supervisor shall submit selected applicants to the Board of Supervisors for appointment. Appointments shall be posted in accordance with the Maddy Act (Government Code section 54970 *et seq.*).

Section 3. Terms. A membership term is a two-year period. The River MAC members may be reappointed. Members may serve a maximum of two terms (four years in total).

Section 4. The Board of Supervisors shall classify the initial members into two classes. Class A shall consist of five members; Class B shall consist of four members. Class A shall have an initial membership term of two years. Class B shall have an initial membership term of three years. Thereafter, each member's term shall be two years. The District Supervisor shall determine which members shall serve the initial three-year term.

Section 5. Attendance. Members are expected to attend all meetings of the River MAC. Absence from two consecutive or three cumulative absences from the River MAC meetings in a twelve-month period may result in removal.

Section 6. Removal. The District Supervisor may, in his or her discretion, recommend removal of a member to the Board of Supervisors. A majority vote by the Board is necessary to remove a member.

Section 7. Vacancies. A vacancy shall exist when a member dies, or submits a written resignation to the District Supervisor, or has been removed as set forth in Section 6. When a vacancy occurs, the District Supervisor will fill the vacancy consistent with membership criteria and submit recommendations to the Board of Supervisors for appointment.

ARTICLE IV- MEETINGS

Section 1. Brown Act. All meetings of the River MAC and, its committees and subcommittees, shall comply with the Brown Act (Government Code section 54950 *et seq.*).

Section 2. Regular Meetings. Regular meetings of the River MAC shall be held regularly at an established date, time and place open to the public. Notice of the meeting time and place should be given to the public and the MAC members at least seventy-two (72) hours before the meeting. The Chair or Vice Chair may cancel any regular meeting by giving written notice of at least seventy-two (72) hours before the regularly scheduled meeting time. This requirement of notification prior to cancellation shall not be waived.

Section 3. Special Meetings. The Chair may call and preside over special meetings. The Chair may call a special meeting by providing notice of the time, place, and agenda to each member and the public at least

(twenty-four) 24 hours before the special meeting. Only items on the agenda of the special meeting may be considered at said special meeting.

Section 4. Quorum. A quorum of the River MAC must be present at any regular or special meeting in order for a decision to be made on any matter. A quorum is defined as a majority of MAC members or voting alternates.

Section 5. Voting. While the River MAC will strive for consensus, every official action taken by the River MAC shall be adopted by a quorum vote. An alternate of the Springs MAC may vote under the following circumstances: 1) If a member of the MAC is absent from a meeting and the alternate replaces the MAC member for the full meeting; 2) If a member of the MAC recuses themselves from an item the alternate may replace the MAC member for the full meeting. If an alternate is sitting for a MAC member and the agenda includes items continued from a prior meeting, the alternate must state on the record that she/he has reviewed the relevant materials for the items on the agenda, including the minutes (if available) from the prior meeting.

Section 6. Abstention. When any member abstains from participation in any matter before the River MAC because of a conflict of interest, that member shall not be counted as present for purposes of determining whether or not there is a quorum. An alternate may fill the MAC member's seat as outlined in sections four and five.

Section 7. Secretary. Administrative support for the River MAC shall be provided by staff identified by the District Supervisor, a voluntary agreement, contract, or other means.

Section 8. Notice. The River MAC meetings will be open and public, with notice of the time and place given to the public and the River MAC members at least seventy-two (72) hours before the time of regular meetings and at least twenty-four (24) hours before special meetings.

Section 9. Public Comment. At each River MAC meeting, members of the public will be given the opportunity to directly address the items on the agenda before being voted on, and on Advisory Topics within the jurisdiction of the River MAC.

ARTICLE V – ADMINSTRATIVE ROLES

Section 1. The River MAC shall have a Chair and Vice Chair. The District Supervisor shall appoint the first Chair and Vice Chair. After that, the MAC will elect the Chair and Vice Chair annually. The Chair and Vice Chair will serve for one (1) calendar years, or until replaced by the District Supervisor.

Section 2. Chair. The Chair shall preside at all meetings of the River MAC and call for special meetings. The Chair shall carry out the duties listed in the Sonoma County Municipal Advisory Council Policies and Procedures.

Section 3. Vice Chair. In the Chair's absence, the Vice Chair shall assume the Chair's responsibilities. The Vice Chair shall carry out the duties listed in the Sonoma County Municipal Advisory Council Policies and Procedures.

ARTICLE VI - COMMITTEES AND SUBCOMMITTEES

Section 1. The River MAC may establish single-purpose committees or subcommittees, consisting of less than a quorum of MAC members, on an as-needed basis by a quorum vote. All committees and subcommittees shall

have a life of one year, with the possibility of extension by the MAC after review. All committees and subcommittees shall comply with the Brown Act.

ARTICLE VII - CONTRACTS

Section 1. The River MAC and/or members thereof shall not have the power or authority to bind the County of Sonoma by any contract or agreement.

ARTICLE VIII – MANDATE FOR COMMUNITY ENGAGEMENT

Section 1. Community engagement is paramount to the success of the River MAC. MAC members will establish a Community Engagement Guide at the start of each calendar year, to be approved by the Fifth District Supervisor.

Section 2. The Community Engagement Guide may include: gatherings in the River MAC sub-areas with neighbors and their MAC representative; town halls; presentations at local schools; and nominating an ex-officio non-voting member student from a local High School.

ARTICLE IX - CONFLICT OF INTEREST/GRIEVANCES

Section 1. Conflict of Interest. The River MAC members will not involve themselves in official River MAC activities that could materially benefit them personally, their business interests, or the interests of organizations that they represent. In a conflict of interest, the member will abstain from voting, and the abstention will be recorded in the minutes.

Section 2. Members and staff will comply with State of California laws regarding conflict of interest for publicly appointed bodies, including the Political Reform Act. The River MAC will implement the procedure for resolving conflicts of interest in the Sonoma County Municipal Advisory Council Recommended Policies and Procedures.

ARTICLE X - AMENDMENTS

Section 1. A recommendation to the Board of Supervisors to amend these bylaws may be made at any regular meeting of the River MAC by a quorum vote of MAC members, provided that copies of the proposed amendments are sent to all members of the River MAC at least ten (10) days prior to the meeting at which such action is taken. The amendment will not be effective until and unless it is approved by majority vote of the Board of Supervisors.

ARTICLE XI – MINUTES

Section 1. There shall be minutes of the River MAC meeting proceedings. The River MAC administrative staff shall be responsible for minutes and will be responsible for the sending of minutes to all River MAC members, the District Supervisor, and members of the public who request them. A record of minutes will be maintained by the River MAC secretary.

ARTICLE XII – RECORDS

Section 1. Records of all River MAC agendas, minutes, meeting materials, records of action, annual reports, and external communications from at least the prior two years shall be maintained by the River MAC Secretary and retained at a location designated by the District Supervisor. These records shall be available for public inspection and copying as required by the Public Records Act (Government Code section 6250 *et seq.*).

ARTICLE XIII - PARLIAMENTARY AUTHORITY

Except as otherwise provided by law, these bylaws, or rules adopted by the Board of Supervisors, Rosenberg's Rules of Order shall be the parliamentary authority of the River MAC.

ARTICLE XIV – LEGAL COMPLIANCE

The River MAC shall comply with the legal requirements of the County of Sonoma, the State of California, and with federal funding sources. Nothing in these bylaws shall be interpreted to be inconsistent with the ordinances of the Sonoma County Board of Supervisors.

ARTICLE XV - EFFECTIVE DATE

These bylaws and future amendments thereto, unless otherwise specified, shall become effective upon adoption by the Sonoma County Board of Supervisors.

Approved by the Sonoma County Board of Supervisors on September 25, 2018.

James Gore, Chair, Sonoma County Board of Supervisors

**LOWER RUSSIAN RIVER MUNICIPAL ADVISORY COUNCIL
BYLAWS**

Approved by the Sonoma County Board of Supervisors on September 25, 2018

Modified on November 13, 2018

ARTICLE I - NAME

The name of this Municipal Advisory Council shall be the Lower Russian River Municipal Advisory Council (“River MAC”).

ARTICLE II - AUTHORITY AND PURPOSE

Section 1. In order to facilitate community engagement, the River MAC will make recommendations to the Board of Supervisors and other County decision makers on the following Advisory Topics:

- a. Use Permit Applications when referred by the Permit and Resource Management Department
- b. Rezoning applications when referred by the Permit and Resource Management Department
- c. General Plan Amendment Applications when referred by the Permit and Resource Management Department
- d. Prioritization of Transportation and Transit Improvements when requested by the District Supervisor
- e. Health and Human Safety-Net Services when requested by the District Supervisor
- f. Additional Topics Requested by the District Supervisor

Section 2. The duties of the River MAC shall include:

- a. Hold regular open and public meetings;
- b. Study and analyze the Advisory Topics;
- c. Keep the District Supervisor informed of any issues related to Advisory Topics within the community;
- d. Provide advisory recommendations on the Advisory Topics and annual reports to the Board;
- e. Comply with Sonoma County Municipal Advisory Council Policies and Procedures.

ARTICLE III - MEMBERSHIP

Section 1. Membership. The membership of the River MAC shall be nine members.

Requirements for membership include: members must reside within the boundaries of the Municipal Advisory Council, and be at least 18 years of age. There are no requirements for property ownership or citizenship.

The District Supervisor will select members based on the following criteria:

- a. The Fifth District Supervisor will work with the community to identify sub-areas within the MAC Boundaries.
- b. The Fifth District Supervisor will work with the community to evaluate the sub-areas within the River MAC boundaries to determine proper representation on the MAC. This scoping exercise will inform the composition of the MAC for well-rounded representation. The River MAC will have the following representation:
Forestville: 2 Representatives, 1 Alternate
Hacienda: 1 Representative, 1 Alternate

Rio Nido: 1 Representative, 1 Alternate
Guerneville: 2 Representatives, 1 Alternate
Monte Rio/Villa Grande: 1 Representative, 1 Alternate
Cazadero and Duncans Mills: 1 Representative, 1 Alternate
Pocket Canyon: 1 Representative, 1 Alternate

- c. The Fifth District Supervisor will lead the community in an exercise to nominate representatives and alternates to serve on the MAC using the identified sub-areas as a framework for the composition of the MAC.
- d. The Fifth District Supervisor will consider the community's nominations for appointment to the MAC, and will select final nominations to submit to the Board of Supervisors for appointment.

Section 2. Appointment Authority. The District Supervisor shall submit selected applicants to the Board of Supervisors for appointment. Appointments shall be posted in accordance with the Maddy Act (Government Code section 54970 *et seq.*).

Section 3. Terms. A membership term is a two-year period. The River MAC members may be reappointed. Members may serve a maximum of two terms (four years in total).

Section 4. The Board of Supervisors shall classify the initial members into two classes. Class A shall consist of five members; Class B shall consist of four members. Class A shall have an initial membership term of two years. Class B shall have an initial membership term of three years. Thereafter, each member's term shall be two years. The District Supervisor shall determine which members shall serve the initial three-year term.

Section 5. Attendance. Members are expected to attend all meetings of the River MAC. Absence from two consecutive or three cumulative absences from the River MAC meetings in a twelve-month period may result in removal.

Section 6. Removal. The District Supervisor may, in his or her discretion, recommend removal of a member to the Board of Supervisors. A majority vote by the Board is necessary to remove a member.

Section 7. Vacancies. A vacancy shall exist when a member dies, or submits a written resignation to the District Supervisor, or has been removed as set forth in Section 6. When a vacancy occurs, the District Supervisor will fill the vacancy consistent with membership criteria and submit recommendations to the Board of Supervisors for appointment.

ARTICLE IV- MEETINGS

Section 1. Brown Act. All meetings of the River MAC and, its committees and subcommittees, shall comply with the Brown Act (Government Code section 54950 *et seq.*).

Section 2. Regular Meetings. Regular meetings of the River MAC shall be held ~~monthly~~regularly at an established date, time and place open to the public. Notice of the meeting time and place should be given to the public and the MAC members at least seventy-two (72) hours before the meeting. The Chair or Vice Chair may cancel any regular meeting by giving written notice of at least seventy-two (72) hours before the regularly scheduled meeting time. This requirement of notification prior to cancellation shall not be waived.

Section 3. Special Meetings. The Chair may call and preside over special meetings. The Chair may call a special meeting by providing notice of the time, place, and agenda to each member and the public at least

(twenty-four) 24 hours before the special meeting. Only items on the agenda of the special meeting may be considered at said special meeting.

Section 4. Quorum. A quorum of the River MAC must be present at any regular or special meeting in order for a decision to be made on any matter. A quorum is defined as a majority of MAC members or voting alternates~~membership~~.

Section 5. Voting. While the River MAC will strive for consensus, every official action taken by the River MAC shall be adopted by a quorum vote. An alternate of the Springs MAC may vote under the following circumstances: 1) If a member of the MAC is absent from a meeting and the alternate replaces the MAC member for the full meeting; 2) If a member of the MAC recuses themselves from an item the alternate may replace the MAC member for the full meeting. If an alternate is sitting for a MAC member and the agenda includes items continued from a prior meeting, the alternate must state on the record that she/he has reviewed the relevant materials for the items on the agenda, including the minutes (if available) from the prior meeting.

Section 6. Abstention. When any member abstains from participation in any matter before the River MAC because of a conflict of interest, that member shall not be counted as present for purposes of determining whether or not there is a quorum. An alternate may fill the MAC member's seat as outlined in sections four and five.

Section 7. Secretary. Administrative support for the River MAC shall be provided by staff identified by the District Supervisor, a voluntary agreement, contract, or other means.

Section 8. Notice. The River MAC meetings will be open and public, with notice of the time and place given to the public and the River MAC members at least seventy-two (72) hours before the time of regular meetings and at least twenty-four (24) hours before special meetings.

Section 9. Public Comment. At each River MAC meeting, members of the public will be given the opportunity to directly address the items on the agenda before being voted on, and on Advisory Topics within the jurisdiction of the River MAC.

ARTICLE V – ADMINSTRATIVE ROLES

Section 1. The River MAC shall have a Chair and Vice Chair. The District Supervisor shall appoint the first Chair and Vice Chair. After that, the MAC will elect the Chair and Vice Chair annually. The Chair and Vice Chair will serve for one (1) calendar years, or until replaced by the District Supervisor.

Section 2. Chair. The Chair shall preside at all meetings of the River MAC and call for special meetings. The Chair shall carry out the duties listed in the Sonoma County Municipal Advisory Council Policies and Procedures.

Section 3. Vice Chair. In the Chair's absence, the Vice Chair shall assume the Chair's responsibilities. The Vice Chair shall carry out the duties listed in the Sonoma County Municipal Advisory Council Policies and Procedures.

ARTICLE VI - COMMITTEES AND SUBCOMMITTEES

Section 1. The River MAC may establish single-purpose committees or subcommittees, consisting of less than a quorum of MAC members, on an as-needed basis by a quorum vote. All committees and subcommittees shall have a life of one year, with the possibility of extension by the MAC after review. All committees and subcommittees shall comply with the Brown Act.

ARTICLE VII - CONTRACTS

Section 1. The River MAC and/or members thereof shall not have the power or authority to bind the County of Sonoma by any contract or agreement.

ARTICLE VIII – MANDATE FOR COMMUNITY ENGAGEMENT

Section 1. Community engagement is paramount to the success of the River MAC. MAC members will establish a Community Engagement Guide at the start of each calendar year, to be approved by the Fifth District Supervisor.

Section 2. The Community Engagement Guide may include: gatherings in the River MAC sub-areas with neighbors and their MAC representative; town halls; presentations at local schools; and nominating an ex-officio non-voting member student from a local High School.

ARTICLE IX - CONFLICT OF INTEREST/GRIEVANCES

Section 1. Conflict of Interest. The River MAC members will not involve themselves in official River MAC activities that could materially benefit them personally, their business interests, or the interests of organizations that they represent. In a conflict of interest, the member will abstain from voting, and the abstention will be recorded in the minutes.

Section 2. Members and staff will comply with State of California laws regarding conflict of interest for publicly appointed bodies, including the Political Reform Act. The River MAC will implement the procedure for resolving conflicts of interest in the Sonoma County Municipal Advisory Council Recommended Policies and Procedures.

ARTICLE X - AMENDMENTS

Section 1. A recommendation to the Board of Supervisors to amend these bylaws may be made at any regular meeting of the River MAC by a quorum vote of MAC members, provided that copies of the proposed amendments are sent to all members of the River MAC at least ten (10) days prior to the meeting at which such action is taken. The amendment will not be effective until and unless it is approved by majority vote of the Board of Supervisors.

ARTICLE XI – MINUTES

Section 1. There shall be minutes of the River MAC meeting proceedings. The River MAC administrative staff shall be responsible for minutes and will be responsible for the sending of minutes to all River MAC members, the District Supervisor, and members of the public who request them. A record of minutes will be maintained by the River MAC secretary.

ARTICLE XII – RECORDS

Section 1. Records of all River MAC agendas, minutes, meeting materials, records of action, annual reports, and external communications from at least the prior two years shall be maintained by the River MAC Secretary and retained at a location designated by the District Supervisor. These records shall be available for public inspection and copying as required by the Public Records Act (Government Code section 6250 *et seq.*).

ARTICLE XIII - PARLIAMENTARY AUTHORITY

Except as otherwise provided by law, these bylaws, or rules adopted by the Board of Supervisors, ~~Robert's~~ Rosenberg's Rules of Order shall be the parliamentary authority of the River MAC.

ARTICLE XIV – LEGAL COMPLIANCE

The River MAC shall comply with the legal requirements of the County of Sonoma, the State of California, and with federal funding sources. Nothing in these bylaws shall be interpreted to be inconsistent with the ordinances of the Sonoma County Board of Supervisors.

ARTICLE XV - EFFECTIVE DATE

These bylaws and future amendments thereto, unless otherwise specified, shall become effective upon adoption by the Sonoma County Board of Supervisors.

Approved by the Sonoma County Board of Supervisors on September 25, 2018.

James Gore, Chair, Sonoma County Board of Supervisors

**SONOMA COUNTY COAST MUNICIPAL ADVISORY COUNCIL
BYLAWS**

Approved by the Sonoma County Board of Supervisors on September 25, 2018
Modified on November 13, 2018

ARTICLE I - NAME

The name of this Municipal Advisory Council shall be the Sonoma County Coast Municipal Advisory Council (“Coast MAC”).

ARTICLE II - AUTHORITY AND PURPOSE

Section 1. In order to facilitate community engagement, the Coast MAC will make recommendations to the Board of Supervisors and other County decision makers on the following Advisory Topics:

- a. Use Permit Applications when referred by the Permit and Resource Management Department
- b. Rezoning applications when referred by the Permit and Resource Management Department
- c. General Plan Amendment Applications when referred by the Permit and Resource Management Department
- d. Prioritization of Transportation and Transit Improvements when requested by the District Supervisor
- e. Health and Human Safety-Net Services when requested by the District Supervisor
- f. Additional Topics Requested by the District Supervisor

Section 2. The duties of the Coast MAC shall include:

- a. Hold regular open and public meetings;
- b. Study and analyze the Advisory Topics;
- c. Keep the District Supervisor informed of any issues related to Advisory Topics within the community;
- d. Provide advisory recommendations on the Advisory Topics and annual reports to the Board;
- e. Comply with Sonoma County Municipal Advisory Council Policies and Procedures.

ARTICLE III - MEMBERSHIP

Section 1. Membership. The membership of the Coast MAC shall be nine members.

Requirements for membership include: members must reside within the boundaries of the Municipal Advisory Council, and be over at least 18 years of age. There are no requirements for property ownership or citizenship.

The District Supervisor will select members based on the following criteria:

- a. The Fifth District Supervisor will work with the community to identify sub-areas within the MAC Boundaries.
- b. The Fifth District Supervisor will work with the community to evaluate the sub-areas within the Coast MAC boundaries to determine proper representation on the MAC. This scoping exercise will inform the composition of the MAC for well-rounded representation. The Coast MAC will have the following representation:

The Sea Ranch/Annapolis: 2 Representatives, 1 Alternate
Timber Cove: 1 Representative, 1 Alternate

Fort Ross/West Cazadero: 1 Representative, 1 Alternate
Jenner: 1 Representative, 1 Alternate
Kashia Band of Pomo Indians: 1 Representative, 1 Alternate
Bodega Bay: 2 Representatives, 1 Alternate
Bodega/Valley Ford: 1 Representative, 1 Alternate

- c. The Fifth District Supervisor will lead the community in an exercise to nominate representatives and alternates to serve on the MAC, using the identified sub-areas as a framework for the composition of the MAC.
- d. The Fifth District Supervisor will consider the community's nominations for appointment to the MAC, and will select final nominations to submit to the Board of Supervisors for appointment.

Section 2. Appointment Authority. The District Supervisor shall submit selected applicants to the Board of Supervisors for appointment. Appointments shall be posted in accordance with the Maddy Act (Government Code section 54970 *et seq.*).

Section 3. Terms. A membership term is a two-year period. The Coast MAC members may be reappointed. Members may serve a maximum of two terms (four years in total).

Section 4. The Board of Supervisors shall classify the initial members into two classes. Class A shall consist of five members; Class B shall consist of four members. Class A shall have an initial membership term of two years. Class B shall have an initial membership term of three years. Thereafter, each member's term shall be two years. The District Supervisor shall determine which members shall serve the initial three-year term.

Section 5. Attendance. Members are expected to attend all meetings of the Coast MAC. Absence from two consecutive or three cumulative absences from the Coast MAC meetings in a twelve-month period may result in removal.

Section 6. Removal. The District Supervisor may, in his or her discretion, recommend removal of a member to the Board of Supervisors. A majority vote by the Board is necessary to remove a member.

Section 7. Vacancies. A vacancy shall exist when a member dies, or submits a written resignation to the District Supervisor, or has been removed as set forth in Section 6. When a vacancy occurs, the District Supervisor will fill the vacancy consistent with membership criteria and submit recommendations to the Board of Supervisors for appointment.

ARTICLE IV- MEETINGS

Section 1. Brown Act. All meetings of the Coast MAC and, its committees and subcommittees, shall comply with the Brown Act (Government Code section 54950 *et seq.*).

Section 2. Regular Meetings. Regular meetings of the Coast MAC shall be held regularly at an established date, time and place open to the public. Notice of the meeting time and place should be given to the public and the MAC members at least seventy-two (72) hours before the meeting. The Chair or Vice Chair may cancel any regular meeting by giving written notice of at least seventy-two (72) hours before the regularly scheduled meeting time. This requirement of notification prior to cancellation shall not be waived.

Section 3. Special Meetings. The Chair may call and preside over special meetings. The Chair may call a special meeting by providing notice of the time, place, and agenda to each member and the public at least

(twenty-four) 24 hours before the special meeting. Only items on the agenda of the special meeting may be considered at said special meeting.

Section 4. Quorum. A quorum of the Coast MAC must be present at any regular or special meeting in order for a decision to be made on any matter. A quorum is defined as a majority of MAC members or voting alternates.

Section 5. Voting. While the Coast MAC will strive for consensus, every official action taken by the Coast MAC shall be adopted by a quorum vote. An alternate of the Springs MAC may vote under the following circumstances: 1) If a member of the MAC is absent from a meeting and the alternate replaces the MAC member for the full meeting; 2) If a member of the MAC recuses themselves from an item the alternate may replace the MAC member for the full meeting. If an alternate is sitting for a MAC member and the agenda includes items continued from a prior meeting, the alternate must state on the record that she/he has reviewed the relevant materials for the items on the agenda, including the minutes (if available) from the prior meeting.

Section 6. Abstention. When any member abstains from participation in any matter before the Coast MAC because of a conflict of interest, that member shall not be counted as present for purposes of determining whether or not there is a quorum. An alternate may fill the MAC member's seat as outlined in sections four and five.

Section 7. Secretary. Administrative support for the Coast MAC shall be provided by staff identified by the District Supervisor, a voluntary agreement, contract, or other means.

Section 8. Notice. The Coast MAC meetings will be open and public, with notice of the time and place given to the public and the Coast MAC members at least seventy-two (72) hours before the time of regular meetings and at least twenty-four (24) hours before special meetings.

Section 9. Public Comment. At each Coast MAC meeting, members of the public will be given the opportunity to directly address the items on the agenda before being voted on, and on Advisory Topics within the jurisdiction of the Coast MAC.

ARTICLE V – ADMINSTRATIVE ROLES

Section 1. The Coast MAC shall have a Chair and Vice Chair. The District Supervisor shall appoint the first Chair and Vice Chair. After that, the MAC will elect the Chair and Vice Chair annually. The Chair and Vice Chair will serve for one (1) calendar years, or until replaced by the District Supervisor.

Section 2. Chair. The Chair shall preside at all meetings of the Coast MAC and call for special meetings. The Chair shall carry out the duties listed in the Sonoma County Municipal Advisory Council Policies and Procedures.

Section 3. Vice Chair. In the Chair's absence, the Vice Chair shall assume the Chair's responsibilities. The Vice Chair shall carry out the duties listed in the Sonoma County Municipal Advisory Council Policies and Procedures.

ARTICLE VI - COMMITTEES AND SUBCOMMITTEES

Section 1. The Coast MAC may establish single-purpose committees or subcommittees, consisting of less than a quorum of MAC members, on an as-needed basis by a quorum vote. All committees and subcommittees shall

have a life of one year, with the possibility of extension by the MAC after review. All committees and subcommittees shall comply with the Brown Act.

ARTICLE VII - CONTRACTS

Section 1. The Coast MAC and/or members thereof shall not have the power or authority to bind the County of Sonoma by any contract or agreement.

ARTICLE VIII – MANDATE FOR COMMUNITY ENGAGEMENT

Section 1. Community engagement is paramount to the success of the Coast MAC. MAC members will establish a Community Engagement Guide at the start of each calendar year, to be approved by the Fifth District Supervisor.

Section 2. The Community Engagement Guide may include: gatherings in the Coast MAC sub-areas with neighbors and their MAC representative; town halls; presentations at local schools; and nominating an ex-officio non-voting member student from a local High School.

ARTICLE IV - CONFLICT OF INTEREST/GRIEVANCES

Section 1. Conflict of Interest. The Coast MAC members will not involve themselves in official Coast MAC activities that could materially benefit them personally, their business interests, or the interests of organizations that they represent. In a conflict of interest, the member will abstain from voting, and the abstention will be recorded in the minutes.

Section 2. Members and staff will comply with State of California laws regarding conflict of interest for publicly appointed bodies, including the Political Reform Act. The Coast MAC will implement the procedure for resolving conflicts of interest in the Sonoma County Municipal Advisory Council Recommended Policies and Procedures.

ARTICLE X - AMENDMENTS

Section 1. A recommendation to the Board of Supervisors to amend these bylaws may be made at any regular meeting of the Coast MAC by a quorum vote of MAC members, provided that copies of the proposed amendments are sent to all members of the Coast MAC at least ten (10) days prior to the meeting at which such action is taken. The amendment will not be effective until and unless it is approved by majority vote of the Board of Supervisors.

ARTICLE XI – MINUTES

Section 1. There shall be minutes of the Coast MAC meeting proceedings. The Coast MAC administrative staff shall be responsible for minutes and will be responsible for the sending of minutes to all Coast MAC members, the District Supervisor, and members of the public who request them. A record of minutes will be maintained by the Coast MAC secretary.

ARTICLE XII – RECORDS

Section 1. Records of all Coast MAC agendas, minutes, meeting materials, records of action, annual reports, and external communications from at least the prior two years shall be maintained by the Coast MAC Secretary

and retained at a location designated by the District Supervisor. These records shall be available for public inspection and copying as required by the Public Records Act (Government Code section 6250 *et seq.*).

ARTICLE XIII - PARLIAMENTARY AUTHORITY

Except as otherwise provided by law, these bylaws, or rules adopted by the Board of Supervisors, Rosenberg's Rules of Order shall be the parliamentary authority of the Coast MAC.

ARTICLE XIV – LEGAL COMPLIANCE

The Coast MAC shall comply with the legal requirements of the County of Sonoma, the State of California, and with federal funding sources. Nothing in these bylaws shall be interpreted to be inconsistent with the ordinances of the Sonoma County Board of Supervisors.

ARTICLE XV - EFFECTIVE DATE

These bylaws and future amendments thereto, unless otherwise specified, shall become effective upon adoption by the Sonoma County Board of Supervisors.

Approved by the Sonoma County Board of Supervisors on September 25, 2018.

James Gore, Chair, Sonoma County Board of Supervisors

**SONOMA COUNTY COAST MUNICIPAL ADVISORY COUNCIL
BYLAWS**

Approved by the Sonoma County Board of Supervisors on September 25, 2018

Modified on November 13, 2018

ARTICLE I - NAME

The name of this Municipal Advisory Council shall be the Sonoma County Coast Municipal Advisory Council (“Coast MAC”).

ARTICLE II - AUTHORITY AND PURPOSE

Section 1. In order to facilitate community engagement, the Coast MAC will make recommendations to the Board of Supervisors and other County decision makers on the following Advisory Topics:

- a. Use Permit Applications when referred by the Permit and Resource Management Department
- b. Rezoning applications when referred by the Permit and Resource Management Department
- c. General Plan Amendment Applications when referred by the Permit and Resource Management Department
- d. Prioritization of Transportation and Transit Improvements when requested by the District Supervisor
- e. Health and Human Safety-Net Services when requested by the District Supervisor
- f. Additional Topics Requested by the District Supervisor

Section 2. The duties of the Coast MAC shall include:

- a. Hold regular open and public meetings;
- b. Study and analyze the Advisory Topics;
- c. Keep the District Supervisor informed of any issues related to Advisory Topics within the community;
- d. Provide advisory recommendations on the Advisory Topics and annual reports to the Board;
- e. Comply with Sonoma County Municipal Advisory Council Policies and Procedures.

ARTICLE III - MEMBERSHIP

Section 1. Membership. The membership of the Coast MAC shall be nine members.

Requirements for membership include: members must reside within the boundaries of the Municipal Advisory Council, and be over at least 18 years of age. There are no requirements for property ownership or citizenship.

The District Supervisor will select members based on the following criteria:

- a. The Fifth District Supervisor will work with the community to identify sub-areas within the MAC Boundaries.
- b. The Fifth District Supervisor will work with the community to evaluate the sub-areas within the Coast MAC boundaries to determine proper representation on the MAC. This scoping exercise will inform the composition of the MAC for well-rounded representation. The Coast MAC will have the following representation:

The Sea Ranch/Annapolis: 2 Representatives, 1 Alternate
Timber Cove: 1 Representative, 1 Alternate

Fort Ross/West Cazadero: 1 Representative, 1 Alternate
Jenner: 1 Representative, 1 Alternate
Kashia Band of Pomo Indians: 1 Representative, 1 Alternate
Bodega Bay: 2 Representatives, 1 Alternate
Bodega/Valley Ford: 1 Representative, 1 Alternate

- c. The Fifth District Supervisor will lead the community in an exercise to nominate representatives and alternates to serve on the MAC, using the identified sub-areas as a framework for the composition of the MAC.
- d. The Fifth District Supervisor will consider the community's nominations for appointment to the MAC, and will select final nominations to submit to the Board of Supervisors for appointment.

Section 2. Appointment Authority. The District Supervisor shall submit selected applicants to the Board of Supervisors for appointment. Appointments shall be posted in accordance with the Maddy Act (Government Code section 54970 *et seq.*).

Section 3. Terms. A membership term is a two-year period. The Coast MAC members may be reappointed. Members may serve a maximum of two terms (four years in total).

Section 4. The Board of Supervisors shall classify the initial members into two classes. Class A shall consist of five members; Class B shall consist of four members. Class A shall have an initial membership term of two years. Class B shall have an initial membership term of three years. Thereafter, each member's term shall be two years. The District Supervisor shall determine which members shall serve the initial three-year term.

Section 5. Attendance. Members are expected to attend all meetings of the Coast MAC. Absence from two consecutive or three cumulative absences from the Coast MAC meetings in a twelve-month period may result in removal.

Section 6. Removal. The District Supervisor may, in his or her discretion, recommend removal of a member to the Board of Supervisors. A majority vote by the Board is necessary to remove a member.

Section 7. Vacancies. A vacancy shall exist when a member dies, or submits a written resignation to the District Supervisor, or has been removed as set forth in Section 6. When a vacancy occurs, the District Supervisor will fill the vacancy consistent with membership criteria and submit recommendations to the Board of Supervisors for appointment.

ARTICLE IV- MEETINGS

Section 1. Brown Act. All meetings of the Coast MAC and, its committees and subcommittees, shall comply with the Brown Act (Government Code section 54950 *et seq.*).

Section 2. Regular Meetings. Regular meetings of the Coast MAC shall be held ~~monthly~~ regularly at an established date, time and place open to the public. Notice of the meeting time and place should be given to the public and the MAC members at least seventy-two (72) hours before the meeting. The Chair or Vice Chair may cancel any regular meeting by giving written notice of at least seventy-two (72) hours before the regularly scheduled meeting time. This requirement of notification prior to cancellation shall not be waived.

Section 3. Special Meetings. The Chair may call and preside over special meetings. The Chair may call a special meeting by providing notice of the time, place, and agenda to each member and the public at least

(twenty-four) 24 hours before the special meeting. Only items on the agenda of the special meeting may be considered at said special meeting.

Section 4. Quorum. A quorum of the Coast MAC must be present at any regular or special meeting in order for a decision to be made on any matter. A quorum is defined as a majority of MAC ~~membership~~members or voting alternates.

Section 5. Voting. While the Coast MAC will strive for consensus, every official action taken by the Coast MAC shall be adopted by a quorum vote. An alternate of the Springs MAC may vote under the following circumstances: 1) If a member of the MAC is absent from a meeting and the alternate replaces the MAC member for the full meeting; 2) If a member of the MAC recuses themselves from an item the alternate may replace the MAC member for the full meeting. If an alternate is sitting for a MAC member and the agenda includes items continued from a prior meeting, the alternate must state on the record that she/he has reviewed the relevant materials for the items on the agenda, including the minutes (if available) from the prior meeting.

Section 6. Abstention. When any member abstains from participation in any matter before the Coast MAC because of a conflict of interest, that member shall not be counted as present for purposes of determining whether or not there is a quorum. An alternate may fill the MAC member's seat as outlined in sections four and five.

Section 7. Secretary. Administrative support for the Coast MAC shall be provided by staff identified by the District Supervisor, a voluntary agreement, contract, or other means.

Section 8. Notice. The Coast MAC meetings will be open and public, with notice of the time and place given to the public and the Coast MAC members at least seventy-two (72) hours before the time of regular meetings and at least twenty-four (24) hours before special meetings.

Section 9. Public Comment. At each Coast MAC meeting, members of the public will be given the opportunity to directly address the items on the agenda before being voted on, and on Advisory Topics within the jurisdiction of the Coast MAC.

ARTICLE V – ADMINSTRATIVE ROLES

Section 1. The Coast MAC shall have a Chair and Vice Chair. The District Supervisor shall appoint the first Chair and Vice Chair. After that, the MAC will elect the Chair and Vice Chair annually. The Chair and Vice Chair will serve for one (1) calendar years, or until replaced by the District Supervisor.

Section 2. Chair. The Chair shall preside at all meetings of the Coast MAC and call for special meetings. The Chair shall carry out the duties listed in the Sonoma County Municipal Advisory Council Policies and Procedures.

Section 3. Vice Chair. In the Chair's absence, the Vice Chair shall assume the Chair's responsibilities. The Vice Chair shall carry out the duties listed in the Sonoma County Municipal Advisory Council Policies and Procedures.

ARTICLE VI - COMMITTEES AND SUBCOMMITTEES

Section 1. The Coast MAC may establish single-purpose committees or subcommittees, consisting of less than a quorum of MAC members, on an as-needed basis by a quorum vote. All committees and subcommittees shall have a life of one year, with the possibility of extension by the MAC after review. All committees and subcommittees shall comply with the Brown Act.

ARTICLE VII - CONTRACTS

Section 1. The Coast MAC and/or members thereof shall not have the power or authority to bind the County of Sonoma by any contract or agreement.

ARTICLE VIII – MANDATE FOR COMMUNITY ENGAGEMENT

Section 1. Community engagement is paramount to the success of the Coast MAC. MAC members will establish a Community Engagement Guide at the start of each calendar year, to be approved by the Fifth District Supervisor.

Section 2. The Community Engagement Guide may include: gatherings in the Coast MAC sub-areas with neighbors and their MAC representative; town halls; presentations at local schools; and nominating an ex-officio non-voting member student from a local High School.

ARTICLE IV - CONFLICT OF INTEREST/GRIEVANCES

Section 1. Conflict of Interest. The Coast MAC members will not involve themselves in official Coast MAC activities that could materially benefit them personally, their business interests, or the interests of organizations that they represent. In a conflict of interest, the member will abstain from voting, and the abstention will be recorded in the minutes.

Section 2. Members and staff will comply with State of California laws regarding conflict of interest for publicly appointed bodies, including the Political Reform Act. The Coast MAC will implement the procedure for resolving conflicts of interest in the Sonoma County Municipal Advisory Council Recommended Policies and Procedures.

ARTICLE X - AMENDMENTS

Section 1. A recommendation to the Board of Supervisors to amend these bylaws may be made at any regular meeting of the Coast MAC by a quorum vote of MAC members, provided that copies of the proposed amendments are sent to all members of the Coast MAC at least ten (10) days prior to the meeting at which such action is taken. The amendment will not be effective until and unless it is approved by majority vote of the Board of Supervisors.

ARTICLE XI – MINUTES

Section 1. There shall be minutes of the Coast MAC meeting proceedings. The Coast MAC administrative staff shall be responsible for minutes and will be responsible for the sending of minutes to all Coast MAC members, the District Supervisor, and members of the public who request them. A record of minutes will be maintained by the Coast MAC secretary.

ARTICLE XII – RECORDS

Section 1. Records of all Coast MAC agendas, minutes, meeting materials, records of action, annual reports, and external communications from at least the prior two years shall be maintained by the Coast MAC Secretary and retained at a location designated by the District Supervisor. These records shall be available for public inspection and copying as required by the Public Records Act (Government Code section 6250 *et seq.*).

ARTICLE XIII - PARLIAMENTARY AUTHORITY

Except as otherwise provided by law, these bylaws, or rules adopted by the Board of Supervisors, ~~Robert's~~ Rosenberg's Rules of Order shall be the parliamentary authority of the Coast MAC.

ARTICLE XIV – LEGAL COMPLIANCE

The Coast MAC shall comply with the legal requirements of the County of Sonoma, the State of California, and with federal funding sources. Nothing in these bylaws shall be interpreted to be inconsistent with the ordinances of the Sonoma County Board of Supervisors.

ARTICLE XV - EFFECTIVE DATE

These bylaws and future amendments thereto, unless otherwise specified, shall become effective upon adoption by the Sonoma County Board of Supervisors.

Approved by the Sonoma County Board of Supervisors on September 25, 2018.

James Gore, Chair, Sonoma County Board of Supervisors

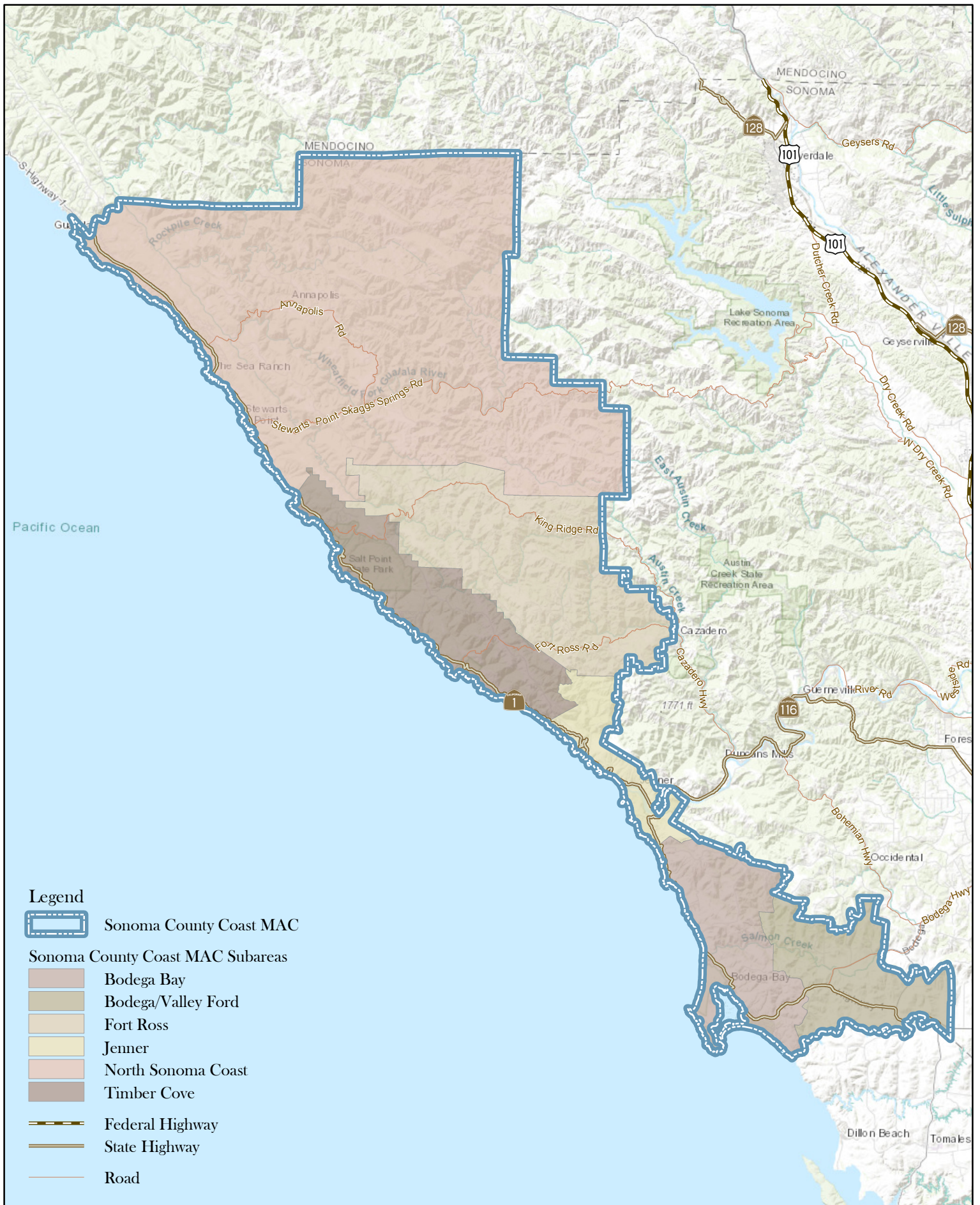



County of Sonoma Agenda Item Summary Report

Clerk of the Board
575 Administration Drive
Santa Rosa, CA 95403

Agenda Item Number: 16
(This Section for use by Clerk of the Board Only.)

To: Board of Supervisors

Board Agenda Date: November 13, 2018

Vote Requirement: Majority

Department or Agency Name(s): Board of Supervisors

Staff Name and Phone Number:

Darin Bartow, 565-2241

Supervisorial District(s):

Countywide

Title: Approve the Minutes of the meetings September 11, 18, 25, October, 2, 9, 16, 23, and 30, 2018 and Approve the Minutes of the meeting October 23, 2018 for the Sonoma Valley County Sanitation District.

Recommended Actions:

Approve the Minutes of the meetings September 11, 18, 25, October, 2, 9, 16, 23, and 30, 2018 and Approve the Minutes of the meeting October 23, 2018 for the Sonoma Valley County Sanitation District.

Executive Summary:

Approve the Minutes of the meetings September 11, 18, 25, October, 2, 9, 16, 23, and 30, 2018 for the following: Agricultural Preservation and Open Space District, Community Development Commission, Occidental County Sanitation District, Russian River County Sanitation District, South Park County Sanitation District, Sonoma County Water Agency, and Board of Supervisors; and Approve the Minutes of the meeting October 23, 2018 for the Sonoma Valley County Sanitation District.

Discussion:

None

Prior Board Actions:

May 22, 2018; August 7, 2018; August 14, 2018; September 11, 2018

Strategic Plan Alignment Goal 4: Civic Services and Engagement

Fiscal Summary			
Expenditures	FY 18-19 Adopted	FY 19-20 Projected	FY 20-21 Projected
Budgeted Expenses			
Additional Appropriation Requested			
Total Expenditures			
Funding Sources			
General Fund/WA GF			
State/Federal			
Fees/Other			
Use of Fund Balance			
Contingencies			
Total Sources			
Narrative Explanation of Fiscal Impacts:			
Staffing Impacts			
Position Title (Payroll Classification)	Monthly Salary Range (A – I Step)	Additions (Number)	Deletions (Number)
Narrative Explanation of Staffing Impacts (If Required):			
Attachments:			
Minutes of the September 11, 18, 25, October, 2, 9, 16, 23, and 30, 2018 meetings.			
Related Items “On File” with the Clerk of the Board:			

ACTION SUMMARY
BOARD OF SUPERVISORS
SONOMA COUNTY
575 ADMINISTRATION DRIVE, ROOM 102A
SANTA ROSA, CA 95403

TUESDAY

SEPTEMBER 11, 2018

8:30 A.M.

Susan Gorin	First District	Sheryl Bratton	County Administrator
David Rabbitt	Second District	Bruce Goldstein	County Counsel
Shirlee Zane	Third District		
James Gore	Fourth District		
Lynda Hopkins	Fifth District		

8:31 A.M. CALL TO ORDER

Supervisors Present: Susan Gorin, David Rabbitt, Shirlee Zane, James Gore, Lynda Hopkins

Staff Present: Sheryl Bratton, County Administrator and Bruce Goldstein, County Counsel

PLEDGE OF ALLEGIANCE

I. [APPROVAL OF THE AGENDA \(Items may be added or withdrawn from the agenda consistent with State law\)](#)

Supervisor Gore announced that Item 16 and 40 have been removed from the consent calendar by addendum.

Supervisor Gore announced that he has formed a Board Ad Hoc Committee consisting of Supervisor Hopkins and himself for issues surrounding the relicensing of the Potter Valley Hydroelectric Project.

Supervisor Gore pulled consent items 31 and 33 to the regular calendar.

Board action: Approved as Amended
UNANIMOUS VOTE

II. [PUBLIC COMMENT ON CLOSED SESSION ITEMS](#)

8:35 A.M. Public comment on closed session opened

Public Speakers:
Duane De Witt
Michael Hilbur
Joel Evans-Fudem
Hayley McAllister
Billy Harville
Cecilia Castro-Garcia

8:47 A.M. Public Comment closed session Closed

8:48 A.M. The Board went into Recess.

9:22 A.M. The Board Reconvened.

III. [CLOSED SESSION CALENDAR](#)

9:22 A.M. The Chair deferred the Closed Session report until after item 53.

2:22 P.M. County Counsel Bruce Goldstein reported on Closed Session Items 1 through 6.

1. [The Board of Supervisors will consider the following in closed session: Conference with Legal Counsel – Existing Litigation – Friends of Chanate v. County of Sonoma; Sonoma County Superior Court Case No. SCV-261103 \(Government Code Section 54956.9\(d\)\(1\).\)](#)

The Board decided that no appeal was to be filed.
UNANIMOUS VOTE

2. [The Board of Supervisors will consider the following in closed session: Conference with Legal Counsel - Existing Litigation: Sonoma County Association of Retired Employees \(SCARE\) v. Sonoma County, U.S. District Court Case Number CV-09-4432 CW \(Government Code Â§54956.9\(d\)\(1\)\).](#)

No reportable action. Direction was given to counsel and staff.

3. [The Board of Supervisors will consider the following in closed session: Conference with Legal Counsel Existing Litigation Anthony King vs. County of Sonoma Workers Compensation Appeals Board Nos. ADJ9725477 & ADJ9775393](#)

The Board approved a Workers' Compensation settlement agreement paying Ms. Leuenberger-Fell \$80,000 less permanent disability advances.
UNANIMOUS VOTE

4. [The Board of Supervisors will consider the following in closed session: Conference with Legal Counsel Existing Litigation/Anticipated Litigation. Potential initiation of litigation pursuant to Government Code section 54956.9\(d\)\(1\) and 54956.9\(d\)\(4\). Jenae Leuenberger-Fell vs. County of Sonoma; Workers Compensation Appeals Board No.Unassigned](#)

The Board approved a Workers' Compensation settlement agreement paying Ms. Leuenberger-Fell \$80,000 less permanent disability advances.
UNANIMOUS VOTE

5. [The Board of Supervisors will consider the following in closed session: Conference with Legal Counsel Existing Litigation Catherine Williams v. County of Sonoma- Sonoma County Superior Court Case No. SCV 261355 \(Government Code Section 54956.9\(d\)\(1\).\)](#)

No reportable action. Direction was given to counsel and staff.

6. [The Board of Supervisors, the Board of Directors of the Water Agency, the Board Commissioners of the Community Development Commission, and the Board of Directors of The Agricultural Preservation and Open Space District will consider the following in closed session: Conference with Labor Negotiators: Christina Cramer/Carol Allen, County of Sonoma, and Rick Bolanos/Heather Coffman, Liebert Cassidy & Whitmore. Employee Organizations: All. Unrepresented employees: All, including retired employees. \(Government Code section 54957.6\).](#)

This item was withdrawn.

7. [RECONVENE FROM CLOSED SESSION](#)

This item was taken out of order.

2:22 P.M.

Supervisors Present: Susan Gorin, David Rabbitt, Shirlee Zane, Lynda Hopkins

Supervisors Absent: James Gore

Staff Present: Sheryl Bratton, County Administrator and Bruce Goldstein, County Counsel

8. [REPORT ON CLOSED SESSION](#)

9:22 A.M. The Chair deferred the Closed Session report until after item 53.

2:22 P.M. County Counsel Bruce Goldstein reported on Closed Session Items 1 through 6.

IV. [9:22 A.M - CONSENT CALENDAR](#)

9:36 A.M. Public comment opened

Speakers:

Duane De Witt
John Nichols
Briana Pawka
Anita Layfollette
Thomas Ells

9:48 A.M. Public comment closed

[HUMAN RESOURCES/COUNTY ADMINISTRATOR/BOARD OF SUPERVISORS](#)

AND

[AGRICULTURAL PRESERVATION AND OPEN SPACE DISTRICT/
SONOMA COUNTY WATER AGENCY](#)

(Directors: Gorin, Rabbitt, Zane, Gore, Hopkins)

AND

[COMMUNITY DEVELOPMENT COMMISSION](#)

(Commissioners: Gorin, Rabbitt, Zane, Gore, Hopkins)

9. [Recovery Leave Time for Employee Fire Victims: Approve Concurrent Resolution to Provide 40 Hours of Fire Recovery Leave to County Employees Who Lost Their Primary Residence in the October 2017 Sonoma Complex Fires, and also extends the existing County Employee Disaster Leave Program for an additional 12 months after the local emergency declaration ends.](#)

Board action: Approved as Recommended

UNANIMOUS VOTE

Approved by Resolution 18-0349

[SONOMA COUNTY WATER AGENCY/](#)

[OCCIDENTAL COUNTY SANITATION DISTRICT/RUSSIAN RIVER SANITATION DISTRICT](#)

(Directors: Gorin, Rabbitt, Zane, Gore, Hopkins)

AND

[SONOMA VALLEY SANITATION DISTRICT](#)

(Directors: Gorin, Gore, Mayor Agrimonti)

10. [Biotoxicity Monitoring and Related Services: As part of an ongoing effort to comply with environmental regulations and the Environmental Protection Agency and state required permits, and to keep the local water and wastewater free of toxins and safe for the public and the environment:](#)
- A) [Authorize Sonoma County Water Agency's General Manager, acting on behalf of Sonoma County Water Agency; and Occidental, Russian River, and Sonoma Valley County Sanitation Districts, to execute an agreement with AQUA-Science, Inc. for biotoxicity monitoring and related services from July 1, 2018, to June 30, 2021, in an amount not to exceed \\$540,000 \(up to \\$180,000 per year for three years\); and](#)
- B) [Authorize Sonoma County Water Agency's General Manager, acting on behalf of Occidental, Russian River, and Sonoma Valley County Sanitation Districts, to execute an agreement with Pacific EcoRisk, Inc. for biotoxicity monitoring, peer review testing and related services for an amount not to exceed \\$300,000 \(up to \\$100,000 per year for three years\), from July 1, 2018, to June 30, 2021.](#)

Board action: Approved as Recommended

UNANIMOUS VOTE

**SONOMA COUNTY WATER AGENCY/
SOUTH PARK COUNTY SANITATION DISTRICT**

(Directors: Gorin, Rabbitt, Zane, Gore, Hopkins)

11. South Park County Sanitation District Collection System Replacement East Robles Avenue, Brooks Avenue, and Delores Lane Budget Resolution: Adopt a resolution authorizing adjustments to the Board Adopted Budget for Fiscal Year 2018-2019 for the South Park County Sanitation District Construction Fund in the amount of \$1,134,125 for the Collection System Replacement East Robles Avenue, Brooks Avenue, and Delores Lane Construction Project. (Third District)(4/5th Vote Required)

Board action: Approved as Recommended
UNANIMOUS VOTE
Approved by Resolution 18-0350

SONOMA COUNTY WATER AGENCY

(Directors: Gorin, Rabbitt, Zane, Gore, Hopkins)

AND

HUMAN SERVICES

12. Sonoma County Youth Ecology Corps and Career Pathway Program: Concurrent Action: Authorize Sonoma County Water Agency's General Manager and the County's Director of the Human Services Department to execute a cooperative agreement for partial funding of the Sonoma County Youth Ecology Corps and Career Pathway Program in the not-to-exceed amount of \$1,275,000; the agreement covers services rendered from July 1, 2018, to June 30, 2021. The Sonoma County Youth Ecology Corps provides youth and adults with meaningful, paid work experience, environmental education, and the opportunity to explore careers and develop work-readiness skills.

Board action: Approved as Recommended
UNANIMOUS VOTE

SONOMA COUNTY WATER AGENCY

(Directors: Gorin, Rabbitt, Zane, Gore, Hopkins)

13. Russian River Habitat Focus Area Grant:

- A) Authorize the Sonoma County Water Agency's General Manager or designee to accept FY 2018-2019 grant funds from the National Oceanic and Atmospheric Administration (\$155,000) for projects to improve and monitor fish habitat in the Russian River and its tributaries.
- B) Authorize the Sonoma County Water Agency's General Manager or designee to execute an agreement in a form approved by County Counsel with Resource Management Associates, Inc. to provide water quality modeling of the Russian River system (not to exceed \$230,000; agreement expires Dec. 31, 2020).

Board action: Approved as Recommended
UNANIMOUS VOTE

14. Russian River Watershed Program: Authorize Sonoma County Water Agency's General Manager to execute the First Amended Agreement for Funding of Russian River Watershed Program with Gold Ridge Resource Conservation District to improve watershed health through monitoring and restoration projects increasing the amount by \$27,000, expanding the scope of work to include groundwater sustainability planning and reporting, for a new not-to-exceed agreement total of \$87,000 and no change to end date of August 31, 2019.

Board action: Approved as Recommended
UNANIMOUS VOTE

15. Water Quality Computer Modeling for Ralphine Tanks: Authorize Sonoma County Water Agency's General Manager to execute an agreement with Schaaf and Wheeler Consulting Engineers for Ralphine water storage tank water quality modeling services through December 31, 2019 in the not-to-exceed amount of \$137,980. The modeling services will help Sonoma Water evaluate proposed design changes to the storage tanks in an effort to improve water quality, increase water storage, and improve seismic resiliency. (First District)

Board action: Approved as Recommended
UNANIMOUS VOTE

AGRICULTURAL PRESERVATION AND OPEN SPACE DISTRICT

(Directors: Gorin, Rabbitt, Zane, Gore, Hopkins)

16. [Graton Community Park Matching Grant Project: Adopt a resolution of the Board of Directors of the Sonoma County Agricultural Preservation and Open Space District making certain findings, approving a grant of up to \\$103,124 for the Graton Community Park Matching Grant Project, authorizing the acquisition of a conservation easement and recreation covenant, and authorizing and directing the General Manager to take all other actions necessary to establish a conservation easement, recreation covenant and grant agreement. \(Fifth District\)](#)

This item was removed.

17. [River Lane Matching Grant Project: Adopt a resolution of the Board of Directors of the Sonoma County Agricultural Preservation and Open Space District making certain findings, approving a grant of up to \\$35,000 for the River Lane Matching Grant Project, authorizing the acquisition of a conservation easement and recreation covenant, and authorizing and directing the General Manager to take all other actions necessary to establish a conservation easement, recreation covenant and grant agreement. \(Fifth District\)](#)

Board action: Approved as Recommended
UNANIMOUS VOTE
Approved by Resolution 18-0352

AUDITOR- CONTROLLER-TREASURER-TAX COLLECTOR

18. [Quarterly Treasury Financial Report: Review and accept the quarterly Treasury Financial Report for the period of April 1 through June 31, 2018.](#)

Board action: Approved as Recommended
UNANIMOUS VOTE

19. [Annual Financing for the Alternative Method of Property Tax Allocation \(Teeter Plan\) for delinquent property taxes for the fiscal year ending 2017-18: Approve resolution authorizing the \\$7,763,800 annual financing used to advance delinquent taxes to taxing jurisdictions in fiscal year 2017-18 and renew the issuance of \\$7,010,500 in prior delinquent tax anticipation notes as authorized by the Alternative Method of Property Tax Allocation.](#)

Board action: Approved as Recommended
UNANIMOUS VOTE
Approved by Resolution 18-0353

20. [Fiscal Year 2018-19 Secured Property Tax Rates:](#)

- A) Adopt Concurrent Resolution of the Board of Supervisors of the County of Sonoma and the Board of Directors of the Sonoma County Water Agency, setting the Fiscal Year 2018-19 secured property tax rates including tax rates for all debt service funds within their jurisdictions.
- B) [Adopt Resolution of the Board of Supervisors, County of Sonoma, setting the Fiscal Year 2018-19 unitary, operating non-unitary, and railroad unitary tax rate for voter approved indebtedness.](#)

Board action: Approved as Recommended
UNANIMOUS VOTE
Approved by Resolution 18-0354 and 18-0355

BOARD OF SUPERVISORS

21. [Board of Supervisors Meeting Minutes: Approve the Minutes of the meetings August 7, 14, and 28, 2018.](#)

Board action: Approved as Recommended
UNANIMOUS VOTE

COUNTY ADMINISTRATOR

22. Board of Supervisors Response to the 2017-2018 Civil Grand Jury Report:
- A) Approve the Board of Supervisors response to the 2017-2018 Civil Grand Jury Report recommendations, and direct staff to formally transmit Sonoma County's complete set of responses to the 2017-2018 Civil Grand Jury Report findings and recommendations.
 - B) Approve a resolution expressing support for the revisions to the State of California Fire Mutual Aid as cited by the California Fire Chiefs Association.

Board action: Approved as Recommended
UNANIMOUS VOTE
Approved by Resolution 18-0356

23. Recovery Update: Receive an update on the status of recovery operations, planning, seeking of funding opportunities, community engagement and status of recovery plan.

Board action: Approved as Recommended
UNANIMOUS VOTE

CLERK-RECORDER-ASSESSOR

24. Consolidation of November 6, 2018, Consolidation General Election: Adopt the resolution authorizing consolidation of all jurisdictions that have submitted a request for consolidation, as required by Elections Code Â§10400, and have measures to be placed before the voters or sufficient nominees to require elections to be held on November 6, 2018.

Board action: Approved as Recommended
UNANIMOUS VOTE
Approved by Resolution 18-0357

DISTRICT ATTORNEY'S OFFICE

25. Alcohol and Drug Impaired Vertical Prosecution Program Renewal: Adopt a resolution authorizing the District Attorney to sign a contract with the State of California, Office of Traffic Safety to continue a specialized DUI Vertical Prosecution program and accept \$234,032 in grant funding for the term October 1, 2018 to September 30, 2019. The objective of this grant is to reduce the incident and injuries of alcohol-involved and drug-involved collisions, injuries and deaths.

Board action: Approved as Recommended
UNANIMOUS VOTE
Approved by Resolution 18-0358

GENERAL SERVICES/HEALTH SERVICES

26. Lease Renewal for the Department of Health Services at 625 5th Street, Santa Rosa:
- A) Authorize the Board Clerk to publish a notice declaring the intent of the Board of Supervisors to execute a lease renewal with Sonoma Commercial Investors L.P. as Landlord for 38,473 rentable square feet of office space at 625 5th Street, Santa Rosa, for a term of 6 years; rental payment of \$72,137 per month for the first three-years (\$865,644 per year), and tenant improvements completed by the landlord, in support of saving the Department of Health Services Public Health Division an estimated \$1,554,935 over the 6 year lease term.

- B) Authorize the General Services Director to execute a letter agreement whereby the landlord will prepare architectural construction drawings and apply for building permits prior to potential execution of the proposed lease renewal and approval by the Board.

Board action: Approved as Recommended
UNANIMOUS VOTE

27. License Agreement for Women's Recovery Services/A Unique Place:

- A) Authorize the General Services Director to execute a license agreement with the Women's Recovery Services/A Unique Place, for use of a single-family dwelling located in west Santa Rosa, for a term of two (2) years through June 30, 2020; and to execute future amendments and associated documents.
- B) Make findings as required by Government Code Section 26227, that the proposed license agreement is necessary to meet the social needs of the population of the County, and that the County does not need the Premises during the term of the license agreements.

Board action: Approved as Recommended
UNANIMOUS VOTE

HEALTH SERVICES

28. Crisis Counseling Program Grant Kaiser Foundation Hospital Fund:

- A) Authorize the Director of Health Services to execute a grant agreement with Kaiser Foundation Hospital Fund for Community Benefit Programs at the East Bay Community Foundation to accept \$1,000,000 in revenue to support the Crisis Counseling Program for the period January 1, 2019 through September 30, 2019.
- B) Authorize the Director of Health Services to execute amendments to agreements with four partner organizations to support an extension of Crisis Counseling Assistance and Training Program services in Sonoma County, increasing each contract by \$243,269 resulting in a new total not-to-exceed amount of \$1,217,435 per contract, for a new combined total amount of \$4,869,740 through June 30, 2019.
- C) Adopt a resolution adjusting the fiscal year 2018-2019 final budget by increasing revenues and expenditures in the Department of Health Services by \$1,000,000 to reflect receipt of Kaiser Foundation Hospital Fund for Community Benefit Programs at the East Bay Community Foundation grant revenue and associated expenditures. (4/5th vote required) (4/5th Vote Required)

Board action: Approved as Recommended
UNANIMOUS VOTE
Approved by Resolution 18-0359

HUMAN RESOURCES

29. Exemption of Director, Emergency Management from Civil Service Ordinance:

- A) Adopt a resolution reading the title of and waiving further reading of the proposed ordinance amending the Sonoma County Code to exempt of Director of Emergency Management from the Civil Service system.
- B) Adopt the ordinance. (Second Reading - Ready for Adoption)

Board Action: Approved as Recommended
UNANIMOUS VOTE

SHERIFF'S OFFICE

30. [Agreement for Supplemental Law Enforcement Services with Sonoma Raceway: Authorize the Sheriff to execute the Supplemental Law Enforcement Services Agreement with Sonoma Raceway for its Indy Racing League \(IRL\) event from September 14, 2018 through September 16, 2018 for the revenue in the amount of \\$53,172 to ensure the safety of Sonoma County citizens and visitors during a major outdoor event. \(Second District\)](#)

Board action: Approved as Recommended
UNANIMOUS VOTE

PERMIT AND RESOURCE MANAGEMENT

31. [Agricultural Preserve expansion and new Land Conservation Act Contract, AGP16-0009 Rombauer Vineyards: Adopt a Resolution to \(a\) expand an existing Agricultural Preserve by 242.4 acres, and \(b\) authorize the Chairman of the Board of Supervisors to execute a new Prime Land Conservation Act Contract for the subject parcel located at 3555 Napa Rd, Sonoma; File No. AGP16-0009; Supervisorial District 1. \(First District\)](#)

Item 31 was pulled to the regular calendar.

12:18 P.M. This item was taken out of order.

Presenters:

Traci Tesconi, Planner, Permit and Resource Management Department
Derik Michaelson, Planner, Permit and Resource Management Department

12:19 P.M Public Hearing Opened

Public Speakers:
None

12:19 P.M. Public Hearing Closed

Board action: Approved as Recommended
UNANIMOUS VOTE
Approved by Resolution 18-0361

32. [Land Conservation Act Contract Replacement; Timothy and Denyse Browne: Adopt a resolution to approve the requested Prime Land Conservation Act contract replacement and attached Land Conservation Plan for a 29.92 acre property located at 2364 Geysers Rd., Geyserville; APNs 131-030-027 and -028; Permit Sonoma File No. AGP16-0020; Supervisorial District 4. \(Fourth District\)](#)

Board action: Approved as Recommended
UNANIMOUS VOTE
Approved by Resolution 18-0362

33. [Agricultural Preserve expansion and new Land Conservation Act Contract, AGP16-0006 Tresch Farms: Adopt a Resolution to \(a\) expand an existing Agricultural Preserve by 60 acres, and \(b\) authorize the Chairman of the Board of Supervisors to execute a new Non-Prime Land Conservation Act Contract for the subject parcel at 13950 Valley Ford Rd, Petaluma, CA; File No. AGP16-0006; Supervisorial District 5. \(Fifth District\)](#)

Item 33 was pulled to the regular calendar

12:19 P.M. This item was taken out of order.

Presenters:

Traci Tesconi, Planner, Permit and Resource Management Department
Derik Michaelson, Planner, Permit and Resource Management Department

12:20 A.M. Public Hearing Opened

Public Speakers:
None

12:20 P.M. Public Hearing Closed

Board action: Approved as Recommended
UNANIMOUS VOTE
Approved by Resolution 18-0363

TRANSPORTATION AND PUBLIC WORKS

34. [Solid Waste Collection Franchise Agreement Sonoma Garbage Collectors Second Amendment: Authorize the Chair to execute Amendment No. 2 to the Solid Waste Collection Franchise Agreement By and Between the County of Sonoma and Sonoma Garbage Collectors \(SGC\) to: \(a\) provide a residential 20-gallon garbage can service option; and \(b\) change the audit period from Company's preceding fiscal year to County's preceding fiscal year.](#)

Board action: Approved as Recommended
UNANIMOUS VOTE

PRESENTATIONS/GOLD RESOLUTIONS

PRESENTATIONS AT THE BOARD MEETING

(Gold resolutions will be presented at 11:15 A.M.)

35. [Approve Gold Resolution recognizing Bill Nordskog for his many years of service supporting Sonoma County adult and youth workforce programs. \(Human Services\)](#)

Board action: Approved as Recommended
UNANIMOUS VOTE
Approved by Resolution 18-0364

36. [Adopt a Gold Resolution acknowledging the importance of breastfeeding awareness and support. \(Health Services\)](#)

Board action: Approved as Recommended
UNANIMOUS VOTE
Approved by Resolution 18-0365

37. [Adopt a Gold resolution proclaiming the week of September 9 through September 15, 2018 as Suicide Prevention Week in Sonoma County. \(Health Services\)](#)

Board action: Approved as Recommended
UNANIMOUS VOTE
Approved by Resolution 18-0366

PRESENTATION ON A DIFFERENT DATE

38. [Adopt a Gold Resolution congratulating Sonoma County Philharmonic on its anniversary marking 20 years of breathtaking classical music performances. \(Fourth District\)](#)

Board action: Approved as Recommended
UNANIMOUS VOTE
Approved by Resolution 18-0367

39. [Adopt a Gold resolution proclaiming September 22-28, 2018, as Falls Prevention Awareness Week in Sonoma County. \(Human Services\)](#)

Board action: Approved as Recommended
UNANIMOUS VOTE
Approved by Resolution 18-0368

APPOINTMENTS/REAPPOINTMENTS

40. [Approve the Reappointment of Gary Saperstein to the Sonoma County Tourism Board, effective July 1, 2018 and expiring on July 1, 2020. \(First District\)](#)

This item was removed.

41. [Approve the Reappointment of James Luchini to the Sonoma County Tourism Board for a two year term ending June 30, 2020. \(Fourth District\)](#)

Board action: Approved as Recommended
UNANIMOUS VOTE

42. [Approve the Appointment of Jenny Helman to the Sonoma County Area Agency on Aging for a two year term beginning September 11, 2018 and expiring September 11, 2020. \(Fourth District\)](#)

Board action: Approved as Recommended
UNANIMOUS VOTE

43. [Approve the Reappointment of William Severi as a general member and Matt Eshoo and Ross Liscum as alternate members of the Assessment Appeals Board for a term of three years beginning on September 3, 2018 and ending on September 3, 2021. \(Countywide\)](#)

Board action: Approved as Recommended
UNANIMOUS VOTE

44. [General District Election Appointments: Adopt a resolution appointing nominees to the office of director of their respective districts for the following districts: Coast Life Support District, Forestville Fire Protection District, Geyserville Fire Protection District, Gold Ridge Fire Protection District, Kenwood Fire Protection District, Monte Rio Fire Protection District, North Sonoma Coast Fire Protection District, Rancho Adobe Fire Protection District, Rincon Valley Fire Protection District, Russian River Fire Protection District, Timber Cove Fire Protection District, Valley of the Moon Fire Protection District, Windsor Fire Protection District, Cloverdale Health Care District, North Sonoma County Health Care District, Petaluma Health Care District, Sweetwater Springs Water District, Valley of the Moon Water District. \(Clerk Recorder Assessor\)](#)

Board action: Approved as Recommended
UNANIMOUS VOTE
Approved by Resolution 18-0369

45. [Approve the re-appointment of Brandy Evans, Steve Herron, Scott Kincaid, and George Steffensen to the Sonoma County Workforce Investment Board for a two-year term beginning September 11, 2018 and ending September 11, 2020. \(Human Services\)](#)

Board action: Approved as Recommended
UNANIMOUS VOTE

9:36 AM Public Comment Opened

Public Speakers:

Duane DeWitt

John Nichols

Briana Pawka

Anita Layfollette

Thomas Ells

9:48 A.M. Public Comment Closed

- V. [REGULAR CALENDAR](#)

**COUNTY ADMINISTRATOR/HUMAN RESOURCES/AUDITOR- CONTROLLER-TREASURER-TAX
COLLECTOR /BOARD OF SUPERVISORS**

AND

**AGRICULTURAL PRESERVATION AND OPEN SPACE DISTRICT/
SONOMA COUNTY WATER AGENCY**

(Directors: Gorin, Rabbitt, Zane, Gore, Hopkins)

AND

COMMUNITY DEVELOPMENT COMMISSION

(Commissioners: Gorin, Rabbitt, Zane, Gore, Hopkins)

46. [Pension Ad-Hoc Report: Approve Pension Reform Ad-hoc Recommendations intended to reduce Unfunded Actuarial Accrued Liability \(UAAL\).](#)

9:49 A.M.

Presenters:

Supervisor Rabbitt, District 2

Supervisor Zane, District 3

Christina Rivera, Assistant County Administrator

Debbie Latham, Deputy County Counsel

10:51 A.M. Public Comment Opened

Public Speakers:

Andre Bercut

Liz Fiekowsky

Congresswoman Lynn Woolsey

Bob Hansen

10:59 A.M. Public Comment Closed

Board action: Approved as Recommended

UNANIMOUS VOTE

47. [Other Post-Employment Benefits \(OPEB\):](#)

A) [Accept Actuarial Valuation of Other Post-Employment Benefits \(OPEB\) as of June 30, 2017 pursuant to updated Financial Reporting and Accounting Requirements from the Governmental Accounting Standards Board \(GASB\) Statements 74 and 75.](#)

B) [Direct Staff to review previous strategies and develop recommendations for future options to reduce OPEB Unfunded Liability.](#)

11:13 A.M.

Presenters:

Christina Cramer, Director, Human Resources

Erick Roeser, Auditor Controller Treasurer Tax Collector

Marcia Chadbourne, Risk Manager, Human Resources

11:44 A.M. Public Comment Opened

Public Speakers:

Bill Robotka

11:45 A.M. Public Comment Closed

Board action: Informational Only

PERMIT AND RESOURCE MANAGEMENT

48. [10:50 A.M. - Amendment to Chapter 26A of the Sonoma County Code \(Mining Ordinance\) to clarify setbacks to critical habitat: Hold a public hearing and adopt the attached ordinance amending Chapter 26A \(Mining Code\) to clarify that setbacks to critical habitat do not retroactively apply to quarry sites that were approved prior to the General Plan designation of critical habitat in 2012.](#)

12:21 P.M.

Presenters:

Blake Hillegas, Supervising Planner, Permit and Resource Management Department

12:26 P.M. Public Hearing Opened

Public Speakers:

None

12:26 P.M. Public Hearing Closed

Board action: Approved as Recommended

UNANIMOUS VOTE

Approved by Ordinance 6244

TRANSPORTATION AND PUBLIC WORKS

49. [11:00 A.M. - Jenner Water District Financing: Hold a public hearing on the annual written report for County Service Area No. 41 Jenner Zone of Benefit and adopt the resolution ordering the annual water charge to be collected on the County of Sonoma tax roll for the total amount of \\$65,458 for Fiscal Year 2018-2019. \(Fifth District\)\(4/5th Vote Required\)](#)

12:27 P.M.

Presenters:

Trish Pisenti, Interim Deputy Director, Transportation and Public Works

Adrian Diaz, Department Analyst, Transportation and Public Works

12:28 A.M. Public Hearing Opened

Public Speakers:

None

12:28 P.M. Public Hearing Closed

Board action: Approved as Recommended

UNANIMOUS VOTE

Approved by Resolution 18-0370

50. [11:05 A.M. - Salmon Creek Water District Financing: Hold a public hearing on the annual written report for County Service Area No. 41 Salmon Creek Water System and adopt the resolution ordering the annual water charge for the debt service and the \\$30 annual charge for water availability to be collected on the County of Sonoma tax roll for the total amount of \\$45,084 for Fiscal Year 2018-19. \(Fifth District\)\(4/5th Vote Required\)](#)

12:28 P.M.

Presenters:

Trish Pisenti, Interim Deputy Director, Transportation and Public Works

Adrian Diaz, Department Analyst, Transportation and Public Works

12:29 A.M. Public Hearing Opened

Public Speakers:

None

12:29 P.M. Public Hearing Closed

Board action: Approved as Recommended
UNANIMOUS VOTE
Approved by Resolution 18-0371

51. [11:10 A.M. - Freestone Water System Financing: Hold a public hearing on the annual written report for County Service Area No. 41 Freestone Water System and adopt the resolution ordering the annual water charge to be collected on the County of Sonoma tax roll for the total amount of \\$14,142.60 for Fiscal Year 2018-19. \(Fifth District\)\(4/5th Vote Required\)](#)

12:29 P.M.

Presenters:
Trish Pisenti, Interim Deputy Director, Transportation and Public Works
Adrian Diaz, Department Analyst, Transportation and Public Works

12:29 P.M. Public Hearing Opened

Public Speakers:
None

12:29 P.M. Public Hearing Closed

Board action: Approved as Recommended
UNANIMOUS VOTE
Approved by Resolution 18-0372

BOARD OF SUPERVISORS

52. [Fee Waiver: Approve a fee waiver in the amount of \\$10,275 by Redwood Empire Food Bank for use of the Sebastopol Center for the Arts, the Guerneville Veterans Building, the Santa Rosa Veterans Memorial Building and the Petaluma Veterans Memorial Building. \(Second, Third, and Fifth Districts\)](#)

12:30 P.M.

12:31 A.M. Public Comment Opened

Public Speakers:
None

12:31 P.M. Public Comment Closed

Board action: Approved as Recommended
UNANIMOUS VOTE

VI. 11:46 A.M. - PRESENTATIONS/GOLD RESOLUTIONS

This item taken out of order.

VII. BOARD MEMBER REPORTS ON ASSIGNED BOARDS, COUNCILS, COMMISSIONS OR OTHER ATTENDED MEETINGS

12:33 P.M. Supervisor Zane attended the San Diego Emergency Climate Adaptation meetings with Supervisor Rabbitt and Mike Gossman. She announced that she is also going to San Mateo later this month to share what she has learned about disaster preparedness response and recovery. She also announced that she will be speaking at affiliate events of the governor's Global Action Summit at the Bay Area Air Quality Management.

12:37 P.M. Supervisor Rabbitt attended the San Diego Emergency Climate Adaptation meetings, he also visited Washington D.C. with the North Bay Rebuild foundation with Mike Gossman and met with Dianne Feinstein's office to discuss issues with Federal Emergency Management Agency (FEMA) and Community Development Block Grant Program - Disaster Recovery (CDBG-DR). He also met with a staff committee from Homeland Security and the US Chamber of Commerce Foundation. Yesterday, he attended the Sonoma County Transportation Authority meeting.

12:40 P.M. Supervisor Gorin attended the Sonoma County Transportation Authority and Sonoma County Regional Climate Protection Authority meetings related to housing figures. She announced a survey online from the Bay Area Council on the kind of units the workforce would like to see built.

12:43 P.M. Supervisor Hopkins attended a Local Agency Formation Commission meeting, where there was a step towards the consolidation of four significant fire agencies. She also attended the first Fire Implementation Adhoc with Supervisor Rabbitt, where they made a recommendation to preserve staffing.

12:45 P.M. Supervisor Gore attended a North Sonoma County Air Pollution Control District meeting, he also attended meetings with California State Association of Counties (CSAC) and National Association of Counties (NACO) members on SB901 and hazard planning. This week he will be attending affiliate and Global Climate events.

VIII. [12:49 P.M. - PUBLIC COMMENT ON MATTERS NOT LISTED ON THE AGENDA BUT WITHIN THE SUBJECT MATTER JURISDICTION OF THE BOARD AND ON BOARD MEMBER REPORTS](#)
[\(Comments are restricted to matters within the Board's jurisdiction. The Board will hear public comments at this time for up to thirty minutes. Each person is usually granted time to speak at the discretion of the Chair. Any additional public comments will be heard at the conclusion of the meeting. While members of the public are welcome to address the Board, under the Brown Act, Board members may not deliberate or take action on items not on the agenda.\)](#)

12:49 P.M. Public Comment Opened

Public Speakers:

Duane De Witt
Gregory Fearon
Bob Hansen
Michelle Miller
Mary Morrison
Roseanne Snyder
James Hill
Rachel Bell
Maureen De Voe
Shelby
Richard Hannon
John Jenkel
Anita Selgado
Scott Wagner
Colleen Fernaud

1:24 P.M. Public Comment Closed

53. [Permit and Resource Management Department: Review and possible action on the following: Acts and Determinations of Planning Commission/Board of Zoning Adjustments Acts and Determinations of Project Review and Advisory Committee Acts and Determinations of Design Review Committee Acts and Determinations of Landmarks Commission Administrative Determinations of the Director of Permit and Resource Management \(All materials related to these actions and determinations can be reviewed at: <http://www.sonoma-county.org/prmd/b-c/index.htm>\)](#)

1:25 P.M.

Board Action: The Board accepted the Acts and Determinations.
UNANIMOUS VOTE

54. [ADJOURNMENT](#)

2:25 P.M. The Board adjourned the meeting in the memory of John Kerr and those who perished on September 11, 2001.

The meeting was adjourned to September 18, 2018 at 8:30 A.M.

Respectfully submitted,

Kay Lowtrip,
Chief Deputy Clerk of the Board

NOTE: The next Regular meeting will be held on September 18, 2018, at 8:30 a.m.

Upcoming Hearings (All dates are tentative until each agenda is finalized)

October 23, 2018 - Permit and Resource Management â€ˆ PLP05-0062 Hale Winery September 11, 2018 2

ACTION SUMMARY
BOARD OF SUPERVISORS
SONOMA COUNTY
575 ADMINISTRATION DRIVE, ROOM 102A
SANTA ROSA, CA 95403

TUESDAY

SEPTEMBER 18, 2018

8:30 A.M.

Susan Gorin	First District	Sheryl Bratton	County Administrator
David Rabbitt	Second District	Bruce Goldstein	County Counsel
Shirlee Zane	Third District		
James Gore	Fourth District		
Lynda Hopkins	Fifth District		

8:38 A.M. CALL TO ORDER

Supervisors Present: Susan Gorin, David Rabbitt, Shirlee Zane, James Gore, Lynda Hopkins

Staff Present: Sheryl Bratton, County Administrator and Bruce Goldstein, County Counsel

PLEDGE OF ALLEGIANCE

I. **[APPROVAL OF THE AGENDA \(Items may be added or withdrawn from the agenda consistent with State law\)](#)**

The recommended action A for item 19 was amended to read:

Delegate authority to the Director of the General Services Department to negotiate and execute an agreement with Thompson Builders Corporation, as the proposer with the best-value proposal for the Main Adult Detention Facility Inmate Connector Project, for design-build services to construct the Inmate Connector Project and related work in an amount not to exceed \$9,085,658 and otherwise consistent with Thompson Builders' Proposal for the Project, and subject to other appropriate final terms as determined by the General Services Department and as otherwise approved by County Counsel. (Majority)

Board action: Approved as Amended
UNANIMOUS VOTE

II. **[CONSENT CALENDAR](#)**

8:54 A.M. Public Comment Opened

Public Speakers:
Glen Ross
Terry Leen
Robert Piazza
Debra DeMartini
Steve Kemmerle
Thomas Ells
Michael Goldberg

9:11 A.M. Public Comment Closed

HEALTH SERVICES/HUMAN SERVICES/ PROBATION/DISTRICT ATTORNEY'S OFFICE/PUBLIC DEFENDER'S OFFICE

AND

COMMUNITY DEVELOPMENT COMMISSION
(Commissioners: Gorin, Rabbitt, Zane, Gore, Hopkins)

1. **[Homeless Mentally Ill Outreach and Treatment Program Funding Resolution: Adopt a resolution authorizing participation in the one-time Homeless Mentally Ill Outreach and Treatment Program funding opportunity available as a result of Senate Bill 840.](#)**

Board action: Approved as Recommended
UNANIMOUS VOTE
Approved by Resolution 18-0373

BOARD OF SUPERVISORS

2. [Disbursement of Fiscal Year 2018-2019 1st District Community Investment Fund Grant Awards: Approve Community Investment Fund grant awards and Authorize the County Administrator, or designee, to execute an agreement with the following non-profit entities for advertising and economic development efforts for FY 2018-2019: Children's Museum of Sonoma County, \\$1,000; Art Escape, \\$2,500; Valley of the Moon Natural History Association DBA Jack London Park Partners, \\$2,500; Sonoma Valley Visitor's Bureau, \\$2,500; Sonoma Valley Education Foundation Red and White Ball, \\$2,500; Agricultural Community Events Farmers Market The Springs Community Farmer's Market, \\$2,000; Sonoma County Pride onoma County LGBTQI Pride Summer Celebration 2019, \\$500; Sebastiani Theatre Foundation, Inc., \\$5,000; Glen Ellen Fair Association DBA Glen Ellen Village Fair, \\$2,000. \(First District\)](#)

Board action: Approved as Recommended
UNANIMOUS VOTE

3. [Disbursement of Fiscal Year 2018-2019 Fourth District Community Investment Fund Grant Awards: Approve Community Investment Fund grant awards and Authorize the County Administrator, or designee, to execute an agreement with the following non-profit entities for advertising and promotions activities for FY 2018-2019: Active 20-30 Club Red White and Boom, \\$1,500; Alexander Valley Film Society Alexander Valley Film Festival, \\$2,500; Boys and Girls Clubs of Central Sonoma County 2018/2019 program, \\$2,500; Cloverdale Historical Society Cloverdale Sculpture Trail, \\$1,000; Friends of Lake Sonoma 2019 Lake Sonoma Steelhead Festival, \\$1,500; Geyserville Chamber of Commerce Fall Colors, \\$1,000; Geyserville Lodging Association Beer, Wine, and Spirits Festival, \\$800; Rotary Club of Cloverdale's Asti Tour De Vine, \\$500. \(Fourth District\)](#)

Board action: Approved as Recommended
UNANIMOUS VOTE

4. [Disbursement of Fiscal Year 2018-2019 Fifth District Community Investment Fund Grant Awards: Approve Community Investment Fund grant awards and Authorize the County Administrator, or designee, to execute an agreement with the following non-profit entities for advertising and economic development efforts for FY 2018-2019: Children's Museum of Sonoma County monthly events and programming, \\$3,000; City of Sebastopol Housing Fair, \\$500; Coastwalk California Clean Up Day 2018, \\$1,500; Graton Community Club Spring and Fall Flower Shows, \\$1,000; Los Cien Sonoma County Inc. voter education program, State of Latino Forum, and monthly events, \\$2,500; Russian River Chamber of Commerce online social media marketing program, \\$3,500; Russian River Rotary Foundation Rockin the River Concert series, \\$5,000; Sebastopol Area Senior Center Legacy Thrift Shop and Holiday Store, \\$2,765; Sebastopol Chamber of Commerce and Visitor Center Apple Blossom Festival and Parade, \\$2,000; Slow Food promotion of local grown apples at Sonoma County Airport, \\$1,000; Stewards of the Coast and Redwoods three events, \\$5,000 and Surfrider Foundation Sonoma Coast Annual Blue Water Paddle Race, \\$1,000. \(Fifth District\)](#)

Board action: Approved as Recommended
UNANIMOUS VOTE

COUNTY ADMINISTRATOR

5. [Recovery Update: Receive an update on the status of recovery operations, planning, seeking of funding opportunities, community engagement and status of recovery plan.](#)

Board action: Approved as Recommended
UNANIMOUS VOTE

GENERAL SERVICES/SHERIFF'S OFFICE

6. [Sonoma Raceway Radio Communications Site Lease, Sears Point, Hwy 37/121: Authorize the General Services Director to execute a lease with Speedway Sonoma, LLC, \(Landlord\) for premises located at 29355 Arnold Drive, Sonoma, CA 95476 \(also known as Sears Point\) at the intersection of Hwy 37 and 121 \(Assessor's Parcel No. 068-](#)

150-056). The initial term of the Lease will be ten (10) years, with four (4) additional five (5) year extensions. In lieu of monetary rent owed by the County, County shall provide landlord with use of the new improvements County will construct on the lease premises (2nd action). This lease will afford the County and its residents a direct and substantial community benefit, namely an improved and more reliable public safety communications network in southern Sonoma County and the future ability to install fire watch cameras at the site. (2nd action)(Second District)

Board action: Approved as Recommended
UNANIMOUS VOTE

GENERAL SERVICES

7. Veterans Memorial Building Use Policy: Adopt the Veteran’s Memorial Building Use Policy to establish and clarify scheduling, fee, and other usage policies regarding uses of the Sonoma County Veterans Memorial Buildings by Veterans organizations, Veterans and community users.

Board action: Approved as Recommended
UNANIMOUS VOTE

HUMAN RESOURCES

8. Memorandum of Understanding extension between the County of Sonoma and the Sonoma County Prosecutors Association: Adopt a Resolution approving an extension to the Memorandum of Understanding (MOU) between the County of Sonoma (County) and the Sonoma County Prosecutors Association (SCPA) for the period of September 18, 2018 through May 6, 2019.

Board action: Approved as Recommended
UNANIMOUS VOTE
Approved by Resolution 18-0374

9. Memorandum of Understanding extension between the County of Sonoma and the Sonoma County Deputy Public Defender Attorneys Association: Adopt a Resolution approving an extension to the Memorandum of Understanding (MOU) between the County of Sonoma (County) and the Sonoma County Deputy Public Defenders Association (SCDPDAA) for the period of September 18, 2018 through May 6, 2019.

Board action: Approved as Recommended
UNANIMOUS VOTE
Approved by Resolution 18-0375

PERMIT AND RESOURCE MANAGEMENT

10. Application to California Coastal Commission for Local Coastal Plan Grant: Adopt a resolution authorizing Permit Sonoma to submit a planning grant application to the California Coastal Commission for \$200,000 in funding for a Local Coastal Program Update to include climate adaption policies for sea level rise and greenhouse gas emissions reductions.

Board action: Approved as Recommended
UNANIMOUS VOTE
Approved by Resolution 18-0376

SHERIFF’S OFFICE

11. Agreement for Telecommunication Installation and Maintenance Services: Authorize the Sherriff to execute the Agreement for Telecommunication Installation and Maintenance Services between the Sheriff’s Office and the City of Petaluma. The estimated revenue for installation in FY 18/19 is \$48,582. After FY 18/19, the maintenance revenue is estimated to be \$12,444 annually.

Board action: Approved as Recommended
UNANIMOUS VOTE

APPOINTMENTS/REAPPOINTMENTS

12. [Approve the Reappointment of Regina De La Cruz to Agricultural Preservation and Open Space District Fiscal Oversight Commission, representing the Third District, for a term of two years, beginning September 27, 2018 and ending September 27, 2020. \(Third District\)](#)

Board action: Approved as Recommended
UNANIMOUS VOTE

13. [Approve the Appointment of David Hubbell to the Bicycle and Pedestrian Advisory Committee as the 4th District Alternate for a for a two year term beginning September 18, 2018 and expiring September 18, 2020. \(Fourth District\)](#)

Board action: Approved as Recommended
UNANIMOUS VOTE

PRESENTATIONS/GOLD RESOLUTIONS

PRESENTATIONS AT THE BOARD MEETING

(Gold resolutions are presented in the afternoon session at 1:30 P.M.)

14. [Adopt a Gold Resolution Declaring September 2018 as Prostate Cancer Awareness Month. \(Fourth District\)](#)

Board action: Approved as Recommended
UNANIMOUS VOTE
Approved by Resolution 18-0377

15. [Adopt a Gold Resolution recognizing September 15, 2018 through October 15, 2018 as Latino Heritage Month. \(Fifth District\)](#)

Board action: Approved as Recommended
UNANIMOUS VOTE
Approved by Resolution 18-0378

PRESENTATIONS ON A DIFFERENT DATE

16. [Adopt a Gold resolution honoring the FARMS Leadership Program for celebrating 20 years of providing hands-on sustainable farming and environmental stewardship experiences to Sonoma County youth. \(Fifth District\)](#)

Board action: Approved as Recommended
UNANIMOUS VOTE
Approved by Resolution 18-0379

8:54 A.M. Public Comment Opened

Public Speakers:

Glen Ross
Terry Lean
Robert Piazza
Debra DeMartini
Steve Kennedy
Thomas Ells
Michael Goldberg

9:11 A.M. Public Comment Closed

Board Action: Approved as Recommended
UNANIMOUS VOTE

III. 9:12 A.M. - PUBLIC COMMENT ON MATTERS NOT LISTED ON THE AGENDA BUT WITHIN THE SUBJECT MATTER JURISDICTION OF THE BOARD AND ON BOARD MEMBER REPORTS
(Comments are restricted to matters within the Board's jurisdiction. The Board will hear public comments at this time for up to thirty minutes. Each person is usually granted time to speak at the discretion of the Chair. Any additional public comments will be heard at the conclusion of the meeting. While members of the public are welcome to address the Board, under the Brown Act, Board members may not deliberate or take action on items not on the agenda.)

9:12 A.M. Public Comment Opened

Public Speakers:

Joel Evans-Fudem

Jamie Ott

Monica Edwards

Shannen Fraley

Francisco Saiz

Susan Lamont

Annette Elder Evins

Michelle Miller

James Savage

Shelby

Mary Morrison

Roseanne Snyder

Rachel Bell

Richard Hannon

John Jenkel

Thomas Ells

Scott Wagner

Anita Layfollette

Paul Libeu

9:55 A.M. Public Comment Closed

IV. REGULAR CALENDAR

HUMAN RESOURCES

17. Memorandum of Understanding extension between the County of Sonoma and the Sonoma County Law Enforcement Management Association and Government Code 7507 disclosure:
 - A) Adopt a Resolution approving an extension to the Memorandum of Understanding (â€œMOUâ€œ) between the County of Sonoma and the Sonoma County Law Enforcement Management Association (â€œSCLEMAâ€œ) for the period of September 25, 2018, through July 2, 2019.
 - B) Receive and Review a Tentative Agreement for the modification of Article 6 (Medical Benefits for Future Retirees) of the Memorandum of Understanding (â€œMOUâ€œ) between the County and SCLEMA for the period of September 25, 2018, through July 2, 2019, so that the Board is informed to receive an actuarial valuation of the impact of proposed changes in retiree medical benefits for SCLEMA members of bargaining unit 44, pursuant to California Government Code Section 7507.

9:57 A.M.

Presenters:

Carol Allen, Deputy Director, Human Resources

10:01 A.M. Public Comment Opened

Public Speakers:

None

10:02 P.M. Public Comment Closed

Board action: Approved as Recommended
UNANIMOUS VOTE
Approved by Resolution 18-0380

GENERAL SERVICES/AUDITOR-CONTROLLER/TREASURER-TAX COLLECTOR

AND

SONOMA COUNTY PUBLIC FINANCING AUTHORITY

AND

SONOMA COUNTY WATER AGENCY

(Directors: Gorin, Rabbitt, Zane, Gore, Hopkins)

18. Sonoma County Energy Independence Program Semi-Annual Bonding Authorization, Update and Annual Interest Rate Determination:
- A) Accept the Sonoma County Energy Independence Program update through fiscal year 2018.
 - B) Acting as the Board of Directors of the Sonoma County Public Finance Authority: Adopt resolutions and approve agreements with the County authorizing continued issuance and sale of revenue bonds, to fund the Sonoma County Energy Independence Program; and
 - C) Acting as the County Board of Supervisors: Adopt resolutions authorizing the Treasurer to invest in bonds issued by the Public Finance Authority and authorizing execution of various related agreements with the Public Finance Authority, including a bond purchase agreement and a loan agreement; and
 - D) Acting as the Directors of the Sonoma County Water Agency: Adopt resolutions withdrawing funds from the County Treasury Pool, and authorizing the withdrawn funds to be invested in Sonoma County Energy Independence Program bonds as a long-term Water Agency investment; and
 - E) Adopt resolutions and approve agreements with the County authorizing continued issuance and sale of revenue bonds, determination of the interest rate and loan of funds to the County, to fund the Sonoma County Energy Independence Program.

10:02 A.M.

Presenters:
Caroline Judy, Director, General Services
Erick Roeser, Auditor, Controller, Treasurer, Tax Collector
Jane Elias, Program Manager Department, General Services

11:00 A.M. Public Comment Opened

Public Speakers:
Thomas Ells

11:02 A.M. Public Comment Closed

Board action: Approved as Recommended
UNANIMOUS VOTE
Approved by Resolution 18-0381 through 18-0387

GENERAL SERVICES/SHERIFF'S OFFICE

19. Main Adult Detention Facility Inmate Connector:
- A) Award a design build contract with Thompson Builders Corporation for the Main Adult Detention Facility Inmate Connector in the amount of \$9,085,658. (Majority)

- B) [Adopt Resolution authorizing budgetary transfer within the Capital Projects FY 2018-19 Adopted budget in the amount of \\$2,887,096 to provide a portion of the funds necessary for the Inmate Connector project. \(Majority\)](#)
- C) [Adopt Resolution authorizing the budgetary transfer of General Fund contingencies in the amount of \\$1,166,112 to complete the total \\$14,502,409 funding required for the Inmate Connector project. \(4/5th Vote Required\)](#)

11:04 A.M.

Presenters:

Caroline Judy, Director, General Services
Al Vernon, Assistant Sheriff
Bruce Oveson, Senior Capital Projects Manager, General Services
John Brencic, Senior Project Specialist, General Services

11:28 A.M. Public Comment Opened

Public Speakers:

None

11:28 A.M. Public Comment Closed

Board action: Approved as Amended

UNANIMOUS VOTE

Approved by Resolution 18-0388 and 18-0389

V. [PUBLIC COMMENT ON CLOSED SESSION ITEMS](#)

11:29 A.M. Public Comment Opened

Public Speakers:

Kathleen Finnegan
Susan Lamont
Scott Wagner
Sean Duffey
Francisco Saiz
Thomas Ells

11:37 A.M. Public Comment Closed

VI. [CLOSED SESSION CALENDAR](#)

1:41 P.M. The Chair deferred the Closed Session Report until after Item 26.

2:54 P.M. County Counsel Bruce Goldstein reported on Closed Session items 20 through 22.

- 20. [The Board of Supervisors will consider the following in closed session: Conference with Legal Counsel Existing Litigation California North Bay Fire Cases, San Francisco Superior Court, JCCP 4955 \(Government Code Section 54956.9\(d\)\(1\).\)](#)

No reported action. Direction was given to counsel and staff.

- 21. [The County of Sonoma Board of Supervisors will meet in closed session for the following: Public Employee Appointment, Independent Office of Law Enforcement Review and Outreach Director. \(Government Code Section 54957\(b\)\(1\)\).](#)

The Board authorized the Human Resources Director to initiate a recruitment of the Independent Office of Law Enforcement Review and Outreach Director and develop a recruitment plan.

AYES: Gorin, Zane, Gore, Hopkins

NOES: Rabbitt

22. [The Board of Supervisors, the Board of Directors of the Water Agency, the Board Commissioners of the Community Development Commission, and the Board of Directors of The Agricultural Preservation and Open Space District will consider the following in closed session: Conference with Labor Negotiators: Christina Cramer/Carol Allen, County of Sonoma, and Rick Bolanos/Heather Coffman, Liebert Cassidy & Whitmore. Employee Organizations: All. Unrepresented employees: All, including retired employees. \(Government Code section 54957.6\).](#)

No reportable action. Direction was given to Labor Negotiators.

VII. [1:41 P.M. REGULAR AFTERNOON CALENDAR](#)

23. [1:41 P.M. RECONVENE FROM CLOSED SESSION](#)

Supervisors Present: Susan Gorin, David Rabbitt, Shirlee Zane, James Gore and Lynda Hopkins

Staff Present: Sheryl Bratton, County Administrator and Bruce Goldstein, County Counsel

24. [REPORT ON CLOSED SESSION](#)

1:41 P.M. The Chair deferred the Closed Session Report until after Item 26.

2:45 P.M. County Counsel Bruce Goldstein reported on Closed Session Items 20 through 22.

VIII. [1:41 P.M. - PRESENTATIONS/GOLD RESOLUTIONS](#)

[BOARD OF SUPERVISORS](#)

25. [Home Rebuilds in G Geologic Hazard Area Combining District Minute Order:](#)

- A) [Approve a minute order resolution directing the Permit and Resource Management Department \(Permit Sonoma\) and County Counsel to:](#)
- i. [Initiate the process to amend the General Plan and Zoning Code to specify that geologic reports are not required to rebuild single-family homes that were located in the G Geologic Hazard Area Combining District and destroyed in the Sonoma Complex Fires, and](#)
 - ii. [Concurrently investigate the feasibility of obtaining a Governor's Executive Order under Government Code section 8571, to temporarily and immediately suspend geologic report requirements to facilitate rebuilding of single-family homes that were located in the G Combining District and destroyed in the Sonoma Complex Fires.](#)
- B) [Approve a budgetary adjustment resolution authorizing use of contingency funds in an amount up to \\$76,010 to cover associated Permit and Resource Management Department and County Counsel staff time costs, should the Executive Order not immediately issue. \(4/5 Vote Required\) \(Fourth District\)](#)

2:14 P.M.

Presenters:

Tennis Wick, Director, Permit and Resource Management Department
Christa Shaw, Deputy County Counsel

2:22 P.M. Public Comment Opened

Public Speakers:

John Reinecke
Lisa Frieze
Kea Roch
Jennifer Honey
Buchard Fargo
Albert Stoll

Fernando Mora
David Parkinson
Kim Davis

2:39 P.M. Public Comment Closed

Board action: Approved as Recommended
UNANIMOUS VOTE
Approved by Resolutions 18-0390 and 18-0391

IX. [BOARD MEMBER REPORTS ON ASSIGNED BOARDS, COUNCILS, COMMISSIONS OR OTHER ATTENDED MEETINGS](#)

26. [Permit and Resource Management Department: Review and possible action on the following: Acts and Determinations of Planning Commission/Board of Zoning Adjustments](#)
[Acts and Determinations of Project Review and Advisory Committee](#)
[Acts and Determinations of Design Review Committee](#)
[Acts and Determinations of Landmarks Commission](#)
[Administrative Determinations of the Director of Permit and Resource Management](#)
(All materials related to these actions and determinations can be reviewed at:
<http://www.sonoma-county.org/prmd/b-c/index.htm>)

3:04 P.M.

Board Action: Approved as Recommended
UNANIMOUS VOTE

27. [ADJOURNMENT](#)

3:06 P.M. The Board adjourned the meeting in the memory of Lee Whitney, Claire Daniels, Violet Chapel Parrish and Ulises Valdez.

The meeting was adjourned to September 25, 2018 at 8:30 A.M.

Respectfully submitted,

Kay Lowtrip,
Chief Deputy Clerk of the Board

NOTE: The next Regular meeting will be held on September 25, 2018, at 8:30 a.m.

Upcoming Hearings (All dates are tentative until each agenda is finalized)
October 23, 2018 - Permit and Resource Management PLP05-0062 Hale Winery

ACTION SUMMARY
BOARD OF SUPERVISORS
SONOMA COUNTY
575 ADMINISTRATION DRIVE, ROOM 102A
SANTA ROSA, CA 95403

TUESDAY

SEPTEMBER 25, 2018

8:30 A.M.

Susan Gorin	First District	Sheryl Bratton	County Administrator
David Rabbitt	Second District	Bruce Goldstein	County Counsel
Shirlee Zane	Third District		
James Gore	Fourth District		
Lynda Hopkins	Fifth District		

8:32 A.M. CALL TO ORDER

Supervisors Present: James Gore, David Rabbitt, Shirlee Zane, Lynda Hopkins

Supervisors Absent: Susan Gorin

Staff Present: Sheryl Bratton, County Administrator and Bruce Goldstein, County Counsel

PLEDGE OF ALLEGIANCE

I. [APPROVAL OF THE AGENDA \(Items may be added or withdrawn from the agenda consistent with State law\)](#)

Supervisor Gore announced that there was a correction to the recommended action for item 11, the Hauser Bridge Replacement project, the action A was added:

A) Approve the Settlement Remediation Plan for Change Order Number 8 to the construction contract with Granite Construction, Project Number C11006.

B) Approve and authorize Chair to sign Change Order Number 8 to the construction contract with Granite Construction, Inc. in the amount of \$173,600.00 for a total contract amount of \$5,006,647.62 for modifications to the Hauser Bridge onsite drainage design.

The recommended action previously read:

Approve and authorize Chair to sign Change Order Number 8 to the construction contract with Granite Construction, Inc. in the amount of \$173,600.00 for a total contract amount of \$5,006,647.62 for modifications to the Hauser Bridge onsite drainage design.

Supervisor Gore also announced that there had been amendments to the resolution for item 4, which had been posted online.

Board Action: Approved as Amended

AYES: Gore, Rabbitt, Zane, Hopkins

ABSENT: Gorin

II. [CONSENT CALENDAR](#)

8:51 A.M. Public Comment Opened

Speakers:

None

8:51 A.M. Public Comment Closed

HUMAN RESOURCES/BOARD OF SUPERVISORS
AND
AGRICULTURAL PRESERVATION AND OPEN SPACE DISTRICT/

SONOMA COUNTY WATER AGENCY
(Directors: Gorin, Rabbitt, Zane, Gore, Hopkins)
AND
COMMUNITY DEVELOPMENT COMMISSION
(Commissioners: Gorin, Rabbitt, Zane, Gore, Hopkins)

1. [Miscellaneous Classification, Compensation, and Allocation Changes: Adopt Concurrent Resolutions reflecting the recommendations of completed classification studies and other position allocation changes:](#)
- A) [Adopt a Concurrent Resolution amending the Memorandum of Understanding between the County and SEIU Local 1021, Salary Table Scales, to establish five new APOSD classifications and salaries; to revise and retitle seven APSOD classifications; to adjust the salaries for six APOSD classifications; and to delete one classification, effective September 25, 2018.](#)
- B) [Adopt a Concurrent Resolution amending the Salary Resolution No. 95-0926, Appendix A Salary Tables, to establish three new APOSD classifications and salaries; to revise and retitle three APOSD classifications; to adjust salaries for two APOSD classifications; and to delete two classifications, effective September 25, 2018.](#)
- C) [Adopt a Concurrent Resolution approving the reclassification of nine APOSD positions, with the promotion of affected incumbents; and amending the Allocation Tables of the Agricultural Preservation and Open Space District, the General Services Department, the Auditor-Controller-Treasurer-Tax Collector, the Information Systems Department, and the Sonoma County Water Agency, effective September 25, 2018.](#)

Board Action: Approved as Recommended
AYES: Gore, Rabbitt, Zane, Hopkins
ABSENT: Gorin
Approved by Resolution 18-0392, 18-0393 and 18-0394

COUNTY ADMINISTRATOR/ FIRE AND EMERGENCY SERVICES

2. [Extend Proclamation of Local Emergency Due to Sonoma Complex Fire: Adopt a Resolution Extending the Proclamation of Local Emergency Issued on October 9, 2017, for another 30 Days Due to Damage Arising from the Complex Fire. \(4/5th Vote Required\)](#)

Board Action: Approved as Recommended
AYES: Gore, Rabbitt, Zane, Hopkins
ABSENT: Gorin
Approved by Resolution 18-0395

COUNTY ADMINISTRATOR

3. [Recovery Update: Receive update on the status of recovery operations, planning, seeking of funding opportunities, community engagement and status of recovery framework.](#)

Board Action: Approved as Recommended
AYES: Gore, Rabbitt, Zane, Hopkins
ABSENT: Gorin

COUNTY COUNSEL

4. [Approval of amendments to the Statewide Community Infrastructure Program \(SCIP\) Acquisition Agreement for Paseo Vista: Adopt a resolution approving the form of the First Amendment to Acquisition Agreement among City of Santa Rosa, County of Sonoma, and Paseo Vista Inc. \(Fifth District\)](#)

Board Action: Approved as Amended
AYES: Gore, Rabbitt, Zane, Hopkins
ABSENT: Gorin
Approved by Resolution 18-0396

HEALTH SERVICES

5. [Medtronic Foundation Grant to Support Health Action: Authorize the Director of Health Services to execute an agreement with Medtronic Foundation for the County of Sonoma to receive revenue to support Health Action efforts to design and implement new strategies for community engagement and collaboration in the amount of \\$100,000 for the period of August 1, 2018 to August 31, 2020. \(4/5th Vote Required\)](#)

Board Action: Approved as Recommended

AYES: Gore, Rabbitt, Zane, Hopkins

ABSENT: Gorin

HUMAN SERVICES

6. [Board Resolution to accept funding for Victims of Crime Act \(VOCA XE\) and Victims of Crime Act \(VOCA KE\) Specialized Emergency Housing: Adopt a resolution authorizing the Director of the Human Services Department to accept funding in the amount of:](#)
 - A) [\\$400,000 for a three year period from 7/1/2016 to 12/31/2019. This CalOES funding through the VOCA XE program provides victim advocacy, care coordination and legal assistance for elder and dependent adult victims of crime; and](#)
 - B) [\\$595,000 from 10/1/2017 to 11/1/2019. This CalOES funding through the VOCA KE program addresses transitional emergency housing for elder and dependent adult victims of crime.](#)

Board Action: Approved as Recommended

AYES: Gore, Rabbitt, Zane, Hopkins

ABSENT: Gorin

Approved by Resolution 18-0397

REGIONAL PARKS

7. [Cooper Creek addition to Taylor Mountain Habitat Conservation Fund Grant: Adopt a resolution authorizing the Director of Regional Parks to apply for the State Parks Habitat Conservation Fund in the amount of \\$220,000 for Cooper Creek addition to Taylor Mountain Regional Park and Open Space Preserve acquisition and authorizing the Director of Regional Parks to execute all documents which may be necessary to carry out and administer the grant. \(Third District\)](#)

Board Action: Approved as Recommended

AYES: Gore, Rabbitt, Zane, Hopkins

ABSENT: Gorin

Approved by Resolution 18-0398

SHERIFF'S OFFICE

8. [Surrendered and Abandoned Vessel Exchange \(SAVE\) Grant, \\$40,000: Adopt a resolution authorizing the Sheriff to execute the California Department of Parks and Recreation, Division of Boating and Waterways, Surrendered and Abandoned Vessel Exchange \(SAVE\) grant agreement providing funding in the amount of \\$40,000 for the Sheriff's Office Marine Unit to dispose of surrendered, wrecked, and abandoned recreational boats through September 30, 2020. The grant promotes navigational and environmental safety on Sonoma County waterways by removing, reducing, and preventing abandoned recreational vessels and marine debris.](#)

Board Action: Approved as Recommended

AYES: Rabbitt, Zane, Hopkins, Gore

ABSENT: Gorin

Approved by Resolution 18-0399

9. [Electronic Monitoring Annual Review: Receive and review the 2018 Administrative Policy for the Electronic Monitoring Program to comply with electronic monitoring program regulations as required by Penal Code 1203.16, 1203.17 and 1203.18. The Sheriff's Electronic Monitoring Program serves as a cost-effective detention alternative for](#)

[Sonoma County to manage its jail population by lawfully offering a home detention alternative to low/moderate risk adult inmates in lieu of incarceration.](#)

Board Action: Approved as Recommended
AYES: Gore, Rabbitt, Zane, Hopkins
ABSENT: Gorin

TRANSPORTATION AND PUBLIC WORKS

10. [2018 Fire Damaged Guardrail Replacement Project M11720:](#)
 - A) [Approve the plans and specifications for replacement of 2000 linear feet of guardrail and 305 linear feet of wooden sound wall in the 2018 Fire Damaged Guardrail Replacement Project M11720](#)
 - B) [Award contract to low bidder, Midstate Barrier, Inc. in the amount of \\$216,345.00, plus a 10% contingency and authorize the Chair to execute construction contract M11720. \(First and Fourth Districts\)](#)

Board Action: Approved as Recommended
AYES: Gore, Rabbitt, Zane, Hopkins
ABSENT: Gorin

11. [Hauser Bridge Replacement Project, C11006, Contract Change Order: Approve and authorize Chair to sign Change Order Number 8 to the construction contract with Granite Construction, Inc. in the amount of \\$173,600.00 for a total contract amount of \\$5,006,647.62 for modifications to the Hauser Bridge onsite drainage design. \(Fifth District\)](#)

Board Action: Approved as Amended
AYES: Gore, Rabbitt, Zane, Hopkins
ABSENT: Gorin

APPOINTMENTS/REAPPOINTMENTS

12. [Approve the Reappointment of Jim Redding to the Advisory Council to Area Agency on Aging, Sonoma County, for a period of two years, beginning September 20, 2018 and ending on September 20, 2020. \(Third District\).](#)

Board Action: Approved as Recommended
AYES: Gore, Rabbitt, Zane, Hopkins
ABSENT: Gorin

PRESENTATIONS/GOLD RESOLUTIONS

PRESENTATIONS AT THE BOARD MEETING

(Gold resolutions are presented in the afternoon session at 1:30 P.M.)

13. [Adopt Gold Resolution recognizing September 25, 2018, as National Voter Registration Day. \(Clerk Recorder Assessor\)](#)

Board Action: Approved as Recommended
AYES: Gore, Rabbitt, Zane, Hopkins
ABSENT: Gorin
Approved by Resolution 18-0400

14. [Adopt a Gold Resolution recognizing National 4-H Week, October 7th through the 13th, 2018. \(University of California Cooperative Extension\)](#)

Board Action: Approved as Recommended
AYES: Gore, Rabbitt, Zane, Hopkins
ABSENT: Gorin
Approved by Resolution 18-0401

PRESENTATIONS ON A DIFFERENT DATE

15. [Adopt a Gold Resolution congratulating Safari West on its anniversary marking 25 years of wildlife preservation and contributions to the world of natural conservation. \(Fourth District\)](#)

Board Action: Approved as Recommended

AYES: Gore, Rabbitt, Zane, Hopkins

ABSENT: Gorin

Approved by Resolution 18-0402

- III. [8:52 A.M. - PUBLIC COMMENT ON MATTERS NOT LISTED ON THE AGENDA BUT WITHIN THE SUBJECT MATTER JURISDICTION OF THE BOARD AND ON BOARD MEMBER REPORTS \(Comments are restricted to matters within the Board's jurisdiction. The Board will hear public comments at this time for up to thirty minutes. Each person is usually granted time to speak at the discretion of the Chair. Any additional public comments will be heard at the conclusion of the meeting. While members of the public are welcome to address the Board, under the Brown Act, Board members may not deliberate or take action on items not on the agenda.\)](#)

8:52 Public Comment Opened

Speakers:

Joel Evans-Fudem

Kristin Graetz

Janet Taylor

Michelle Miller

Mary Morrison

Roseanne Snyder

Siy Chelby

Maureen De Voe

James Savage

Shelby

Rachel Bell

Richard Hannon

John Jenkel

9:18 A.M. Public Comment Closed

- IV. [REGULAR CALENDAR](#)

COUNTY ADMINISTRATOR

16. [9:18 A.M. - Recovery and Resiliency Framework: Receive update on the draft Recovery and Resiliency Framework. \(Informational Only\)](#)

9:18 A.M.

Presenters:

Mike Gossman, Deputy County Administrator

Christel Querijero, Administrative Analyst, County Administrator's Office

Ben Stone, Economic Development Coordinator

Barbie Robinson, Director, Health Services

Karen Fies, Director, Human Services

10:45 A.M. Public Comment Opened

Speakers:

Will Abrams

Lisa Carreno

Thomas Ells

Trathen Heckman

Ana Salgado
Irma Garcia
Peter Tschernoff
Will Abrams
Teri Shore
Dee Swanhuysen
Michelle Miller
John Jenkel
Susan Shaw
Ana Lugo

11:58 A.M. Public Comment Closed

1:47 P.M. The Board paused the item to take Presentations of Gold Resolutions.

2:02 P.M. The Board returned to Item 16.

Board Action: Informational only

HUMAN RESOURCES

17. [Memorandum of Understanding extension between the County of Sonoma and the Sonoma County Law Enforcement Association \(SCLEA\) and Government Code 7507 disclosure:](#)
 - A) [Adopt a Resolution approving an extension to the Memorandum of Understanding \(MOU\) between the County of Sonoma and the Sonoma County Law Enforcement Association \(SCLEA\) for the period of May 8, 2018 - May 7, 2019.](#)
 - B) [Receive and Review a Tentative Agreement for the modification of Article 19 \(Medical Benefits for Future Retirees\) of the Memorandum of Understanding \(MOU\) between the County and SCLEA for the period of October 9, 2018, through May 7, 2019, so that the Board is informed to receive an actuarial valuation of the impact of proposed changes in retiree medical benefits for SCLEA members of bargaining units 30, 40, 41, and 70 pursuant to California Government Code Section 7507.](#)

2:53 P.M. This item was heard with Item 18.

Presenters:
Carol Allen, Employee Relations Manager, Human Resources

2:56 P.M. Public Comment Opened

Public Speakers:
None

2:56 P.M. Public Comment Closed

Board action: Approved as Recommended
AYES: Rabbitt, Zane, Gore, Hopkins
ABSENT: Gorin
Approved by Resolution 18-0403

18. [Memorandum of Understanding extension between the County of Sonoma and Sonoma County Public Defender Investigators Association and Government Code 7507 disclosure:](#)
 - A) [Adopt a Resolution approving an extension to the Memorandum of Understanding \(MOU\) between the County of Sonoma and the Sonoma County Public Defender Investigators Association \(SCPDIA\) for the period of June 18, 2018 - June 17, 2019.](#)

- B) [Receive and Review a Tentative Agreement for the modification of Article 16 \(Medical Benefits for Future Retirees\) of the Memorandum of Understanding \(MOU□\) between the County and SCPDIA for the period of October 9, 2018 through June 17, 2019, so that the Board is informed to receive an actuarial valuation of the impact of proposed changes in retiree medical benefits for SCPDIA members of bargaining unit 55 pursuant to California Government Code Section 7507.](#)

This item was heard with Item 17.

2:53 P.M.

Presenters:

Carol Allen, Employee Relations Manager, Human Resources

2:56 P.M. Public Comment Opened

Public Speakers:

None

2:56 P.M. Public Comment Closed

Board action: Approved as Recommended

AYES: Rabbitt, Zane, Gore, Hopkins

ABSENT: Gorin

Approved by Resolution 18-0404

BOARD OF SUPERVISORS

19. [Fee Waiver: Approve request to waive County of Sonoma Permit and Resource Management Department Use Permit and Administrative Design Review fees in the amount of \\$5,590.00 for the Lakeville Volunteer Fire Department. \(Second District\)](#)

This item was taken out of order.

3:26 P.M.

Presenters:

Supervisor Rabbitt, District 2

3:26 P.M. Public Comment Opened

Public Speakers:

None

3:26 P.M. Public Comment Closed

Board Action: Approved as Recommended

AYES: Gore, Rabbitt, Zane, Hopkins

ABSENT: Gorin

20. [Fee Waiver: Approve request for the UC Cooperative Extension, Sonoma County for a fee waiver in the amount of \\$987.50, for the Cloverdale Vets Memorial Building Auditorium Use fee of \\$987.50. The UC Cooperative Extension hosted the Living with Fire, Fire Preparedness Series meeting at the Vets Memorial Building entitled Preparing for Fires: Prescribed Burning and Grazing. \(Fourth District\)](#)

This item was taken out of order.

3:27 P.M.

Presenters:

Supervisor Gore, District 4

3:26 P.M. Public Comment Opened

Public Speakers:

None

3:27 P.M. Public Comment Closed

Board Action: Approved as Recommended

AYES: Gore, Rabbitt, Zane, Hopkins

ABSENT: Gorin

V. [PUBLIC COMMENT ON CLOSED SESSION ITEMS](#)

3:26 P.M. Public Comment Opened

Public Speakers:

None

3:26 P.M. Public Comment Closed

VI. [CLOSED SESSION CALENDAR](#)

21. [The Board of Supervisors will consider the following in closed session: Conference with Legal Counsel- Existing Litigation - County of Sonoma v. Timothy Pamatmat, Peggy Pamatmat, et al., SCV 247878. 9000 Argonne Way, Forestville, CA 95436-9382. District 5 \(Government Code Section 54956.9\(d\)\(1\).\)](#)

The Board authorized the settlement of the code enforcement case against Timothy Pamatmat and Peggy Pamatmat and approve a waiver of 90% of the penalties for a payment to the County of \$14,019. In addition, all costs and attorney's fees to be paid in full.

AYES: Gore, Rabbitt, Zane, Hopkins

ABSENT: Gorin

22. [The Board of Supervisors, the Board of Directors of the Water Agency, the Board Commissioners of the Community Development Commission, and the Board of Directors of The Agricultural Preservation and Open Space District will consider the following in closed session: Conference with Labor Negotiators: Christina Cramer/Carol Allen, County of Sonoma, and Rick Bolanos/Heather Coffman, Liebert Cassidy & Whitmore. Employee Organizations: All. Unrepresented employees: All, including retired employees. \(Government Code section 54957.6\).](#)

No reportable action. Direction was given to labor negotiators.

VII. [REGULAR AFTERNOON CALENDAR](#)

VIII. [1:46 P.M. - PRESENTATIONS/GOLD RESOLUTIONS](#)

23. [3:55 P.M. RECONVENE FROM CLOSED SESSION](#)

Supervisors Present: James Gore, David Rabbitt, Shirlee Zane, Lynda Hopkins

Supervisors Absent: Susan Gorin

Staff Present: Sheryl Bratton, County Administrator and Bruce Goldstein, County Counsel

24. [REPORT ON CLOSED SESSION](#)

County Counsel Bruce Goldstein reported on Closed Session Items 21 and 22.

BOARD OF SUPERVISORS

25. Municipal Advisory Councils and Citizen's Advisory Councils Update and Recommendations:

- A) Accept an update on the status of Municipal and Citizens Advisory Councils in Sonoma County.
- B) Adopt a Resolution to establish the Lower Russian River Municipal Advisory Council, boundaries, and rules and procedures for governance as indicated in the Lower Russian River Municipal Advisory Council Bylaws, and the Sonoma County Municipal Advisory Council Policies & Procedures.
- C) Adopt a Resolution to establish the Sonoma County Coast Municipal Advisory Council, boundaries, and rules and procedures for governance as indicated in the Sonoma County Coast Municipal Advisory Council Bylaws, and the Sonoma County Municipal Advisory Council Policies & Procedures.
- D) Direct staff to include options for the Board of Supervisors to fund ongoing costs of Municipal Advisory Councils in the Transient Occupancy Tax discussion planned for November.

2:58 P.M.

This item was taken out of order.

Presenters:

Jennifer Larocque, Administrative Analyst, County Administrator's Office
Amie Windsor, Board of Supervisor's Aide, District 5

2:58 P.M. Public Comment Opened

Public Speakers:

Marcy Cooper
Jennifer Wertz
Floyd Walls
Nance Jones

3:06 P.M. Public Comment Closed

Board action: Approved as Recommended

AYES: Rabbitt, Zane, Gore, Hopkins

ABSENT: Gorin

Approved by Resolution 18-0405 and 18-0406

IX. BOARD MEMBER REPORTS ON ASSIGNED BOARDS, COUNCILS, COMMISSIONS OR OTHER ATTENDED MEETINGS

There were no Board Member announcements.

- 26. Permit and Resource Management Department: Review and possible action on the following: Acts and Determinations of Planning Commission/Board of Zoning Adjustments Acts and Determinations of Project Review and Advisory Committee Acts and Determinations of Design Review Committee Acts and Determinations of Landmarks Commission Administrative Determinations of the Director of Permit and Resource Management (All materials related to these actions and determinations can be reviewed at: <http://www.sonoma-county.org/prmd/b-c/index.htm>)

Board Action: None

27. ADJOURNMENT

3:56 P.M.

The Board adjourned the meeting in memory of Siegfried Linkwitz, Harry Friedman, Helen Rudee.

The meeting was adjourned to October 9, 2018 at 8:30 A.M.

Respectfully Submitted,

Kay Lowtrip
Chief Deputy Clerk of the Board

NOTE: The next Regular meeting will be held on October 9, 2018, at 8:30 a.m.

Upcoming Hearings (All dates are tentative until each agenda is finalized)

October 23, 2018 - Permit and Resource Management - PLP05-0062 Hale Winery September 25, 2018 2

**ACTION SUMMARY
COUNTY OF SONOMA
BOARD OF SUPERVISORS
TUESDAY, OCTOBER 2, 2018**

Supervisors Susan Gorin, David Rabbitt, Shirlee Zane, James Gore, Lynda Hopkins
Sheryl Bratton, County Administrator
Bruce Goldstein, County Counsel

8:17 A.M. CALL TO ORDER

Supervisors Present: Susan Gorin, Shirlee Zane, James Gore, Lynda Hopkins

Supervisors Absent: David Rabbitt

Staff Present: Sheryl Bratton, County Administrator and Bruce Goldstein, County Counsel

PLEDGE OF ALLEGIANCE

I. **APPROVAL OF THE AGENDA (Items may be added or withdrawn from the agenda consistent with State law)**

Board Action: Approved as recommended

AYES: Gorin, Zane, Gore, Hopkins

ABSENT: Rabbitt

II. **BOARD MEMBER REPORTS ON ASSIGNED BOARDS, COUNCILS, COMMISSIONS OR OTHER ATTENDED MEETINGS**

8:18 A.M.

Supervisor Hopkins attended the Rural Counties Representatives of California Conference where they voted to approve Sonoma County to join. Supervisor Hopkins is the primary appointee and Supervisor Gore is the alternate. Sonoma County have been invited to be part of the Forest management task force. She also attended a Commission on Human Rights meeting. She attended an Onsite Wastewater Treatment Systems (OWST) meeting as well as a North Bay Coast Broadband Oversight meeting.

Supervisor Gorin listened to last weeks meeting remotely. She also attended the California State Association of Counties (CSAC) regional meeting in Napa. She also spoke of a meeting to discuss the Citizen's Advisory Meeting for the Springs.

Supervisor Zane moderated a panel on the challenges of delivering mental health services at this time to CSAC at the regional conference. Had a meeting with city officials to discuss Community Development Block Grant - Recovery (CDBG) funding.

Supervisor Gore attended the CDBG meeting with City officials and asked Supervisor Zane to announce the 6:00 P.M. Courthouse Square event to mark the anniversary of the fires.

III. **8:39 A.M. - PUBLIC COMMENT ON MATTERS NOT LISTED ON THE AGENDA BUT WITHIN THE SUBJECT MATTER JURISDICTION OF THE BOARD AND ON BOARD MEMBER REPORTS (Comments are restricted to matters within the Board's jurisdiction. The Board will hear public comments at this time for up to thirty minutes. Each person is usually granted time to speak at the discretion of the Chair. Any additional public comments will be heard at the conclusion of the meeting. While members of the public are welcome to address the Board, under the Brown Act, Board members may not deliberate or take action on items not on the agenda.)**

8:39 A.M. Public Comment Opened

Public Speakers:
Michelle Miller
Mary Morrison
Roseanne Snyder
Richard Hannon

8:47 A.M. Supervisor Rabbitt entered the meeting.

Maureen Devoe
Rachel Bell
John Jenkel
Thomas Ells
Annette Elder Evins

8:59 A.M. Public Comment Closed

IV. [PUBLIC COMMENT ON CLOSED SESSION ITEMS](#)

8:59 A.M. Public Comment Opened

Public Speakers:
None

8:59 A.M. Public Comment Closed

V. [CLOSED SESSION CALENDAR](#)

1. [The Board of Supervisors, the Board of Directors of the Water Agency, the Board Commissioners of the Community Development Commission, and the Board of Directors of The Agricultural Preservation and Open Space District will consider the following in closed session: Conference with Labor Negotiators: Christina Cramer/Carol Allen, County of Sonoma, and Rick Bolanos/Heather Coffman, Liebert Cassidy & Whitmore. Employee Organizations: All. Unrepresented employees: All, including retired employees. \(Government Code section 54957.6\).](#)

No reportable action. Direction was given to Counsel and Staff.

2. [RECONVENE FROM CLOSED SESSION](#)

Supervisors Present: Susan Gorin, Shirlee Zane, James Gore, Lynda Hopkins

Supervisors Absent: David Rabbitt

Staff Present: Sheryl Bratton, County Administrator and Bruce Goldstein, County Counsel

3. [REPORT ON CLOSED SESSION](#)

11:23 A.M. County Counsel Bruce Goldstein reported on Closed Session Item 1.

4. [ADJOURNMENT](#)

11:24 A.M. The Board adjourned.

The meeting was adjourned to October 9, 2018 at 8:30 A.M.

Respectfully submitted,

Kay Lowtrip,
Chief Deputy Clerk of the Board

NOTE: The next Regular meeting will be held on October 9, 2018, at 8:30 a.m.
October 2, 2018 2

ACTION SUMMARY
BOARD OF SUPERVISORS
SONOMA COUNTY
575 ADMINISTRATION DRIVE, ROOM 102A
SANTA ROSA, CA 95403

TUESDAY

OCTOBER 9, 2018

8:30 A.M.

Susan Gorin	First District	Sheryl Bratton	County Administrator
David Rabbitt	Second District	Bruce Goldstein	County Counsel
Shirlee Zane	Third District		
James Gore	Fourth District		
Lynda Hopkins	Fifth District		

8:36 A.M. CALL TO ORDER

Supervisors Present: Susan Gorin, David Rabbitt, Shirlee Zane, James Gore, Lynda Hopkins

Staff Present: Christina Rivera, Assistant County Administrator and Bruce Goldstein, County Counsel

PLEDGE OF ALLEGIANCE

- I. [APPROVAL OF THE AGENDA \(Items may be added or withdrawn from the agenda consistent with State law\)](#)

8:37 A.M.

Item 31 A was added to the Agenda via addendum.

Items 23, 24 and 25 were amended.

Board Action:
Approved as Amended
UNANIMOUS VOTE

- II. CONSENT CALENDAR

AGRICULTURAL PRESERVATION AND OPEN SPACE DISTRICT

(Directors: Gorin, Rabbitt, Zane, Gore, Hopkins)

AND

REGIONAL PARKS

1. [Mark West Creek Regional Park & Open Space Preserve \(0530\) Transfer and Acquisition: Approve resolutions of the Board of Directors of the Sonoma County Agricultural Preservation and Open Space District and the Board of Supervisors of the County of Sonoma taking the necessary actions to transfer and acquire properties comprising the Mark West Creek Regional Park & Open Space Preserve subject to a conservation easement and a recreation conservation covenant and making related determinations. \(First and Fourth Districts\)\(4/5th Vote Required\)](#)

Approved as recommended
UNANIMOUS VOTE
Approved by resolutions 18-0407 and 18-0408

**SONOMA COUNTY WATER AGENCY/
OCCIDENTAL COUNTY SANITATION DISTRICT**

(Directors: Gorin, Rabbitt, Zane, Gore, Hopkins)

AND

TRANSPORTATION AND PUBLIC WORKS

2. [Occidental Sewer Force Main Project: Concurrent Actions:](#)

- A) [The Board of Directors of the Occidental County Sanitation District find and determine that the proposed contract with the County of Sonoma to replace the damaged and aging pipeline during the County's Project is the most economical to perform this work and that it is in the best interests of the District and the public; and](#)
- B) [Authorize Sonoma County Water Agency's General Manager acting on behalf of Occidental County Sanitation District, and the Director of County of Sonoma Transportation and Public Works to execute an agreement for County of Sonoma Transportation and Public Works Department to perform sewer force main pipe replacement through December 31, 2018 in the not-to-exceed amount of \\$57,700.](#)
- C) [Adopt a Resolution authorizing adjustments to the Board Adopted Budget for Fiscal Year 2018-2019 for the Occidental County Sanitation District, in the amount of \\$57,700. \(4/5th Vote Required\) \(Fourth District\)](#)

Approved as recommended
UNANIMOUS VOTE
Approved by resolution 18-0409

SONOMA COUNTY WATER AGENCY
(Directors: Gorin, Rabbitt, Zane, Gore, Hopkins)

- 3. [Environmental Systems Research Institute, Inc. - Enterprise Advantage Program and, As-Needed Database and Web Development Services:](#)
 - A) [Authorize Sonoma County Water Agency's General Manager to execute a two-year agreement with Environmental Systems Research Institute, Inc. - Enterprise Advantage Program subscription and support services through approximately October, 2020 in the amount of \\$172,000. The Agreement will provide technical support to deploy a cloud computing environment for Sonoma County Water Agency's Geographic Information Systems data, which will support advanced technical projects, facilitate data sharing with external agencies, and provide secured backup data to improve resiliency and ensure continuity of operations during future disasters.](#)
 - B) [Authorize Sonoma County Water Agency's General Manager to execute the First Amended Agreement for As-Needed Database and Web Development Services with Dina Luvishis to provide Geographic Information Systems database programming and maintenance increasing the amount by \\$180,000, and extending the agreement term by two years for a new not-to-exceed agreement total of \\$230,000 and end date of February 28, 2021.](#)
 - C) [Authorize the Sonoma County Water Agency's General Manager to terminate the agreements in accordance with their respective termination clauses.](#)
 - D) [Adopt a resolution authorizing adjustments to Sonoma County Water Agency's Fiscal Year 2018-2019 adopted budget for the General Fund in the amount of \\$237,000 for Environmental Systems Research Institute, Inc. - Enterprise Advantage Program. \(4/5th Vote Required\)](#)

Approved as recommended
UNANIMOUS VOTE
Approved by resolutions 18-0410

- 4. [2018 Local Hazard Mitigation Plan: Adopt a Resolution approving the Sonoma County Water Agency 2018 Local Hazard Mitigation Plan, which will help prepare for natural and other disasters by identifying physical vulnerabilities and developing strategies to alleviate their impacts. The preparation, approval, and adoption of the Plan are required in order to obtain Federal Emergency Management Agency funds.](#)

Approved as recommended
UNANIMOUS VOTE
Approved by resolution 18-0411

- 5. [Warm Springs Hydropower Non-Disclosure Agreement:](#)
 - A) [Authorize the Sonoma County Water Agency's General Manager to execute a Non-Disclosure Agreement with Sonoma Clean Power to enable confidential discussions and negotiations between the parties regarding the potential](#)

sale of power from the Agency’s Warm Springs Dam Hydroelectric Power Facility. Selling hydroelectric power to Sonoma Clean Power would increase revenues and allow local renewables to benefit the community.

- B) Authorize the Sonoma County Water Agency’s General Manager to terminate the Agreement, if appropriate. (Fourth District)

Approved as recommended
UNANIMOUS VOTE

COUNTY ADMINISTRATOR

- 6. Recovery Update: Receive an update on the status of recovery operations, planning, seeking of funding opportunities, community engagement and status of recovery framework, following the October 2017 Sonoma Complex Fires.

Approved as recommended
UNANIMOUS VOTE

GENERAL SERVICES/HEALTH SERVICES

- 7. Lease Renewal for the Department of Health Services at 625 5th Street, Santa Rosa: Authorize the General Services Director to execute a lease renewal with Sonoma Commercial Investors L.P. as Landlord for 38,473 rentable square feet of office space at 625 5th Street, Santa Rosa, for a term of 6 years: rental payment of \$72,137 per month for the first three-years (\$865,644 per year), and tenant improvements completed by the landlord, in support of saving the Department of Health Services’ Public Health Division an estimated \$1,554,935 over the 6 year lease term (2nd action).

Approved as recommended
UNANIMOUS VOTE

HUMAN RESOURCES

AND

SONOMA COUNTY WATER AGENCY

(Directors: Gorin, Rabbitt, Zane, Gore, Hopkins)

- 8. Additional negotiated provisions of the Memorandum of Understanding as part of the extension between the County of Sonoma and the International Union of Operating Engineers, Stationary Engineers, Local No. 39 (Local 39): Adopt a Concurrent Resolution approving additional negotiated provisions to the one-year extension to the Memorandum of Understanding (MOU) between the County of Sonoma and the International Union of Operating Engineers, Stationary Engineers, Local No. 39 (Local 39) for the period of July 2, 2018 through July 1, 2019.

Approved as recommended
UNANIMOUS VOTE
Approved by resolution 18-0412

PERMIT AND RESOURCE MANAGEMENT

- 9. Issue a roiling permit (Ordinance No. 3836R) to Christopher McCook; ROI18-0006: Adopt a resolution issuing a roiling permit (Ordinance No. 3836R) to Christopher McCook for emergency bank repair along the bank of the Russian River below his private residence located at 21786 Moscow Road in the Town of Monte Rio. (4/5th Vote Required) (Fifth District)

Approved as recommended
UNANIMOUS VOTE
Approved by resolution 18-0413

REGIONAL PARKS

- 10. Cannon Lane Improvements:

- A) [Approve specifications, plans, design and forms for the construction of the Cannon Lane – Road Improvements project.](#)
- B) [Award the Construction for the Cannon Lane – Road Improvements project for overlay paving work for maintenance and safety. To improve paving conditions on Cannon Lane as described in the base bid, additive alternative 1, and additive alternative 2, to Pat Nelson Construction, in the amount of \\$302,308.00. \(Second District\)](#)

Approved as recommended
UNANIMOUS VOTE

- 11. [Lower Russian River Trail Feasibility Study – Award Consultant Contract: Authorize Chairperson of the Board of Supervisors to execute a professional service agreement in the amount of \\$664,038 with Alta Planning + Design, Inc. to prepare the Lower Russian River Trail Feasibility Study. \(Fifth District\)](#)

Approved as recommended
UNANIMOUS VOTE

TRANSPORTATION AND PUBLIC WORKS

- 12. [FY 2019 SB1 State of Good Repair Grant Program: Adopt a resolution approving the SB1 State of Good Repair Project List for Fiscal Year 2018-19 for the County of Sonoma/Sonoma County Transit.](#)

Approved as recommended
UNANIMOUS VOTE
Approved by resolution 18-0414

APPOINTMENTS/REAPPOINTMENTS

- 13. [Approve the appointment of Tim Zahner to the Sonoma County Tourism Board, effective October 9, 2018 and expiring on October 9, 2019. \(First District\)](#)

Approved as recommended
UNANIMOUS VOTE

- 14. [Approve the appointment of Tamara Murrell to the Commission on Human Rights for a two year term beginning on October 1, 2018 and ending on October 1, 2020. \(Fifth District\)](#)

Approved as recommended
UNANIMOUS VOTE

- 15. [Approve the reappointment of Karissa Kruse to the Sonoma County Tourism Board for a two year term beginning June 30, 2018 and ending June 30, 2020. \(Fifth District\)](#)

Approved as recommended
UNANIMOUS VOTE

- 16. [Approve the reappointment of Jessica Wood to the Commission on the Status of Women for a two-year term beginning on October 9, 2018 and ending on October 9, 2020. \(Fifth District\)](#)

Approved as recommended
UNANIMOUS VOTE

PRESENTATIONS/GOLD RESOLUTIONS

PRESENTATIONS AT THE BOARD MEETING

(Item 17 will be presented at 8:45 A.M., items 18 through 21 will be presented at 1:30 P.M) PRESENTATION AT 8:45 A.M. (Item 17)

17. [Adopt a Gold Resolution in appreciation of State and Federal Representative support of Sonoma County's disaster response and recovery efforts from the Sonoma Complex Fires of 2017. \(County Administrator\)](#)

Approved as recommended
UNANIMOUS VOTE
Approved by resolution 18-0415

PRESENTATIONS AT 1:30 P.M.

(Items 18 through 21)

18. [Adopt a Gold Resolution Commending KSRO for Outstanding Public Service and News Coverage of the 2017 Sonoma Complex Fires. \(First District\)](#)

Approved as recommended
UNANIMOUS VOTE
Approved by resolution 18-0416

19. [Approve Gold Resolution Declaring October 9 through October 31 as Binational Health Care week. \(Fourth District\)](#)

Approved as recommended
UNANIMOUS VOTE
Approved by resolution 18-0417

20. [Adopt a Gold Resolution proclaiming October 7-13, 2018, as Fire Prevention Week in Sonoma County. \(Fire and Emergency Services\)](#)

Approved as recommended
UNANIMOUS VOTE
Approved by resolution 18-0418

21. [Adopt a Gold Resolution proclaiming October 2018 to be Domestic Violence Awareness Month in Sonoma County. \(District Attorney, Probation, Sheriff's Office, Health Services, Human Resources – Commission on the Status of Women, Human Services\)](#)

Approved as recommended
UNANIMOUS VOTE
Approved by resolution 18-0419

PRESENTATIONS ON A DIFFERENT DATE

22. [Adopt a gold resolution proclaiming October 7 to October 13, 2018 as Mental Health Awareness Week in Sonoma County. \(Health Services\)](#)

8:52 A.M. Public comment opened

Public Speakers:
Duane Dewitt
Laurie Laman
Bill Cresta
Thomas Ells

9:02 A.M. Public comment closed

Approved as recommended
UNANIMOUS VOTE
Approved by resolution 18-0420

III. [9:04 A.M. - PRESENTATIONS/GOLD RESOLUTIONS](#)

- IV. [9:18 A.M. - PUBLIC COMMENT ON MATTERS NOT LISTED ON THE AGENDA BUT WITHIN THE SUBJECT MATTER JURISDICTION OF THE BOARD AND ON BOARD MEMBER REPORTS \(Comments are restricted to matters within the Board’s jurisdiction. The Board will hear public comments at this time for up to thirty minutes. Each person is usually granted time to speak at the discretion of the Chair. Any additional public comments will be heard at the conclusion of the meeting. While members of the public are welcome to address the Board, under the Brown Act, Board members may not deliberate or take action on items not on the agenda.\)](#)

9:18 A.M. Public comment opened

Public Speakers:

Duane Dewitt
Joel Evans - Fudem
Laura Alexander
Amanda Erlendson
Rachell Lynch
William Abrams
Michelle Miller
Mary Morrison
Maureen DeVox
Shelby Crosby
Rachel Bell
James Savage
Richard Hannon
John Jenkel
Thomas Ells

10:01 A.M. Public comment closed

- V. REGULAR CALENDAR

HUMAN RESOURCES

23. [Approval of Article 19 – Medical Benefits for Future Retirees – in the 2018/2019 Memorandum of Understanding between the County of Sonoma and the Sonoma County Law Enforcement Association: Adopt a Resolution approving Article 19 – Medical Benefits for Future Retirees – that was negotiated as part of the 2018/2019 Memorandum of Understanding \(“MOU”\) between the County of Sonoma and the Sonoma County Law Enforcement Association.](#)

10:01 A.M. This item was heard along with Items 24 and 25.

Presenters:

Marcia Chadbourne, Risk Manager, Human Resources
Harold Cooper, Seagle Consulting

10:07 A.M. Public comment opened

Public Speakers:

None

10:07 A.M. Public comment closed

Approved as amended
UNANIMOUS VOTE
Approved by resolution 18-0421

24. [Approval of Article 16 – Medical Benefits for Future Retirees – in the 2018/2019 Memorandum of Understanding between the County of Sonoma and the Sonoma County Public Defender Investigator’s Association: Adopt a resolution approving Article 16 of the extension to the Memorandum of Understanding \(“MOU”\) between the County of Sonoma and the Sonoma County Public Defender Investigator’s Association.](#)

10:01 A.M. This item was heard along with Items 23 and 25.

Presenters:

Marcia Chadbourne, Risk Manager, Human Resources

Harold Cooper, Seagle Consulting

10:07 A.M. Public comment opened

Public Speakers:

None

10:07 A.M. Public comment closed

Approved as amended

UNANIMOUS VOTE

Approved by resolution 18-0422

25. [Approval of Article 6 - Medical Benefits for Future Retirees - of the Memorandum of Understanding between the County of Sonoma and the Sonoma County Law Enforcement Management Association: Adopt a Resolution approving Article 6 – Medical Benefits for Future Retirees – that was negotiated as part of the 2018/2019 Memorandum of Understanding \(“MOU”\) between the County of Sonoma and the Sonoma County Law Enforcement Management Association.](#)

10:01 A.M. This item was heard along with Items 23 and 24.

Presenters:

Marcia Chadbourne, Risk Manager, Human Resources

Harold Cooper, Seagle Consulting

10:07 A.M. Public comment opened

Public Speakers:

None

10:07 A.M. Public comment closed

Approved as amended

UNANIMOUS VOTE

Approved by resolution 18-0423

REGIONAL PARKS

26. [Tolay Lake Regional Park Master Plan and Environmental Impact Report: Hold a public hearing and Adopt a Resolution that:](#)
- A) [Certifies the Final Environmental Impact Report for the Tolay Lake Regional Park Master Plan;](#)
 - B) [Adopts a statement of overriding considerations for the project;](#)
 - C) [Approves the Tolay Lake Regional Park Master Plan;](#)
 - D) [Amends the General Plan land use designation and zoning of the eight \(8\) park parcels from LEA \(Land Extensive Agriculture\) and LIA \(Land Intensive Agriculture\) to PQP \(Public Quasi Public\) and PF \(Public Facilities\), respectively; and](#)
 - E) [Designates the park property as an “Existing Park” on the General Plan Open Space maps.](#)

- F) [Extend the Memorandum of Agreement \(MOA\) for the Tolay Lake Regional Park Master Plan and Environmental Review Process Between the County of Sonoma and the Federated Indians of Graton Rancheria \(FIGR\), to October 9, 2019. \(Second District\)](#)

10:10 A.M.

Presenters:

Bert Whitaker, Regional Parks Director, Regional Parks
Steve Ehret, Regional Park Planning Manager, Regional Parks
Karen Davis-Brown, Regional Parks Planner II, Regional Parks
John Baas, MIG Project Manager

10:30 A.M. Supervisor Zane exited the meeting.

10:48 A.M. Public comment opened

Public Speakers:

Melissa Kelley
Ken Wells
Dave Koehler
Greg Colvin
Laurel Ross

10:58 A.M. Public comment closed

Approved as recommended

AYES: Gorin, Rabbitt, Gore, Hopkins

ABSENT: Zane

Approved by resolution 18-0424

COMMUNITY DEVELOPMENT COMMISSION

(Directors: Gorin, Rabbitt, Zane, Gore, Hopkins)

27. [11:49 A.M. - Homeless Update and System Redesign:](#)

- A) [Authorize the Homeless System Redesign Plan and formation of the new Leadership Council and Technical Advisory Committee \(TAC\) of the new Sonoma County Homeless System of Care, the HUD-mandated Continuum of Care Program for Sonoma County.](#)
- B) [Authorize and appoint two members of the Sonoma County Board of Supervisors to the nine-member Leadership Council of the Sonoma County Homeless System of Care.](#)
- C) [Authorize the revised Declaration of Shelter Crisis for Sonoma County to receive State Homeless Emergency Aid Program funding and rescind the July 10th, 2018 Declaration.](#)
- D) [Authorize the Sonoma County Community Development Commission as the Administrative Entity designated by the Sonoma County Continuum of Care to apply for and receive California Emergency Solutions and Housing Program \(CESH\) funds. \(4/5th Vote Required\)](#)

11:49 A.M. The Board reconvened. Supervisor Zane returned to the meeting.

Presenters:

Geoffrey Ross, Assistant Executive Director, Community Development Commission
Jenny Abramson, Homeless and Community Services Manager; Community Development Commission
Michael Gause, Continuum of Care Coordinator, Community Development Commission

12:17 P.M. Public comment opened

Public Speakers:

Kathleen Finegan
Kear Koch
Scott Wagner
Thomas Ells

12:30 P.M. Public comment closed

Board Action:

Approved as amended

The Board authorized and appointed Supervisors Gorin and Hopkins to the Leadership Council of the Sonoma County Homeless System of Care.

UNANIMOUS VOTE

Approved by resolutions 18-0425 and 18-0426

VI. [PUBLIC COMMENT ON CLOSED SESSION ITEMS](#)

11:03 A.M. Public comment opened

Public Speakers:

None

11:03 A.M. Public comment closed

VII. [CLOSED SESSION CALENDAR](#)

1:36 P.M. County Counsel Bruce Goldstein reported on Closed Session Items 28 through 31A.

28. [The Board of Directors of the Agricultural Preservation and Open Space District will consider the following in closed session: Conference with Legal Counsel – Potential initiation of litigation pursuant to Government Code section 54956.9\(d\)\(4\) \(1 matter\).](#)

The Agricultural Preservation and Open Space District Board authorized the Open Space District to initiate litigation to enforce a conservation easement regarding the property located at 4871 Redwood Highway, Petaluma.

UNANIMOUS VOTE

29. [The Board of Supervisors will consider the following in closed session: Conference with Legal Counsel – Anticipated Litigation. Potential initiation of litigation pursuant to Government Code section 54956.9\(d\)\(4\). 6 Potential Cases.](#)

The Board of Supervisors authorized the initiation of abatement litigation to remove hazardous materials against the property located at 4300 Porter Creek Rd., Santa Rosa.

UNANIMOUS VOTE

30. [The Board of Supervisors will consider the following in closed session: Conference with Legal Counsel – Existing Litigation – County of Sonoma v. Rosemary Jensen; Sonoma County Superior Court Case No. SCV 258993 \(Government Code Section 54956.9\(d\)\(1\).\)](#)

This item was withdrawn.

31. [The Board of Supervisors, the Board of Directors of the Water Agency, the Board Commissioners of the Community Development Commission, and the Board of Directors of The Agricultural Preservation and Open Space District will consider the following in closed session: Conference with Labor Negotiators: Christina Cramer/Carol Allen, County of Sonoma, and Rick Bolanos/Heather Coffman, Liebert Cassidy & Whitmore. Employee Organizations: All. Unrepresented employees: All, including retired employees. \(Government Code section 54957.6\).](#)

This item was withdrawn.

- 31a. [The Board of Supervisors will consider the following in closed session: Conference with Real Property Negotiator - Sonoma Development Center, 15000 Arnold Drive, Eldridge, CA. \(APNs- 054-080-001, 054-090-001, 054-150-005, 054-150-010\) Negotiating parties: For County- Caroline Judy, general Services Director. For State- Gerald McLaughlin, California Department of general Services. Under Negotiation: Terms and conditions of the potential acquisition of the Property. \(Government Code Section 54956.8.\)](#)

No reportable action. Direction was given to counsel and staff.

VIII. [REGULAR AFTERNOON CALENDAR](#)

32. [RECONVENE FROM CLOSED SESSION](#)

Supervisors Present: Susan Gorin, David Rabbitt, Shirlee Zane, James Gore, Lynda Hopkins

Staff Present: Christina Rivera, Assistant County Administrator and Bruce Goldstein, County Counsel

33. [REPORT ON CLOSED SESSION](#)

1:36 P.M. County Counsel Bruce Goldstein reported on Closed Session Items 28 through 31A.

IX. [1:37 P.M. - PRESENTATIONS/GOLD RESOLUTIONS](#)

GENERAL SERVICES/COUNTY COUNSEL

AND

AGRICULTURAL PRESERVATION AND OPEN SPACE DISTRICT/ SONOMA COUNTY WATER AGENCY

(Directors: Gorin, Rabbitt, Zane, Gore, Hopkins)

34. [Introduction of Ordinance Vacating Approval of the Chanate Campus Development and Disposition Agreement By Rescinding Ordinance No. 6205:](#)
- A) [Adopt a Resolution reading title of and waiving further reading of the proposed ordinance;](#)
 - B) [Introduce Ordinance Rescinding Ordinance No. 6205 and vacating the approval of the Development and Disposition Agreement to sell the Chanate Campus to Chanate Community Development Partners, LLC \(first reading\);](#)
 - C) [Consider options for and provide direction to Staff on the future of the Chanate Campus including: \(i\) completing an environmental review and re-entering a new Development and Disposition Agreement to sell the Chanate Campus to Chanate Community Development Partners, LLC; \(ii\) engaging in a new surplus process to sell the Chanate Campus; and \(iii\) exploring options to combine disposition of the Chanate Campus with the facility planning process for the County Government Center.](#)
 - D) [Direct staff to explore ways to protect Parcel J as an open space resource. \(4/5th Vote Required\)](#)

2:20 P.M.

Presenters:

Caroline Judy, Director, General Services

Robert Pittman, Assistant County Counsel

2:53 P.M. Public comment opened

Public Speakers:

Duane Dewitt

Joseph Zills

Kelly McManus

Jan Bolt

Chris Knepper

Tim Stafford

Michael Hilbur
Charles Metz
Carol
Jeremy Nichols
Phillip Lowell
Annita Brock
Mike O'Neal
Jeffery Corone

3:21 P.M. Public comment closed

Board Action:

Approved as Amended:

1. Adopted Resolution No. 18-0427, a Concurrent Resolution Of The Board Of Supervisors Of The County Of Sonoma, State Of California (County), The Board Of Directors Of The Sonoma County Agricultural Preservation And Open Space District (District), And The Board Of Directors Of The Sonoma County Water Agency (Water Agency) Reading the Title Of and Waiving Further Reading of Ordinance;
2. Introduced Ordinance, An Ordinance Of The Board Of Supervisors Of The County Of Sonoma, State Of California (County), The Board Of Directors Of The Sonoma County Agricultural Preservation And Open Space District (District), And The Board Of Directors Of The Sonoma County Water Agency (Water Agency) Rescinding And Vacating Ordinance No. 6205, Previously Adopted On July 11, 2017, As Ordered By The Superior Court In Sonoma County Court Case No. Scv-261103;
3. Directed staff to explore ways to protect Parcel J and the additional parcels comprising the “Paulin Creek Preserve” as an open space resource and return to the Board with a proposed plan;
4. Directed staff to permanently protect the rural cemetery on the Chanate campus; and
5. Directed staff to engaging in a new surplus process to sell the Chanate Campus—either as a single, cohesive property or, alternatively, to separately sell the individual parcels that comprise the campus provided the County receives offers to purchase all of the parcels being surplus—and excluding Parcel J, the rural cemetery, and any additional land necessary for the uses the County will continue on the Chanate campus.

Approved by Resolution 18-0427

UNANIMOUS VOTE

X. [BOARD MEMBER REPORTS ON ASSIGNED BOARDS, COUNCILS, COMMISSIONS OR OTHER ATTENDED MEETINGS](#)

There were no Board Member announcements.

35. [Permit and Resource Management Department: Review and possible action on the following: Acts and Determinations of Planning Commission/Board of Zoning Adjustments Acts and Determinations of Project Review and Advisory Committee Acts and Determinations of Design Review Committee Acts and Determinations of Landmarks Commission Administrative Determinations of the Director of Permit and Resource Management \(All materials related to these actions and determinations can be reviewed at: <http://www.sonoma-county.org/prmd/b-c/index.htm>\)](#)

4:11 P.M.

Board Action:

The Board approved the Acts and Determinations.

UNANIMOUS VOTE

36. [ADJOURNMENT](#)

4:12 P.M. The Board adjourned the meeting in the memory of Willy Benedetti, Patrick Foley, and Shery Anita Adams.

The meeting was adjourned to October 16, 2018, at 8:30 A.M.

Respectfully submitted, Kay Lowtrip, Chief Deputy Clerk of the Board

NOTE: The next Regular meeting will be held on October 16, 2018, at 8:30 a.m.

Upcoming Hearings (All dates are tentative until each agenda is finalized)

October 16, 2018 - Permit and Resource Management – Roblar Road Quarry, File UPE16-0058
October 16, 2018 - Permit and Resource Management – Cannabis Ordinance Amendments
October 23, 2018 - Permit and Resource Management – PLP05-0062 Hale Winery
October 9, 2018 9

ACTION SUMMARY
BOARD OF SUPERVISORS
SONOMA COUNTY
575 ADMINISTRATION DRIVE, ROOM 102A
SANTA ROSA, CA 95403

TUESDAY

OCTOBER 16, 2018

8:30 A.M.

Susan Gorin	First District	Sheryl Bratton	County Administrator
David Rabbitt	Second District	Bruce Goldstein	County Counsel
Shirlee Zane	Third District		
James Gore	Fourth District		
Lynda Hopkins	Fifth District		

8:32 A.M. CALL TO ORDER

Supervisors Present: Susan Gorin, David Rabbitt, Shirlee Zane, James Gore, Lynda Hopkins

Staff Present: Sheryl Bratton, County Administrator and Bruce Goldstein, County Counsel

PLEDGE OF ALLEGIANCE

- I. [APPROVAL OF THE AGENDA](#)
[\(Items may be added or withdrawn from the agenda consistent with State law\)](#)

The Chair announced that there had been an agenda addendum posted to add item 32a to the agenda, and to continue it to the October 23, 2018 meeting.

He also announced that item 5 was continued to the October 23, 2018 meeting.

The Chair read a correction into the record on item 3, Citizen's Advisory Councils Recommendations and Authorization to Repurpose Certain Franchise Fees stating that as written, the item requests the Auditor-Controller-Treasurer-Tax Collector to move funds into a Neighborhood Improvement Fund, when in fact, ACTTC will disperse the funds through the Neighborhood Improvement Program.

Board action: Approved as Amended
UNANIMOUS VOTE

- II. [CONSENT CALENDAR](#)

COMMUNITY DEVELOPMENT COMMISSION
(Commissioners: Gorin, Rabbitt, Zane, Gore, Hopkins)

1. [Funding Agreement for Critical Homeless Service System Infrastructure: the Homeless Outreach Service Team, the Coordinated Entry Project, and Homelessness Diversion Project: Authorize the Executive Director or her designee to execute a Funding Agreement with Catholic Charities of the Diocese of Santa Rosa, for continued operations of the Homeless Outreach Service Team Field Work Team, the Coordinated Entry Program, and the Homelessness Diversion Project in the amount of \\$660,914 for the period July 1, 2018-June 30, 2019.](#)

Board action: Approved as Recommended
UNANIMOUS VOTE

BOARD OF SUPERVISORS

2. [Disbursement of Fiscal Year 2018-2019 1st District Community Investment Fund Grant Awards: Approve Community Investment Fund grant awards and Authorize the County Administrator, or designee, to execute an agreement with the following non-profit entities for advertising and economic development efforts for FY 2018-2019: Santa Rosa Players DBA 6th Street Playhouse, \\$500; Community Action Partnership of Sonoma County for "Rising from the Ashes- Through Community Action" event, \\$500; Los Cien Sonoma County Inc., \\$500; Sonoma Valley Vintners & Growers](#)

Association DBA Sonoma Valley Vintners and Growers Alliance for “2019 Signature Sonoma Valley” event, \$3,500. (First District)

Board action: Approved as Recommended
UNANIMOUS VOTE

3. Citizen’s Advisory Councils Update and Recommendations and Authorization to Repurpose Certain Franchise Fees for Neighborhood Improvement Projects in the Mark West Area:
 - A) Adopt a resolution authorizing the repurposing of the California American Water Company franchise fees to fund neighborhood improvement projects in the Mark West Area
 - B) Adopt a resolution modifying the Mark West Citizens Advisory Council’s Blue Book to include additional advisory authority as needed by the district supervisor and the process of applying for and awarding funds from the California American Water Franchise Fee budget for neighborhood improvement projects.
 - C) Adopt a resolution amending the Dry Creek Valley Citizens Advisory Council’s Blue Book to include additional advisory authority as needed by the district supervisor and to provide guidance for the Council’s conversations when discussing new use permits that include visitor serving agricultural uses, to facilitate the Council’s advisory recommendations to the Sonoma County Board of Supervisors and its Permit and Resource Management Department, Board of Zoning Adjustments, Planning Commission. (Fourth District)

Board action: Approved as Amended
UNANIMOUS VOTE
Approved by Resolutions 18-0428, 18-0429 and 18-0430

COUNTY ADMINISTRATOR

4. Recovery Update: Receive update on the status of recovery operations, planning, seeking of funding opportunities, community engagement and status of recovery framework.

Board action: Approved as Recommended
UNANIMOUS VOTE

COUNTY ADMINISTRATOR/COUNTY COUNSEL

5. Amendment to Intergovernmental Mitigation Agreement with Federated Indians of Graton Rancheria: Authorize the Chair to execute Amendment No. 1 to the 2012 Intergovernmental Mitigation Agreement with the Federated Indians of Graton Rancheria including the enforcement of Mitigation Measures identified in the Final Tribal Environmental Impact Report and dispute resolutions. (Second District)

This item was continued to October 23, 2018

GENERAL SERVICES/HEALTH SERVICES

6. License Agreements with Goodwill Industries and Santa Rosa Community Health for offices at 2245 and 2235 Challenger Way, Santa Rosa (The Lakes); and Drug Abuse Alternatives Center for offices at 1430 Neotomas (Orenda Center):
 - A) Authorize the General Services Director to execute the following license agreements that enable efficient one-stop client services at existing Department of Health Services locations in Santa Rosa:
 - i. license agreement with Goodwill Industries of the Redwood Empire, Inc., for use of 6,635 sq. ft. of office space at 2245 Challenger Way, Suite 104, Santa Rosa, for a term through June 30, 2020; and to execute future amendments and associated documents; and

- ii. [license agreement with Santa Rosa Community Health, for use of 1,131 sq. ft. of office space, located at 2235 Challenger Way, Suite 109, Santa Rosa, for a term through June 30, 2020; and to execute future amendments and associated documents.](#)
- B) [Authorize the General Services Director to execute a license amendment with Drug Abuse Alternatives Center, for use of 5,060 sq. ft. of office space, located at 1430 Neotomas Avenue, Santa Rosa, for an extended term through August 3, 2020; and to execute future amendments and associated documents; to allow for the continuation of substance use disorder treatment services at the Orenda Center facility.](#)
- C) [Make findings as required by Government Code Section 26227, that the proposed license agreements are necessary to meet the social needs of the population of the County, and that the County does not need the proposed Premises during the term of the license agreements.](#)

Board action: Approved as Recommended
UNANIMOUS VOTE

GENERAL SERVICES

- 7. [Award of Annual Job Order Contracts:](#)
 - A) [Authorize the Chair to execute Job Order Contracts with the following contractors for the minimum and maximum amounts indicated in order to expedite as-needed capital construction and repairs to County-owned properties:](#)
 - i. [Danco Builders Northwest: Minimum Contract Amount,\\$25,000, Maximum Contract Amount \\$1,500,000](#)
 - ii. [Staples Construction Company Inc.: Minimum Contract Amount, \\$25,000, Maximum Contract Amount, \\$1,500,000](#)
 - iii. [T. McFarlin, Inc. dba Bay West Construction: Minimum Contract Amount, \\$25,000, Maximum Contract Amount, \\$1,000,000.](#)
 - iv. [A.E. Nelson Construction: Minimum Contract Amount, \\$25,000, Maximum Contract Amount, \\$1,000,000](#)
 - v. [REM Construction Incorporated: Minimum Contract Amount, \\$25,000, Maximum Contract Amount, \\$500,000. The contract "term" for all of the above will be for one year from the effective date of Notice to Proceed or when Job Orders totaling the maximum contract amount have been completed, whichever occurs first.](#)
 - B) [Adopt a resolution delegating the authority to issue and execute individual Job Orders under the above Job Order Contracts for qualified projects as follows:](#)
 - i. [Deputy Director of Facilities Development and Management or Senior Capital Projects Manager, not to exceed \\$125,000;](#)
 - ii. [General Services Director, not to exceed \\$250,000; and](#)
 - iii. [County Administrator, up to the contractor's remaining Maximum Contract Amount.](#)

Board action: Approved as Recommended
UNANIMOUS VOTE
Approved by Resolution 18-0432

- 8. [Grant of Sewer Easement to City of Santa Rosa/Vacation of Public Utilities and Road Easements: Adopt a Resolution to:](#)
 - A) [Authorize the Director of General Services to execute an easement deed in favor of City of Santa Rosa for existing public sanitary sewer facilities on, over and across County lands, and the right to construct, improve, maintain, repair](#)

and replace said existing facilities. The easement area is approximately 15 ft. wide and 600 ft. long, is more particularly depicted at the attached easement description "Exhibit A Public Sanitary Sewer Easement Over the Lands of the County of Sonoma", and is generally located at the intersection of Russell Ave and Hwy 101, and extending in a southerly direction.

- B) Authorize the Director of General Services to execute any and all documents and instruments, including without limitation deeds and Certificate(s) of Acceptance, necessary to effectuate the vacation of certain City-held utilities and road easements which are either obsolete, no longer used by the City or need to be relocated to accommodate the County's construction of the proposed Adult Detention Behavioral Health Unit (ADBHU) (which will be connected to the Main Adult Detention Facility (MADF)). (Third District)

Board action: Approved as Recommended
UNANIMOUS VOTE

HEALTH SERVICES/COUNTY COUNSEL

9. First 5 Sonoma County Commission Legal Services Agreement with Remcho, Johansen & Purcell, LLP: Authorize County Counsel to execute an agreement with Remcho, Johansen & Purcell, LLP to provide independent legal services focusing on an analysis and interpretation of statutory provisions for the First 5 Sonoma County Commission's status as a public entity and the implications with regard to long-term sustainability in the face of declining Proposition 10 revenue for the period of July 1, 2018 to June 30, 2019 in an amount not-to-exceed \$18,000.

Board action: Approved as Recommended
UNANIMOUS VOTE

HUMAN SERVICES

10. Human Services Revenue Standard Agreements for Medicare Improvements for Patients and Providers Act (MIPPA) and Supplemental Nutrition Assistance Program Education (SNAP-Ed):
- A) Adopt a resolution authorizing the Director of Human Services to execute the Medicare Improvement for Patients and Providers Act (MIPPA) Agreement MI-1819-27 with the California Department of Aging to accept \$120,332 in revenue to fund Medicare support services for seniors and future changes to revenue.
- B) Adopt a resolution authorizing the Director of Human Services to execute the Supplemental Nutrition Assistance Program Education (SNAP-ED) Agreement SP-1819-27 with the California Department of Aging to accept \$97,295 in revenue to fund obesity prevention for seniors and future changes to revenue.

Board action: Approved as Recommended
UNANIMOUS VOTE
Approved by Resolutions 18-0433 and 18-0434

11. Human Services Contract Amendments: Authorize the Director of Human Services to execute contract amendments to include additional funding for FY18/19 to increase funding for the Council on Aging, Petaluma People Services Center, and Senior Advocacy Services.

Board action: Approved as Recommended
UNANIMOUS VOTE

12. Caltrans- Federal Transportation Authority 5310 Older Adults Transportation Funding Award: Authorize the Director of Human Services to execute 4 funding Agreements between the California Department of Transportation and the Human Services Department, Area Agency on Aging for activities serving Older Adults and Individuals with Disabilities, including Transportation Services and Mobility Management Activities, for a total amount of \$659,780 and to execute future amendments to adjust for revenue changes.

Board action: Approved as Recommended
UNANIMOUS VOTE

PERMIT AND RESOURCE MANAGEMENT

13. [Land Conservation Act Contract Replacement; Shelton-Mackenzie Land, LLC; Adopt a resolution to approve the requested Prime Land Conservation Act contract replacements and attached Land Conservation Plans for two parcels, 11.86 acres and 10.84 acres in size, located at 421 West North Street, Healdsburg; APNs 089-140-019 -020, -021, and -022; Permit Sonoma File No. PLP17-0016; Supervisorial District 4. \(Fourth District\)](#)

Board action: Approved as Recommended
UNANIMOUS VOTE
Approved by Resolution 18-0435

TRANSPORTATION AND PUBLIC WORKS

14. [2018 Hazard Tree Removal Project – Road Right-of-Way Trees, Project # M11719:](#)
 - A) [Approve the plans and specifications for 2018 Hazard Tree Removal Project – Public Trees M11719.](#)
 - B) [Award contract to low bidder, Richard Smith, doing business as Bay Area Tree Specialists, in the amount of \\$1,099,825, plus a 10% contingency, and authorize the Chair to execute construction contract M11719. \(First and Fourth Districts\)](#)

Board action: Approved as Recommended
UNANIMOUS VOTE

APPOINTMENTS/REAPPOINTMENTS

15. [Approve the appointment of Caitlin Quinn to the Commission on the Status of Women on October 16, 2018 for a two year term ending October 16, 2020. \(Second District\)](#)

Board action: Approved as Recommended
UNANIMOUS VOTE

PRESENTATIONS/GOLD RESOLUTIONS

(Gold resolutions are presented in the afternoon session at 1:30 P.M.)

16. [Adopt a Gold Resolution recognizing National Disability Employment Awareness Month, October 2018. \(Third District\) PRESENTATION ON A DIFFERENT DATE](#)

Board action: Approved as Recommended
UNANIMOUS VOTE
Approved by Resolution 18-0436

17. [Adopt a Gold Resolution Honoring 10,000 Degrees Fellowship Program as the recipient of the North Bay Leadership Council's 2018 Leaders of the North Bay Award: Empowering the Latino Community, Leadership within the Latino Community. \(Third District\)](#)

Board action: Approved as Recommended
UNANIMOUS VOTE
Approved by Resolution 18-0437

18. [Adopt a Gold Resolution Honoring the Planning & Economic Development Department for the City of Santa Rosa as the recipient of the North Bay Leadership Council's 2018 Leaders of the North Bay Award: From Red Tape to Red Carpet, Leadership in Government. \(Third District\)](#)

Board action: Approved as Recommended
UNANIMOUS VOTE
Approved by Resolution 18-0438

19. [Adopt a Gold Resolution Honoring Dr. Claudia Luke as the recipient of the North Bay Leadership Council's 2018 Leaders of the North Bay Award: Paint the Town Green, Environmental Stewardship. \(Third District\)](#)

Board action: Approved as Recommended
UNANIMOUS VOTE
Approved by Resolution 18-0439

20. [Adopt a Gold Resolution Honoring North Bay Fire Relief Fund Partnership as the recipient of the North Bay Leadership Council's 2018 Leaders of the North Bay Award: "United We Stand, Community Building." \(Third District\)](#)

Board action: Approved as Recommended
UNANIMOUS VOTE
Approved by Resolution 18-0440

9:08 A.M. Public Comment Opened

Public Speakers:
Duane DeWitt
Thomas Ells
Vicky Farrow
Ruth Wilson

9:14 A.M. Public Comment Closed

- III. [8:45 A.M. - PUBLIC COMMENT ON MATTERS NOT LISTED ON THE AGENDA BUT WITHIN THE SUBJECT MATTER JURISDICTION OF THE BOARD AND ON BOARD MEMBER REPORTS \(Comments are restricted to matters within the Board's jurisdiction. The Board will hear public comments at this time for up to thirty minutes. Each person is usually granted time to speak at the discretion of the Chair. Any additional public comments will be heard at the conclusion of the meeting. While members of the public are welcome to address the Board, under the Brown Act, Board members may not deliberate or take action on items not on the agenda.\)](#)

9:12 A.M. Public Comment Opened

Public Speakers:
Paula Swanson
Debra Bel
Duane DeWitt
Carolyn Lopez
Angie Tate
Fred Jones
Lynn Rossman
Stephanie Tower
Dee Schweitszer
Michelle Miller
Mary Morrison
Rosanne Snyder
Rachel Bell
James Savage
Maureen DeVoe
Robert McNash
Vanessa Vanderbeck
Richard Hannon
John Jenkel
Jenny O
David Best
Robert Rawson
Jane Eagle
Stuart Hyde
Judy Smith

Stephen Rahn

10:19 A.M. Public Comment Closed

IV. REGULAR CALENDAR

PERMIT AND RESOURCE MANAGEMENT

21. 9:00 A.M. - Rezoning to remove Z (Accessory Unit Exclusion) Combining District to allow for a potential future application for Accessory Dwelling Unit: Adopt an Ordinance rezoning the parcel to remove the Z (Accessory Unit Exclusion) Combining District located at 2642 Westside Rd, Healdsburg; APN 110-130-024; PRMD File No. ZCE17-0007; Supervisorial District 4. (Fourth District)

10:20 A.M.

Presenters:

Tennis Wick, Director, Permit and Resource Management Department

10:22 A.M. Public Hearing Opened

Public Speakers:

None

10:22 A.M. Public Hearing Closed

Board action: Approved as Recommended

UNANIMOUS VOTE

Approved by Ordinance 6243

HUMAN SERVICES

22. Human Services Department Appointment of Retiree Extra-Help:
- A) Pursuant to Government Code §7522.56, approve the appointment of Diane Kaljian as a former Assistant Director retiree extra-help employment, in order to provide additional assistance to the new Assistant Director within 180 days of her retirement, with an appointment date as early as October 17, 2018.
- B) Pursuant to Government Code §7522.56, approve the appointment of Carl Vanden Heuvel as a former Department Administrative Services Director retiree extra-help employment, in order to provide additional assistance to the new Department Administrative Services Director within 180 days of his retirement, with an appointment date as early as October 17, 2018.

This item was heard out of order.

10:19 A.M.

Presenters:

Karen Fies, Director, Human Services

10:20 A.M. Public Comment Opened

Public Speakers:

None

10:20 A.M. Public Comment Closed

Board action: Approved as Recommended

UNANIMOUS VOTE

COMMUNITY DEVELOPMENT COMMISSION
(Commissioners: Gorin, Rabbitt, Zane, Gore, Hopkins)

23. [Windsor Veterans Village – Tax Equity and Fiscal Responsibility Act of 1982 \(TEFRA\) Hearing to approve the issuance of multifamily housing revenue bonds: The Sonoma County Board of Supervisors is being asked to adopt a resolution which would approve the issuance of multifamily housing revenue bonds by the Golden State Finance Authority \(the “Authority”\) for the purpose of financing the construction and equipping of Windsor Veterans Village, a multifamily residential housing facility located in Sonoma County \(the “Project”\).](#)

10:22 A.M.

Presenters:

Benjamin Wickham, Affordable Housing Director, Community Development Commission
Mark Irving, Urban Housing Communities, Community Development Commission

10:28 A.M. Public Comment Opened

Public Speakers:

Thomas Ells

10:30 A.M. Public Comment Closed

Board action: Approved as Recommended

AYES: Gorin, Rabbitt, Zane, Gore

ABSTAIN: Hopkins

Approved by Resolution 18-0441

PERMIT AND RESOURCE MANAGEMENT

24. [9:15 A.M. - Cannabis Land Use Ordinance Amendments: Hold a public hearing and at the conclusion of the hearing adopt an Ordinance amending Chapter 26 of the Sonoma County Code to allow adult use cannabis businesses, enhance neighborhood compatibility, harmonize with State cannabis laws where appropriate, and make other minor amendments, adopt a Resolution finding the amendments are consistent with the General Plan and Area Plans, and determining exemption from the California Environmental Quality Act.](#)

10:32 A.M.

Presenters:

Amy Lyle, Planner, Permit and Resource Management Department
Tim Ricard, Cannabis Program Manager, Economic Development Board
Sita Kuteira, Deputy County Counsel

11:39 A.M Public Comment Opened

Public Speakers:

Laura Waldbaum

Rachel Ziert

Deborah Epstein

Joey Ereneta

Kathleen Hohnstein

Anna Ransome

Elizabeth Fritzingler

Robert Guthrie

Alexa Wall

Omar Figueroa

Cary Ford

Jo Bentz

Laura Mendelsohn

Jane Eagle

Joseph Perry

Matt Fitzinger
Michael Ingram
Joe Howard
Cecilia Dawson
Theresa Melia
Eric Snyder
Andrea Herold
James Lati
Bob Rawson
Mimi Bashaw
Brantley Richardson
Tawny Tesconi
Craig Harrison
David Drips
Jamie Ballachino
Donna Frank
Stephen Smith
Bess Hochstein
Joanne Cedar
China Dusk
Barry Wood

12:49 P.M. A.M. Public Comment Closed

Board Action:
Approved as recommended
UNANIMOUS VOTE
Approved by Ordinance 6245
Approved by Resolution 18-0442

BOARD OF SUPERVISORS

25. [Fee Waiver: Approve a fee waiver for room rental of the Guerneville Veterans Hall for free weekly meals provided by Redwood Empire Food Bank from October 18, 2018 to June 19, 2019 in the amount of \\$3280. \(Fifth District\)](#)

This item was taken out of order.

3:46 P.M.

Presenters:
Supervisor Hopkins, District 5

3:46 P.M. Public Comment Opened

Public Speakers:
None

3:46 P.M. Public Comment Closed

Board Action: Approved as Recommended
UNANIMOUS VOTE

26. [Sponsorship: Approve a Board Sponsorship of \\$500 for the 18th Annual Tribute to Veterans at the Sonoma County Veterans Memorial Building on November 8, 2018. \(Third District\)](#)

3:46 P.M.

Presenters:
Supervisor Zane, District 3

3:46 P.M. Public Comment Opened

Public Speakers:
None

3:46 P.M. Public Comment Closed

Board Action: Approved as Recommended
UNANIMOUS VOTE

27. [Board Sponsorship of the 26th Latino Health Forum:](#)

A) [Approve Board Sponsorship of the 26th Annual Latino Health Forum at Sonoma State University on November 1, 2018](#)

B) [Adopt a resolution authorizing a budgetary adjustment to the 2018-2019 Final Budget to transfer Appropriation from General Fund Contingencies in the amount of five thousand dollars \(\\$5,000\) to General Fund Non-Departmental Other Contributions for sponsorship of the 2018 Latino Health Forum. \(4/5th Vote Required\)](#)

3:46 P.M.

Presenters:
Michael Gossman, Deputy County Administrator, County Administrator's Office
Christel Querijero, Principal Administrative Analyst, County Administrator's Office

3:46 P.M. Public Comment Opened

Public Speakers:
None

3:46 P.M. Public Comment Closed

Board Action: Approved as Recommended
UNANIMOUS VOTE
Approved by Resolution 18-0443

V. [PUBLIC COMMENT ON CLOSED SESSION ITEMS](#)

This item was taken out of order.

2:24 P.M. Public Comment Opened

Public Speakers:
None

2:24 P.M. Public Comment Closed

VI. [CLOSED SESSION CALENDAR](#)

3:42 P.M. County Counsel Bruce Goldstein reported on Closed Session Item 28.

28. [The Board of Supervisors, the Board of Directors of the Water Agency, the Board Commissioners of the Community Development Commission, and the Board of Directors of The Agricultural Preservation and Open Space District will consider the following in closed session: Conference with Labor Negotiators: Christina Cramer/Carol Allen, County of Sonoma, and Rick Bolanos/Heather Coffman, Liebert Cassidy & Whitmore. Employee Organizations: All. Unrepresented employees: All, including retired employees. \(Government Code section 54957.6\).](#)

No reportable action. Direction was given to labor negotiators.

VII. [REGULAR AFTERNOON CALENDAR](#)

29. [RECONVENE FROM CLOSED SESSION](#)

Supervisors Present: Susan Gorin, David Rabbitt, Shirlee Zane, James Gore, Lynda Hopkins

Staff Present: Sheryl Bratton, County Administrator and Bruce Goldstein, County Counsel

30. [REPORT ON CLOSED SESSION](#)

3:42 P.M. County Counsel Bruce Goldstein reported on Closed Session Item 28.

VIII. [1:43 P.M. - PRESENTATIONS/GOLD RESOLUTIONS](#)

This item was taken out of order.

1:57 P.M. The Board went into recess.

BOARD OF SUPERVISORS

31. [Rural County Representatives of California Presentation: Receive presentation from Rural County Representatives of California \(RCRC\)](#)

This item was taken out of order.

2:25 P.M.

Presenters:

MaryAnn Warner, Senior Legislative Advocate, Rural County Representative of California
Tracy Rhine, Legislative Advocate, Rural County Representative of California

2:45 P.M. Public Comment Opened

Public Speakers:

None

2:45 P.M. Public Comment Closed

Board Action: Informational Only

PERMIT AND RESOURCE MANAGEMENT

32. [2:46 P.M. - Hearing on Draft Supplemental Environmental Impact Report for modifications to conditions of the Use Permit for the Roblar Road Quarry, File UPE16-0058: Informational item to hold a public comment hearing on the Draft Supplemental Environmental Impact Report \(Draft SEIR\). \(Second District\)](#)

Presenters:

Blake Hillegas, Supervisor, Permit and Resource Management Department
Jennifer Barrett, Deputy Director, Permit and Resource Management Department

3:06 P.M. Public Comment Opened

Public Speakers:

Margaret Hanley
Sue Buxton
Jason Merrick
Gary Reed
Joe Morgan

Donna Norton
Jane Nielson
Tom Yarish

3:26 P.M. Public Comment Closed

Board Action: Approved as Recommended
UNANIMOUS VOTE

32a. Amendments to Sonoma County Code Chapter 40 to Prevent Establishment of New Vacation Rentals Within the Sonoma Complex Fires Perimeter: Amendments to Sonoma County Code Chapter 40 to Prevent Establishment of New Vacation Rentals Within the Sonoma Complex Fires Perimeter:

A) Find that adoption of the proposed ordinance is exempt from CEQA pursuant to CEQA Guidelines section 15061(b)(3), and

B) Adopt the proposed ordinance.
THIS ITEM IS BEING ADDED TO THE OCTOBER 16, 2018 AGENDA AND CONTINUED TO OCTOBER 23, 2018 AGENDA.

IX. [BOARD MEMBER REPORTS ON ASSIGNED BOARDS, COUNCILS, COMMISSIONS OR OTHER ATTENDED MEETINGS](#)

Supervisor Hopkins attended a Santa Rosa Groundwater Sustainability Agency meeting.

Supervisor Gorin hosted a meeting of the Onsite Wastewater Treatment System (OWTS) in the Sonoma Valley.

Supervisor Zane toured the PG&E Wildfire Safety Unit with Supervisors Gore and Hopkins. She attended the Senior Seminar at the Marine Club discussing communities in disaster situations.

Supervisor Rabbitt attended a Court Appointed Special Advocates (CASA) meeting. He attended an Association of Bay Area Governments (ABAG) Administration Committee meeting and a Metropolitan Transportation Committee ABAG Governance Committee meeting

33. Permit and Resource Management Department: Review and possible action on the following:
Acts and Determinations of Planning Commission/Board of Zoning Adjustments
Acts and Determinations of Project Review and Advisory Committee
Acts and Determinations of Design Review Committee
Acts and Determinations of Landmarks Commission
Administrative Determinations of the Director of Permit and Resource Management
(All materials related to these actions and determinations can be reviewed at:
<http://www.sonoma-county.org/prmd/b-c/index.htm>)

There were no acts and determinations.

34. ADJOURNMENT

This Board adjourned the meeting in memory of Babetta Jean Wilson, Pam Hagemann and Rex Nance. The meeting adjourned to Tuesday, October 23, 2018 at 8:30 A.M.

Respectfully Submitted,

Kay Lowtrip
Chief Deputy Clerk of the Board

NOTE: The next Regular meeting will be held on October 23, 2018, at 8:30 a.m.

Upcoming Hearings (All dates are tentative until each agenda is finalized)
December 11, 2018 - Permit and Resource Management ? UPE14-0008 Ramey Winery

ACTION SUMMARY
BOARD OF SUPERVISORS
SONOMA COUNTY
575 ADMINISTRATION DRIVE, ROOM 102A
SANTA ROSA, CA 95403

TUESDAY

OCTOBER 23, 2018

8:30 A.M.

Susan Gorin	First District	Sheryl Bratton	County Administrator
David Rabbitt	Second District	Bruce Goldstein	County Counsel
Shirlee Zane	Third District		
James Gore	Fourth District		
Lynda Hopkins	Fifth District		

8:36 A.M. CALL TO ORDER

Supervisors Present: Susan Gorin, David Rabbitt, Shirlee Zane, James Gore, Lynda Hopkins

Staff Present: Sheryl Bratton, County Administrator and Bruce Goldstein, County Counsel

PLEDGE OF ALLEGIANCE

I. [APPROVAL OF THE AGENDA \(Items may be added or withdrawn from the agenda consistent with State law\)](#)

The Chair announced that there was an agenda addendum:

THE FOLLOWING ITEM WAS ADDED TO THE CONSENT CALENDAR:

HUMAN RESOURCES
AND
**AGRICULTURAL PRESERVATION AND OPEN SPACE DISTRICT/
SONOMA COUNTY WATER AGENCY**
(Directors: Gorin, Rabbitt, Zane, Gore, Hopkins)

34a. Side Letter to the Memorandum of Understanding between the County of Sonoma and Service Employees' International Union, Local 1021;

Adopt a Concurrent Resolution approving a Side-Letter Agreement between the County of Sonoma and the Service Employees' International Union Local 1021.

THE FOLLOWING ITEM WAS REMOVED FROM THE CONSENT CALENDAR:

COUNTY ADMINISTRATOR/COUNTY COUNSEL

12. Amendment to Intergovernmental Mitigation Agreement with Federated Indians of Graton Rancheria:
Authorize the Chair to execute Amendment No. 1 to the 2012 Intergovernmental Mitigation Agreement with the Federated Indians of Graton Rancheria including the enforcement of Mitigation Measures identified in the Final Tribal Environmental Impact Report and dispute resolutions. (Second District)

Board action: Approved as Recommended
UNANIMOUS VOTE

II. [CONSENT CALENDAR](#)

GENERAL SERVICES
AND
**AGRICULTURAL PRESERVE AND OPEN SPACE DISTRICT/
SONOMA COUNTY WATER AGENCY**
(Directors: Gorin, Rabbitt, Zane, Gore, Hopkins)

1. [Adopt an Ordinance Vacating Approval of the Chanate Campus Development and Disposition Agreement By Rescinding Ordinance No. 6205: Adopt Ordinance No. 6246 Rescinding Ordinance No. 6205 and vacating the approval of the Development and Disposition Agreement to sell the Chanate Campus to Chanate Community Development Partners, LLC. \(Second Reading- Ready for Adoption\)](#)

Board action: Approved as Recommended
 UNANIMOUS VOTE
 Approved by Ordinance 6246

**SONOMA COUNTY WATER AGENCY/
 RUSSIAN RIVER COUNTY SANITATION DISTRICT**

(Directors: Gorin, Rabbitt, Zane, Gore, Hopkins)

2. [Maintenance of Electrical Distribution Lines: In an effort to ensure safety and reliability of the distribution lines and to reduce the risk of fire, authorize Sonoma County Water Agency’s General Manager acting on behalf of Russian River County Sanitation District to execute an agreement for as-needed inspection, maintenance, and emergency repair services for 12kV and 5kV electrical distribution lines with INTREN, LLC, through October 31, 2021, in the not-to-exceed amount of \\$240,000. \(Fourth and Fifth Districts\)](#)

Board action: Approved as Recommended
 UNANIMOUS VOTE

HUMAN RESOURCES

AND

SONOMA COUNTY WATER AGENCY

(Directors: Gorin, Rabbitt, Zane, Gore, Hopkins)

3. [Memorandum of Understanding extension between the County of Sonoma and the Western Council of Engineers \(WCE\): Adopt a Concurrent Resolution approving an extension to the Memorandum of Understanding \(MOU\) between the County of Sonoma and WCE for the period of July 1, 2018 through July 1, 2019.](#)

Board action: Approved as Recommended
 UNANIMOUS VOTE
 Approved by Resolution 18-0444

COUNTY ADMINISTRATOR

AND

SONOMA VALLEY SANITATION DISTRICT

(Directors: Gorin, Gore, Agrimonti)

4. [Fiscal Year 2018-19 First Quarter Budget Adjustments:](#)
 - A) [Adopt a Concurrent Resolution adjusting the FY 2018-19 Budget Appropriations by \\$69,967,397. \(4/5th vote required\)](#)
 - B) [Adopt a Resolution of the Sonoma Valley County Sanitation District adjusting the FY 2018-19 Budget by \\$1,031,321 \(2/3rd vote required\) \(4/5th Vote required\)\(\(2/3rd Vote required SVSD\)](#)

Board action: Approved as Recommended
 UNANIMOUS VOTE
 Approved by Resolution 18-0445

Sonoma Valley County Sanitation District
 Board Action: Approved as Recommended
 AYES: Gorin, Gore
 ABSENT: Agrimonti
 Approved by Resolution 18-0446

SONOMA COUNTY WATER AGENCY

(Directors: Gorin, Rabbitt, Zane, Gore, Hopkins)

5. [Engineering Review of Development Plans: In an ongoing effort to mitigate potential damage to Sonoma County Water Agency infrastructure, public health and safety, and the environment from new construction, authorize Sonoma County Water Agency's General Manager to execute an agreement with Coastland Civil Engineering, Inc., for engineering review of development plans through October 31, 2021, in the not-to-exceed amount of \\$600,000.](#)

Board action: Approved as Recommended
UNANIMOUS VOTE

6. [Quagga and Zebra Mussel Inspection, Demonstration, and Training:](#)
 - A) [Authorize Sonoma County Water Agency's General Manager to execute the First Amended Agreement for Quagga and Zebra Mussel Inspection and Training with Dogs With Jobs, LLC to continue providing quagga and zebra mussel inspection, demonstration, training, and related services increasing the amount by \\$125,000 for a new not-to-exceed agreement total of \\$355,000 with no change to end date of December 31, 2019.](#)
 - B) [Adopt a resolution authorizing adjustments to the Sonoma County Water Agency's Fiscal Year 2018/2019 adopted budget for the Russian River Projects in the amount of \\$125,000 for the quagga and zebra mussel inspection and training. \(Fourth District\)\(4/5th Vote Required\)](#)

Board action: Approved as Recommended
UNANIMOUS VOTE
Approved by Resolution 18-0447

COMMUNITY DEVELOPMENT COMMISSION
(Commissioners: Gorin, Rabbitt, Zane, Gore, Hopkins)

7. [Housing Authority Program and Service Delivery Enhancements](#)
 - A) [Approve amendment to the Housing Authority Administrative Plan](#)
 - B) [Authorize the Executive Director of the Sonoma County Community Development Commission \(SCCDC\) to execute a Professional Services Agreement with NMA Inspection Services, LLC to perform inspections of rental housing units assisted under the Commission's programs for a term of November 1, 2018, through October 31, 2020, with three one-year renewal options.Plan.](#)

Board action: Approved as Recommended
UNANIMOUS VOTE

AUDITOR- CONTROLLER-TREASURER-TAX COLLECTOR

8. [Resolution Designating of Applicant's Agent for Cal OES: Adopt resolution designating the County Administrator, the Auditor-Controller-Treasurer-Tax Collector and the ACTTC Client Accounting Manager as authorized agents of the County of Sonoma for Cal OES \(State of California Governor's Office of Emergency Services\) public assistance grants.](#)

Board action: Approved as Recommended
UNANIMOUS VOTE
Approved by Resolution 18-0448

BOARD OF SUPERVISORS

9. [Disbursement of Neighborhood Improvement Funds from the Cal American Franchise Tax Fee: Adopt a resolution authorizing budgetary adjustments to the Fiscal Year 2018-19 Final Budget for the Transportation and Public Works department. The requested budget adjustment of \\$18,400 will provide appropriations for the Neighborhood Improvement Program in the Mark West, Larkfield, Wikiup, and Fulton area. The funding source for the request is the Cal-Am Franchise Fees fund \(10056\). \(Fourth District\) \(4/5th Vote Required\)](#)

Board action: Approved as Recommended
UNANIMOUS VOTE
Approved by Resolution 18-0449

10. [California State Association of Counties Board of Directors Assignment: Nominate Supervisor James Gore as the Board's primary appointment to the California State Association of Counties Board of Directors and Supervisor Susan Gorin as the alternate.](#)

Board action: Approved as Recommended
UNANIMOUS VOTE

11. [Statewide Ballot Measures: Consider taking a formal position on statewide ballot measures: Proposition 1, Proposition 2, Proposition 5, and Proposition 6.](#)

Board action: Approved as Recommended
UNANIMOUS VOTE
Approved by Resolutions 18-0463, 18-0464, 18-0465 and 18-0466

COUNTY ADMINISTRATOR/COUNTY COUNSEL

12. [Amendment to Intergovernmental Mitigation Agreement with Federated Indians of Graton Rancheria: Authorize the Chair to execute Amendment No. 1 to the 2012 Intergovernmental Mitigation Agreement with the Federated Indians of Graton Rancheria including the enforcement of Mitigation Measures identified in the Final Tribal Environmental Impact Report and dispute resolutions. \(Second District\)](#)

This item was removed from the agenda.

COUNTY ADMINISTRATOR/ FIRE AND EMERGENCY SERVICES

13. [Extend Proclamation of Local Emergency Due to Sonoma Complex Fire: Adopt a Resolution Extending the Proclamation of Local Emergency Issued on October 9, 2017, for another 30 Days Due to Damage Arising from the Complex Fire. \(4/5th Vote Required\)](#)

Board action: Approved as Recommended
UNANIMOUS VOTE
Approved by Resolution 18-0450

14. [Recovery Update: Receive update on the status of recovery operations, planning, seeking of funding opportunities, community engagement and status of recovery framework.](#)

Board action: Approved as Recommended
UNANIMOUS VOTE

DISTRICT ATTORNEY'S OFFICE

15. [District Attorney 2018-19 Automobile Insurance Fraud Program: Adopt a resolution authorizing the District Attorney to execute the grant agreement with the California Department of Insurance to participate in the Automobile Insurance Fraud Program and accept \\$55,479 in grant funding for the term July 1, 2018 through June 30, 2019. The objective of this grant is to protect public safety resulting from criminal enterprises staging traffic collisions and vendors providing faulty vehicle repairs and placing dangerous and unsafe vehicles back on the road.](#)

Board action: Approved as Recommended
UNANIMOUS VOTE

16. [District Attorney 2018-19 Workers' Compensation Insurance Fraud Investigation Program: Adopt a resolution authorizing the District Attorney to execute the grant agreement with the California Department of Insurance to participate in the Workers' Compensation Insurance Fraud Investigation Program and accept \\$98,457 in grant funding for the term July 1, 2018 through June 30, 2019. The objective of this grant is to uncover fraud within the community that harms workers and businesses, and prosecute those who perpetrate such crimes.](#)

Board action: Approved as Recommended
UNANIMOUS VOTE

17. [District Attorney's Homeless Victims of Crime Program: Execute a contract with the California Governor's Office of Emergency Services for the Outreach and Services to Homeless Victims of Crime Grant Program.](#)
- A) [Adopt a resolution authorizing the District Attorney to execute a contract with the California Governor's Office of Emergency Services to accept additional funding and extend the term of the original grant for direct services revenue in the amount of \\$380,979 through December 31, 2019.](#)
- B) [Adopt a resolution extending the 1.0 FTE Administrative Aide-Time Limited position through December 31, 2019 to continue to support this program. The objective of the Outreach and Services to Homeless Victims of Crime program is to provide advocacy, case management and prosecution to the most vulnerable in Sonoma County, disabled homeless victims of crime. \(4/5th Vote Required\)](#)

Board action: Approved as Recommended
UNANIMOUS VOTE
Approved by Resolution 18-0453 and 18-0454

FIRE AND EMERGENCY SERVICES

18. [Fire Services Project Update:](#)
- A) [Accept an update on the Fire Services Project.](#)
- B) [Authorize the Interim Director of Fire and Emergency Services to Enter into an Agreement with the fire agencies listed in Attachment 1 to maintain existing service levels.](#)

Board action: Approved as Recommended
UNANIMOUS VOTE

19. [Vegetation Management Inspection Agreements with Fire Protection Districts Enforcing County Ordinance No. 6148, Abatement of Hazardous Vegetation and Combustible Materials: Authorize the Director of Fire and Emergency Services to enter into agreements with local Fire Protection Districts to implement a Vegetation Management Inspection Program in partnership with the Sonoma County Fire Prevention Division to reduce vegetation fuel loads and enhance public safety. The program will be active for a term of one year, as funding permits, not-to-exceed \\$500,000 in Fiscal Year 2018-19; any remaining funds to carry over to Fiscal Year 2019-20.](#)

Board action: Approved as Recommended
UNANIMOUS VOTE

GENERAL SERVICES/HEALTH SERVICES

20. [Lease Amendment for Department of Health Services at 490 Mendocino Avenue, Santa Rosa: Authorize the Clerk to publish a notice, declaring the Board's intention to execute a Lease Amendment with 490 MENDOCINO T.I.C \(Landlord\), for office space at 490 Mendocino Avenue, Suites 101, 102, 103, Santa Rosa; to extend the lease for a six month period to expire May 31, 2019, at a rental rate of \\$21,760.90 per month \(\\$2.27per sq. ft.\), to allow the Department of Health Services' Health Policy, Planning and Evaluation Unit \(HPPE\) to continue uninterrupted operations on the Premises while it waits for tenant improvements to be completed at its future location at 1450 Neotomas Avenue, Santa Rosa.](#)

Board action: Approved as Recommended
UNANIMOUS VOTE

HUMAN RESOURCES

21. [Memorandum of Understanding extension between the County of Sonoma and the Engineers and Scientists of California, Local 20 \(ESC\). Adopt a Resolution approving an extension to the Memorandum of Understanding \(MOU\) between the County of Sonoma and Engineers and Scientists of California, Local 20 \(ESC\) for the period of October 23, 2018 through March 26, 2019.](#)

Board action: Approved as Recommended
UNANIMOUS VOTE
Approved by Resolution 18-0455

PERMIT AND RESOURCE MANAGEMENT

22. [Land Conservation Act Contract Replacement; Zane Holdings LLC: Adopt a Resolution to mutually rescind and replace a Non-prime \(Type II\) Land Conservation Act contract with an Open Space \(Type II\) Land Conservation Act contract for an 80 acre property located at 9685 Dry Creek Rd., Healdsburg; APN 139-060-030; Permit Sonoma File No. AGP17-0010; Supervisorial District 4. \(Fourth District\)](#)

Board action: Approved as Recommended
UNANIMOUS VOTE
Approved by Resolution 18-0456

23. [Land Conservation Act Contract Replacement; Zane Holdings LLC: Adopt a Resolution to mutually rescind and replace a Non-prime \(Type II\) Land Conservation Act contract with an Open Space \(Type II\) Land Conservation Act contract for 107.87 acre property located at 9695 Dry Creek Rd., Healdsburg; APN 139-060-032; Permit Sonoma File No. AGP17-0016; Supervisorial District 4. \(Fourth District\)](#)

Board action: Approved as Recommended
UNANIMOUS VOTE
Approved by Resolution 18-0457

PROBATION

24. [The Keeping Kids in School Initiative: Authorize the Chief Probation Officer to enter into Memorandum of Understanding agreements with Healdsburg Unified School District and Windsor Unified School District to receive Keeping Kids in School program services through June 30, 2020.](#)

Board action: Approved as Recommended
UNANIMOUS VOTE

25. [Noble Software Group, LLC, Software License and Services Agreement: Authorize the Chief Probation Officer to execute an agreement with Noble Software Group, LLC, to provide validated assessment tools, a web-based, fully-integrated software application, software maintenance and training for the period of October 23, 2018 to October 22, 2021, with two one-year renewal options, in a total amount not to exceed \\$346,181.](#)

Board action: Approved as Recommended
UNANIMOUS VOTE

PUBLIC DEFENDER

26. [Approval of Capital Case Contract and Related Budgetary Adjustments:](#)
 - A) [Authorize the Law Offices of the Public Defender to enter into a contract with The Law Office of Eric Multhaupt to provide Keenan Counsel Capital Case Mitigation services for a not to exceed amount of \\$250,000 necessary to cover the capital case expenses per Penal Code 987.9 through June 30, 2020.](#)
 - B) [Authorize the Law Offices of the Public Defender to enter into a contract with L. Page Investigations & Mitigation, LLC to provide Mitigation Investigation services for a not to exceed amount of \\$150,000 necessary to cover the capital case expenses per Penal Code 987.9 through June 30, 2020.](#)

- C) [Authorize the use of Contingencies and Adopt a Budget Resolution increasing the FY18-19 adopted budget in the amount of \\$940,000 to cover \\$400,000 in contract costs and \\$540,000 for the costs of an Extra-Help Attorney, an Extra Help Investigator and costs associated with discovery and other related case expenses. \(4/5th Vote Required\)](#)

Board action: Approved as Recommended
UNANIMOUS VOTE
Approved by Resolution 18-0458

REGIONAL PARKS

27. [Regional Parks Day Use Fee Waiver to Honor Veterans: Approve waiver of day use fees throughout Sonoma County Regional Parks system for eligible military personnel and dependents for Veterans Day weekend, starting on Friday, November 9, 2018 through Monday, November 12, 2018.](#)

Board action: Approved as Recommended
UNANIMOUS VOTE

SHERIFF'S OFFICE

28. [Involuntary Medication, California Penal Code Section 2603: Designate the Sonoma County Sheriff's Office as the department who may administer involuntary medication to inmates in the jail on a non-emergency basis pursuant to California Penal Code Section 2603. The Sheriff's Office is requesting this designation to improve care for mentally ill inmates and to help mitigate distressing situations that may cause danger to inmates and correctional staff. If approved, the Sheriff's Office will be able to apply to the Superior Court for an order allowing the administration of involuntary medication to inmates, as specified in Penal Code Section 2603.](#)

Board action: Approved as Recommended
UNANIMOUS VOTE

TRANSPORTATION AND PUBLIC WORKS

29. [2018 Hazard Tree Removal Project – Road Right-of-Way Trees, Project # M11719: Approve and authorize the Chair to execute an agreement for construction inspection services with Coastland Civil Engineering Inc. for the 2018 Hazard Tree Removal Project – Road Right-of-Way Trees, Project # M11719, for an amount not to exceed \\$205,025 including a \\$50,000 contingency. This agreement is for a term ending June 30, 2019. \(First and Fourth Districts\)](#)

Board action: Approved as Recommended
UNANIMOUS VOTE

APPOINTMENTS/REAPPOINTMENTS

30. [Approve the Appointment of Kevin Howe to the Sonoma County Fair Board \(First District\), effective October 23, 2018 and expiring at the pleasure of the Board. \(First District\)](#)

Board action: Approved as Recommended
UNANIMOUS VOTE

31. [Adopt a Resolution approving the appointment of members to the Sonoma County Tobacco Securitization Corporation. \(Auditor-Controller-Treasurer-Tax Collector\)](#)

Board action: Approved as Recommended
UNANIMOUS VOTE
Approved by Resolution 18-0459

32. [Appointments and Reappointments to the Sonoma County Workforce Investment Board \(WIB\):](#)

- A) [Approve the appointment of Nancy Emanuele and David Tam to the Sonoma County Workforce Investment Board for a one-year term beginning October 23, 2018, and ending October 23, 2019.](#)

- B) [Approve the re-appointment of Ananda Sweet and David Wayte to the Sonoma County Workforce Investment Board for a two-year term beginning October 23, 2018, and ending October 23, 2020. \(Human Services\)](#)

Board action: Approved as Recommended
UNANIMOUS VOTE

33. [Upstream Investments Portfolio Review Committee Appointments & Reappointments](#)

- A) [Approve the appointments of new Upstream Investments Portfolio Review Committee members Kathryn Pack, Mary Watts, Ariana Diaz de Leon, Nicollette Weinzveg and Cynthia King to serve an initial two-year term beginning on October 23, 2018, and ending on October 22, 2020.](#)
- B) [Approve the re-appointments of current Upstream Investments Portfolio Review Committee members Alison Lobb, Liz Parra, Renée Alger, Carlos Ayala and B.J. Bischoff for an additional one-year term beginning on October 23, 2018, and ending on October 22, 2019. \(Human Services\)](#)

Board action: Approved as Recommended
UNANIMOUS VOTE

PRESENTATIONS/GOLD RESOLUTIONS

PRESENTATION ON A DIFFERENT DATE

- 34. [Adopt a resolution honoring November 11, 2018 as “Veterans Day” in Sonoma County. \(Human Services\)](#)

Board action: Approved as Recommended
UNANIMOUS VOTE
Approved by Resolution 18-0460

HUMAN RESOURCES
AND
**AGRICULTURAL PRESERVATION AND OPEN SPACE DISTRICT/
SONOMA COUNTY WATER AGENCY**
(Directors: Gorin, Rabbitt, Zane, Gore, Hopkins)
AND
COMMUNITY DEVELOPMENT COMMISSION
(Commissioners: Gorin, Rabbitt, Zane, Gore, Hopkins)

- 34a. Side Letter to the Memorandum of Understanding between the County of Sonoma and Service Employees? International Union, Local 1021:
Adopt a Concurrent Resolution approving a Side-Letter Agreement between the County of Sonoma and the Service Employees? International Union Local 1021.

Board Action: Approved as Recommended
UNANIMOUS VOTE
Approved by Resolution 18-0461

9:04 A.M. Public Comment Opened

Public Speakers:
Duane De Witt
Marina Abbot
Mike Nicholls
John Jenkel

9:12 A.M. Public Comment Closed

III. [9:15 A.M. - PUBLIC COMMENT ON MATTERS NOT LISTED ON THE AGENDA BUT WITHIN THE SUBJECT MATTER JURISDICTION OF THE BOARD AND ON BOARD MEMBER REPORTS](#)

(Comments are restricted to matters within the Board’s jurisdiction. The Board will hear public comments at this time for up to thirty minutes. Each person is usually granted time to speak at the discretion of the Chair. Any additional public comments will be heard at the conclusion of the meeting. While members of the public are welcome to address the Board, under the Brown Act, Board members may not deliberate or take action on items not on the agenda.)

9:15 A.M. Public Comment Opened

Thomas Ells
Will Abrams
Duane De Witt
Scott Wagner
Michelle Miler
Mary Morrison
Roseanne Snyder
Maureen De Voe
Vanessa
James Savage
Rachel Bell
Richard Hannon
John Jenkel

9:44 A.M. Public Comment Closed

IV. REGULAR CALENDAR

BOARD OF SUPERVISORS

35. Informational Presentation: Committee to House the Bay Area (CASA): Receive informational presentation by the Association of Bay Area Governments (ABAG) and Metropolitan Transportation Commission (MTC) regarding the CASA Compact. (Informational Only)

9:44 A.M.

Presenters:

Rebecca Long, Manager, Government Relations, Metropolitan Transportation Commission

10:48 A.M. Public Comment Opened

Public Speakers:

Thomas Ells
Teri Shore
Brian Ling
Shelley Clark
Courtney DeAngelis

10:38 A.M. Public Comment Closed

Board action: Informational Only

PERMIT AND RESOURCE MANAGEMENT

36. 11:03 A.M. - Zoning Code Changes to Expand Housing Opportunities: Hold a public hearing, adopt the Negative Declaration, and adopt the ordinance making changes to Chapter 26 of the Sonoma County Code (Zoning) to expand opportunities for housing.

11:03 A.M.

Presenters:

Tennis Wick, Director, Permit and Resource Management Department
Jennifer Barrett, Deputy Director, Permit and Resource Management Department

Jane Riley, Planner, Permit and Resource Management Department
Christa Shaw, Deputy County Counsel

12:00 P.M. Public Hearing Opened

Public Speakers:
Teri Shore
Walter Kiezer
Bruce Aspinall
Thomas Ells

12:11 P.M. Public Hearing Closed

Deputy Director Jennifer Barrett and County Counsel Christa Shaw read changes to exhibits D, I and J into the record, based upon direction from the Board. The changes will be reflected in the final approved items. For the cottage housing developments proposal (Exhibit I), the Board modified the draft ordinance as applied to the burn area, approving the recommended minimum separation criteria for cottage housing developments in Glen Ellen and directing that cottage housing developments not be allowed in Larkfield.

Board action: Approved as Amended
UNANIMOUS VOTE
Approved by Ordinance 6247

V. [PUBLIC COMMENT ON CLOSED SESSION ITEMS](#)

2:00 P.M. Public Comment opened

Public Speakers:
None

2:00 P.M. Public Comment closed

VI. [CLOSED SESSION CALENDAR](#)

2:01 P.M. County Counsel reported on Closed Session Items 37 through 45.

37. [The Board of Supervisors will consider the following in closed session: Conference with Legal Counsel – Existing Litigation - County of Sonoma v. Philip Thomas Wheeler, SCV 234234 - 9214 Rio Dell Ct., Forestville – District 5 \(Government Code Section 54956.9\(d\)\(1\).\)](#)

No reportable action. Direction was given to counsel and staff.

38. [The Board of Supervisors will consider the following in closed session: Conference with Legal Counsel – Existing Litigation - County of Sonoma v. Fields of the Wood Church, SCV 257212 - 1080, 1122, 1150 and 1196 Liberty Road, Petaluma - District 2 \(Government Code Section 54956.9\(d\)\(1\).\)](#)

No reportable action. Direction was given to counsel and staff.

39. [The Board of Supervisors will consider the following in closed session: Conference with Legal Counsel – Existing Litigation - County of Sonoma v. James Quail, SCV 256085 - 3574 Brooks Ave., 423 & 427 Ward Ave. Santa Rosa, District 3 \(Government Code Section 54956.9\(d\)\(1\).\)](#)

No reportable action. Direction was given to counsel and staff.

40. [The Board of Supervisors will consider the following in closed session: Conference with Legal Counsel ? Existing Litigation - County of Sonoma v. William Tinker, 18446 & 18450 First Ave., Boyes Hot Springs ? District 1 \(Government Code Section 54956.9\(d\)\(1\).\)](#)

No reportable action. Direction was given to counsel and staff.

41. [The Board of Supervisors will consider the following in closed session: Conference with Legal Counsel – Existing Litigation – County of Sonoma v. Celeste Baker Mendiboure Estate, et al., Paul Joseph Mendiboure, Pierre Jean Mendiboure, Rene Adrian Mendiboure, and Does 1 to 20, inclusive, SCV 254612 - 2706 Victoria Drive, Santa Rosa, District 5 \(Government Code Section 54956.9\(d\)\(1\).\)](#)

No reportable action. Direction was given to counsel and staff.

42. [The Board of Supervisors will consider the following in closed session: Conference with Legal Counsel – Existing Litigation – County of Sonoma v. George Goulart., Sonoma County Superior Court Case No. SCV 245028 – 4135 Bodega Ave., Petaluma – District 2 \(Government Code Section 54956.9\(d\)\(1\).\)](#)

No reportable action. Direction was given to counsel and staff.

43. [The Board of Supervisors will consider the following in closed session: Conference with Legal Counsel ? Existing Litigation ? County of Sonoma v. Stephen Palka, Case No. SCV 261970 - 17632 Neeley Road, Guerneville ? District 5 \(Government Code Section 54956.9\(d\)\(1\).\)](#)

No reportable action. Direction was given to counsel and staff.

44. [The Board of Supervisors will consider the following in closed session: Conference with Legal Counsel “ Anticipated Litigation. Significant exposure to litigation and potential initiation of litigation pursuant to Government Code Sections 54956.9\(d\)\(2\) & \(4\). 1 case. Re: Code Enforcement matter re: property at 3062 Adobe Rd., Petaluma; APN 017-070-023; District 2.](#)

The Board approved a Stipulated Administrative Abatement Order in the code enforcement case for the property located at 3062 Adobe Rd., Petaluma, requiring all growing of cannabis to cease by November 1, all remaining cannabis cultivation activities to cease by November 15, a permanent prohibition on commercial cannabis cultivation on the property, and a lump sum payment of \$415,000.

UNANIMOUS VOTE

45. [The Board of Supervisors, the Board of Directors of the Water Agency, the Board Commissioners of the Community Development Commission, and the Board of Directors of The Agricultural Preservation and Open Space District will consider the following in closed session: Conference with Labor Negotiators: Christina Cramer/Carol Allen, County of Sonoma, and Rick Bolanos/Heather Coffman, Liebert Cassidy & Whitmore. Employee Organizations: All. Unrepresented employees: All, including retired employees. \(Government Code section 54957.6\).](#)

No reportable action. Direction was given to counsel and staff.

VII. [REGULAR AFTERNOON CALENDAR](#)

46. [RECONVENE FROM CLOSED SESSION](#)

Supervisors Present: Susan Gorin, David Rabbitt, Shirlee Zane, James Gore, Lynda Hopkins

Staff Present: Sheryl Bratton, County Administrator and Bruce Goldstein, County Counsel

47. [REPORT ON CLOSED SESSION](#)

2:01 P.M. County Counsel reported on Closed Session Items 37 through 45.

[PERMIT AND RESOURCE MANAGEMENT](#)

48. [2:03 P.M. - Appeal of a Use Permit and Design Review for a winery and public tasting room with agricultural promotional and industry wide events \(Hale Winery\). Andrew Dieden, Appellant. PRMD File No. PLP05-0062: Hold a public hearing and at the conclusion of the hearing, adopt a resolution denying the appeal and upholding the Board of Zoning Adjustments’ approval of a previously approved Use Permit and Design Review for Hale Winery with a 25,000 case maximum annual production capacity, a public tasting room, a storage barn, 12 agricultural](#)

[promotional events, and eight industry-wide total event days on 40 acres, located at 4304 Dry Creek Road, Healdsburg. \(Fourth District\)](#)

2:05 P.M. Assistant County Counsel Robert Pittman replaced County Counsel Bruce Goldstein.

Presenters:

Traci Tesconi, Planning Manager, Permit and Resource Management Department
Jennifer Barrett, Deputy Director Planning, Permit and Resource Management Department
Tennis Wick, Director, Permit and Resource Management Department

2:24 P.M. Public Comment Opened

Public Speakers:

Ken Wilson
Tom Billeter
Darlene Whitlock
Jon Pelleriti
Antoine Fauero
Catherine Ambisi
James Ferguson
Lincoln Chris
Peter Van Gelder
William Green
Sawyer Wilson
Michael Thin

2:58 P.M. Assistant County Administrator Christina Rivera replaced County Administrator Sheryl Bratton.

Robert Pousman
Laurie Pousman
Arlene Maximo
Margaret Mesris
Charles Day
Anne Vercelli
Kimberly Corcran
Andrew Dieden
Arielle Harris
George Unti
Mick Unti
Katie McClain Mengai
Marc Bowbersbich
Brytann Busick
Victoria Wilson
Ann Petersen
Nancy Benill
Terry Smith
Virgil Beasly
Monte Hanson
Sydni Nicholas
Diane Nolan
Truman Reynolds
Mike Delmanowski
William Fumich

4:28 P.M. Public Comment Closed

Board action:

The Board amended the following conditions:

Condition 54 add: The driveway improvements shall be designed to ensure continued access to the shared vineyard road with

the Unti property to the south for vehicles, including agricultural vehicles.

Condition 69 add: After hour agricultural promotional events shall be no more than 50 people. Agricultural promotional events shall be limited to no more than two (2) per month. At least 50% of the grapes shall be from Sonoma County, except in the event of disease, drought, fire or similar circumstance. Thehe detached barrel storage building is for dry storage only

Condition 75 add: Landscaping plans shall include a berm and vegetation screening of the parking area and shall also screen the use from neighboring properties to the extent feasible.

Condition 92 add: The applicant shall make a request to the Dept. Of Transportation and Public Works to consider designating all of Dry Creek Road as a no parking zone and if approved shall apply for an encroachment permit and install no parking signs along their street frontage.

Condition 97 change to a one-year review of event activities, including the adequacy of parking.

Approved as Amended

AYES: Rabbitt, Zane, Gore, Hopkins

NOES: Gorin

Approved by Resolution 18-0462

49. [5:09 P.M. - Amendments to Sonoma County Code Chapter 40 to Temporarily Prevent Establishment of New Vacation Rentals Within the Sonoma Complex Fire Perimeter:](#)
 - A) [Find that adoption of the proposed ordinance is exempt from CEQA pursuant to CEQA Guidelines section 15061\(b\)\(3\), and;](#)
 - B) [Adopt the proposed ordinance. \(First and Fourth Districts\)](#)

5:09 P.M.

Presenters:

Christa Shaw, Deputy County Counsel

Jane Riley, Division Manager, Permit and Resource Management Department

Jennifer Barrett, Deputy Director Planning, Permit and Resource Management Department

Tennis Wick, Director, Permit and Resource Management Department

5:16 P.M. County Administrator Sheryl Bratton replaced Assistant County Administrator Christina Rivera.

5:18 P.M. Public Comment Opened

Public Speakers:

Velma Simms

5:21 P.M. Public Comment Closed

Board action: Approved as Recommended

UNANIMOUS VOTE

Approved by Ordinance 6248

VIII. [BOARD MEMBER REPORTS ON ASSIGNED BOARDS, COUNCILS, COMMISSIONS OR OTHER ATTENDED MEETINGS](#)

Supervisor Hopkins attended a First 5 Commission meeting on October 22, 2018. She also attended an North Coast Regional Partnership (NCRP) meeting with Supervisor Gore.

50. Permit and Resource Management Department: Review and possible action on the following: Acts and Determinations of Planning Commission/Board of Zoning Adjustments
Acts and Determinations of Project Review and Advisory Committee
Acts and Determinations of Design Review Committee

Acts and Determinations of Landmarks Commission
Administrative Determinations of the Director of Permit and Resource Management
(All materials related to these actions and determinations can be reviewed at:
<http://www.sonoma-county.org/prmd/b-c/index.htm>)

5:26 P.M.

Board Action:

The Board accepted the Acts and Determinations.

UNANIMOUS VOTE

51. ADJOURNMENT

5:58 P.M. The meeting was adjourned to a Special Closed Session on October 30, 2018 at 10:00 A.M.

Respectfully submitted,

Kay Lowtrip

Chief Deputy Clerk of the Board

NOTE: The next meeting will be a Special Closed Session held on October 30, 2018 at 8:30 a.m.

The next Regular meeting will be held on November 13, 2018, at 8:30 a.m.

Upcoming Hearings (All dates are tentative until each agenda is finalized)

November 13, 2018 ? PRMD - PLP16-0011 Farm Stays, Hosted Rentals & Marketing Accommodations in LIA, LEA and DA. October 23, 2018 2

**ACTION SUMMARY
COUNTY OF SONOMA
BOARD OF SUPERVISORS
TUESDAY, OCTOBER 30, 2018**

Supervisors Susan Gorin, David Rabbitt, Shirlee Zane, James Gore, Lynda Hopkins
Sheryl Bratton, County Administrator
Bruce Goldstein, County Counsel

10:06 A.M. CALL TO ORDER

Supervisors Present: David Rabbitt, Shirlee Zane, James Gore, Lynda Hopkins

Supervisors Absent: Susan Gorin

Staff Present: Sheryl Bratton, County Administrator and Bruce Goldstein, County Counsel

PLEDGE OF ALLEGIANCE

- I. [APPROVAL OF THE AGENDA \(Items may be added or withdrawn from the agenda consistent with State law\)](#)

Board Action:

Approved as Recommended

AYES: Rabbitt, Zane, Gore, Hopkins

ABSENT: Gorin

- II. [BOARD MEMBER REPORTS ON ASSIGNED BOARDS, COUNCILS, COMMISSIONS OR OTHER ATTENDED MEETINGS](#)

Supervisor Zane attended Helen Rudee's funeral, the first female Supervisor of Sonoma County. She attended an Immigration Reform Committee for the National Association of Counties (NaCo). She participated in the Military and Veterans Services Committee discussing veteran's housing and mental health.

Supervisor Hopkins attended a Municipal Advisory Council (MAC) meeting in Sea Ranch discussing formation. She attended a Town Hall discussing early childhood education.

Supervisor Gore attended a meeting with Housing and Urban Development (HUD) in Washington D.C. with Supervisor Gorin discussing funding.

- III. [10:14 A.M. - PUBLIC COMMENT ON MATTERS NOT LISTED ON THE AGENDA BUT WITHIN THE SUBJECT MATTER JURISDICTION OF THE BOARD AND ON BOARD MEMBER REPORTS \(Comments are restricted to matters within the Board's jurisdiction. The Board will hear public comments at this time for up to thirty minutes. Each person is usually granted time to speak at the discretion of the Chair. Any additional public comments will be heard at the conclusion of the meeting. While members of the public are welcome to address the Board, under the Brown Act, Board members may not deliberate or take action on items not on the agenda.\)](#)

10:14 A.M. Public Comment Opened

Public Speakers:

Cactus Pete

Thomas Ells

Michelle Miller

Mary Morrison

Rachel Bell

James Savage

Roseanne Snyder

Shelby Crosby

Vanessa Richard

Hannah

John Jenkel

Scott Wagner

10:38 A.M. Public Comment Closed

IV. [PUBLIC COMMENT ON CLOSED SESSION ITEMS](#)

10:38 A.M. Public Comment Opened

Public Speakers:

Scott Wagner

10:40 A.M. Public Comment Closed

10:41 A.M. The Board recessed to Closed Session.

V. [CLOSED SESSION CALENDAR](#)

4:35 P.M. County Counsel Bruce Goldstein reported on Closed Session Items 1 through 5.

1. [The Board of Supervisors will consider the following in closed session: Public Employee Performance Evaluation – Transportation and Public Works Director \(Government Code Section 54957\(b\)\(1\)\).](#)

No reportable action. Direction was given to staff.

2. [The Board of Supervisors will consider the following in closed session: Public Employee Performance Evaluation – County Counsel \(Government Code Section 54957\(b\)\(1\)\).](#)

No reportable action. Direction was given to staff.

3. [The Board of Supervisors will consider the following in closed session: Conference with Legal Counsel – Existing Litigation – Drake et al v County of Sonoma et al \(3:18-cv-01955-VC\) \(Government Code Section 54956.9\(d\)\(1\)\).](#)

This item was withdrawn.

4. [The Board of Supervisors will consider the following in closed session: Public Employee Performance Evaluation – Economic Development Board \(Government Code Section 54957\(b\)\(1\)\).](#)

No reportable action. Direction was given to staff.

5. [The Board of Supervisors, the Board of Directors of the Water Agency, the Board Commissioners of the Community Development Commission, and the Board of Directors of The Agricultural Preservation and Open Space District will consider the following in closed session: Conference with Labor Negotiators: Christina Cramer/Carol Allen, County of Sonoma, and Rick Bolanos/Heather Coffman, Liebert Cassidy & Whitmore. Employee Organizations: All. Unrepresented employees: All, including retired employees. \(Government Code section 54957.6\).](#)

No reportable action. Direction was given to labor negotiators.

6. [RECONVENE FROM CLOSED SESSION](#)

Supervisors Present: David Rabbitt, Shirlee Zane, James Gore, Lynda Hopkins

Supervisors Absent: Susan Gorin

Staff Present: Sheryl Bratton, County Administrator and Bruce Goldstein, County Counsel

7. [REPORT ON CLOSED SESSION](#)

4:35 P.M. County Counsel Bruce Goldstein reported on Closed Session Items 1 through 5.

8. [ADJOURNMENT](#)

4:36 P.M. The Board adjourned the meeting in the memory of Lisa "Willow" DiCenzo.

The meeting was adjourned to November 13, 2018, at 8:30 A.M.

Respectfully submitted,

Kay Lowtrip,
Chief Deputy Clerk of the Board

NOTE: The next Regular meeting will be held on November 13, 2018, at 8:30 a.m.



County of Sonoma Agenda Item Summary Report

Clerk of the Board
575 Administration Drive
Santa Rosa, CA 95403

Agenda Item Number: 17
(This Section for use by Clerk of the Board Only.)

To: Board of Supervisors

Board Agenda Date: November 13, 2018

Vote Requirement: Majority

Department or Agency Name(s): Board of Supervisors

Staff Name and Phone Number:

Supervisor David Rabbitt, (707) 565-2241

Supervisorial District(s):

Second

Title: Disbursement of Fiscal Year 2018-2019 Second District Community Investment Fund Grant Awards

Recommended Actions:

Approve Community Investment Fund grant awards and Authorize the County Administrator, or designee, to execute an agreement with the following non-profit entities for advertising and economic development efforts for FY 2018-2019: Children's Museum of Sonoma County, \$2,500; Operation Access, \$500; Petaluma Arts Council, \$2,500; Petaluma Museum Association, \$2,000; Sonoma County Farm Trails, \$5,000; and Sonoma County Pride for the LGBTQI Pride Summer Celebration 2019, \$1,000.

Executive Summary:

Community Non-Profit Grants for Local Events, Organizations, and Economic Development Grants of the Community Investment Fund Policy provides grant allocations to each Supervisor, to be distributed at the Supervisor's discretion. The Second District has reviewed the applications and wishes to recommend the following FY 2018-2019 grant awards:

- 1.) Children's Museum of Sonoma County for an awareness and promotion campaign to increase visitation; grant award of \$2,500.
- 2.) Operation Access for advertising for the Healthy Spirits 25th Anniversary Celebration; grant award of \$500.
- 3.) Petaluma Arts Council for marketing and promotion to support upcoming art exhibits; grant award of \$2,500.
- 4.) Petaluma Museum Association for advertising to support events and exhibits showcasing the local history; grant award of \$2,000.
- 5.) Sonoma County Farms Trails to support marketing and promotion for the upcoming Fall, Holiday and Spring Farm Trails Tours throughout Sonoma County; grant award of \$5,000.
- 6.) Sonoma County Pride to support the 2019 Sonoma County LGBTQI Pride Summer Celebration; grant award of \$1,000.

Discussion:

The Sonoma County Community Investment Fund grant program utilizes a portion of the Transient Occupancy Tax (TOT) to encourage tourism, economic development, and community engagement through a variety of grant award and funding avenues. The program provides various grants to community non-profits for advertising and economic development events and the county as a visitor destination with the goal of advancing economic growth through tourism. Additionally, the program provides grants to promote agricultural promotion as well as address impacts on safety due to tourism. The program provides funding to the Regional Parks Department as well as the Economic Development Department and a number of other county department activities, all with the focus of encouraging tourism and awareness of Sonoma County.

The Community Investment Fund Policy is divided into different categories. The Board established the Local Events, Organizations, and Economic Development category to assist small cultural, artistic, and countywide events and organizations as well as events occurring during the off peak tourism season (November 15 through April 15) with funding for advertising and economic development efforts that promote Sonoma County and encourage visitors to frequent the county throughout the entire year. Funding for these events and organizations is provided at the discretion of each Supervisorial District based on an overall allocation of \$250,000 divided equally across each district. Events and organizations make requests throughout the year to the Supervisorial District in which their event/organization exists.

Funds will be distributed upon approval of these awards by the Board of Supervisors and execution of the Community Investment Fund grant agreement (contract) by the entity. The contracts will be executed by the County Administrator, or designee. The contracts will require the County seal on promotional materials produced using the grant award and will require submission to the County Administrator's Office of advertising and promotional activity receipts up to the total amount of the grant award.

Activities performed utilizing Community Investment Program grants provided to non-profits will be consistent with Government Code Section 26227.

Prior Board Actions:

Strategic Plan Alignment Goal 2: Economic and Environmental Stewardship

Grant funds allow non-profit partners to advertise and grow local events and encourage tourism thereby promoting economic development and growth.

Fiscal Summary			
Expenditures	FY 18-19 Adopted	FY 19-20 Projected	FY 20-21 Projected
Budgeted Expenses	13,500		
Additional Appropriation Requested			
Total Expenditures	13,500		
Funding Sources			
General Fund/WA GF			
State/Federal			
Fees/Other	13,500		
Use of Fund Balance			
Contingencies			
Total Sources	13,500		
Narrative Explanation of Fiscal Impacts:			
Funds are included in the FY 2018-2019 budget.			
Staffing Impacts			
Position Title (Payroll Classification)	Monthly Salary Range (A – I Step)	Additions (Number)	Deletions (Number)
Narrative Explanation of Staffing Impacts (If Required):			
N/A			
Attachments:			
None			
Related Items "On File" with the Clerk of the Board:			
Community Investment Fund Policy			



County of Sonoma Agenda Item Summary Report

Clerk of the Board
575 Administration Drive
Santa Rosa, CA 95403

Agenda Item Number: 18
(This Section for use by Clerk of the Board Only.)

To: Board of Supervisors

Board Agenda Date: November 13, 2018

Vote Requirement: Majority

Department or Agency Name(s): Board of Supervisors

Staff Name and Phone Number:

Supervisor Shirlee Zane, 565-2241

Supervisorial District(s):

Third

Title: Disbursement of Fiscal Year 2018-2019 Third District Community Investment Fund Grant Awards

Recommended Actions:

Approve Community Investment Fund grant awards and Authorize the County Administrator, or designee, to execute an agreement with the following non-profit entities for advertising and economic development efforts for FY 2018-2019:

Sonoma County Pride - Sonoma County LGBTQI Pride Summer Celebration, \$500.

Lo Cien Sonoma County - Voter Education program, State of Latino Community forum, monthly forums and events, \$2,000.

Children's Museum of Sonoma County – Children's Museum of Sonoma County promotion and advertising, \$2,000.

Buck Institute for Research on Aging - North Bay Science Discovery Day 2018, \$300.

Operation Access - Healthy Spirits 25th Anniversary Celebration, \$500.

6th Street Playhouse - 2018-19 Season of 6th Street Playhouse, \$2,000.

Santa Rosa Symphony - 2018–2019 season of Free Concerts for Youth, \$3,000.

Sonoma County Bicycle Coalition – Bicycle safety programs, \$2,500.

Latino Health Forum – Latino Health Forum, \$750.

Executive Summary:

Community Non-Profit Grants for Local Events, Organizations, and Economic Development Grants of the Community Investment Fund Policy provides grant allocations to each Supervisor, to be distributed at the Supervisor's discretion. The Third District has reviewed the applications and wishes to recommend the following FY 2018-2019 grant awards:

- 1.) Sonoma County Pride for advertising and promotion Sonoma County LGBTQI Pride Summer Celebration; grant award of \$500.

- 2.) Lo Cien Sonoma County for advertising, promotion and support of the Voter Education program, State of Latino Community forum, monthly forums and events; grant award of \$2,000
- 3.) Children's Museum of Sonoma County – for advertising and promotion of Children's Museum of Sonoma County; grant award of \$2,000.
- 4.) Buck Institute for Research on Aging for advertising and promotion of the North Bay Science Discovery Day 2018; grant award of \$300.
- 5.) Operation Access for advertising, promotion and support of the Healthy Spirits 25th Anniversary Celebration; grant award of \$500.
- 6.) 6th Street Playhouse for advertising and promotion of the 2018-19 Season of 6th Street Playhouse; grant award of \$2,000.
- 7.) Santa Rosa Symphony to support the 2018–2019 season of Free Concerts for Youth; grant award of \$3,000.
- 8.) Sonoma County Bicycle Coalition to support bicycle safety programs; grant award of \$2,500.
- 9.) Latino Health Forum for advertising, promotion and support of the Latino Health Forum; grant award of \$750.

Discussion:

The Sonoma County Community Investment Fund grant program utilizes a portion of the Transient Occupancy Tax (TOT) to encourage tourism, economic development, and community engagement through a variety of grant award and funding avenues. The program provides various grants to community non-profits for advertising and economic development events and the county as a visitor destination with the goal of advancing economic growth through tourism. Additionally, the program provides grants to promote agricultural promotion as well as address impacts on safety due to tourism. The program provides funding to the Regional Parks Department as well as the Economic Development Department and a number of other county department activities, all with the focus of encouraging tourism and awareness of Sonoma County.

The Community Investment Fund Policy is divided into different categories. The Board established the Local Events, Organizations, and Economic Development category to assist small cultural, artistic, and countywide events and organizations as well as events occurring during the off peak tourism season (November 15 through April 15) with funding for advertising and economic development efforts that promote Sonoma County and encourage visitors to frequent the county throughout the entire year. Funding for these events and organizations is provided at the discretion of each Supervisorial District based on an overall allocation of \$250,000 divided equally across each district. Events and organizations make requests throughout the year to the Supervisorial District in which their event/organization exists.

Funds will be distributed upon approval of these awards by the Board of Supervisors and execution of the Community Investment Fund grant agreement (contract) by the entity. The contracts will be executed by the County Administrator, or designee. The contracts will require the County seal on promotional materials produced using the grant award and will require submission to the County Administrator's Office of advertising and promotional activity receipts up to the total amount of the grant award.

Activities performed utilizing Community Investment Program grants provided to non-profits will be consistent with Government Code Section 26227.

Prior Board Actions:

Strategic Plan Alignment Goal 2: Economic and Environmental Stewardship

Grant funds allow non-profit partners to advertise and grow local events and encourage tourism thereby promoting economic development and growth.

Fiscal Summary

Expenditures	FY 18-19 Adopted	FY 19-20 Projected	FY 20-21 Projected
Budgeted Expenses	13,550		
Additional Appropriation Requested			
Total Expenditures	13,550		

Funding Sources

General Fund/WA GF			
State/Federal			
Fees/Other	13,550		
Use of Fund Balance			
Contingencies			
Total Sources	13,550		

Narrative Explanation of Fiscal Impacts:

Funds are included in the FY 2018-2019 budget.

Staffing Impacts

Position Title (Payroll Classification)	Monthly Salary Range (A – I Step)	Additions (Number)	Deletions (Number)

Narrative Explanation of Staffing Impacts (If Required):

N/A

Attachments:
None.
Related Items "On File" with the Clerk of the Board:
Community Investment Fund Policy



County of Sonoma Agenda Item Summary Report

Clerk of the Board
575 Administration Drive
Santa Rosa, CA 95403

Agenda Item Number: 19
(This Section for use by Clerk of the Board Only.)

To: Board of Supervisors

Board Agenda Date: November 13, 2018

Vote Requirement: Majority

Department or Agency Name(s): Board of Supervisors

Staff Name and Phone Number:

Supervisor Gore, 565-2241

Supervisorial District(s):

Fourth

Title: Disbursement of Fiscal Year 2018-2019 Fourth District Community Investment Fund Grant Awards

Recommended Actions:

Approve Community Investment Fund grant awards and Authorize the County Administrator, or designee, to execute an agreement with the following non-profit entities for advertising and promotions activities for FY 2018-2019: California Indian Museum and Cultural Center – ACORN, \$1,000; Children’s Museum of Sonoma County – Campaign of Awareness, \$550; Cloverdale Arts Alliance – Friday Night Live on the Plaza, \$8,000; Los Cien, Sonoma County Inc. – State of the Latino Community Forum, \$700; Slow Food – Apples at the Airport, \$1,000; Sonoma County Farm Trails – tours and events, \$750; and Town of Windsor – Summer Nights on the Green, \$1,000.

Executive Summary:

Community Non-Profit Grants for Local Events, Organizations, and Economic Development Grants of the Community Investment Fund Policy provides grant allocations to each Supervisor, to be distributed at the Supervisor’s discretion. The Fourth District has reviewed the applications and wishes to recommend the following FY 2018-2019 grant awards:

- 1.) California Indian Museum and Cultural Center for the advertising and promotion of ACORN; grant award of \$1,000.
- 2.) Children’s Museum of Sonoma County for the advertising and promotion of the Campaign of Awareness; grant award of \$550.
- 3.) Cloverdale Arts Alliance for the advertising and promotion of Friday Night Live on the Plaza; grant award of \$8,000.
- 4.) Los Cien, Sonoma County Inc. for the advertising and promotion of the State of the Latino community forum; grant award of \$700.
- 5.) Slow Food for the advertising and promotion of Apples at the Airport; grant award of \$1,000.
- 6.) Sonoma County Farm Trails for the advertising and promotion of the 2018/2019 tours and events; grant award of \$750.

7.) Town of Windsor for the advertising and promotion of Summer Nights on the Green; grant award of \$1,000.

Discussion:

The Sonoma County Community Investment Fund grant program utilizes a portion of the Transient Occupancy Tax (TOT) to encourage tourism, economic development, and community engagement through a variety of grant award and funding avenues. The program provides various grants to community non-profits for advertising and economic development events and the county as a visitor destination with the goal of advancing economic growth through tourism. Additionally, the program provides grants to promote agricultural promotion as well as address impacts on safety due to tourism. The program provides funding to the Regional Parks Department as well as the Economic Development Department and a number of other county department activities, all with the focus of encouraging tourism and awareness of Sonoma County.

The Community Investment Fund Policy is divided into different categories. The Board established the Local Events, Organizations, and Economic Development category to assist small cultural, artistic, and countywide events and organizations as well as events occurring during the off peak tourism season (November 15 through April 15) with funding for advertising and economic development efforts that promote Sonoma County and encourage visitors to frequent the county throughout the entire year. Funding for these events and organizations is provided at the discretion of each Supervisorial District based on an overall allocation of \$250,000 divided equally across each district. Events and organizations make requests throughout the year to the Supervisorial District in which their event/organization exists.

Funds will be distributed upon approval of these awards by the Board of Supervisors and execution of the Community Investment Fund grant agreement (contract) by the entity. The contracts will be executed by the County Administrator, or designee. The contracts will require the County seal on promotional materials produced using the grant award and will require submission to the County Administrator's Office of advertising and promotional activity receipts up to the total amount of the grant award.

Activities performed utilizing Community Investment Program grants provided to non-profits will be consistent with Government Code Section 26227.

Prior Board Actions:

Awarded FY 2018-2019: 08/14/2018 and 09/18/2018 Local Events, Organizations, and Economic Development grants

Strategic Plan Alignment Goal 2: Economic and Environmental Stewardship

Grant funds allow non-profit partners to advertise and grow local events and encourage tourism thereby promoting economic development and growth.

Fiscal Summary			
Expenditures	FY 18-19 Adopted	FY 19-20 Projected	FY 20-21 Projected
Budgeted Expenses	13,000		
Additional Appropriation Requested			
Total Expenditures	13,000		
Funding Sources			
General Fund/WA GF			
State/Federal			
Fees/Other	13,000		
Use of Fund Balance			
Contingencies			
Total Sources	13,000		
Narrative Explanation of Fiscal Impacts:			
Funds are included in the FY 18/19 budget.			
Staffing Impacts			
Position Title (Payroll Classification)	Monthly Salary Range (A – I Step)	Additions (Number)	Deletions (Number)
Narrative Explanation of Staffing Impacts (If Required):			
N/A			
Attachments:			
None.			
Related Items “On File” with the Clerk of the Board:			
Community Investment Fund Policy			



County of Sonoma Agenda Item Summary Report

Clerk of the Board
575 Administration Drive
Santa Rosa, CA 95403

Agenda Item Number: 20
(This Section for use by Clerk of the Board Only.)

To: Board of Supervisors

Board Agenda Date: November 13, 2018

Vote Requirement: 4/5

Department or Agency Name(s): County Counsel, County Administrator, Health Services

Staff Name and Phone Number:

Michelle Arellano (707) 565-2431
Jennifer C. Klein (707) 565-2421
Barbie Robinson (707) 565-7876

Supervisorial District(s):

All

Title: Solid Waste Independent Hearing Panel compensation and proposed dissolution; adoption of procedures governing appointment of Hearing Officer

Recommended Actions:

(1) Adopt a procedure to appoint a Solid Waste Independent Hearing Officer to hear local appeals for solid waste permitting and enforcement issues; (2) Adopt a resolution setting per diem compensation for Solid Waste Independent Hearing Panel members service, and approving retroactive reimbursement to 2016-17; (3) Disband the Solid Waste Independent Hearing Panel; (4) Adopt a resolution rescinding Resolution No. 92-0156, which established the Panel in 1992; and (5) authorize staff to recruit hearing officers.

Executive Summary:

This item establishes a local appeal procedure for actions of the Solid Waste Local Enforcement Agency (LEA). It recommends that the County change its appeal process from a hearing panel model to a hearing officer model and that the County adopt procedures for appointing one or more hearing officers and adopt qualifications that a hearing officer is required to meet. As an alternative, the Board could take no action, thus retaining the current three-person hearing panel model. This item also expressly authorizes and sets per diem compensation for Solid Waste Independent Hearing Panel members past service, and in the event the panel is not disbanded, ongoing service. This item also authorizes staff to recruit for hearing officers. Under state law the Board of Supervisors may appoint hearing officers after adopting qualifications that the hearing officer is required to meet.

Discussion:

In 1992, the California Integrated Waste Management Board (currently CalRecycle) certified the Department of Health Services, Environmental Health and Safety Section, as the Solid Waste Local

Enforcement Agency (LEA) for Sonoma County. The Local Enforcement Agency enforces California state solid waste laws and regulations pertaining to permitting and enforcement at solid waste facilities.

The California Public Resource Code and California Code of Regulations require the LEA to have an independent hearing panel or a hearing officer. (Public Resource Code § 44308; California Code of Regulations Title 14, § 18060). The hearing panel or hearing officer acts as the local appeals body for solid waste permitting and enforcement issues, such as denial, suspension, or revocation of a permit, challenges to recommended permit conditions, enforcement actions against unpermitted facilities and/or other enforcement actions, as well as the LEA's failure to act. The hearing panel or hearing officer holds hearings upon request made by the person subject to the action or by a person alleging that the Local Enforcement Agency failed to act, and decides whether to grant or deny relief. Decisions of the hearing panel or hearing officer may then be appealed to the State Board (California Department of Resources Recycling and Recovery, "CalRecycle"). Hearing policy and procedures are to be developed at the local level, however if a hearing panel is utilized it must have three members, one of which must be a "technical expert with knowledge of solid waste management methods and technology," and one of which must be a "representative of the public at large." Historically, the Sonoma County Board of Supervisors ("Board") has chosen the option of an independent hearing panel and has made appropriate appointments and reappointments to this panel since 1992. The current panel expires in November 2019, after a four year term, per Public Resources Code 44308(b)(5).

Recommendations

1. Adopt Procedures to Permit Shift to Hearing Officer Model for Solid Waste Hearings.

Staff recommends that a hearing officer be appointed to hear solid waste hearings. That option is available if the governing body adopts procedures for making that appointment and has adopted qualifications that the hearing officer is required to meet. (Public Resource Code § 44308(d)).

Under state law, the procedural rules for conducting the hearing and making findings and decisions are essentially the same for a hearing panel or a hearing officer, except that a hearing officer can decide a dispute based on a single vote as opposed to a majority vote of the panel. Appropriate qualifications for a hearing officer would include a license to practice law in the State of California and subject matter expertise concerning solid waste issues.

Staff recommends that the Board adopt procedures to appoint a hearing officer, instead of a three member panel, under Public Resource Code § 44308(d) and California Code of Regulations Title 14, § 18060, and that the Board adopts the attached "PROCEDURES & QUALIFICATIONS FOR APPOINTMENT OF HEARING OFFICERS FOR HEARINGS ON MATTERS RELATED TO LOCAL ENFORCEMENT AGENCY PROCEEDINGS." If the Board adopts these procedures and so authorizes staff, then recruitment efforts to seek qualified individuals to be considered to serve as a hearing officer by the Board will be brought at a future meeting. In the event there are no qualified applicants, or if an appointed qualified hearing officer is unavailable for a requested hearing, the proposed procedures provide for use of an administrative law judge contracted through the State Office of General Services / Office of Administrative Hearings on a case-by-case basis. The County currently contracts with the State Office of General Services for independent hearing officers for code enforcement hearings.

Though originally established in 1992, the Panel convened for the first time only recently. In 2017, the panel heard two separate appeals, and a variety of issues have arisen triggering the proposal for change. First, due to the complexity of the issues, panel members devoted substantial amounts of time to the appeals. Except for the member of the Panel who is also a member of the Board of Supervisors, the other members are not presently compensated by the County for their service on the Panel. Second, in setting hearing dates, staff must coordinate the schedules of three panel members. This is very difficult to do while meeting the statutory requirement for expedited hearings. Thus, CalRecycle has generally advised that “Due to the appeal and hearing timeline constraints outlined in PRC 44310, CalRecycle recommends the use of a hearing officer.” Third, having a hearing officer will simplify hearing noticing somewhat, as a hearing officer is not a Brown Act body. Fourth, having a single, qualified hearing officer with a legal background will eliminate the need to provide separate legal staffing for the panel, significantly reducing the associated County Counsel legal assistance cost to the panel. For the two recently requested hearings, one of which was settled after a pre-hearing conference, cost for County Counsel’s time totaled approximately \$20,000.

The Clerk of the Board provided service to the Solid Waste Independent Hearing Panel. These services included scheduling, noticing, attending meetings of the Panel, preparing minutes, and general clerical duties. If a hearing officer model is adopted and the panel disbanded, clerical time currently spent preparing minutes of Panel meetings and hearings would not be required, however clerical staff time scheduling, noticing and assisting during the requested hearings would continue to be needed. Either the Clerk of the Board or the Local Enforcement Agency could provide any necessary clerical assistance to the hearing officer.

2. Set Per Diem Compensation For Service of Panel Members.

Under state law, panel members may receive a per diem and necessary expenses while conducting the hearing. For the Solid Waste Independent Hearing Panel, currently no per diem is set by the County’s Salary Resolution, or any other resolution. In order to permit existing members, except any member of the Panel who is also a member of the Board of Supervisors during the time of service on the Panel, to receive the per diem allowed under state law, staff includes a proposed resolution to set per diem compensation in the amount of \$125 per day, or \$75 per half day, of service on the Panel, and to reimburse qualified panel members for any actual expenses while conducting the hearing. For comparison, these amounts are consistent with amounts paid to Assessment Appeals Board members. A Solid Waste Independent Hearing Panel member who also serves on the Board of Supervisors may not qualify for the per diem or reimbursement because such member receives a county-funded salary during the time of service on the Panel and the county already covers costs – such as copy costs -- associated with such member’s service on the Panel, if any.

3. Disband Solid Waste Independent Hearing Panel

If the Board adopts the proposed procedures and qualifications for appointment of hearing officers, it is also recommended that the Board disband the Solid Waste Hearing Panel, and rescind Resolution No. 92-0156 which established the Solid Waste Hearing Panel in 1992. However, to ensure that there is a qualified decision maker or decision-making body in place at all times to hear an appeal, the proposed

actions to disband the panel and rescind the resolution that established it would only become effective upon the appointment of a qualified hearing officer.

Alternatives:

In the alternative, the Board may retain the current Solid Waste Independent Hearing Panel. The Board may also chose to set a per diem in a different amount, or to not set an amount at all, for the service of such panel members.

Prior Board Actions:

November 15, 2015, the Board appointed Greg Pirie, Tim Smith, and Supervisor James Gore to the Solid Waste Independent Hearing Panel. Resolutions No. 92-0156 (establishing Panel), 92-0470, 95-0265, 00-0474, 03-0575, 05-0904, and 11-0430 appointing panel members.

Strategic Plan Alignment Goal 1: Safe, Healthy, and Caring Community

Enforcement of solid waste laws and regulations further the goals of public safety and health.

Fiscal Summary

Expenditures	FY 18-19 Adopted	FY 19-20 Projected	FY 20-21 Projected
Budgeted Expenses	\$400		
Additional Appropriation Requested			
Total Expenditures	\$400		

Funding Sources

General Fund/WA GF	\$400		
State/Federal			
Fees/Other			
Use of Fund Balance			
Contingencies			
Total Sources	\$400		

Narrative Explanation of Fiscal Impacts:

The Solid Waste Hearing Panel participated in two hearings of one full day and one half day. Costs incurred by panel members that are eligible for reimbursement are \$400. There are sufficient appropriations in the Non-Departmental budget to cover these previously incurred costs. No further panel member per diem expenses will be incurred if the Board approves a changing to hearing officer model.

Hearing officers appointed by the County shall be paid at the hourly rate established by the California State Office of Administrative Hearings for administrative law judges who are available to local agencies to hear administrative hearings, or other negotiated rate necessary to retain a qualified hearing officer. (For example, for 2017-18, an administrative law judge retained through the Office of Administrative Hearings is paid \$270/per hour.) Because expenses are dependent on whether hearings are requested in any given year, and on the complexity and actual duration of a hearing, there is no way to predict annual expenses with accuracy.

Staffing Impacts

Position Title (Payroll Classification)	Monthly Salary Range (A – I Step)	Additions (Number)	Deletions (Number)

Narrative Explanation of Staffing Impacts (If Required):

Attachments:

Resolution Setting Per Diem Compensation for Members of the Solid Waste Independent Hearing Panel
 Resolution Rescinding Resolution No. 92-0156 Establishing A Solid Waste Hearing Panel.
 Attachment 1: PROCEDURES & QUALIFICATIONS FOR APPOINTMENT OF HEARING OFFICERS FOR HEARINGS ON MATTERS RELATED TO LOCAL ENFORCEMENT AGENCY PROCEEDINGS.

Related Items “On File” with the Clerk of the Board:

ATTACHMENT #1

PROCEDURES AND QUALIFICATIONS FOR APPOINTMENT OF HEARING OFFICERS FOR HEARINGS ON MATTERS RELATED TO LOCAL ENFORCEMENT AGENCY PROCEEDINGS

AS ADOPTED BY THE SONOMA COUNTY BOARD OF SUPERVISORS

DATE: November 13, 2018

1. Pursuant to the provisions of the California Public Resources Code (PRC) concerning activities of the Local Enforcement Agency (LEA), including but not limited to those provisions set forth in PRC Sections 44308, et seq., the Sonoma County Clerk of the Board of Supervisors shall determine, consistent with the requirements set forth below, a proposed hearing officer, whose qualifications shall be set forth and presented to the Board of Supervisors for consideration of appointment as a hearing officer.
2. A hearing officer approved by the Board of Supervisors shall conduct all proceedings in accordance with the applicable provisions set forth in the California Public Resources Code.
3. For consideration as a hearing officer in the above-described role, a person shall be licensed as a member of the State Bar of California for a minimum of eight years prior to appointment. The hearing officer may not have a conflict of interest, shall be independent of the "operating unit" as defined in Title 14, section 18011(a)(17) of the California Code of Regulations, and shall have appropriate legal, administrative or technical abilities in areas related to solid waste management and/or administrative law. Preference will be given to those with solid waste experience.
4. For consideration as a hearing officer, a person shall demonstrate experience and familiarity with the current law in the state of California concerning solid waste issues, and/or demonstrate experience in administrative law. Preference will be given to those with solid waste experience.
5. For consideration as a hearing officer, a person shall demonstrate to the satisfaction of the Clerk of the Board or his/her designee that the person possesses a judicial demeanor consistent with the impartial conduct of any proceedings.
6. The Board of Supervisors shall consider and take action on the recommendation received from the Clerk of the Board. Any such appointment shall be effective for two years unless earlier terminated by either party with 30 days' notice.
7. Additional hearing officers may be appointed who may serve on a rotational basis.
8. Hearing officers appointed by the County shall be paid at the hourly rate established by the California State Office of Administrative Hearings for administrative law judges who are available to local agencies to hear administrative hearings, or other negotiated rate necessary to retain a qualified hearing officer. If no County appointed hearing officer is available to conduct a hearing, the County may retain the services of an administrative law judge through the California State Office of Administrative Hearings on a case-by-case basis, as necessary, at the rate set by the State of California. In lieu of retaining an administrative law judge from the California State Office of Administrative Hearings the County may alternatively elect to retain, on a case by case basis, an appropriately qualified staff person of another California county or local agency to serve as a hearing officer.



County of Sonoma

State of California

Date: November 13, 2018

Item Number: _____
Resolution Number: _____



4/5 Vote Required

Resolution Of The Board Of Supervisors Of The County Of Sonoma, State Of California, Setting Per Diem Compensation for Members of the Solid Waste Independent Hearing Panel

Whereas, on behalf of the State of California, the County of Sonoma adopted Resolution No. 92-0156 on February 4, 1992, to establish a Solid Waste Independent Hearing Panel; and

Whereas, under Public Resources Code Section 44308, subsection (d), members of Solid Waste Independent Hearing Panels may receive per diem and necessary expenses while conducting hearings; and

Whereas, the Board of Supervisors has not previously set an amount or otherwise provided for compensation of members of the Solid Waste Independent Hearing Panel; and

Whereas, the Board of Supervisors desires to set a per diem amount for members of the Solid Waste Independent Hearing Panel, but excluding any member of the Board of Supervisors appointed to the Solid Waste Independent Hearing Panel;

Whereas, the Board of Supervisors finds that the per diem amount set herein is reasonable considering the complexity of the potential issues raised before the Solid Waste Independent Hearing Panels under solid waste law, and the qualifications and experience required of the Panel members; and

Whereas, the Board of Supervisor's intent is that the per diem amount set by this resolution be retroactively applicable to service of members of the Solid Waste Independent Hearing Panel, excluding any appointed member of the Board of Supervisors, provided during fiscal year, 2016-2017, and forward for so long as the Solid Waste Independent Hearing Panels is assembled.

Now, Therefore, Be It Resolved that each member of the Solid Waste Independent Hearing Panel, excluding any appointed member of the Board of Supervisors, shall receive one hundred twenty-five dollars (\$125) for each full day meeting of said panel attended by the member. Half-day meetings shall be compensated at the rate of

Resolution #

Date:

Page 2

seventy-five dollars (\$75), and shall be scheduled only to conduct deliberations on appeals under submission, to conclude hearings which could not be completed within one calendar day, or in the event there are too few appeals scheduled to fill a regular calendar day.

Be It Further Resolved that the Board of Supervisors hereby finds that each member of the Solid Waste Independent Hearing Panel, excluding any appointed member of the Board of Supervisors, shall receive reimbursement for necessary and actual expenses incurred by the member during the conduct of a hearing.

Supervisors:

Gorin:

Rabbitt:

Zane:

Hopkins:

Gore:

Ayes:

Noes:

Absent:

Abstain:

So Ordered.



County of Sonoma
State of California

Date: November 13, 2018

Item Number: _____
Resolution Number: _____



4/5 Vote Required

**Resolution Of The Board Of Supervisors Of The County Of Sonoma, State Of California,
Rescinding Resolution No. 92-0156
Establishing A Solid Waste Hearing Panel.**

Whereas, on behalf of the State of California, the County of Sonoma adopted Resolution No. 92-0156 on February 4, 1992, to establish a Solid Waste Hearing Panel; and

Whereas, it is the intent of the Board to disband and dissolve the Solid Waste Hearing Panel and, instead, appoint a Solid Waste Hearing Officer pursuant to Public Resource Code § 44308; and,

Now, Therefore, Be It Resolved on behalf of the State of California, after a duly noticed public hearing, the Board of Supervisors of the County of Sonoma resolves and finds as follows:

Resolution No. 92-0156 is hereby expressly rescinded in its entirety and the Solid Waste Independent Hearing Panel dissolved and disbanded. This action shall only become effective upon the initial appointment of a Solid Waste Hearing Officer pursuant to Public Resources Code Section 44308.

Supervisors:

Gorin: Rabbitt: Zane: Hopkins: Gore:

Ayes: Noes: Absent: Abstain:

So Ordered.



County of Sonoma Agenda Item Summary Report

Clerk of the Board
575 Administration Drive
Santa Rosa, CA 95403

Agenda Item Number: 21
(This Section for use by Clerk of the Board Only.)

To: Board of Supervisors

Board Agenda Date: November 13, 2018

Vote Requirement: 4/5

Department or Agency Name(s): County Administrator
Fire & Emergency Services

Staff Name and Phone Number:

Sheryl Bratton, 565-2241
Christopher Godley, 565-2052

Supervisorial District(s):

All

Title: Extend Proclamation of Local Emergency Due to the Sonoma Complex Fires

Recommended Actions:

Adopt a Resolution Extending the Proclamation of Local Emergency Issued on October 9, 2017, for another 30 Days Due to Damage Arising from the Complex Fires.

Executive Summary:

This item requests the Board of Supervisors adopt a resolution approving a 30-day extension of the October 9, 2017, Proclamation of a Local Emergency in the Sonoma County Operational Area due to the effects of the Complex Fires. The Complex Fires began on Sunday, October 8, 2017, causing extreme property damage and health and safety concerns. The County Administrator proclaimed the Existence of a Local Emergency on October 9, 2017, and the Board of Supervisors adopted Resolution No. 17-0389 ratifying that proclamation on October 10, 2017. The fires left a large debris field in their wake. The removal of debris from a wildfire disaster creates unique concerns due to the potential presence of hazardous materials and the large scale of the incident and will require significant resources to remove. As long as the residential and commercial fire debris remains on the ground, it poses an imminent and extensive threat to public health and safety, the environment (including creating serious concerns for water quality and supply due to the presence of hazardous materials and the damage to sewer service laterals), public infrastructure, and undamaged property. As required by Government Code section 8630, the Board must review the proclamation of local emergency every 30 days and determine if there is a need for continuing the local emergency.

Discussion:

The Complex Fires began on Sunday, October 8, 2017. In response, the Emergency Operations Center (EOC) was activated at approximately 12:00 a.m. on Monday, October 9, 2017, to assist with managing the impacts. In the early morning hours on Monday, the County issued advisory evacuation notices to various impacted areas of Sonoma County. Shelter was made available at various locations throughout the County, and first responders were actively engaged in multiple areas throughout the County as the complex fires' advanced.

The County Administrator/Director of Emergency Services issued a Proclamation of Existence of Local Emergency in Sonoma County Operational Area in the early morning hours of Monday, October 9, 2017, as soon as reports of quickly-moving fires and health and safety concerns arrived. Later that day, the County Administrator supplemented that Proclamation and requested state and federal assistance. The Board of Supervisors ratified the County Administrator's Proclamation of the Existence of a Local Emergency on October 10, 2017. California Government Code section 8630 of Article 14, Local Emergency, of Chapter 7 of the Emergency Services Act requires that the County review the need for continuing the local emergency at least once every 30 days until the governing body terminates the local emergency.

The scope of disaster caused by the fast-moving fire and widespread scale of the destruction instigated the Governor of the State of California to proclaim a State of Emergency (declaring eligibility for State assistance) and brought about the President of the United States to issue a Declaration of a Major Disaster for the State of California, making the Complex Fires eligible for Federal assistance. The Sonoma Complex Fires resulted in the most devastating wildfires in the history of the State of California. In Sonoma County alone, the fires caused the death of at least 24 people, charred 110,720 acres, destroyed 6,950 structures (including 5,143 housing structures), and displaced more than 100,000 Sonoma County residents.

The Sonoma Complex Fires left a large debris field in their wake, which creates unique removal concerns due to the potential presence of hazardous materials and the large scale of the incident and poses a threat to public health and safety. Debris cleanup has proceed via both public and private cleanup programs. The total number of properties included within the debris removal program was 4,888, including 3,674 properties that participated in the public-cleanup program, and 1,214 properties that participated in the private program.

Most properties are in the final stages of debris cleanup, however, approximately 722 properties have been evaluated by Cal OES for over-excavation and 385 determined eligible for backfilling.

The cleanup efforts in Sonoma County were aided by a relatively light rainy season. As long as the fire debris properties remain to be cleared on the ground, it poses an imminent and extensive threat to public health and safety, the environment (including creating serious concerns for water quality and supply due to the presence of hazardous materials and the damage to sewer service laterals), public infrastructure, and undamaged property.

Staff recommend that the Board adopt the attached Resolution finding that the severity and pervasiveness of the Sonoma Complex Fires disaster poses an ongoing and imminent threat to public safety and undamaged property that warrants the need to extend the local emergency as authorized by Government Code section 8630.

Prior Board Actions:

October 23, 2018: Board adopted Resolution No. 18-0450 Declaring the Need For Continuing The Local Emergency Pursuant to Government Code Section 8630 Due To The Sonoma Complex Fires

September 25, 2018: Board adopted Resolution No. 18-0395 Declaring the Need For Continuing The Local Emergency Pursuant to Government Code Section 8630 Due To The Sonoma Complex Fires

August 28, 2018: Board adopted Resolution No. 18-0337 Declaring the Need For Continuing The Local Emergency Pursuant to Government Code Section 8630 Due To The Sonoma Complex Fires

August 7, 2018: Board adopted Resolution No. 18-0301 Declaring the Need For Continuing The Local Emergency Pursuant to Government Code Section 8630 Due To The Sonoma Complex Fires

July 10, 2018: Board adopted Resolution No. 18-0266 Declaring the Need For Continuing The Local Emergency Pursuant to Government Code Section 8630 Due To The Sonoma Complex Fires

June 11, 2018: Board adopted Resolution No. 18-0248 Declaring the Need For Continuing The Local Emergency Pursuant to Government Code Section 8630 Due To The Sonoma Complex Fires

June 5, 2018: Board adopted Resolution No. 18-0224 Declaring the Need For Continuing The Local Emergency Pursuant to Government Code Section 8630 Due To The Sonoma Complex Fires

May 8, 2018: Board adopted Resolution No. 18-0161 Declaring the Need For Continuing The Local Emergency Pursuant to Government Code Section 8630 Due To The Sonoma Complex Fires

April 17, 2018: Board adopted Resolution No. 18-0131 Declaring the Need For Continuing The Local Emergency Pursuant to Government Code Section 8630 Due To The Sonoma Complex Fires

March 20, 2018: Board adopted Resolution No. 18-0095 Declaring the Need For Continuing The Local Emergency Pursuant to Government Code Section 8630 Due To The Sonoma Complex Fires

February 20, 2018: Board adopted Resolution No. 18-0068 Declaring the Need For Continuing The Local Emergency Pursuant to Government Code Section 8630 Due To The Sonoma Complex Fires

February 13, 2018: Board adopted Resolution NO. 18-0056 Declaring the Need For Continuing The Local Emergency Pursuant to Government Code Section 8630 Due To The Sonoma Complex Fires

January 23, 2018: Board adopted Resolution No. 18-0022 Declaring the Need For Continuing The Local Emergency Pursuant to Government Code Section 8630 Due To The Sonoma Complex Fires

December 29, 2017: Board adopted Resolution No. 17-0515 Declaring the Need For Continuing The Local Emergency Pursuant to Government Code Section 8630 Due To The Sonoma Complex Fires

December 5, 2017: Board adopted Resolution No. 17-0457 Declaring the Need For Continuing The Local Emergency Pursuant to Government Code Section 8630 Due To The Sonoma Complex Fires

November 7, 2017: Board adopted Resolution Modifying Resolution No. 17-0839 To Comply With Federal Assistance Requirements and Declaring the Need For Continuing The Local Emergency Pursuant to Government Code Section 8630 Due To The Sonoma Complex Fires.

October 10, 2017: Board adopted Resolution No. 17-0389 ratifying the County Administrator’s proclamation of the existence of a local emergency with the Sonoma County Operation Area.

Strategic Plan Alignment Goal 1: Safe, Healthy, and Caring Community

Fiscal Summary			
Expenditures	FY 18-19 Adopted	FY 19-20 Projected	FY 20-21 Projected
Budgeted Expenses			
Additional Appropriation Requested			
Total Expenditures			
Funding Sources			
General Fund/WA GF			
State/Federal			
Fees/Other			
Use of Fund Balance			
Contingencies			
Total Sources			
Narrative Explanation of Fiscal Impacts:			
Staffing Impacts			
Position Title (Payroll Classification)	Monthly Salary Range (A – I Step)	Additions (Number)	Deletions (Number)
Narrative Explanation of Staffing Impacts (If Required):			
Attachments:			
Related Items “On File” with the Clerk of the Board:			



County of Sonoma

State of California

Date: November 13, 2018

Item Number: _____
Resolution Number: _____

4/5 Vote Required

**RESOLUTION OF BOARD OF SUPERVISORS OF THE COUNTY OF SONOMA, STATE OF CALIFORNIA
DECLARING THE NEED FOR CONTINUING THE LOCAL EMERGENCY PURSUANT TO GOVERNMENT
CODE SECTION 8630 DUE TO THE SONOMA COMPLEX FIRES AND CONCURRENTLY EXTENDING THE
PROVISIONS OF CALIFORNIA PENAL CODE SECTION 396 PROHIBITING PRICE GOUGING IN TIMES
OF EMERGENCY FOR ANOTHER 30 DAYS**

WHEREAS, California Government Code section 8630 and Section 10.5, Chapter 10 of the Sonoma County Code, empowers the County Administrator to proclaim the existence of a local emergency when the county is affected or likely to be affected by a public calamity is subject to ratification by the Board of Supervisors at the earliest practicable time; and

WHEREAS, conditions of extreme peril to the safety of persons and property arose within the County caused by threat of the existence of multiple fires, referred to as the Sonoma Complex Fires, commencing on or about midnight on the 8th day of October, 2017, at which time the Board of Supervisors of the County of Sonoma was not in session; and

WHEREAS, the County Administrator of the County of Sonoma did proclaim the existence of a local emergency within the Sonoma County Operational Area on the 9th day of October, 2017 and then made another proclamation with a request that the Governor of the State of California make available California Disaster Act Assistance and seek all available forms of disaster assistance and relief programs, including a request for a Presidential Declaration of a Major Disaster; and

WHEREAS, the scope of disaster caused by the fast-moving and widespread scope of the destruction of the fires, including loss of many homes and evacuation of thousands of people, caused the Governor of the State of California to proclaim a State of Emergency and declare eligibility for Fire Management Assistance Grant and other relief programs; and

WHEREAS, the Federal Government made a Presidential Declaration of the existence of a major disaster for the State of California (FEMA-4344-DR), dated October 10, 2017, and related determinations and amendments; and

WHEREAS, on October 10, 2017, the Board of Supervisors of the County of Sonoma adopted Resolution No. 17-0389 ratifying the County Administrator's Proclamations of the existence of a local emergency relating to the Sonoma Complex Fires; and

Resolution #

Date:

Page 2

WHEREAS, California Government Code section 8630 of Article 14, Local Emergency, of Chapter 7 of the Emergency Services Act requires that the County review the need for continuing the local emergency at least once every 30 days until the local governing body terminates the local emergency; and

WHEREAS, the Sonoma Complex Fires resulted in the most devastating wildfires in the history of the State of California, causing the death of at least 24 people, charring 110,720 acres, destroying 6,950 structures (including 5,143 housing structures), and displacing thousands of Sonoma County residents; and

WHEREAS, the Sonoma Complex Fires left a large debris field in their wake, creating unique removal concerns due to the potential presence of hazardous materials and the large scale of the incident; and

WHEREAS, the total number of properties included within the debris removal program is 4,888, including 3,674 properties that participated in the public cleanup program, and 1,214 properties that participated in the private program; and

WHEREAS, most properties are in the final stages of debris clean-up, however, approximately 722 properties were evaluated for over-excavation and 385 determined eligible for backfilling; and

WHEREAS, as long as the fire debris properties remain to be cleared on the ground, it poses an imminent and extensive threat to public health and safety, the environment (including creating serious concerns for water quality and supply due to the presence of hazardous materials and the damage to sewer service laterals), public infrastructure, and undamaged property; and

WHEREAS, due to the severity and pervasiveness of the Sonoma Complex Fires disaster, there is an ongoing and imminent threat to public safety and undamaged property that support the need to continue the local emergency.

NOW, THEREFORE, IT IS HEREBY DECLARED that the Board of Supervisors hereby finds there is an ongoing and imminent threat to public safety and undamaged property that warrant the need to extend the local emergency as authorized by Government Code section 8630; and

IT IS FURTHER PROCLAIMED AND ORDERED that the local emergency ratified by Resolution No. 17-0389, as previously amended and extended by Resolution No. 17-0431 on November 7, 2017, and subsequently extended for a further 30 days by Resolution No. 17-0457 on December 5, 2017, and for a further 30 days by Resolution No. 17-0515 on December 29, 2017, and for a further 30 days by resolution No.18-0022 on January 23, 2018, and for a further 30 days by resolution No.18-0056 on February 13, 2018, and for a further 30 days by resolution No.18-0068 on February 27, 2018, for a further 30 days by resolution No.18-0095 on March 20, 2018, and for a further 30 days by resolution No.18-0131 on April 17, 2018, and for a further 30 days by resolution No.18-0161 on May 8, 2018, and for a further 30 days by resolution No.18-0224 on June 5, 2018, and for a further 30 days by resolution No.18-0248 on June 11, 2018, and for a further 30 days by resolution No.18-0266 on July 10, 2018, and for a further 30 days by resolution No.18-0301 on August 7, 2018, and for a

Resolution #

Date:

Page 3

further 30 days by resolution No.18-0337 on August 28, 2018, and for a further 30 days by resolution No.18-0395 on September 25, 2018, and for a further 30 days by resolution No.18-0450 on October 23, 2018 is hereby extended for another 30 days in accordance with Government Code section 8630 and shall continue in full force and effect as originally proclaimed by the County Administrator on October 9, 2017, and nothing contained herein shall be construed modify, invalidate, or otherwise affect any provision of said Proclamation of local emergency.

PASSED AND ADOPTED by the Board this 13th day of November, 2018.

Supervisors:

Gorin:

Rabbitt:

Zane:

Hopkins:

Gore:

Ayes:

Noes:

Absent:

Abstain:

So Ordered.



County of Sonoma Agenda Item Summary Report

Agenda Item Number: 21a
(This Section for use by Clerk of the Board Only.)

Clerk of the Board
575 Administration Drive
Santa Rosa, CA 95403

Board of Supervisors

November 13, 2018

Informational Only

County Administrator's Office

Michael Gossman, 565-2341

All

Recovery Update

Receive an update on the status of recovery operations, planning, seeking of funding opportunities, community engagement and status of recovery framework, following the October 2017 Sonoma Complex Fires.

The aftermath of the October 2017 Sonoma Complex Fires presents ongoing risks to the residents, property, and environment of Sonoma County. Office of Recovery and Resiliency staff provides the Board regular updates on recovery efforts, including debris removal and other structural developments; external funding efforts; relevant legislation; ongoing community engagement; and status of the Recovery and Resiliency Framework being prepared by the Office.

In the early morning hours of October 9, 2017, County staff activated the Emergency Operations Center in response to the Sonoma Complex Fires, which burned 173 square miles and destroyed over 7,000 structures, including 5,143 homes. During the response phase, the County began planning for the recovery from the fires. On December 19, 2017, the Board of Supervisors established the Office of Recovery and Resiliency (Office) with the mission to develop a strategy that addresses the immediate and long-term recovery and resiliency efforts needed to help Sonoma County rebuild and recover from the wildfires. This Office continues to actively pursue recovery efforts, and to work with other County departments, agencies, and districts to assist Sonoma County residents in the process of rebuilding.

In an effort to keep the Board and community informed about the most current developments in the County's recovery efforts, the Office prepares a standing agenda item for each Board meeting, typically included on the consent calendar. Each update includes information on: (1) Ongoing Recovery Efforts and Structural Changes; (2) Recovery Related External Funding Opportunities; (3) Legislative Update;

and (4) highlights of activities on the horizon (Looking Forward). New items and updated counts and figures are in bold.

1. Ongoing Recovery Efforts and Structural Changes

A. Debris Removal

1. Debris removal is in the final stages for both the Government-Sponsored Program and the Alternative Program (private debris removal). About 25 percent of property owners who lost homes opted to use a private contractor for debris removal.
2. Government-Sponsored Program:
 - A. Properties cleared by Army Corps of Engineers: 3,674
 - B. All properties returned to owners by County to start rebuilding
3. Private Debris Removal:
 - A. County: 767 residential properties accepted; 742 certified as finished and ready to rebuild
 - B. City: 450 properties accepted; 439 finished and ready to rebuild
4. USACE Hotline:

The U.S. Army Corps of Engineers in May 2018 stopped accepting new debris removal complaints on its hotline for Sonoma County. The Office of Recovery & Resiliency has assumed the role of receiving new debris complaints at 707-565-1222.
5. **Over-Excavation Program:**

The California Office of Emergency Services is working with the City of Santa Rosa and County to address over-excavation issues that occurred as part of the Government-Sponsored Debris Removal Program. For properties that meet Cal OES over-excavation criteria, the State's contractor is backfilling to appropriate elevations. **As of November 5, 2018, 722 property owners requested site assessments; 385 have been ruled eligible for program; 337 have been ruled ineligible; backfilling of 333 sites has been completed.** A variety of issues have impacted the pace of the project, including the discovery of structural ash, concrete footings, large pieces of concrete and large boulders that required removal prior to backfilling work.
6. Hazardous tree removal

On October 16, 2018, your Board approved a construction contract for removal of fire-damaged trees, stump grinding, pruning limbs and disposing of previously felled trees, located in the public right-of-way. County crews and contractors previously removed trees that posed an "imminent" threat to road use, and an arborist consultant identified trees to be removed as posing "extreme" or "high" risks along 90 miles of roads in burned areas of the County. The Contractor and the Transportation & Public Works Department will notice the property owners adjacent to the "extreme" or "high" risk trees that will be removed by either mail or hand delivered letters, and social media. The work is expected to begin in December 2018.

The contract for the removal of trees within private property and affecting the road right-of-way is scheduled to be advertised in November 2018, potentially being

awarded in January 2019 with work starting in March. Those dates are subject to change pending Right of Entry or bid issues.

B. Watershed Task Force

Sonoma County has been leading efforts by the Watershed Task Force to coordinate preparation for rainy season operations, storm patrols, and communications between public agencies and with community members. Erosion and sediment control and storm water pollution prevention is a critical focus, since the risks of flooding, erosion, sedimentation, mudslides, or similar hazards are increased for a few years after a wildfire.

The County and City of Santa Rosa each prepared corresponding brochures to inform property owners and contractors about their responsibilities and the resources available, and created tailored versions addressing vacant parcels and those under construction. Those brochures were mailed to property owners in the burn areas and have been distributed by staff, inspectors, and nonprofit partners in group meetings and during site visits. A summary of the information and downloadable PDFs of the brochures are accessible online at <https://www.sonomacountyrecovers.org/rain-ready/>

Through service contracts, the County has continued to support local nonprofits that are providing technical services and implementing Best Management Practices (BMPs) on private parcels that were affected by the October 2017 fires. These services aim to protect the burned watersheds and the County's streams and rivers by stabilizing areas with vulnerable exposed soils and/or damaged vegetation. County staff are in the process of developing a longer term approach to address these issues to establish a systematic way of evaluating the highest risk areas, maximize service delivery, and ensure sufficient resources to mitigate these risks in the future. The program request for longer term needs will be brought to the Board for consideration in December 2018.

Several of the Watershed Task Force agencies have been collaborating with local nonprofits, neighborhood groups, and individual landowners in the Mark West Creek watershed to assess post-fire conditions prior to the onset of the rainy season. Volunteer teams performed desktop analyses of maps and aerial imagery, arranged access with landowners, and made field observations using a consistent and repeatable protocol. These efforts are helping to document the present condition of the stream corridor. The observations will be repeated if large rainfall and runoff events occur this winter, to allow for comparisons and help guide recommendations for possible follow-up.

C. Emergency Alert & Warning Systems Tests

On September 10 and 12, the County conducted an alert and warning system exercise to evaluate our current emergency alert and warning systems. The tests involved SoCoAlert, the Federal Wireless Emergency Alert (WEA) system, and the Emergency Alert Systems (EAS).

1. The SoCoAlert system contacted those registered in the system as well as landline phone numbers in the 911 database – a total of 290,000 numbers were attempted. There was a

51% success rate for delivering a message to a person or an answering machine. SoCoAlert now has more than 50,000 subscribers.

2. The WEA alert was sent in English and Spanish to five geographical areas (Guerneville, Glen Ellen/Kenwood, Healdsburg, Penngrove, Roseland). Over 3,600 people who received the alert completed a survey, which highlighted limited geo targeting abilities and that the two major carriers (AT&T and Verizon) have different methods for distributing WEAs.
3. The EAS message played on local radio and television stations.

Staff will evaluate how County can improve the effectiveness of these systems including better data from the 911 database, and working with state and federal agencies to improve the targeting and reach of the telecommunications providers in the WEA system.

D. Renewal Enterprise District and Build/Rebuild Ad Hoc Update

The Renewal Enterprise District (RED) is a partnership between the County and City of Santa Rosa to provide financing and regulatory certainty for housing projects and supportive infrastructure within targeted development areas of Sonoma County. Both the Board of Supervisors and the City Council authorized moving forward with development of a Joint Powers Authority (JPA) to establish the RED.

RED seeks to regionalize housing production, pool and leverage financing and funding, share risks and benefits of development in new ways, streamline environmental review while providing confidence in good projects, and put equity, affordability and climate solutions in the center of our local economic strategies. RED will build on existing regional planning efforts, and focus its regulatory and financial incentives on developments within locally designated employment investment and priority development areas.

E. Rebuilding Permits

1. County has issued **653 building permits for homes as of November 5; 229 permits are in process; 19 homes have been finished.** For latest numbers, go to <http://sonomacounty.ca.gov/PRMD/Administration/Rebuilding-Permits-Data/>
2. City of Santa Rosa has issued **1,046 building permits for homes as of November 5; 258 permits are in process; 43 homes have been finished.** For latest numbers, go to <https://www.srcity.org/2675/Rebuilding>

2. Recovery-Related External Funding Opportunities

A. Disaster Recovery Consulting Services Agreement

On July 10, 2018, your Board authorized the County Administrator to execute the Agreement for Consulting Services with Horne, LLP (Consultant) for as-needed disaster recovery consulting services and grants management support. Your Board also authorized the County Administrator, or designee(s), to issue and execute Task Orders per disaster recovery funding stream, up to total amounts not to exceed those specified in the Agreement. The Office of Recovery and Resiliency is developing the first Task Orders for the following activities:

1. CDBG-DR General Pre-Award Activities (capacity assessment, unmet needs assessment, attend community meetings, meet with key leaders and staff, provide trainings, coordinate with State)
2. FEMA PA general support as needed. Consultant may assist with other recovery-related external funding needs as well.

B. Community Development Block Grant – Disaster Recovery

Announcement of \$212 million: On April 10, 2018, the U.S. Department of Housing and Urban Development (HUD) announced that California would be receiving \$212 million to support long-term disaster recovery through the Community Development Block Grant – Disaster Recovery (CDBG-DR) program, including \$124 million for unmet disaster recovery needs, and \$88 million for preparedness and mitigation.

Requirements of \$124 million: The Federal Register governing the \$124 million portion for unmet disaster recovery needs was issued on August 20, 2018. At least 80% of the allocation (\$99 million) must address unmet disaster needs within the HUD-identified most impacted and distressed areas identified as: Sonoma and Ventura Counties, and zip codes 93108, 94558, 95422, 95470, and 95901. The California Department of Housing and Community Development (HCD), as Grantee and receiver of the funds, must submit an Action Plan to HUD by December 18, 2018, detailing the proposed use of all funds. HCD must assess community impacts and unmet needs to guide the development and prioritization of planned recovery activities, of which 70% must be used to support activities benefitting low- and moderate- income persons. Funds must primarily address unmet housing needs.

Current Status: HCD held a public meeting on October 2, 2018, in Santa Rosa to introduce the draft action plan and receive initial comments. They are required to hold a public comment period for no less than 30 days before finalizing and submitting their Action Plan. HCD's current proposed plan includes a budget of \$47.6 million for an owner-occupied housing program, \$66.7 million for a multifamily housing program, \$3.5 million for a FEMA PA match program, and \$6.2 million for administration. The Office of Recovery and Resiliency and the Community Development Commission, along with other community partners, are continuing to collaborate with HCD regarding the proposed programs for the action plan to align eligible unmet needs found throughout the County with the ultimate use of the funds.

C. FEMA Hazard Mitigation Grant Program

Hazard Mitigation Grant Program (HMGP) for DR-4344 and DR-4353: The October 2017 fires are also known as DR-4344, and the December 2017 Southern California fires are known as DR-4353. Both became Presidential Disaster Declarations, and as a result they generated Federal Emergency Management Agency (FEMA) HMGP funding. DR-4344 had \$333 million in HMGP available statewide, with applications due July 2 and September 4. DR-4353 had \$56 million in HMGP available statewide, with applications due September 4. County Departments and Districts submitted 20 grant applications to the California Office of Emergency Services (Cal OES) for this program. The County's submitted HMGP applications are summarized below.

The countywide Grant Steering Committee worked with Departments and Districts to prioritize feasible grant applications based on success criteria, match funding sources, and leadership priorities. Each application competes against the others – even with the significant funding this is anticipated to be highly competitive. All Sonoma County applications will compete against one another. For those applications that did not move forward under FEMA HMGP, the Grant Steering Committee will seek appropriate alternative funding sources.

DR-4344 Round 1 HMGP Applications - Submitted on July 2

- 8 applications submitted
 - \$17.4 million in total project costs (\$13.1 million in federal share, \$4.3 million in local match). \$500,000 in general fund match.
 - Applications submitted by Community Development Commission (1), General Services (1), Sonoma County Water Agency (3), and Transportation and Public Works (3)

DR-4353 HMGP Applications – submitted on September 4

- 1 application submitted
 - \$850,000 in total project cost (\$637,500 in federal share, \$212,500 in local match). \$212,500 in general fund match.
 - Application submitted by Fire and Emergency Services (1)

DR-4344 Round 2 HMGP Applications – submitted on September 4

- 11 applications submitted
 - \$21.4 million in total project costs (\$16 million in federal share, \$5.4 million in local match). \$4.5 million in general fund match.
 - Applications submitted by Fire and Emergency Services (1), General Services (1), Information Systems Department (1), Regional Parks (1), Permit Sonoma (4), Sonoma Water (1), and Transportation and Public Works (2)

The next steps are for Cal OES to complete its review of the applications and determine which to submit to FEMA for review and final approval. All projects receiving HMGP funding must be completed within three years from the date of award.

HMGP for DR-4382: The 2018 wildfires in Lake and Shasta County have become known as DR-4382, and also became a Presidential Disaster Declaration. This opened up HMGP funding and Notices of Interest (NOI) were due October 5, 2018. The Information Systems Department submitted 4 NOIs, and Sonoma Water submitted one NOI.

1. **ISD: Hardening of Wireless Communication Infrastructure, \$400,000 total project cost**
2. **ISD: Critical Facility Power Retrofit, \$100,000 total project cost**
3. **ISD: Critical Facility Redundant Power Feed, \$250,000 total project cost**
4. **ISD: Critical Facility Redundant Internet Feed, \$100,000 total project cost**
5. **Sonoma Water: Sonoma Water Standby Power, \$500,000 total project cost**

D. FEMA Public Assistance

The Disaster Finance Team (consisting of participants from the Auditor-Controller Treasurer-Tax Collector, County Administrator's Office, and County Counsel) is working with FEMA and

Cal OES to claim reimbursement for response and recovery costs associated with the October 2017 fires, as well as repair/replacement costs for damages sustained to County property that are not covered by the County's insurance policies. These claims are being submitted through the FEMA Public Assistance Program.

As of July 27, 2018, the Disaster Finance Team estimates the County's total disaster related costs qualifying for FEMA's Public Assistance Program will be approximately \$37M, of which we anticipate the County will be reimbursed approximately \$36M over the next 2 to 5 years. FEMA has obligated 13 of the 22 projects and the County has received \$9.1M in expedited reimbursement funding and \$246K for small permanent projects managed by Regional Parks and Transportation and Public Works.

E. Economic Development Administration – Disaster Supplemental Funding

Economic Development Administration (EDA) has an open funding opportunity to award grants to eligible entities to address economic challenges in disaster-impacted areas.

On **October 12, 2018**, the County's Economic Development Board submitted a **full grant application** to the EDA to conduct design/engineering for broadband in specific unserved rural areas of the County. This project was developed with the Office of Recovery and Resiliency, Department of Transportation and Public Works, and Information Systems Department. The submitted application is for \$605,500 to complete the design, engineering, and feasibility analysis of broadband in select locations.

Additional potential projects are being considered, including the following:

Project 1 - Revolving Loan Fund to provide credit to Sonoma County entrepreneurs traditionally excluded or denied loans from mainstream financial institutions.

Project 2 - Regional Construction and Trades Training Center.

Project 3 - AgTech Incubator for local agriculture and food/beverage manufacturing.

F. CAL FIRE Grants for Fire Prevention

The CAL FIRE Fire Prevention grant program, funded by the California Climate Investments (CCI) fund, aims to reduce the risk of wildland fires to habitable structures and communities. CAL FIRE opened the Fire Prevention program for FY 18-19 applications on October 17, 2018, with applications due December 19. The Office of Recovery is tracking this opportunity and coordinating with applicable County Departments and partners to consider applications. For more information see: http://calfire.ca.gov/fire_prevention/firepreventiongrants

In Summer 2018 CAL FIRE opened the Fire Prevention program for FY 17-18. Sonoma County applied for and was awarded the following grant application:

1. Northwest Roadway Safety, Fuels Reduction, and Community Chipper and Engagement Project. Transportation and Public Works is lead, in partnership with Fire and Emergency Services and Fire Safe Sonoma, Inc. Total: \$1,237,541; CAL FIRE \$1,082,969; Match: \$154,572

- a. Match source: \$131,300 is from General Fund FY 2018 set aside; \$23,272 from in-kind volunteer labor tracked by Fire Safe Sonoma.

G. Community Planning Assistance for Wildfire

The Community Planning Assistance for Wildfire (CPAW) program works with communities to reduce wildfire risk through improved land use planning. Applications were due October 5, 2018, and selected communities receive planning assistance at no cost. Permit Sonoma, Fire and Emergency Services, and the Office of Recovery and Resiliency worked together to submit an application. If awarded, the CPAW program would provide planning technical expertise throughout 2019 for our community's wildfire planning priorities. For examples of CPAW projects, go to <https://planningforwildfire.org/community-projects/>.

H. California Department of Fish and Wildlife Proposition 1 and Proposition 68 funding

On November 5, 2018, the California Department of Fish and Wildlife opened its solicitation for FY18-19 Restoration Grants funded by Proposition 1 and Proposition 68. Applications are due December 18, 2018. Eligible projects relate to climate resiliency, adaptation, wildfire watershed recovery, and other restoration priorities. For more information go to: <https://wildlife.ca.gov/Conservation/Watersheds/Restoration-Grants>

I. California Wildlife Conservation Board Proposition 68 funding

The California Wildlife Conservation Board anticipates that it will solicit grant applications for Proposition 68 funding in January 2019. They will seek projects related to climate resiliency, working landscapes, enhanced public access, biodiversity, and other State Wildlife Action Plan priorities. The Office of Recovery and Resiliency is tracking this opportunity.

J. CAL FIRE Grants for Forest Health

On October 1, 2018, CAL FIRE opened the grant solicitation period for the Forest Health Program. This program is funded through the California Climate Investments (CCI), and projects are sought that proactively restore forest health to reduce greenhouse gases, protect upper watersheds, promote long-term storage of carbon, minimize the loss of forest carbon from large, intense wildfires, and further the goals of the California Global Warming Solutions Act of 2006 (AB 32). The emphasis of the Forest Health Program is to increase the carbon stored in living trees and protect forests, fish and wildlife habitats, native plant species and water by creating forests consisting of optimally spaced trees that are resilient to wildfire and tree mortality. Applications are due January 29, 2019. The Office of Recovery and Resiliency is coordinating with applicable County Departments and partners to consider projects. For more information see:

http://www.fire.ca.gov/resource_mgt/resource_mgt_foresthealth_grants

K. Coordinate other Recovery-Related Grant and External Funding Opportunities

The Office of Recovery and Resiliency is tracking, investigating, and coordinating other grant opportunities for recovery-related priorities as well. When new opportunities are announced, Grant Summaries and targeted information is provided to County Departments and partners. A comprehensive list of recovery-related external funding opportunities is ongoing within the County Administrator's Office, and the status of actions taken is being tracked.

L. Crisis Counseling Assistance and Training Program Grant

The Crisis Counseling Assistance and Training Program, known locally as California HOPE, is administered in Sonoma County through the County Department of Health Services, Behavioral Health Division. **California HOPE counselors have helped to provide over 65,800 services and counseling sessions to community members (this data contains duplicate individuals). Services provided reached a peak in August 2018, of over 5,000 participants, with 3,000 participants served in September.**

The California HOPE program helps individuals and communities recover from natural and human-caused disasters through community outreach, counseling, and access to mental health services for survivors of these disasters. Counselors are available to meet people wherever they are to provide crisis counseling, resource navigation, and disaster recovery education. Counselors specialize in helping survivors understand their current reactions, reduce stress, receive emotional support, prioritize their needs and solve problems, choose coping strategies, and connect with people and agencies who can help. Bilingual counselors are available.

This program is funded from a variety of sources. The initial recovery work is supported by short-term disaster relief grants from FEMA for \$4.3M. The California HOPE funding from FEMA ends in January 2019, and Kaiser Permanente has confirmed an additional \$1M. Sonoma County Department of Health Services is pursuing additional funding to continue California HOPE up to September 2019.

3. Looking Forward

A. Recovery and Resiliency Draft Framework

Your Board received and discussed the Draft Framework on September 25, 2018, and opened a 30-day public comment period on the document that ended October 26. The Draft Framework is available online at <https://sonomacounty.ca.gov/ORR/>. Print copies are available at the County Administrator's Office at 575 Administration Drive, Suite 104A, Santa Rosa. Community members are encouraged to submit recovery related feedback, input, and questions to recoveryinfo@sonoma-county.org. Additional information is available on the Office of Recovery website at <https://sonomacounty.ca.gov/ORR/>. For information on overall recovery efforts, visit www.sonomacountyrecovers.org

Community engagement and outreach: The Office used community engagement to gain feedback and input to inform the Draft Framework, including holding seven Recovery Planning Community Meetings to obtain public feedback and input on the Framework. Two forums were conducted in Spanish. The meetings were attended by 306 members of the public. Since June, Recovery staff also has met with about 80 groups, businesses, nonprofits, stakeholders and outside agencies and governments to update them on County recovery efforts and receive input that has informed recovery planning.

Timeline: The Recovery and Resiliency Framework will be brought to your Board in December 2018 for approval.

Prior Board Actions:			
Regular Recovery updates have been provided to your Board since November 2017.			
Strategic Plan Alignment Not Applicable			
Fiscal Summary			
Expenditures	FY 18-19 Adopted	FY 19-20 Projected	FY 20-21 Projected
Budgeted Expenses			
Additional Appropriation Requested			
Total Expenditures			
Funding Sources			
General Fund/WA GF			
State/Federal			
Fees/Other			
Use of Fund Balance			
Contingencies			
Total Sources			
Narrative Explanation of Fiscal Impacts:			
Staffing Impacts			
Position Title (Payroll Classification)	Monthly Salary Range (A – I Step)	Additions (Number)	Deletions (Number)
Narrative Explanation of Staffing Impacts (If Required):			

Attachments:
Related Items "On File" with the Clerk of the Board:



County of Sonoma Agenda Item Summary Report

Clerk of the Board
575 Administration Drive
Santa Rosa, CA 95403

Agenda Item Number: 22
(This Section for use by Clerk of the Board Only.)

To: Sonoma County Board of Supervisors

Board Agenda Date: November 13, 2018

Vote Requirement: Majority

Department or Agency Name(s): Economic Development

Staff Name and Phone Number:

Al Lerma (707) 565-6428

Supervisorial District(s):

Title: Funding for Economic Development Board Tourism Reports and Research

Recommended Actions:

Approve and authorize the Chair of the Board to execute a Memorandum of Understanding (MOU) with the Sonoma County Tourism Bureau (SCTB), to provide \$51,000 in revenues for the Economic Development Board in exchange of various research and report services to the SCTB retroactively from July 1, 2018 through June 30, 2019 including any scheduled payments due as of those dates.

Executive Summary:

This item is for a Memorandum of Understanding between Sonoma County Tourism Bureau (SCTB) and Economic Development Board (EDB) to fund the EDB to provide research and report services related to Transient Occupancy Tax, tourism, and Sonoma County Restaurant Week.

Discussion:

In July 2005, the Sonoma County Tourism Bureau (SCTB) assumed the activities of the Economic Development Board's (EDB) tourism division. Although the County's program ceased its tourism operations, there is tourism-related research and data analysis that is important to the forecasting and future projections of the tourism industry, one of Sonoma County's strongest economic drivers. Congruent with the EDB's research program, the SCTB has requested that the EDB provide the following services during fiscal year 2018-2019:

1. Transient Occupancy Tax (TOT) & Industry Development Report – a quarterly and annual compilation of TOT revenues as reported by the cities and unincorporated areas of the County as a measure of progress, and the ongoing tracking of new lodging development projects as reported by local permitting agencies.
2. Annual Tourism Report – an annual compilation of surveys and statistical information distributed to the tourism industry.
3. Return on Investment Competition Updates and Research – return on investment studies to gauge effectiveness of SCTB programs and updates on identified competitors. The report may include details on competitors' budgets, personnel, and marketing/business developments.

4. Sonoma County Restaurant Week – Organize, run and report on Sonoma County Restaurant Week, including organizing the participation of restaurants, data collection materials, and local promotion and web presence.
5. Comprehensive Research and Opportunities Report – a synthesis of all existing research that pertains to Sonoma County’s tourism industry and recommendations for other tourism-related research.

The services outlined are performed internally by the current project intern. This MOU has been presented to the Board of Supervisors on an annual basis. If accepted, staff will return in a year to present the FY 2019-2020 Memorandum of Understanding with the Sonoma County Tourism Bureau.

Prior Board Actions:

The Board of Supervisors have annually adopted similar MOU agreements since FY07-08. The last MOU was adopted on August 22, 2017.

Strategic Plan Alignment Goal 2: Economic and Environmental Stewardship

The Economic Development Board works closely with the Sonoma County Tourism Bureau in order to promote tourism and growth in Sonoma County.

Fiscal Summary

Expenditures	FY 18-19 Adopted	FY 19-20 Projected	FY 20-21 Projected
Budgeted Expenses	\$51,000		
Additional Appropriation Requested			
Total Expenditures	51,000		
Funding Sources			
General Fund/WA GF			
State/Federal			
Fees/Other	51,000		
Use of Fund Balance			
Contingencies			
Total Sources	\$51,000		

Narrative Explanation of Fiscal Impacts:

Through this MOU, the SCTB will provide the EDB with \$51,000 in revenues for services, which will be used by the EDB to fully fund one extra-help full-time intern position.

Staffing Impacts			
Position Title (Payroll Classification)	Monthly Salary Range (A – I Step)	Additions (Number)	Deletions (Number)
Narrative Explanation of Staffing Impacts (If Required):			
Attachments:			
Att1_Copy of Memorandum of Understanding with Sonoma County Tourism Bureau.			
Related Items "On File" with the Clerk of the Board:			

MEMORANDUM OF UNDERSTANDING
BETWEEN THE
SONOMA COUNTY TOURISM BUREAU
AND THE COUNTY OF SONOMA

This Memorandum of Understanding (MOU) is entered into on the first day of July 2018 by and between the SONOMA COUNTY TOURISM BUREAU (“SCTB”) and the COUNTY OF SONOMA, acting through its ECONOMIC DEVELOPMENT BOARD (“EDB”).

AGREEMENT

The purpose of this Memorandum of Understanding is to establish and maintain an economic research program on the hospitality industry, to be executed by the EDB with the support of the SCTB. To further this purpose, the parties to this MOU agree as follows:

A. SERVICE AND PAYMENT TERMS

The EDB shall perform the following tasks:

1. Transient Occupancy Tax (TOT) and Industry Development Report

On a quarterly and annual basis, the EDB will (a) compile data on TOT performance, as reported by cities and the County, as a tool to measure the progress and impact of various tourism-related programs and (b) compile data on development of new lodging facilities by obtaining information from the local permitting authorities in both cities and the County.

The compilation of TOT performance data will be presented in an approximately five-page report, which will include:

- Historical and current TOT collections for each city and the County, by quarter.
- Year over year absolute and percent changes in TOT collections for each city and the County.
- The quarterly and annual “share” of total TOT collected by each city and the County.
- A chart showing how each municipality spends their TOT (e.g. General fund or general fund and specific programs by percentage).

This report will be similar in format and scope to previous TOT reports.

The compilation of data on development of new lodging facilities will be presented in an approximately two-page report, which will include, for each new lodging facility identified:

- The tentative name and address for the facility

- The number of proposed rooms
- The expected average daily room rate of the facility
- The expected annual TOT and BIA collections for the facility
- The estimated date of completion

The report will also strive to maintain current information on vacation rentals run by private owners (VRBO) as well as AirBnB-type short-term rentals.

2. Annual Tourism Report

The EDB will produce an Annual Tourism Report on the tourism industry in Sonoma County. The EDB will incorporate surveys and other information from Economy.com, the California Travel & Tourism Commission, US Travel Association, SCT research, and the annual tourism industry survey and other sources into the report. EDB anticipates that the Annual Tourism Report will be released in May 2019, but the report may be delayed if required to collect necessary data.

This report will include extensive written analysis on current and anticipated trends in the hospitality industry, including employment and output in local and nationwide industries; supply/demand factors; operating costs; upside and downside risk factors; two to four charts with commentary; impacts of VRBO and AirBnB dollars, reporting rate and overall presence; and five-year forecast detail for key U.S. macro drivers.

3. Research: ROI, Intercept, Competition Updates

The EDB will conduct periodic return-on-investment studies on SCTB programs to assist SCTB in gauging effectiveness and/or ROI of programs and to guide sales and marketing efforts. Examples of these studies include, but are not limited to, meeting planner survey, tour operator survey, advertising effectiveness surveys, economic impact surveys and others. SCTB will expect four (4) completed reports per year. EDB may consult with an outside researcher or travel economist for assistance.

The EDB will provide updates, when requested, on identified competitors. The details of the update may contain the competing DMO's budget, personnel, and recent notable marketing/business developments. The report can also include samples of advertising, marketing and other tourism-promotion efforts from these destinations. This is to be presented in a monthly research update to the SCT PR/Marketing team as a Monthly Research Update.

4. Sonoma County Restaurant Week

The EDB will organize, run and report on Sonoma County Restaurant Week (SCRW) in March 2019. This includes organizing participating restaurants, data collection materials and all local promotion and web presence. Following the event, the EDB is responsible for producing a report that outlines the economic impact, qualitative consumer feedback and restaurant perceptions of the event. The report will also include information about the events' web presence.

EDB will query restaurateurs via survey after the next SCRW scheduled for March 2019, to find the optimal time of year for SCRW, with consideration to be given for alignment with existing marketing efforts for statewide “California Restaurant Week” in January of 2019, based on the survey results.

5. Comprehensive Research and Research Opportunities Report

The EDB will maintain a report consisting of two main parts: 1) a synthesis of all existing research conducted pertaining to Sonoma County’s tourism industry, and 2) provide recommendations for other tourism-related research reports/surveys/studies. The EDB will make any updates to existing reports with new research, research potential research initiatives that have been conducted and proven worthwhile by other branches of tourism (e.g. U.S. Travel Association, San Francisco Travel, etc.) or suggest sections for update. The EDB will also identify the most frequently asked questions received by the SCTB and the EDB concerning the tourism industry.

As compensation for all services contemplated by this Agreement, SCTB shall pay COUNTY the sum of \$51,000.

The SCTB shall make four equal payments; the first payment of twelve thousand, seven hundred fifty dollars (\$12,750) will be paid to the COUNTY September 30, 2018, with the next three payments as follows: December 1, 2018, March 1, 2019 and June 15, 2019.

B. GENERAL PROVISIONS

1. Term of Agreement

- a. The term of this Agreement shall be from July 1, 2018 through June 30, 2019 unless terminated earlier in accordance with the provisions in 1.b.
- b. Either party to this Agreement may terminate the Agreement for convenience and without cause, by giving the other party 30 days advance written notice of the effective date of termination. In the event of termination, COUNTY shall be entitled to retain compensation for each completed month of service since July 1, at a rate of one-twelfth per month, through the date of termination.
- c. In order to better facilitate communication and to train EDB staff on the hospitality industry, EDB employees will work on site at the SCTB offices, or out in Sonoma County, at least one day per work week. Work will include attending meetings with SCTB staff as it pertains to projects, coordinating with SCTB on tasks as outlined above, and implementing research and education initiatives in the community. SCTB will provide a desk and computer for EDB staff to work on while working onsite.

2. Notices

All notices, bills, and payments shall be made in writing and shall be given by personal delivery or by U.S. Mail or courier service. Notices, bills, and payments shall be addressed as follows:

COUNTY: Sonoma County Economic Development Board
141 Stony Circle, Suite 110
Santa Rosa, CA 95401

SCTB: Sonoma County Tourism Bureau
400 Aviation Blvd., Suite 500
Santa Rosa, CA 95403

3. Assignment/Delegation

Neither party hereto shall assign, sublet or transfer any interest in this Agreement or any duty hereunder without written consent of the other, and no assignment shall be of any force or effect whatsoever unless and until the other party shall have so consented.

4. Merger

This writing is intended both as the final expression of the Agreement between parties hereto with respect to the included terms and as a complete and exclusive statement of the terms of the Agreement. No modification of this Agreement shall be effective unless and until such modification is evidenced by a writing signed by both parties.

IN WITNESS WHEREOF, the parties hereto have executed this Agreement as set forth below.

SONOMA COUNTY TOURISM BUREAU

DATED: _____

By: _____
Claudia Vecchio, CEO

COUNTY OF SONOMA

CERTIFICATES OF INSURANCE ON
FILE WITH AND APPROVED AS TO
SUBSTANCE BY DEPARTMENT:

DATED: _____

By: _____
Ben Stone, Economic Development Director

APPROVED AS TO FORM:

DATED: _____

By: _____
Linda Schiltgen, Deputy County Counsel

COUNTY OF SONOMA

DATED: _____

By: _____
Chair, Board of Supervisors

DATED: _____

ATTEST: _____
Clerk of the Board of Supervisors



County of Sonoma Agenda Item Summary Report

Clerk of the Board
575 Administration Drive
Santa Rosa, CA 95403

Agenda Item Number: 23
(This Section for use by Clerk of the Board Only.)

To: Board of Supervisors

Board Agenda Date: November 13, 2018

Vote Requirement: Majority

Department or Agency Name(s): Economic Development Board

Staff Name and Phone Number:

Ben Stone – (707) 565-7170

Supervisorial District(s):

Title: Sonoma County Economic Development Board Foundation Annual Report for FY17-18

Recommended Actions:

Receive the Sonoma County Economic Development Board Foundation's Annual Report for Fiscal Year ending June 30, 2018

Executive Summary:

This item is to present the Sonoma County Economic Development Board Foundation's Annual Report for Fiscal Year 2017-2018, in accordance with the MOU between the County and the Foundation, and with the Foundation's bylaws.

Discussion:

The Sonoma County Economic Development Board Foundation (Foundation) was developed and designed solely to support the Economic Development Board's mission and events, as approved by the Board of Supervisors. The Foundation began its first year of operations in Fiscal Year 2002-2003. In August 2002, it signed an Operational Memorandum of Understanding with the Sonoma County Board of Supervisors that formally defined the relationship between the Foundation and the Economic Development Board (EDB), an agency of the County of Sonoma. The Foundation has produced its annual report for the Board's review for the fiscal year ending June 30, 2018, as required by Article 8.1(f) of the First Amended and Restated Bylaws of the Foundation.

The Foundation continues to provide support to the local community, the County, and the business and philanthropic communities. The Foundation received \$845,553 in revenue, grants, and donations for Fiscal Year 2017-2018. This revenue was used to support more than 40 workshops, conferences and special events; and more than 40 quarterly and annual economic activity reports and forecasts. The Foundation continues to provide ways for local businesses to attend educational events and forums, and to actively engage in and gain a meaningful understanding of the Sonoma County economy.

In Fiscal Year 2017-2018, the Foundation supported four signature annual events, as well as funded several new events, workshops and initiatives. The following are a few highlights of the projects supported or funded by the Foundation:

- The Creative Sonoma program produced 22 professional trainings and workshops, grant making programs, and special initiatives focused on fire response and recovery. These activities were fully or partially funded through grants received by the EDB Foundation which funded program expenses as well as staff costs. Creative Sonoma disbursed \$164,000 to 129 creative individuals, organizations, and businesses (in quick grants of up to \$1,500 each) that were either physically or economically impacted by the 2017 wildfires; as well as \$36,000 to eight arts organizations that are producing events or creative works in response to the fires.
- The Foundation provided funding toward the consultant costs to produce **Strategic Sonoma**, a five-year strategic plan for the county's local economy. The plan addresses some of the region's most pressing issues and opportunities around workforce, economic resilience, innovation and entrepreneurship, and economic inclusion for all Sonoma County residents. The plan also includes a short-term 6-12 month recovery plan that was developed in the wake of the October 2017 fires and is in alignment with the Board of Supervisor's recovery plan.
- The Foundation provided funding for the first-ever **Manufacturing Day Sonoma County**, an event that seeks to inspire the next generation of Sonoma County manufacturers by supporting direct industry engagement with students, creating hands-on learning opportunities, and promoting education and training pathways that lead to careers in manufacturing.
- The Foundation provided funding for the inaugural **Outdoor Recreation & Biking Summit**, that brought together industry leaders and government officials, during which a select and diverse panel of influential outdoor recreation businesses communicated insightful stories to the audience of launching and growing their businesses in Sonoma County, and thoughts for growing this economic cluster in the future

Economic Forecast Events

- Dr. Steve Cochrane of Moody's Economy.com spoke at the *Spring Economic Forecast* to a breakfast group of over 400 local business owners, investors, community leaders and public. The coalescing theme of the event was Strategic Sonoma's newly completed five-year strategic plan for our local economy. The plan addresses some of our region's most pressing problems around workforce, economic resilience, innovation and entrepreneurship, and economic inclusion for all Sonoma County residents. It also includes a short-term 6-12 month recovery plan that was developed in the wake of the October 2017 fires as part of the Board of Supervisor's recovery plan. The event also featured Avalanche CEO Amy Hollowell, who presented the highlights of the Strategic Sonoma Action Plan as well as various pop-up speakers who addressed key elements of the plan.
- The *Fall Economic Forecast* with Dr. Christopher Thornberg is an annual event of the Foundation's Research Initiatives Program developed for local businesses, governments, and organizations for

detailed regional analysis of economic trends. Dr. Thornberg presented an informative and upbeat talk about California and Sonoma County, including GDP growth, oil production and prices, foreign trade, global growth, industrial production, consumer spending, labor market, local economic performance, tourism, wine industry, real estate, construction, and more. He also included a segment addressing the impact of last year's fires on our local economy. The total number of attendees at the event was approximately 490 people.

- The *State of the County* is an annual event sponsored by the Economic Development Board (EDB) to present the current and future challenges facing the county in terms of growth and development, especially post-2017 wildfires. It is an opportunity for the County of Sonoma to showcase community leaders as they addressed the recovery efforts, what to expect in 2018, and to get community input at post-event breakout workshops. Attendance included nearly 500 people at this 15th annual breakfast.

In FY 2018-2019, the Foundation will continue to support its annual events as well as fund new projects and efforts of the EDB which include:

- Continue to support the County's recovery efforts by assisting businesses impacted directly or indirectly by the fires, and increasing efforts to attract new businesses to the county that may be unsure of the business climate after the wildfires.
- Providing funds toward the implementation of Strategic Sonoma's key projects, via the Morgan Foundation grant received for that purpose.
- Continue expanding our Access to Capital and Technical Assistance Project targeting low-to-moderate income business borrowers by seeking out additional revolving loan fund grants.
- Continue Creative Sonoma's post wildfires recovery efforts and their work on the assessment of the state of arts education in Sonoma County and the findings of the assessment.

Publishing our annual series of research reports on industry clusters and economic indicators, including workforce and economic data and providing customized reports.

Prior Board Actions:

The Sonoma County Economic Development Board Foundation submits this report to the Board for approval annually. The Foundation submitted the FY 2016-2017 report to the Board on December 12, 2017.

Strategic Plan Alignment Goal 2: Economic and Environmental Stewardship

Fiscal Summary			
Expenditures	FY 18-19 Adopted	FY 19-20 Projected	FY 20-21 Projected
Budgeted Expenses			
Additional Appropriation Requested			
Total Expenditures			
Funding Sources			
General Fund/WA GF			
State/Federal			
Fees/Other			
Use of Fund Balance			
Contingencies			
Total Sources			
Narrative Explanation of Fiscal Impacts:			
There are no costs associated with this report. The attached report provides a summary of FY 17-18 activities. During FY 17-18 the Foundation took in \$845,553 in revenue and recorded \$576,046 in expenses.			
Staffing Impacts			
Position Title (Payroll Classification)	Monthly Salary Range (A – I Step)	Additions (Number)	Deletions (Number)
Narrative Explanation of Staffing Impacts (If Required):			
Attachments:			
FY 2017-2018 Annual Report for the Sonoma County Economic Development Board Foundation			
Related Items “On File” with the Clerk of the Board:			

SONOMA COUNTY ECONOMIC DEVELOPMENT BOARD

FOUNDATION

Annual Report

July 1, 2017 – June 30, 2018

FOUNDATION

Annual Report

July 1, 2017 – June 30, 2018
Submitted September 26, 2018

Table of Contents

❖ From the Chair	3
❖ Executive Summary	4
❖ Introduction/Mission & History of the Foundation	6
❖ Financial Summary	
○ Statement of Financial Position	8
○ Statement of Activity	9
❖ Underwriters	10
❖ Project Summaries	
○ Spirit of Sonoma County	13
○ Special Events	15
❖ Board of Directors and Staff	17
❖ Attachment A: Certification of Financial Statements	18

FOUNDATION

September 26, 2018

Dear Colleagues:

We are pleased to present this annual summary of activities of the Sonoma County Economic Development Board Foundation (Foundation) for the year ending June 30, 2018. The Foundation's leadership continues to support the Economic Development Board (EDB) to ensure that the Foundation's efforts align with the mission and priorities of the EDB.

As we present the achievements of the projects held in fiscal year 2017-2018, the Board of Directors would like to thank our numerous sponsors and the County of Sonoma for their increasingly important efforts to improve the economic wellbeing of Sonoma County.



Pamela Chanter
Chair of the Board of Directors



Ben Stone
Executive Director

Executive Summary

The Sonoma County Economic Development Board Foundation (Foundation) continues to make strong connections between community needs, county projects, and support from the business and philanthropic communities. The Foundation received and effectively managed \$829,800 in event revenue, donations and grants, supporting more than forty (40) workshops, conferences and special events; more than forty (40) quarterly and annual economic activity reports and forecasts; and more than fifteen (15) customized reports. Through events and sponsorship opportunities, the Foundation provides an excellent way for local businesses to showcase their services and network with other community leaders.

Highlights of 2017-2018 Foundation Projects

- The **Creative Sonoma** program produced a full slate of professional trainings and workshops (22), grant making programs, and special initiatives focused on fire response and recovery. These activities were fully or partially covered through grants and fire recovery donations received by the EDB Foundation, which funded program expenses as well as staff costs. Professional development topics focused generally on the business aspects of art and included workshops on financial management for artists, selling creative work and products, managing nonprofit organizations, and more. Five \$2,500 grants were awarded to Sonoma musicians and bands to further their music careers. In fire response grant making, Creative Sonoma disbursed \$164,000 to 129 creative individuals, organizations, and businesses (in quick grants of up to \$1,500 each) that were either physically or economically impacted by the 2017 wildfires; as well as \$36,000 to eight arts organizations that are producing events or creative works in response to the fires. In addition, a cohort of teaching artists received specialized training to address trauma of school-aged populations, and Creative Sonoma is funding free residencies with these artists to fire-impacted schools throughout the County. Finally, Creative Sonoma continued work on an assessment of the state of arts education in K-12 schools in Sonoma County, which will carry on into 2018-2019.
- The Foundation provided funding to defray consultant costs to produce **Strategic Sonoma**, a five-year strategic plan for the county's local economy. The plan addresses some of the region's most pressing issues and opportunities around workforce, economic resilience, innovation and entrepreneurship, and economic inclusion for all Sonoma County residents. The plan also includes a short-term 6-12 month recovery plan that was developed in the wake of the October 2017 fires as part of the Board of Supervisor's recovery plan.

- The Foundation also provided funding for: the first-ever **Manufacturing Day Sonoma County**, an event that seeks to inspire the next generation of Sonoma County manufacturers by supporting direct industry engagement with students, creating hands-on learning opportunities, and promoting education and training pathways that lead to careers in manufacturing; the inaugural **Outdoor Recreation & Biking Summit**, that brought together industry leaders and government officials, and during which a select and diverse panel of influential outdoor recreation businesses communicated insightful stories to the audience of launching and growing their businesses in Sonoma County, and thoughts for the future; and the first **Retail Summit**, where a retail expert shared insights and strategies on how to compete with national and online retailers as part of Sonoma County's first-ever Retail Success Workshop. Small business owners, retail support service providers and representatives from local governments attended this pilot event and were engaged in a discussion regarding the unique challenges and opportunities small retailers face in Sonoma County.

Along with the year-end financial statements, the following pages summarize some of the Foundation's activities, detailed by program. While many of the projects will seek funding through the Foundation again in fiscal year 2018-2019, each year the Foundation Board evaluates the programs to ensure financial stability for the Foundation and the EDB.

Introduction

About the Foundation

The Foundation is a supporting organization that provides an alternative funding stream to EDB programs, relieving the burden on the limited funds of local government and strengthening community projects by managing funds from donors and foundations.

Mission

The Sonoma County Economic Development Board Foundation is a 501(c)(3) that through the creation, development and dissemination of economic research, analysis or programs enhances the value of local, domestic, and international demand for Sonoma County-produced goods and services.

History of the Foundation

On January 23, 2001, the Sonoma County Board of Supervisors approved the establishment of the Foundation to serve as a supporting organization to the EDB to expand funding sources available for EDB projects. In March 2001, the Foundation was incorporated as a California nonprofit public benefit corporation. During 2001, the Foundation Board of Directors elected officers and began formalizing procedures while awaiting review of its application for tax-exempt status. In February 2002, the Internal Revenue Service notified the Foundation of its approval of tax-exempt status under Section 501(c)(3) of the Internal Revenue Code.

In August 2002, the Foundation signed an Operational Memorandum of Understanding with the Sonoma County Board of Supervisors to formally define the relationship between the Foundation and the EDB, an agency of the County of Sonoma. Under that agreement, the Board of Supervisors oversees the Foundation's funding of EDB projects. In late August 2002, the Foundation began accepting funds and reviewing EDB projects in need of support.

In fiscal year 2002-2003, the Foundation's first year of operation, a great deal of care was taken to establish procedures that would guarantee steady and increasing support for EDB projects into the future. The Foundation continues to operate under the Operating Memorandum of Understanding and continues its efforts to create alternative revenue streams for EDB projects.

In September 2008, the Board of Supervisors approved the third Memorandum of Understanding which now contains a clause for automatic renewal annually.

Financial Summary

This section contains information about the Foundation's finances.

Statement of Financial Position
As of June 30, 2018
(Unaudited)

	June 30, 2018
ASSETS	
Current Assets	
Cash and cash equivalents	\$ 885,481
Short-term investments	73,796
Accounts receivable	14,340
Prepaid expenses	7,308
	980,925
Total Current Assets	980,925
TOTAL ASSETS	\$ 980,925
LIABILITIES AND NET ASSETS	
Current Liabilities	
Accounts payable	\$ 44
Deferred Grants Awarded	14,250
Deferred sponsorships	60,700
	74,994
Total Liabilities	74,994
Net Assets	
Unrestricted	-
Designated	445,827
Temporarily restricted	396,447
	842,274
Total Net Assets	842,274
Total Liabilities & Net Assets	\$ 917,268

Statement of Activity
For the year ended June 30, 2018
(Unaudited)

	Jul '17 - Jun '18		
	Unrestricted	Temporarily Restricted	Total
Revenues, gains and other support			
Registration/participation fees	\$ 121,352	\$ -	\$ 121,352
Donations/Sponsorships	115,416	217,623	333,039
Grants		375,410	375,410
Other income	14,389		14,389
Interest income	1,364		1,364
Total Income	<u>252,520</u>	<u>593,033</u>	<u>845,553</u>
Expenses			
Program services			
Community outreach	47,969	388,738	436,708
Economic outlook	59,057	-	59,057
Research initiatives	55,634	-	55,634
Supporting services			
Administrative Services	<u>24,647</u>	<u>-</u>	<u>24,647</u>
Total Expenses	<u>187,308</u>	<u>388,738</u>	<u>576,046</u>
Change in Net Assets	65,213	204,295	269,507
Net Assets, Beginning of Year	<u>380,614</u>	<u>192,152</u>	<u>572,766</u>
Net Assets, End of Year	<u>\$ 445,827</u>	<u>\$ 396,447</u>	<u>\$ 842,274</u>

Underwriters

This section provides a list of the business, education and community organizations that provided noteworthy contributions to the Foundation.

Foundation Underwriters

Foundation Level:

Luther Burbank Savings

Presenting Level:

City of Santa Rosa
Exchange Bank
Kaiser Permanente
Pacific Gas & Electric
Pure Luxury Transportation
Redwood Credit Union
Sonoma Raceway
Tri Counties Bank

Premier Level:

Bank of Marin
Employment Training Panel
Friedemann Goldberg LLP
Sonoma Clean Power
St. Joseph Health

Executive Level:

American River Bank
Comcast
Keegan & Coppin Co.
Midstate Constructions
NorBAR
Sonoma County Alliance
Summit State Bank
Vantreo Insurance Brokerage
Wells Fargo Bank
Zainer Rinehart Clarke

Media Level:

North Bay Business Journal

Project Summaries

This section provides information on some of the projects funded through the Foundation.

Together, the projects served many segments of Sonoma County, including public schools, public agencies, employers, and the business community and residents with an interest in the state of the County's economy.

Project Summary

Spirit of Sonoma County

Description

The annual *Spirit of Sonoma County* awards luncheon recognizes business leaders from major chambers and trade associations in the County. The awards ceremony attracted more than 350 people, honoring those awardees from 22 chambers and trade organizations chosen for their contributions to Sonoma County.

Program Goals

The *Spirit* awards honor those who contribute to the economic development and enhancement of the communities in which they live, work, and conduct business through generous donations of their time and expertise in support of local business and in helping others.

Achievements

In 2017-2018, the program celebrated its seventeenth anniversary, having honored more than 348 local business men and women and community leaders since its inception. The *Spirit of Sonoma County* awards program was started in 2001 with the assistance of banks, media, and elected officials in order to honor the selected award winners. The program grew from 18 area chambers and trade organizations recognizing a business leader from their group to the present 22 organizations involved. The *Spirit* luncheon is an excellent opportunity for local business leaders to receive countywide recognition.

Supporters

The *Spirit of Sonoma County* luncheon, ceremony, and awards are funded through registration fees paid by the participating organizations, corporate sponsors, and individuals who attend and/or sponsor tables. The 2017-18 local organizations that chose to purchase tables in support of honorees included:

Clean River Alliance
Exchange Bank
Family Justice Center
North Bay Leadership Council
Pedroncelli Winery
Poppy Bank
Pure Luxury Transportation
Rotary Club of Petaluma
Sonoma County Tourism Bureau

Awards

The *Spirit of Sonoma County* awards recognized honorees from these 22 organizations:

Cloverdale Chamber of Commerce
Geyserville Chamber of Commerce
Healdsburg Chamber of Commerce
Hispanic Chamber of Commerce
Mark West Area Chamber of Commerce
North Bay Leadership Council
North Coast Builders Exchange
Northern California Engineering Contractors Association
Petaluma Area Chamber of Commerce
Rohnert Park Chamber of Commerce
Russian River Chamber of Commerce
Santa Rosa Metro Chamber of Commerce
Sebastopol Area Chamber of Commerce
Sonoma County Alliance
Sonoma County Farm Bureau
Sonoma County Lodging Association
Sonoma County Winegrape Commission
Sonoma County Workforce Investment Board
Sonoma Valley Chamber of Commerce
Windsor Chamber of Commerce

Project Summary

Special Events

Featuring Keynote Speakers

Description

In 2017-2018 the Foundation supported three special events featuring professional keynote speakers contributing to a variety of subjects. The speakers are selected keeping current affairs and issues in mind.

Program Goals

This speaker events series is intended to provide the business community with interesting speakers addressing matters related to the local economy, industry trends and common business interests.

Achievements

The *Fall Economic Forecast* is an annual event of the Foundation's Research Initiatives Program developed for local businesses, governments, and organizations for detailed regional analysis of economic trends. As part of the Research Initiatives Program benefits, sponsors are invited to the dinner held with the featured speaker, Dr. Christopher Thornberg, the night preceding his presentation. Dr. Thornberg presented an informative and upbeat talk about California and Sonoma County, including GDP growth, oil production and prices, foreign trade, global growth, industrial production, consumer spending, labor market, local economic performance, tourism, wine industry, real estate, construction, and more. He also included a segment addressing the impact of this year's fires on our local economy. The total number of attendees at the event was about 490 people. The pre-event dinner was held at Ca'Bianca Restaurant, and the event was held at the Hyatt Hotel in Santa Rosa.

The *State of the County* is an annual event sponsored by the Economic Development Board (EDB) to present the current and future challenges facing the county in terms of growth and development, especially post-2017 wildfires. It was an opportunity for the County of Sonoma to showcase community leaders as they addressed the recovery efforts, what to expect in 2018, and get community input at post-event breakout workshops. Attendance included about 500 people at this 15th annual breakfast. The event was recorded and made available on the EDB website.

Dr. Steve Cochrane of Moody's Analytics spoke at the *Spring Economic Forecast* to a breakfast group of over 400 people. Well attended by various financial, construction, education and tourism-related businesses, the coalescing theme of the event at this time was Strategic Sonoma's newly completed five-year strategic plan for our local economy. The plan addresses some of our region's most pressing problems around workforce, economic resilience, innovation and

entrepreneurship, and economic inclusion for all Sonoma County residents. It also includes a short-term 6-12 month recovery plan that was developed in the wake of the October 2017 fires as part of the Board of Supervisor's recovery plan. The event included pop-up presentations moderated by Keith Woods, Chief Executive Officer of the North Bay Builders Exchange. The pop-ups focused on highlighting three key initiatives of Strategic Sonoma that are in action: 1)&2) Recover from the October 2017 fires and Build Necessary Housing with David Guhin of City of Santa Rosa speaking of the City's new housing rebuild portal and rebuild successes, and Larry Florin of Burbank Housing speaking to the affordable housing rebuild successes. And 3) Educate and Support our Workforce: Kathy Goodacre spoke of the CTE Foundation grant from Tipping Point that emphasizes the importance of building construction workforce and Oscar Chavez spoke of the WIB grant for helping to train construction workers and how it will work in concert with other programs. The event also had an introduction provided by Supervisor James Gore and Ben Stone from the EDB. The Sonoma County Office of Education (SCOE), Santa Rosa Junior College (SRJC) and Sonoma State University (SSU) had exhibits of Career Technical Education (CTE) programs they each offer students. A "tiny house" constructed by students of Healdsburg High School was also on display.

Supporters

Each of these events was supported by direct Foundation sponsors, and by individual attendees and tables sponsored by local organizations and businesses.

Board of Directors

FOUNDATION BOARD MEMBERS

Officers: Pam Chanter, President/Chair
Linda Kachiu, Treasurer
Ben Stone, Executive Director

Members: Jorge Alcazar
Skip Brand
Terri Dente
Terry Garrett
Kathryn Hecht
Wayne Leach
Michael Nicholls
Michael Tomasini

LEGAL SERVICES

The Foundation contracts with the Friedemann Goldberg LLP law firm to advise the Board of Directors on general legal matters, including state and federal law, relating to nonprofit tax-exempt organizations.

FINANCIAL SERVICES

The Foundation retained the services of Ms. Victoria Mwangi, Certified Public Accountant (CPA). The CPA assists with the Foundation's bookkeeping and prepares its tax documentation.

Attachment A

Certification of Financial Statements

The undersigned does hereby certify that:

1. She has been duly elected and qualified as, and at this date is, the Chair of the Board of Directors of the Sonoma County Economic Development Board Foundation (the "Foundation");
2. The financial statements contained in the Foundation's Annual Report, covering the period from July 1, 2017 to June 30, 2018, were prepared without audit from the books and records of the Foundation.

Pamela Chanter

Signed: _____ Date: Sept. 26, 2018

Pamela Chanter
Chair of the Board of Directors
Sonoma County Economic Development Board Foundation



County of Sonoma Agenda Item Summary Report

Agenda Item Number: 24
(This Section for use by Clerk of the Board Only.)

Clerk of the Board
575 Administration Drive
Santa Rosa, CA 95403

Board of Supervisors, County of Sonoma

November 13, 2018

Majority

Fire and Emergency Services

Jim Colangelo / 565-1154

First, Third, Fourth and Fifth Districts

Concurrent Resolution Supporting the Application to the Local Agency Formation Commission for the Reorganization of the Windsor Fire Protection District

Approve a Concurrent Resolution of the Board of Directors of the Windsor Fire Protection District, Rincon Valley Fire Protection District, Bennett Valley Fire Protection District and Sonoma County Board of Supervisors supporting the Reorganization of the Windsor Fire Protection District.

The Local Agency Formation Commission (LAFCO) recently approved a Sphere of Influence amendment to the Windsor Fire Protection District (WFPD) to include the Rincon Valley Fire Protection District (RVFPD), Bennett Valley Fire Protection District (BVFPD) and the portion of County Service Area No. 40 (CSA 40) that is served by the Mountain Volunteer Fire Department (MVFD).

The WFPD is now initiating an application with LAFCO to annex the territories in the RVFPD, BVFPD and a portion of CSA 40. By adopting this concurrent resolution, the Board will be stating their support for the annexation and streamlining the LAFCO process.

The Board of Supervisors has previously provided direction to staff to seek out fire agencies that could assume the responsibility to provide support services to the eleven volunteer fire companies in CSA 40. Through this proposed action, the WFPD would assume all responsibility for fire response in this area that has been served by the MVFD.

In addition, the County's Fire Services Project has identified consolidation of fire agencies in the County as an important step towards achieving the goal of a more effective, efficient and sustainable fire service in the County.

Following the filing of an application with LAFCO, the amount of property tax generated in the areas will be identified and a Property Tax Transfer Resolution will be presented to the Board for their consideration. At that time, the WFPD may be requesting funding to implement portions of the Fire Services Deployment Plan that was adopted by the Board on 8/14/18.

SUMMARY

This Resolution states the Board’s support for filing an application with LAFCO and commencing the process to determine the fiscal impacts of the proposed Reorganization. Adopting the Concurrent Resolution will streamline the LAFCO application process for all affected agencies. The Board will still have discretion to consider the fiscal impacts of the proposed action and take appropriate action at a later date.

Prior Board Actions:

08/14/2018: Approved the Fire Services Deployment Plan and the Priority Steps

06/11/2018: Received an Update on the Fire Services Project

07/19/2016: Approved allocating a percentage of Transient Occupancy sales tax funds towards fire services.

04/19/2016: Adopt a resolution creating the Fire Services Advisory Council and appointing its initial members.

12/09/2015: Receive the interim report on the Fire Services Project and give direction on recommendations of the Advisory Committee

Strategic Plan Alignment Goal 1: Safe, Healthy, and Caring Community

Fire and emergency services are critical to the safety, health, and well-being of Sonoma County’s residents and visitors.

Fiscal Summary

	FY 18-19 Adopted	FY 19-20 Projected	FY 20-21 Projected
Expenditures			
Budgeted Expenses	-0-		
Additional Appropriation Requested	-0-		
Total Expenditures	-0-		
Funding Sources			
General Fund/WA GF	-0-		
State/Federal	-0-		
Fees/Other	-0-		
Use of Fund Balance	-0-		
Contingencies	-0-		
Total Sources	-0-		

Narrative Explanation of Fiscal Impacts:

A property tax transfer agreement will be brought to the Board at a later date when the fiscal impacts of the proposed Reorganization have been fully identified.

Staffing Impacts			
Position Title (Payroll Classification)	Monthly Salary Range (A – I Step)	Additions (Number)	Deletions (Number)
Narrative Explanation of Staffing Impacts (If Required):			
None.			
Attachments:			
Resolution (A1); Subject Agency Map (A2)			
Related Items “On File” with the Clerk of the Board:			
None.			

S:\BOS AGENDA\Fire\Fire Services Project\11-13-2018 FES Windsor FPD Reorg\11-13-2018 FES Windsor FPD Reorg_Summ.docx

RESOLUTION No. 495**Dated: October 16, 2018****A CONCURRENT RESOLUTION OF THE BOARD OF DIRECTORS OF THE WINDSOR FIRE PROTECTION DISTRICT, THE BOARD OF DIRECTORS OF THE RINCON VALLEY FIRE PROTECTION DISTRICT, THE BOARD OF DIRECTORS OF THE BENNETT VALLEY FIRE PROTECTION DISTRICT, AND THE BOARD OF SUPERVISORS OF THE COUNTY OF SONOMA; CONSTITUTING THE DISTRICTS' RESOLUTION OF APPLICATION TO THE LOCAL AGENCY FORMATION COMMISSION OF SONOMA COUNTY FOR THE REORGANIZATION OF THE WINDSOR FIRE PROTECTION DISTRICT**

WHEREAS, the Boards of Directors of Windsor Fire Protection District (“WFPD”), Rincon Valley Fire Protection District (“RVFPD”, Bennett Valley Fire Protection District (“BVFPD”), and the Board of Supervisors of the County of Sonoma on behalf of the Mountain Volunteer Fire Company in County Service Area No. 40 (“Mountain VFC”), all located in Sonoma County, California (“the Parties”), desire to initiate proceedings pursuant to the Cortese-Knox-Hertzberg Local Government Reorganization Act of 2000, commencing with section 56000 of the California Government Code (“Cortese-Knox-Hertzberg Act”), with the Local Agency Formation Commission of the County of Sonoma (“Sonoma LAFCO”) for the reorganization of the Parties as specified herein; and

WHEREAS, the Parties have agreed to initiate proceedings with Sonoma LAFCO by adoption of this Concurrent Resolution for reorganization consisting of the dissolution of RVFPD and BVFPD, and detachment of Mountain VFC from County Service Area No. 40; and annexation of the territory in the dissolved Districts and detached area to the WFPD (“the Proposed Reorganization”) resulting in a reorganized fire protection district (“the Reorganized District”); and

WHEREAS, California Government Code section 56853 provides in part that, in the case of a concurrent resolution for reorganization, Sonoma LAFCO shall approve or conditionally approve, the Proposed Reorganization; and

WHEREAS, the boundaries of the territory included in the Reorganized District will be the combined territories of WFPD; RVFPD; BVFPD, and Mountain VFC, as described in Exhibit “A”, attached hereto and incorporated herein by this reference; and

WHEREAS, the territory included in the Reorganized District is inhabited, as defined in the Cortese-Knox- Hertzberg Act; and

WHEREAS, the Proposed Reorganization is consistent with the amended spheres of influence of the Parties, based on specific determinations in Sonoma LAFCO Resolution No. 2692, adopted on September 5, 2018; and

WHEREAS, the Parties desire that the Proposed Reorganization be subject to the following terms and conditions as set forth herein:

- a. The name of the Reorganized District shall be the "Sonoma County Fire District".
- b. The Reorganized District is intended to achieve greater economy and efficiency in providing fire protection and emergency services. The Parties have determined that the Proposed Reorganization is in the best interest of the Parties in order to protect better services to the residents of the Reorganized District.
- c. Pursuant to the provisions of California Health and Safety Code §13842 and Government Code section 56886(n), the Reorganized District shall be governed by a seven (7) member Board of Directors. The initial Board of Directors of the Reorganized District shall be composed of three (3) of the existing (5) directors of the WFPD; three (3) of the existing five (5) directors of the RVFPD; and one (1) of the existing five (5) directors of the BVFPD. The initial Board of Directors shall meet as soon as practicable after the effective date of the Proposed Reorganization and shall classify themselves by lot into two classes, one class consisting of four (4) directors and one class consisting three (3) directors. The term of office of the class having the greater number of directors shall be through December 2020, and subject to election in November 2020; and the term of the office of the class having the lesser number of directors shall be through December 2022, and subject to election in November 2022. Except for the initial Board of Directors, the term of office of directors shall be four years, and directors shall be elected or appointed as provided by law.
- d. All assets, unrestricted, restricted or fiduciary, held by the Parties shall be transferred to and become assets of the Reorganized District. The Reorganized District shall be the successor agency to the Parties.
- e. The Parties shall enter into a property tax allocation agreement to transfer the dissolving Districts' and Mountain VFC property tax allocation to WFPD for funding of the Reorganized District.
- f. The Parties request a determination by Sonoma LAFCO that the initial appropriation limit for the Reorganized District shall be the total of the combined existing appropriation limits of WFPD, RVFPD, BVFPD and Mountain VFC, as well as the anticipated

increased tax collections projected from the extension of the WFPD's special taxes throughout the Reorganized District.

- g. All liabilities of the Parties shall be transferred to and become liabilities of the Reorganized District.
- h. The effective date of the Proposed Reorganization shall be the date of recordation of the certificate of completion of reorganization as provided by Government Code section 57200 et seq.
- i. Distribution of Services: The Board of Directors of the Reorganized District will authorize an annual work plan for services throughout the Reorganized District.

WHEREAS, the Parties hereby consent to the Proposed Reorganization without election by the registered voters within the respective Districts and Mountain VFC; and

WHEREAS, the Parties' find that the Proposed Reorganization appears to be categorically exempt on the California Environmental Quality Act ("CEQA") by virtue of section 15320 of the State CEQA Guidelines ("Class 20 Exemption") because the Proposed Reorganization is a reorganization of a local government agencies where the changes do not change the geographical area in which previously existing powers are exercised.

NOW, THEREFORE, the Boards of Directors of Windsor Fire Protection District, the Rincon Valley Fire Protection District, and the Bennett Valley Fire Protection District, and the Board of Supervisors exercising jurisdiction over and on behalf of Mountain VFC, hereby find, determine, declare, resolve and order as follows:

1. The foregoing recitals are true and correct and are adopted as herein for above-set forth.
2. Sonoma LAFCO is requested to undertake proceedings for the Proposed Reorganization according to the terms and conditions stated above and in the manner provided in the Cortese-Knox- Hertzberg Act.
3. The President of the Board of Directors of each Party is authorized and directed to execute this Concurrent Resolution and any other documents as Sonoma LAFCO may reasonably request to accomplish the Proposed Reorganization initiated by this Concurrent Resolution.

This Concurrent Resolution is effective from the latest date of execution shown below.

WINDSOR FIRE PROTECTION DISTRICT:

Passed, approved and adopted at a regular meeting of the Board of Directors of the Windsor Fire Protection District by the following votes. Passed and adopted this 16th day of Oct 2018.



President, Board of Directors

Ayes: 4

Noes: 1

Absent: 0

CERTIFICATION:

Clerk of the Board of Directors

RINCON VALLEY FIRE PROTECTION DISTRICT:

Passed, approved and adopted at a regular meeting of the Board of Directors of the Rincon Valley Fire Protection District by the following votes. Passed and adopted this 16th day of Oct 2018.

President, Board of Directors

Ayes: 3

Noes: 2

Absent: 0

CERTIFICATION:

Clerk of the Board of Directors

BENNETT VALLEY FIRE PROTECTION DISTRICT:

Passed, approved and adopted at a regular meeting of the Board of Directors of the Bennett Valley Fire Protection District by the following votes. Passed and adopted this October 23, 2018.



President, Board of Directors

Ayes: 4

Noes: 0

Absent: 1

CERTIFICATION:

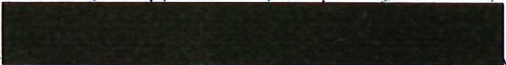

Clerk of the Board of Directors

COUNTY OF SONOMA on behalf of the Mountain Volunteer Fire Company in County Service Area No. 40:

Supervisors:

Gorin:	Rabbitt:	Zane:	Hopkins:	Gore:
Ayes:	Noes:	Absent:	Abstain:	

So Ordered.

ATTEST:

Clerk of the Board of Supervisors Date

Figure 1: Map of Region Including Subject Agency Boundaries

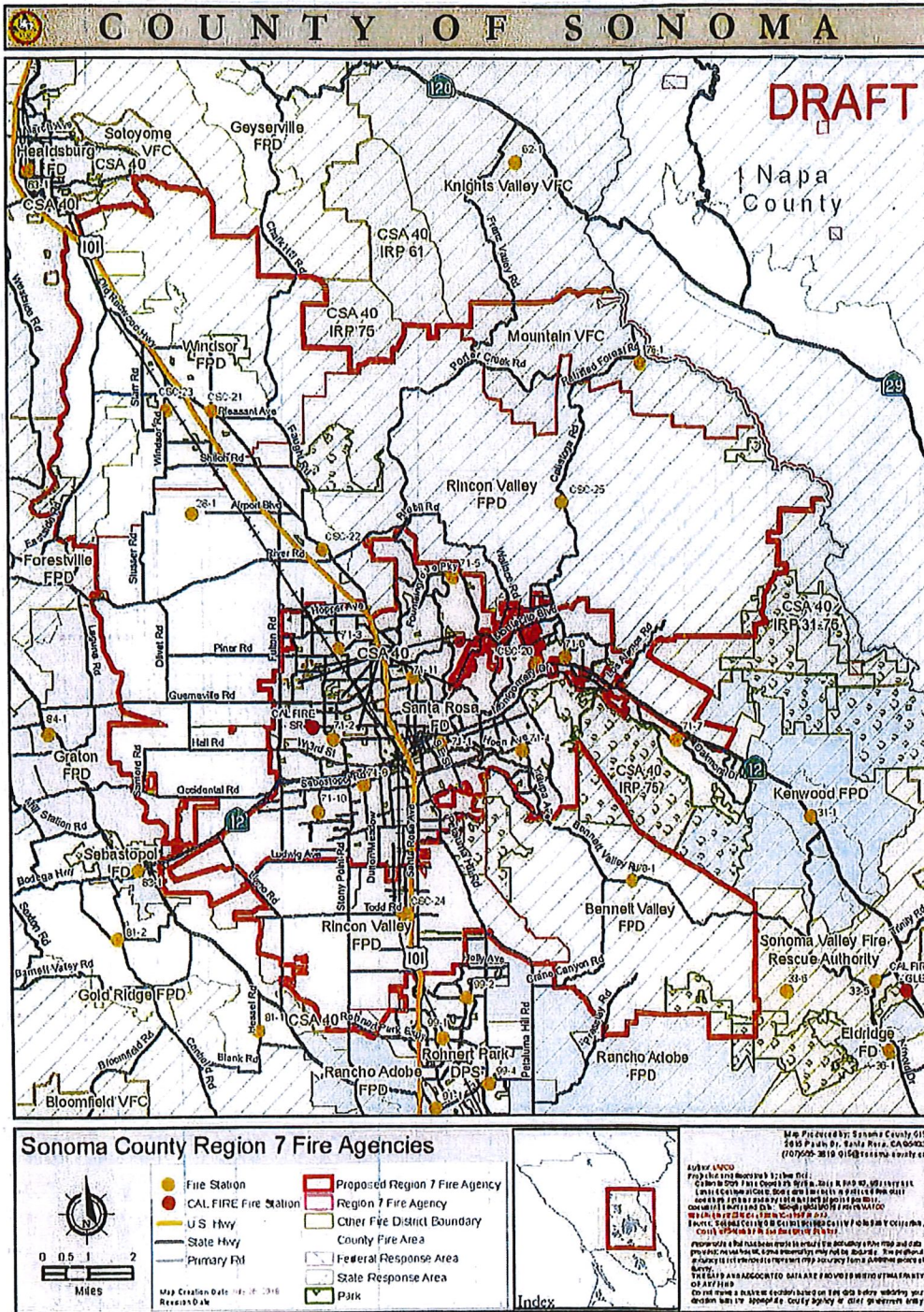



County of Sonoma Agenda Item Summary Report

Clerk of the Board
575 Administration Drive
Santa Rosa, CA 95403

Agenda Item Number: 25
(This Section for use by Clerk of the Board Only.)

To: Sonoma County Board of Supervisors

Board Agenda Date: November 13, 2018

Vote Requirement: Majority

Department or Agency Name(s): General Services / Health Services

Staff Name and Phone Number:

Caroline Judy, General Services: 565-8038
Barbie Robinson, Health Services: 565-7876

Supervisorial District(s):

Title: Lease extensions (2) for office space for Department of Health Services at 16390 Main Street, Guerneville

Recommended Actions:

Consider multiple actions ensuring continued public access to health services in west county:

1) Authorize the Clerk of the Board to publish a notice, declaring the Board's intent to enter into lease amendments (2) with Kirk Veale d/b/a Veale Investment Properties to:

a. Extend the term of a lease for 1,918 sq. ft. of office space (Suites B and G) located at 16390 Main Street, Guerneville, through October 31, 2023 and to specify the monthly rent payments;

b. Extend the term of a lease for 583 sf. ft. of office space (Suites F, H, I and J) at 16390 Main Street, Guerneville through November 30, 2023, and to specify the monthly rent payments; and

2) Authorize the General Services Director, in consultation with and using forms approved by the County Counsel, to execute future lease amendments, extension options, and associated documents required for County use of the premises under the leases, and which are consistent with the material terms of the leases and which, other than the extension options contained therein, do not extend the term of the leases.

Executive Summary:

Since November 2006, the Department of Health Services ("Health Services") has been providing health services to west Sonoma County clients at offices located in the former Bank of America building at 16390 Main Street in Guerneville ("Building"), through leases executed with Kirk Veale d/b/a Veale Investment Properties ("Landlord").

Program staff for the Women, Infants, and Children program and the Driving Under the Influence program occupy office space (583 sq. ft.) in Suites F, H, I and J of the Building subject to a lease with a term that expires on November 30, 2018. The Community Mental Health Center staff occupies office space (1,918 sq. ft.) in Suites B and G of the Building subject to a lease with a term expiration date of

October 31, 2018. This matter requests the Board authorize the Clerk to publish a notice declaring the Board's intent to execute two lease amendments with the Landlord, to extend the terms of these leases for five years through November 30, 2023 and October 31, 2023; and to specify rents for the extended terms.

Discussion:

Women, Infants, and Children, Driving Under the Influence, and Whole Person Care Programs. In November 2006, the County entered into a lease with the landlord, Kirk Veale ("Landlord"), for 583 sq. ft. of office space (Suites F, H, I and J), located at 16390 Main Street, in Guerneville. The term of the lease expires on November 30, 2018. Pursuant to the lease, County may continue to occupy and use this space on a month-to-month basis after the term expires.

Department of Health Services ("Health Services") currently utilizes this space for the Women, Infants, and Children and the Driving Under the Influence programs. In the near future, Health Services Whole Person Care case management staff will utilize the space twice a week. Space will also be available for other County programs that are not currently able to sustain satellite offices in Guerneville (i.e., programs operated by Child Support Services, Human Services, Community Development Commission, and Probation). The co-location of these services, even for limited hours each week, will provide for better coordination of services for shared clients and better service for the Guerneville community. Additional program information is provided below.

- The Women, Infants, and Children program provides specific supplemental nutritious food and nutrition education to a specific target population as a short-term intervention and as an adjunct to ongoing health care. The supplemental foods provided by the Women, Infants, and Children program are designed to meet the participant's enhanced dietary needs for specific nutrients during brief but critical periods of physiological development. It is "short-term" in that on average, Women, Infants, and Children program participants receive services for approximately two years.
- The Driving Under the Influence program provides education classes and individual sessions for individuals who have been convicted of a drunk-driving offence. The program serves approximately 2,000 individuals annually through sites in Santa Rosa, Guerneville, Sonoma, and Petaluma.
- The Whole Person Care program provides outreach, engagement and intensive case management services for Medi-Cal clients who are experiencing homelessness or are at-risk of homelessness and a mental health condition, as well as substance use disorders and/or chronic health conditions and/or are high utilizers of emergency services. The program aims to increase the use of appropriate supportive services (behavioral health treatment, Federally Qualified Health Centers, housing services, etc.) by traditionally hard to engage clients.

Community Mental Health Center Offices. In October 2007, Health Services entered into a second lease with the Landlord, for 1,748 sq. ft. of office space (Suite B) at 16390 Main Street, Guerneville. This site is part of the Behavioral Health Division's Community Mental Health Centers program. The Guerneville Community Mental Health Center program provides services to 100 adults with serious mental illness who are homeless and/or have co-occurring alcohol and other drug problems. Regionally-based Centers provide intensive community services and support as well as enhanced mental health services throughout Sonoma County at sites in Guerneville, Petaluma, Sonoma, and Cloverdale.

In July 2018, your Board approved execution of a lease amendment to expand the leased premises by 170 sq. ft. (Suite G), to provide office space for the Health Services' Mobile Support Team, which

provides crisis management, assessment of individual and family member needs, and linkage and referral to treatment services and other community resources as needed. The term of the lease expired on October 31, 2018, and the County is leasing this office space on a month-to-month basis pending execution of the proposed amendment.

The two leases were originally executed separately, since the offices were utilized for different programs and functions (i.e., Public Health and Behavioral Health). In addition, keeping the leases separate provides flexibility for County, in the event an office space is no longer needed, which might necessitate termination of a lease.

County Comprehensive Facilities Plan. The County Comprehensive Facility Plan (“Plan”) recommends increased consolidation of core Health Services functions to achieve more efficient and effective service delivery. The Plan also recognizes that some services are best delivered or accessed at locations that are more convenient to the target community. General Services and Health Services staff have evaluated the need for leased space throughout the County to support the Plan. Leased spaces in Petaluma, Guerneville, and Cloverdale are utilized to support the Plan. Behavioral health services are provided in County-owned space in the Sonoma Valley. Health Services is also in the process of expanding the Mobile Support Team to provide services in the Sonoma Valley through the Petaluma Office. Additionally, Sonoma Valley residents are offered Women, Infants, and Children program services and will be offered Whole Person Care services out of the Sonoma Valley Community Health Center.

Offering these services in West Sonoma County allows Health Services to collaborate with other local social service providers, including West County Community Services, Russian River Counselors, River to Coast Child Care Services, Face to Face, and West County Health Services. As Health Services intends to continue its programs at these locations for years to come, the County prioritizes execution of the proposed lease amendments.

Rental Analysis: These offices are located in Guerneville in rural West County. This submarket has an extremely limited supply of commercial office space available for lease. As a result, rental rates are relatively high. A recent survey of the market did not identify any alternative properties suitable for Health Services’ needs. Taking into account the types of programs and services being offered, the amount of space required at each site, the limited availability in Guerneville and resultant rental rates in the area, the proposed rents for the amendments (\$2.26 per sq. ft. and \$2.78 per sq. ft.) are reasonable and within budget for the proposed use.

Proposed Lease Amendment Terms. Staff has negotiated terms for the proposed lease amendments, as follows:

Women, Infants, and Children / Driving Under the Influence Program Offices (Suites F, H, I and J, 16390 Main Street; 583 sq. ft.):

- | | |
|--------------|--|
| Term: | Extended through November 30, 2023. |
| Rent: | Rent will be increased by 3%, from \$2.70 per sq. ft. to \$2.78 per sq. ft. (\$1,622 per month) effective December 1, 2018 through November 30, 2019, subject to 3% increases thereafter on December 1 st of each year. |
| Termination: | County may terminate the lease with 30 days’ written notice for non-appropriation of funds, and for any reason with 60 days’ prior written notice. |

Community Mental Health Center (Suites B and G, 16390 Main Street; 1,918 sq. ft.):

- Term: Extended through October 31, 2023.
- Rent: Rent for the original premises (1,748 sq. ft.) will be increased by 3%, from \$2.19 per sq. to \$2.26 per sq. ft. (\$4,401 per month) effective November 1, 2018, subject to 3% increases thereafter on November 1st of each year.
- Rent for the expansion premises (Suite G, 170 sq. ft.) will be held flat at the current rate of \$2.65 per sq. ft. for the term of the extension.
- Termination: County may terminate the lease with 30 days' written notice for non-appropriation of funds, and for any reason with 60 days' prior written notice.

Procedural Authority. Government Code Section 25350 requires two (2) Board actions, which includes publication of a notice of intent, for the County to lease real property as tenant, and the lease agreement is valued at more than \$50,000. If your Board takes the requested actions, this matter will return to the Board on or after December 11, 2018, for consideration and consummation of the proposed lease amendments in line with the Government Code.

Prior Board Actions:

Suites F, H, I and J (WIC and DUI Program Offices) lease:

- 09/10/13—Authorized General Services Director, or his Deputy, to execute 1st amendment
07/30/13—Declared intent to enter into 1st amendment

Suites B and G (Community Mental Health Center) lease:

- 07/10/18 – Authorized General Services Director to execute 2nd amendment to expand the premises
06/11/18—Declared intent to enter into 2nd amendment
09/10/13—Authorized General Services Director to execute 1st amendment
07/30/13—Declared intent to enter into 1st Amendment
10/09/07—Authorized General Services Director, or his Deputy, to execute lease
09/11/07—Declared intent to enter into lease with Kirk Veale

Strategic Plan Alignment Goal 1: Safe, Healthy, and Caring Community

At this Guerneville location, the County Department of Health Services partners with other service agencies, including West County Community Services, Russian River Counselors, River to Coast Child Care Services, Face to Face, and West County Health Services, to provide a broad array of safety-net services to families and individuals residing in West Sonoma County. The proposed lease amendments will provide continuity in the delivery of Behavioral and Public Health services to Health Services clients, who reside in the Guerneville and West County communities.

Fiscal Summary			
Expenditures	FY 18-19 Adopted	FY 19-20 Projected	FY 20-21 Projected
Budgeted Expenses	71,582.75	73,595.98	75,658.44
Additional Appropriation Requested	0		
Total Expenditures	71,582.75	73,595.98	75,658.44
Funding Sources			
General Fund/WA GF	0		
State/Federal	70,131.55	72,101.24	74,118.86
Fees/Other	1,451.20	1,494.74	1,539.58
Use of Fund Balance	0		
Contingencies	0		
Total Sources	71,582.75	73,595.98	75,658.44
Narrative Explanation of Fiscal Impacts:			
<p>Funding for rent costs is provided by Women, Infants, and Children Grant, Driving Under the Influence fees, Triage Grant for Mobile Support Team, Whole Person Care, Mental Health Services Act, Federal Financial Participation, and Mental Health Realignment. Rent and projected increases were budgeted in FY 18-19. No additional appropriations are required.</p> <p>16390 Main Street, Suites F, H, I and J (Public Health Women, Infants, and Children and Driving Under the Influence Program Offices (583 sq. ft.): Rent costs for the lease are \$1,574.81 monthly for the months of July 2018 through November 2018, with a 3% increase in rent to \$1,622.06 per month for the months of December 2018 through June 2019. Total rent for FY 18-19 under the existing lease and as proposed for amendment will be \$19,228.47. Pursuant to the proposed lease amendment, rent is adjusted by 3% annually on December 1st of each year of the 5-year extension period.</p> <p>16390 Main Street, Suites B and G (Community Mental Health Center (1,918 sq. ft.)): Rent costs for the lease are \$4,286.61 monthly for the months of July 2018 through October 2018, with a 3% increase in rent to \$4,400.98 per month for the months of November 2018 through June 2019. Total rent for FY 18-19 under the existing lease and as proposed for amendment will be \$52,354.28. Pursuant to the proposed lease amendment, rent is adjusted by 3% annually on November 1st of each year of the 5-year extension period.</p>			
Staffing Impacts			
Position Title (Payroll Classification)	Monthly Salary Range (A – I Step)	Additions (Number)	Deletions (Number)

Narrative Explanation of Staffing Impacts (If Required):

None.

Attachments:

Attachment 1: Premises

Attachment 2: Notice of Intent

Attachment 3: Proposed amendments (2)

Related Items "On File" with the Clerk of the Board:

None.

**PUBLIC NOTICE
OF INTENT OF COUNTY
TO AMEND LEASES OF
REAL PROPERTY**

NOTICE IS GIVEN that the Sonoma County Board of Supervisors intends to amend that certain lease dated November 22, 2006, for premises located at 16390 Main Street, Suites F,s H, I and J, Guerneville, California, comprised of five hundred eighty-three (583) sq. ft. of office space (the "2006 Lease"), and that certain lease dated October 9, 2007, for premises located at 16390 Main Street, Suites B and G, Guerneville, California, comprised of one thousand nine hundred eighteen (1,918) sq. ft. of office space (the "2007 Lease").

The Board intends to amend these leases, such that: (i) the lease term for the 2006 Lease shall be extended through November 30, 2023, and the monthly rent shall be One Thousand Six Hundred Twenty-Two Dollars and 06/100 Dollars (\$1,622.06), subject to annual escalation; (ii) the 2007 Lease shall be extended through October 31, 2023; and the monthly rent shall be Four Thousand Four Hundred and 98/100 Dollars (\$4,400.98), subject to annual escalation; and (iii) other terms and conditions of the leases will be modified as more particularly set forth in the respective lease amendments.

Additional information regarding the proposed lease amendments for 16390 Main Street, Guerneville, California, are available for public review at the Office of the Director of the General Services Department, 2300 County Center Drive, Suite A200, Santa Rosa, California 95403. The Board of Supervisors will meet on December 11, 2018, at 8:30 a.m., at the Sonoma County Administration Building, Room 102A, 575 Administration Drive, Santa Rosa, California to consummate the lease amendments.

Clerk of the Board of Supervisors

Public notice of the County's intention to amend the leases for the Property shall be published once per week for three successive weeks in accordance with Government Code Section 25350 and 6063.

SECOND AMENDMENT TO LEASE

This Second Amendment ("Second Amendment"), dated as of _____, 2018 ("Effective Date"), is by and between **KIRK VEALE d/b/a VEALE INVESTMENT PROPERTIES** ("Landlord"), and the **COUNTY OF SONOMA**, a political subdivision of the State of California ("Tenant"). All capitalized terms used herein shall, unless otherwise defined, have the meaning ascribed to those terms in the Agreement (as defined below). Landlord and Tenant are sometimes collectively referred to herein as the "parties" and singularly, a "party."

R E C I T A L S

WHEREAS, Landlord and Tenant entered into that certain Lease dated November 22, 2006 ("Lease"), for use of office space comprising five hundred eighty-three (583) useable square feet in that certain office building known as the former Bank of America building, located at 16390 Main Street, in the unincorporated area of Sonoma County, California, commonly known as Guerneville ("Premises"); and

WHEREAS, Landlord and Tenant entered into that certain First Amendment to Lease dated May 24, 2013 ("First Amendment"), in order to, among other things, extend the term through November 30, 2016, specify the rent for the lease extension, and provide for two (2) one-year options to extend the term of the Lease; and

WHEREAS, by letter dated September 28, 2016, Tenant properly exercised its first option to extend the term through October 31, 2017 ("First Option Notice"); and

WHEREAS, by letter dated September 11, 2017, Tenant properly exercised its second option to extend the term through November 30, 2018 ("Second Option Notice"); and

WHEREAS, the Original Lease as modified by the First Amendment, the First Option Notice and the Second Option Notice is hereafter referred to as the "Lease"; and

WHEREAS, Landlord and Tenant wish to amend the Lease in order to: (i) extend the Lease term; (ii) specify the Rent; and (iii) provide for certain other terms and conditions as hereinafter set forth.

NOW, THEREFORE, in consideration of the continued use of the Premises, and for other good and valuable consideration the receipt and sufficiency of which is hereby acknowledged, the parties hereto mutually agree as follows:

A G R E E M E N T

1. The foregoing recitals are true and correct and are hereby incorporated and made a part of this Second Amendment.

2. Effective as of the Effective Date of this Second Amendment, the Lease is modified as follows:

A. Section 2.1 is hereby deleted in its entirety and replaced with the following:

“2.1 Term. The initial term (“Initial Term”) of this Lease shall commence December 1, 2006 (“Commencement Date”) and expire on November 30, 2023, subject to any option, renewal, extension or termination rights of Tenant as provided for in this Lease.”

B. Section 4.2 is hereby deleted in its entirety and replaced with the following:

“4.2 Rental Amount. Tenant shall pay to Landlord in lawful money of the United States, the following:

- a) December 1, 2006 – November 30, 2007 \$1,340.90 per month;
- b) December 1, 2007 – November 30, 2008 \$1,381.13 per month;
- c) December 1, 2008 – November 30, 2011 \$1,422.56 per month;
- d) December 1, 2011 – November 30, 2013 \$1,465.25 per month;
- e) December 1, 2013 – November 30, 2014 \$1,399.20 per month;
- f) December 1, 2014 – November 30, 2015 \$1,441.18 per month;
- g) December 1, 2015 – November 30, 2016 \$1,484.41 per month;
- h) December 1, 2016 – November 30, 2017 \$1,528.94 per month;
- i) December 1, 2017 – November 30, 2018 \$1,574.81 per month;
- j) December 1, 2018 – November 30, 2019 \$1,622.06 per month;
- k) December 1, 2019 – November 30, 2020 \$1,670.72 per month;
- l) December 1, 2020 – November 30, 2021 \$1,720.84 per month;
- m) December 1, 2021 – November 30, 2022 \$1,772.46 per month;
- n) December 1, 2022 – November 30, 2023 \$1,825.64 per month.”

3. Except to the extent the Lease is specifically and expressly amended or supplemented hereby, the Lease, together with exhibits is, and shall continue to be, in full force and effective as originally executed, and nothing contained herein shall, or shall be constructed to modify, invalidate or otherwise affect any provision of the Lease or any right of Tenant or Landlord arising thereunder.

4. This Second Amendment shall be governed by and construed under the internal laws of the State of California, and any action to enforce the terms of this Second Amendment or for the breach thereof shall be brought and tried in the County of Sonoma.

LANDLORD AND TENANT HAVE CAREFULLY READ AND REVIEWED THIS SECOND AMENDMENT AND EACH TERM AND PROVISION CONTAINED HEREIN AND, BY EXECUTION OF THIS SECOND AMENDMENT, SHOW THEIR INFORMED AND VOLUNTARY CONSENT THERETO.

IN WITNESS WHEREOF, the parties have executed this Second Amendment as of the Effective Date.

LANDLORD: **KIRK VEALE, d/b/a VEALE INVESTMENT PROPERTIES**

By: _____
Name: _____
Title: _____

TENANT: **COUNTY OF SONOMA**, a political subdivision of the State of California

By: _____
Caroline Judy, Director
General Services Department

The General Services Director is authorized to execute this Second Amendment, pursuant to the Board of Supervisors Action dated _____, 2018.

APPROVED AS TO FORM FOR TENANT:

Elizabeth Coleman With
Deputy County Counsel

APPROVED AS TO SUBSTANCE FOR TENANT:

Marc McDonald
Real Estate Manager

Barbie Robinson, Director
Department of Health Services

CERTIFICATE OF INSURANCE ON FILE WITH DEPARTMENT:

Reviewed by: _____ Date: _____

THIRD AMENDMENT TO LEASE

This Third Amendment ("Third Amendment"), dated as of _____, 2018 ("Effective Date"), is by and between **KIRK VEALE d/b/a VEALE INVESTMENT PROPERTIES** ("Landlord"), and the **COUNTY OF SONOMA**, a political subdivision of the State of California ("Tenant"). All capitalized terms used herein shall, unless otherwise defined, have the meaning ascribed to those terms in the Agreement (as defined below). Landlord and Tenant are sometimes collectively referred to herein as the "parties" and singularly, a "party."

R E C I T A L S

WHEREAS, Landlord and Tenant entered into that certain Lease dated October 9, 2007 ("Original Lease"), for use of Suite B, comprising one thousand seven hundred forty-eight (1,748) useable square feet in that certain office building known as the former Bank of America building, located at 16390 Main Street, in the unincorporated area of Sonoma County, California, commonly known as Guerneville ("Premises"); and

WHEREAS, Landlord and Tenant entered into that certain First Amendment to Lease dated May 24, 2013 ("First Amendment"), in order to, among other things, extend the term through October 31, 2016, and specify the rent for the lease extension; and

WHEREAS, by letter dated September 28, 2016, Tenant properly exercised its first option to extend the term through October 31, 2017 ("First Option Notice"); and

WHEREAS, by letter dated September 11, 2017, Tenant properly exercised its second option to extend the lease term through October 31, 2018 ("Second Option Notice"); and

WHEREAS, Landlord and Tenant entered into that certain Second Amendment to Lease dated July 13, 2018 ("Second Amendment"), in order to redefine the Premises to expand into Suite G, comprised of one hundred seventy (170) sq. ft., and to specify Rent to include the Suite G premises; and

WHEREAS, the Original Lease as modified by the First Amendment, the First Option Notice, the Second Option Notice, and the Second Amendment is hereafter referred to as the "Lease"; and

WHEREAS, Landlord and Tenant wish to further amend the Lease in order to: (i) extend the Lease term; (ii) specify the Rent; and (iii) provide for certain other terms and conditions as hereinafter set forth.

NOW, THEREFORE, in consideration of the continued use of the Premises, and for other good and valuable consideration the receipt and sufficiency of which is hereby acknowledged, the parties hereto mutually agree as follows:

A G R E E M E N T

1. The foregoing recitals are true and correct and are hereby incorporated and made a part of this Third Amendment.

2. Effective as of the Effective Date of this Third Amendment, the Lease is modified as follows:

A. Section 2.1 is hereby deleted in its entirety and replaced with the following:

“2.1 Term. The initial term (“Initial Term”) of this Lease shall commence December 1, 2006 (“Commencement Date”) and expire on October 31, 2023, subject to any option, renewal, extension or termination rights of Tenant as provided for in this Lease.”

B. Section 4.2 is hereby deleted in its entirety and replaced with the following:

“4.2 Rental Amount. Tenant shall pay to Landlord in lawful money of the United States, the following:

a)	November 1, 2007 through October 31, 2008	\$3,146.40 per month;
b)	November 1, 2008 through October 31, 2009	\$3,240.79 per month;
c)	November 1, 2009 through October 31, 2010	\$3,338.02 per month;
d)	November 1, 2010 through October 31, 2011	\$3,438.16 per month;
e)	November 1, 2011 through October 31, 2013	\$3,541.31 per month;
f)	November 1, 2013 through October 31, 2014	\$3,408.60 per month;
g)	November 1, 2014 through October 31, 2015	\$3,510.86 per month;
h)	November 1, 2015 through October 31, 2016	\$3,616.18 per month;
i)	November 1, 2016 through October 31, 2017	\$3,724.67 per month;
j)	November 1, 2017 through July 12, 2018	\$3,836.41 per month;
k)	July 13, 2018 through October 31, 2018	\$4,286.41 per month;
l)	November 1, 2018 through October 31, 2019	\$4,400.98 per month;
m)	November 1, 2019 through October 31, 2020	\$4,523.34 per month;
n)	November 1, 2020 through October 31, 2021	\$4,645.70 per month;
o)	November 1, 2021 through October 31, 2022	\$4,768.06 per month;
p)	November 1, 2022 through October 31, 2023	\$4,907.90 per month”

3. Except to the extent the Lease is specifically and expressly amended or supplemented hereby, the Lease, together with exhibits is, and shall continue to be, in full force and effective as originally executed, and nothing contained herein shall, or shall be constructed to modify, invalidate or otherwise affect any provision of the Lease or any right of Tenant or Landlord arising thereunder.

4. This Third Amendment shall be governed by and construed under the internal laws of the State of California, and any action to enforce the terms of this Third Amendment or for the breach thereof shall be brought and tried in the County of Sonoma.

LANDLORD AND TENANT HAVE CAREFULLY READ AND REVIEWED THIS THIRD AMENDMENT AND EACH TERM AND PROVISION CONTAINED HEREIN AND, BY EXECUTION OF THIS THIRD AMENDMENT, SHOW THEIR INFORMED AND VOLUNTARY CONSENT THERETO.

IN WITNESS WHEREOF, the parties have executed this Third Amendment as of the Effective Date.

LANDLORD: **KIRK VEALE, d/b/a VEALE INVESTMENT PROPERTIES**

By: _____
Name: _____
Title: _____

TENANT: **COUNTY OF SONOMA**, a political subdivision of the State of California

By: _____
Caroline Judy, Director
General Services Department

The General Services Director is authorized to execute this Third Amendment, pursuant to the Board of Supervisors Action dated _____, 2018.

APPROVED AS TO FORM FOR TENANT:

Jeremy Fonseca
Deputy County Counsel

APPROVED AS TO SUBSTANCE FOR TENANT:

Marc McDonald
Real Estate Manager

Barbie Robinson, Director
Department of Health Services

CERTIFICATE OF INSURANCE ON FILE WITH DEPARTMENT:

Reviewed by: _____ Date: _____



County of Sonoma Agenda Item Summary Report

Clerk of the Board
575 Administration Drive
Santa Rosa, CA 95403

Agenda Item Number: 26
(This Section for use by Clerk of the Board Only.)

To: Sonoma County Board of Supervisors

Board Agenda Date: November 13, 2018

Vote Requirement: Majority

Department or Agency Name(s): General Services

Staff Name and Phone Number:

Caroline Judy: 707-565-8058

Supervisorial District(s):

5th

Title: 2018 Guerneville Winter Shelter License Agreement

Recommended Actions:

- A. Authorize the Director of General Services to execute a revocable license agreement with West County Community Services for the 2018 Winter Shelter located at the Guerneville Veterans Memorial Veterans Building commencing on December 1, 2018 and terminating on March 31, 2019, to provide housing to the homeless through the winter months.
- B. Make findings in accordance with Section 26227 of the Government Code that the services provided by the licensee will serve public purposes and that the property subject to the license will not be needed for County purposes during the time of the licensee's possession.

Executive Summary:

West County Community Services (WCCS), formerly Community Family and Services Agency, sponsors an annual winter homeless shelter for homeless residents in West County and throughout Sonoma County. The proposed license agreement would be in the amount of \$27,000, in payments to the County of \$6,750 per month for each of the four months that the shelter is in operation. The winter shelter provides a critical service need for the homeless population in the Russian River area.

Discussion:

The winter shelter has been operating since 2010 primarily from the Guerneville Veterans Memorial Building. The Guerneville Veterans Memorial Building is used due to a lack of other available facilities in the area. The winter shelter program provides emergency food and shelter during the wettest and coldest months, and aims to improve the long-term housing status of as many residents as possible. The shelter is open 7 days a week from 5:00 p.m. to 7:00 a.m. with services including food, bedding, shower facilities, and limited supplies for daily needs.

Approximately 70% of the winter shelter residents come from the lower Russian River area, 20% from the remainder of Sonoma County, and 10% come from outside the County. The shelter employs one full time employee and twelve part time employees with various shifts.

In 2017, the winter shelter served 4,753 dinners, 4,610 lunches, and provided up to 57 beds per night for 160 unduplicated clients.

Public Benefit

Government Code Section 26227 allows the Board of Supervisors to “contract with other public agencies or private agencies or individuals to operate those programs which the Board of Supervisors determines will serve public purposes. In the furtherance of those programs, the Board of Supervisors may make available any real property of the County which is not and, during the time of possession, will not be needed for County purposes, to be used to carry out the programs, upon terms and conditions determined by the Board of Supervisors to be in the best interests of the County and the general public.” Staff is recommending and requesting that the Board find that the services provided by this licensee will serve public purposes and that the property subject to the license will not be needed for County purposes during the time-periods indicated of the licensee’s possession.

Prior Board Actions:

07/10/18 – Approved CDC Funding Awards including \$140,000 to WCCS for Winter Shelter Operation
01/09/18 – Approved 2017 Winter Shelter Agreement

Strategic Plan Alignment Goal 1: Safe, Healthy, and Caring Community

Fiscal Summary

Expenditures	FY 18-19 Adopted	FY 19-20 Projected	FY 20-21 Projected
Budgeted Expenses	27,000		
Additional Appropriation Requested			
Total Expenditures	27,000		

Funding Sources

General Fund/WA GF			
State/Federal			
Fees/Other	27,000		
Use of Fund Balance			
Contingencies			
Total Sources	27,000		

Narrative Explanation of Fiscal Impacts:

The total rental cost for use of the Guerneville Veterans Building for the annual winter homeless shelter is \$166,507. This includes 93 days of operation for each of the 3 rentable rooms in the building. General Services will receive \$27,000 from CDC through this agreement for the use of the facility. Consistent with prior Board direction, the use of the facility is provided at a substantially reduced rate in order to maximize the availability of winter shelter services.

Staffing Impacts

Position Title (Payroll Classification)	Monthly Salary Range (A – I Step)	Additions (Number)	Deletions (Number)

Narrative Explanation of Staffing Impacts (If Required):

Attachments:

Attachment 1: 2018 Winter Shelter Agreement

Related Items “On File” with the Clerk of the Board:

--

REVOCABLE LICENSE AGREEMENT FOR USE OF COUNTY FACILITIES

This Revocable License Agreement ("Agreement"), made and entered into on _____, ("Effective Date"), is by and between the **COUNTY OF SONOMA**, a political subdivision of the State of California ("County"), and **WEST COUNTY COMMUNITY SERVICES**, a NON-PROFIT ("Licensee"). County and Licensee are sometimes collectively referred to herein as the "parties" and singularly, a "party."

RECITALS

WHEREAS, County owns the building commonly known as the Guerneville Veterans Memorial Building, located at First and Church Street, Guerneville, California; and,

WHEREAS, the Licensee desires to utilize the premises at certain times as more particularly described below for the purpose of providing Winter shelter to people in need; and

WHEREAS, the County recognizes that entering into an agreement with the Licensee for the use of the Premises described in Section 2 below is in the best interest of the general public of the County; and

NOW, THEREFORE, in consideration of the Premises and of the agreements of the respective parties herein set forth, it is mutually agreed as follows:

AGREEMENT

1. License. The County hereby grants Licensee a license, subject to all the terms and conditions of this Agreement, to use that portion of County real property described in Section 2 below.
2. Premises. Licensee is hereby permitted to use the County real property as specifically shown or described in **Exhibit A** attached hereto and made a part hereof ("Premises").
3. Non-exclusive License. The license herein granted is non-exclusive. County continues to maintain and control the Premises including, without limitation, leasing, sub-leasing, permitting and granting of additional licenses.
4. Term. The term of this Agreement ("Initial Term") shall commence on December 1, 2018, and expiring at midnight on March 31, 2019, unless earlier terminated in accordance with Section 23 below.
5. Consideration. Licensee shall pay the County of Sonoma for the agreed use of said Premises as follows: Six Thousand Seven Hundred and Fifty Dollars (\$6,750) no less than ten business days prior to the first day of each month of Licensee's use of said Premises.
6. **DELETED**

7. Use. Licensee's use shall be limited to uses described in **Exhibit B**. No other use shall be permitted. The rules and regulations attached hereto as **Exhibit C**, as well as such rules and regulations as may be adopted by County and provided to Licensee for the safety, care and cleanliness of the Premises and the building of which they are a part and the preservation of good order thereon are hereby expressly made a part hereof, and Licensee hereby agrees to comply with them. Licensee shall be solely responsible for any cost or expense for any and all maintenance and/or repairs required by County or by County's Permit & Resource Management Department ("PRMD"), including without limitation, alterations or repairs necessitated by the Americans with Disabilities Act. (See Section 10.1.)
8. Utilities/Repairs/Maintenance. Licensee shall reimburse County for the cost of any repair(s) that is needed to the Premises, as a result of Licensee's negligence or willful acts. Reimbursements due to County for the cost of any repair that is needed as a result of Licensee's negligence or willful acts shall be paid to County within thirty (30) days of receipt of invoice by Licensee for said repairs.
9. Equipment Installation and Operation. Licensee shall install the equipment, described in **Exhibit D**, at its sole cost and expense, subject to the prior written approval of County of its location and connection methods. Licensee's equipment shall be installed, operated and maintained in accordance with the highest standards now or hereafter generally employed for similar equipment. In the event the installation, operation or maintenance of said equipment causes any direct or indirect interference with the operation of County's facilities, equipment or the equipment of County's tenants, or other licensees, Licensee shall correct said interference, at its sole cost and expense, to the satisfaction of County. In the event said interference cannot be corrected, Licensee shall promptly remove said equipment.
10. Taxes. Licensee agrees to pay any and all lawful taxes, assessments, or charges which may at any time be levied by any public entity upon any improvements made as a result of this Agreement.
11. Possessory Interest. Licensee expressly recognizes and understands that this Agreement may create a possessory interest subject to property taxation and that Licensee may be subject to the payment of property taxes levied on such interest.
12. Compliance with Laws. Licensee has represented to County and hereby warrants that Licensee has complied with all laws applicable to the acceptance and use of the license herein granted. Licensee shall observe and comply at all times with all applicable federal, state and county statutes and ordinances, rules, regulations, directives, and orders of governmental agencies now in force or which may hereinafter be in force relating to or affecting the use of the license herein granted. Licensee understands that this Agreement solely grants Licensee permission to use the Premises. Obtaining any permits or additional permissions required by any entity or agency, including County, as a condition for Licensee to lawfully and properly use the Premises as contemplated by this Agreement shall be the sole responsibility of Licensee. Nothing in this Agreement shall be construed as regulatory permission for the usage of the Premises by Licensee for such purposes.
13. Waste; Nuisance. Licensee shall not commit, suffer, or permit the commission by others of: (i) any waste or nuisance on the Premises; (ii) any action or use of the Premises

which interferes or conflicts with the use of the Premises by County or any authorized person; or (iii) any action on the Premises in violation of any laws or ordinances.

14. Inspection. County shall be permitted to enter and inspect the licensed Premises at any and all times.
15. Extent of Grant of License. This Agreement and the license herein granted are valid only to the extent of County's jurisdiction as a land owner or tenant of the Premises. Acquisition of any other necessary permits or entitlements for use are the responsibility of Licensee. NOTHING CONTAINED IN THIS AGREEMENT SHALL BE CONSTRUED AS A RELINQUISHMENT OF ANY RIGHTS NOW HELD BY COUNTY.
16. Deposit Refund. Licensee agrees that the deposit, if any be required, made upon execution by Licensee of this Agreement shall not be refundable for any reason unless County, in its absolute discretion, determines such a refund in whole or in part, to be warranted.
17. Bankruptcy. In the event of bankruptcy of Licensee or writ of attachment of execution against Licensee, this Agreement shall, at the option of the County, immediately terminate.
18. Non liability of County. County, its officers, agents, and employees shall not be liable to Licensee for any loss or damage to Licensee or Licensee's property from any cause. Licensee expressly waives all claims against County, its officers, agents, and employees, unless such injury or damage is caused by or due to the sole negligence or willful misconduct of County, its officers, agents, and employees. Licensee hereby agrees to accept the Premises in its "as-is" physical condition and its "as-is" state of repair.
19. Indemnification. Licensee agrees to accept all responsibility for loss or damage to any person or entity, including but not limited to County, and to defend, indemnify, hold harmless, reimburse and release County, its officers, agents, and employees, from and against any and all actions, claims, damages, disabilities, liabilities and expense, including but not limited to attorneys' fees and the cost of litigation incurred in the defense of claims as to which this indemnity applies or incurred in an action by County to enforce the indemnity provisions herein, whether arising from personal injury, property damage or economic loss of any type, that may be asserted by any person or entity, including Licensee, arising out of or in connection with any of the circumstances described in Sections 19.1, 19.2, 19.3 and 19.4, whether or not there is concurrent negligence on the part of County, but, to the extent required by law, excluding liability due to the sole or active negligence or due to the willful misconduct of County. If there is a possible obligation to indemnify, Licensee's duty to defend exists regardless of whether it is ultimately determined that there is not a duty to indemnify. County shall have the right to select its own legal counsel at the expense of Licensee, subject to Licensee's approval, which approval shall not be unreasonably withheld. This indemnification obligation is not limited in any way by any limitation on the amount or type of damages or compensation payable to or for Licensee or its agents under workers' compensation acts, disability benefits acts, or other employee benefit acts.

19.1 Use of Premises. Use of the Premises in any manner by Licensee, its agents, employees, invitees, subtenants, licensees and contractors, and the agents, employees,

- patrons, contractors and invitees of subtenants, including any use of the Premises not allowed under this Agreement.
- 19.2 Breach by Licensee. Any breach by Licensee of the terms, covenants or conditions herein contained.
- 19.3 Approval of Agreement. The approval of this Agreement by County.
- 19.4 Other Activities. Any other activities of Licensee, its agents, employees and subtenants.
20. Insurance. With respect to the rights granted hereunder, Licensee shall maintain and shall require all of its subcontractors to maintain insurance as described in **Exhibit E** attached hereto and made a part hereof.
21. Liability for Loss or Damage to County Property. Licensee shall be liable to County for any loss or damage to the Premises arising from or in connection with Licensee's performance hereunder or any of its officers, agents, and employees.
22. Nondiscrimination. In the performance of this Agreement, Licensee shall comply with all applicable federal, state and local laws, rules and regulations regarding nondiscrimination in employment because of race, color, ancestry, national origin, religion, sex, sexual orientation, marital status, age, medical condition or disability.
23. Termination by County. County may terminate this Agreement for any reason whatsoever upon thirty (30) days prior written notice to Licensee.
24. License is Personal. The license herein granted is personal to Licensee and no right hereunder may be assigned, sublet, or otherwise transferred in whole or in part without the prior written consent of County, and any attempt to assign, sublet or transfer shall be of no force or effect whatsoever unless and until County shall have given its written consent thereto. County may withhold its consent for any reason.
25. Provisions are Conditions of Use/Occupancy. Each provision of this Agreement shall be deemed a condition of the right of Licensee to use or continue to occupy the Premises. Notwithstanding anything stated to the contrary herein, if Licensee fails to perform any provision of this Agreement at the time and in the manner herein provided, County may at its option immediately terminate this Agreement; this right to terminate shall be cumulative to any other legal right or remedy available to County.
26. Licensee to Act in Independent Capacity. Licensee, its officers, agents, and employees shall act in an independent capacity and shall not represent themselves to be or be construed to be officers, agents, or employees of County.
27. License Not a Lease. This Agreement does not constitute a lease, but constitutes a mere revocable license and Licensee is limited to the use of the Premises expressly and specifically described above. If access routes are not specifically described in Section 2 of this Agreement, Licensee shall be entitled to use only the access route(s) designated by the County. Licensee shall have no right or privilege in any respect whatsoever to use any other part of the property of County for any purpose whatsoever. Licensee disclaims

any interest that when coupled with the license herein granted would render it irrevocable.

28. Notice. Any notice required or permitted to be given under this Agreement shall be in writing. Delivery of such written notice shall be conclusively taken as sufficiently given forty-eight (48) hours after deposit in the United States Mail, registered or certified, return receipt requested, with the postage thereon fully prepaid, addressed as follows:

If to COUNTY: County of Sonoma
General Services Department
Attn. Real Estate Manager
2300 County Center Drive, Suite A200
Santa Rosa, CA 95403

If to LICENSEE: West County Community Services
Attn. Tim Miller
P.O. Box 325
Guerneville, CA 95446

Either party may at any time change its address for notices by giving written notice of such change to the other party in the manner provided in this Section 28.

29. No Continuing Waiver. The waiver by County of any breach of any of the provisions of this Agreement shall not constitute a continuing waiver of any subsequent breach of the same, or of any other provision of this Agreement.
30. Surrender. Upon the expiration or sooner termination of this Agreement, Licensee, at its sole cost and expense, shall remove, revise, or relocate such of its structures and equipment as is designated by County, restore the Premises to its original condition, and vacate the Premises. Should Licensee neglect to restore the Premises to a condition satisfactory to County, County may perform such work or have the work performed, and Licensee shall immediately reimburse County for all direct and indirect costs associated with such work upon receipt of a statement therefor.
31. General Provisions.
- 31.1 Time of Essence. Time is and shall be of the essence of this Agreement and of each and every provision contained in this Agreement.
- 31.2 Incorporation of Prior Agreements; Amendments. This Agreement contains all the agreements of the parties with respect to any matter mentioned herein. No prior agreement, or understanding pertaining to any such matter shall be effective. This Agreement may be modified in writing only, signed by the parties in interest at the time of the modification, and this sentence may not be modified or waived by any oral agreement, whether executed or unexecuted.
- 31.3 Binding Effect; Choice of Law. This Agreement shall be binding upon and inure to the benefit of the parties, their personal representatives, successors, and

assigns. This Agreement shall be governed by the laws of the State of California and any action to enforce the terms of this Agreement or for the breach thereof shall be brought and tried in the County of Sonoma.

- 31.4 Amount Due Payable in U.S. Money. All sums payable under this Agreement must be paid in lawful money of the United States of America.
- 31.5 No Third Party Beneficiaries. Nothing contained in this Agreement shall be construed to create and the parties do not intend to create any rights in third parties.
- 31.6 Construction of Agreement; Severability. To the extent allowed by law, the provisions in this Agreement shall be construed and given effect in a manner that avoids any violation of statute, regulation, or law. County and Licensee agree that in the event any provision in this Agreement is held to be invalid or void by any court of competent jurisdiction, the invalidity of any such provision shall in no way affect any other provision in this Agreement. Licensee and County acknowledge that they have each contributed to the making of this Agreement and that, in the event of a dispute over the interpretation of this Agreement, the language of the Agreement will not be construed against one party in favor of the other. Licensee and County further acknowledge that they have each had an adequate opportunity to consult with counsel in the negotiation and preparation of this Agreement.
- 31.7 Relationship. The parties intend by this Agreement to establish the relationship of licensor and licensee only, and do not intend to create a partnership, joint venture, joint enterprise, or any business relationship other than that of licensor and licensee.
- 31.8 Captions. The captions in this Agreement are for convenience only and are not a part of this Agreement. The captions do not in any way limit or amplify the provisions hereof, and shall have no effect upon the construction or interpretation of any part hereof.

LICENSEE HAS CAREFULLY READ AND CONSIDERED THE TERMS AND CONDITIONS SET FORTH IN THIS AGREEMENT AND HEREBY AGREES THAT LICENSEE SHALL BE BOUND BY ALL SAID TERMS AND CONDITIONS.

IN WITNESS WHEREOF, the parties hereto have executed this Agreement as of the Effective Date.

“LICENSEE”:

WEST COUNTY COMMUNITY SERVICES

By: 

Print Name: Tim Miller

Title: Executive Director

“COUNTY”:

COUNTY OF SONOMA, a political
subdivision of the State of California

By: _____

Caroline Judy, Director
Department of General Services

The General Services Director is authorized to execute this Agreement pursuant to the Board of Supervisors Summary Action dated _____, 20__.

APPROVED AS TO FORM
FOR COUNTY:

Deputy County Counsel

APPROVED AS TO SUBSTANCE
FOR COUNTY:

Real Estate Manager

CERTIFICATE OF INSURANCE
ON FILE WITH DEPARTMENT:

Reviewed by: _____ Date: _____

Exhibit A

[Description/Depiction of the Premises]

Premises shall be those areas of the Guerneville Veteran's Building known as the Auditorium, the Club Room, Ramparts Room, and the Kitchen. Licensee understands and acknowledges that County has entered into agreements with others for use of the Auditorium, the Club Room, Ramparts Room, and the Kitchen. County will make reasonable efforts to avoid conflicting uses. Licensee understands that this agreement does not include use of the Conference Room. Any matters that cannot be resolved between parties shall be resolved by the County, whose decision shall be final.

Exhibit B

[Schedule for Use of the Premises]

Commencing December 1, 2018, Licensee shall Use the Premises for Winter Shelter in accord with the schedule below. Licensee understands and acknowledges that County has entered into agreements with others for use of the Auditorium, the Club Room, Ramparts Room, and the Kitchen. County will make reasonable efforts to avoid conflicting uses. Any matters that cannot be resolved between parties shall be resolved by the County, whose decision shall be final.

Premises and equipment used by Licensee shall be washed and cleaned following each Use of the Premises. Following each use Licensee shall leave the premises in a clean and sanitary condition. Following each use Licensee shall remove from the premises all clothing, supplies, equipment, furnishings and personal property brought on to the premises by Licensee, its invitees, guests and others.

Storage facilities in the vicinity of the Premises may be made available by the County. In such case it will be the responsibility of the Licensee to maintain such facilities.

Licensee may erect fencing on the Premises, subject to County approval of fencing location, design security.

And comply with all the requirements of the County of Sonoma Department of Public Health.

Exhibit C

RULES AND REGULATIONS

1. No sign, placard, picture, advertisement, name or notice shall be inscribed, displayed, printed or affixed on or to any part of the outside or inside of the building of which the Premises are comprised or are a part without the written consent of County first had and obtained, and County shall have the right to remove any such sign, placard, picture, advertisement, name or notice without notice to and at the expense of Licensee.
2. All approved signs or lettering on doors shall be printed, painted, affixed or inscribed at the expense of Licensee by a person approved of by County.
3. Licensee shall not place anything or allow anything to be placed near the glass of any window, door, partition or wall which may appear unsightly from outside the Premises. Licensee shall not, without prior written consent of County, sunscreen any window.
4. The sidewalks, halls, passages, exits, entrances, elevators and stairways shall not be obstructed by Licensee or used for any purpose other than for ingress to and egress from the Premises.
5. Licensee shall not alter any lock or install any new or additional locks or any bolts on any doors or windows of the Premises.
6. The toilet rooms, urinals, wash bowls and other apparatus shall not be used for any purpose other than that for which they were constructed and no foreign substance of any kind whatsoever shall be thrown therein and the expense of any breakage, stoppage or damage resulting from the violation of this rule shall be borne by Licensee.
7. Licensee shall not overload the floor of the Premises or in any way deface the Premises or any part thereof.
8. No furniture, freight or equipment of any kind shall be brought into the Premises without the prior notice to County, and all moving of the same into or out of the building of which the Premises are comprised or are a part shall be done at such time and in such manner as County shall designate. County shall have the right to prescribe the weight, size and position of all safes and other heavy equipment brought into the Premises and also the times and manner of moving the same in and out of the Premises. Safes or other heavy objects shall, if considered necessary by County, stand on support of such thickness as is necessary to properly distribute the weight. County will not be responsible for loss of or damage to any such safe and property from any cause, and all damage done to the building by moving or maintaining any such safe or other property shall be repaired at the expense of Licensee.
9. Licensee shall not use, keep or permit to be used or kept any foul or noxious gas or substance in the Premises, or permit or suffer the Premises to be occupied or used in a manner offensive or objectionable to the County or other occupants of the building of which the Premises are comprised or are a part by reason of noise, odors and/or vibrations, or interfere in any way with other occupants or those having business therein, nor shall any animals or birds be brought in or kept in or about the Premises. Disability assistance animals shall, however, be permitted in the Premises.

10. No cooking shall be done or permitted on the Premises by Licensee, except as permitted and described at Exhibit A, nor shall the Premises be used for the storage of merchandise, for washing clothes, or for any improper, objectionable or immoral purposes.
11. Licensee shall not use or keep in the Premises any kerosene, gasoline or inflammable or combustible fluid or other hazardous material, or use any method of heating or air conditioning other than that supplied by County.
12. County will direct electricians as to where and how telephone and telegraph wires, if any, are to be introduced. No boring or cutting for wires will be allowed without the consent of County. The location of telephones, call boxes and other office equipment affixed to the Premises shall be subject to the approval of County.
13. Except as described at Exhibit B, Licensee shall have access to the Premises and the restrooms in the building between the hours of 4:00 PM and 9:00 AM. County may limit access to the building of which the Premises are a part, or to the halls, corridors, or stairways in the building, or to the Premises with 24 hour advance notice. County shall in no case be liable for damages for any error with regard to the admission to or exclusion from the building or Premises of any person. In case of invasion, mob, riot, public excitement or other commotion, County reserves the right to prevent access to the Premises during the continuance of the same by closing of the doors or otherwise, for the safety of the occupants and protection of property in the building and the building.

In the case of flooding, severe weather or declared emergencies the County may without notice terminate the agreement and take immediate possession of the premises for any use deemed necessary by the County in its sole and exclusive opinion. Such use may, but not shall not be required to include: storage and/or distribution of emergency supplies and equipment, temporary shelter for individuals and/or the general public; distribution and/or service of food, meals, clothing, bedding, etc. to individuals and/or the general public.

14. County reserves the right to exclude or expel from the Premises any person who, in the judgment of County, is intoxicated or under the influence of liquor or drugs, or who shall in any manner do any act in violation of any of these rules and regulations or the Agreement to which these rules and regulations are made a part.
15. No vending machine or machines of any description shall be installed, maintained or operated upon the Premises without the written consent of the County.
16. County shall have the right, exercisable without notice and without liability to Licensee, to change the name and street address of the building of which the Premises are comprised or are a part.
17. Licensee shall not disturb, solicit or canvass any occupant of the building of which the Premises are comprised or are a part and shall cooperate to prevent same.
18. Without the written consent of County, Licensee shall not use the name of the building of which the Premises are comprised or are a part in connection with or in promoting or advertising the business of Licensee except as Licensee's address.

19. County shall have the right to control and operate the public portions of the building of which the Premises are comprised or are a part and the public facilities and heating and air conditioning, as well as facilities furnished for the common use of the occupants, in such manner as it deems best for the benefit of the occupants generally.
20. All entrance doors shall be left locked when the Premises are not in use, and all doors opening to public corridors shall be kept closed except for normal ingress and egress from the Premises.
21. Licensee shall conform to all County of Sonoma requirements in regards to safe food preparation and handling. Additionally, licensee shall provide to the County any and all required permits for food service.

Exhibit D

[Licensee's Equipment]

N/A

Exhibit E

Licensee shall maintain and require its subcontractors and agents to maintain insurance as described below unless such insurance has been expressly waived by the attachment of a *Waiver of Insurance Requirements*.

County reserves the right to review any and all of the required insurance policies and/or endorsements, but has no obligation to do so. Failure to demand evidence of full compliance with the insurance requirements set forth in this Agreement or failure to identify any insurance deficiency shall not relieve Licensee from, nor be construed or deemed a waiver of, its obligation to maintain the required insurance at all times during the performance of this Agreement.

1. Workers Compensation and Employers Liability Insurance

- a. Required if Licensee has employees.
- b. Workers Compensation insurance with statutory limits as required by the Labor Code of the State of California.
- c. Employers Liability with minimum limits of \$1,000,000 per Accident; \$1,000,000 Disease per employee; \$1,000,000 Disease per policy.
- d. Required Evidence of Insurance: Certificate of Insurance.

If Licensee currently has no employees, Licensee agrees to obtain the above-specified Workers Compensation and Employers Liability insurance should any employees be engaged during the term of this Agreement or any extensions of the term.

2. General Liability Insurance

- a. Commercial General Liability Insurance on a standard occurrence form, no less broad than Insurance Services Office (ISO) form CG 00 01.
- b. Minimum Limits: \$1,000,000 per Occurrence; \$2,000,000 General Aggregate; \$2,000,000 Products/Completed Operations Aggregate. The required limits may be provided by a combination of General Liability Insurance and Commercial Excess or Commercial Umbrella Liability Insurance. If Licensee maintains higher limits than the specified minimum limits, County requires and shall be entitled to coverage for the higher limits maintained by Licensee.
- c. Any deductible or self-insured retention shall be shown on the Certificate of Insurance. If the deductible or self-insured retention exceeds \$25,000 it must be approved in advance by County. Licensee is responsible for any deductible or self-insured retention and shall fund it upon County's written request, regardless of whether Licensee has a claim against the insurance or is named as a party in any action involving the County.
- d. **County of Sonoma, its Officers, Agents and Employees** shall be endorsed as additional insureds for liability arising out of Licensee's ongoing operations. (ISO endorsement CG 20 26 or equivalent).
- e. The insurance provided to the additional insureds shall be primary to, and non-contributory with, any insurance or self-insurance program maintained by them.
- f. The policy shall cover inter-insured suits between County and Licensee and include a "separation of insureds" or "severability" clause which treats each insured separately.

g. Required Evidence of Insurance:

- i. Copy of the additional insured endorsement or policy language granting additional insured status; and
- ii. Certificate of Insurance.

3. Automobile Liability Insurance

(Required if (1) autos are used in the event or activity; or (2) the activity involves substantial loading and unloading of property.)

- a. Minimum Limit: \$1,000,000 combined single limit per accident. The required limit may be satisfied by a combination of Automobile Liability Insurance and either Commercial Excess or Commercial Umbrella Liability Insurance.
- b. Insurance shall cover all owned autos. *(Required if Licensee owns vehicles.)*
- c. Insurance shall apply to all hired and non-owned autos.
- d. Required Evidence of Insurance: Certificate of Insurance.

4. Liquor Liability Insurance

(For events with alcohol.)

- a. Minimum Limits: \$1,000,000 for each Common Cause or Occurrence; \$1,000,000 Aggregate.
- b. Any deductible or self-insured retention shall be shown on the Certificate of Insurance. If the deductible or self-insured retention exceeds \$25,000 it must be approved in advance by County. Licensee is responsible for any deductible or self-insured retention.
- c. Required Evidence of Insurance: Certificate of Insurance.

5. Standards for Insurance Companies

Insurers, other than the California State Compensation Insurance Fund, shall have an A.M. Best's rating of at least A:VII.

6. Documentation

- a. The Certificate of Insurance must include the following reference: **2018 Winter Shelter**
- b. All required Evidence of Insurance shall be submitted prior to the execution of this Agreement. Licensee agrees to maintain current Evidence of Insurance on file with County for the required period of insurance.
- c. The name and address for Additional Insured endorsements and Certificates of Insurance is:
County of Sonoma, its Officers, Agents and Employees
Attn: General Services Department
2300 County Center Dr. Suite A200
Santa Rosa, CA 95403
- d. Required Evidence of Insurance shall be submitted for any renewal or replacement of a policy that already exists, at least ten (10) days before expiration or other termination of the existing policy.
- e. Licensee shall provide immediate written notice if: (1) any of the required insurance policies are terminated; (2) the limits of any of the required policies are reduced; or (3) the deductible or self-insured retention is increased.

- f. Upon written request, certified copies of required insurance policies must be provided within thirty (30) days.

7. Policy Obligations

Licensee's indemnity and other obligations shall not be limited by the foregoing insurance requirements.

8. Material Breach

If Licensee fails to maintain insurance which is required pursuant to this Agreement, it shall be deemed a material breach of this Agreement. County, at its sole option, may terminate this Agreement and obtain damages from Licensee resulting from said breach.



County of Sonoma Agenda Item Summary Report

Clerk of the Board
575 Administration Drive
Santa Rosa, CA 95403

Agenda Item Number: 27
(This Section for use by Clerk of the Board Only.)

To: Sonoma County Board of Supervisors

Board Agenda Date: November 13, 2018

Vote Requirement: 4/5

Department or Agency Name(s): General Services

Staff Name and Phone Number:

Keith Lew: (707) 565-3193

Supervisorial District(s):

4th

Title: Cloverdale Veterans Building Solar Pool Heater Capital Project

Recommended Actions:

- A. Approve the addition of the Cloverdale Veterans Building Solar Pool Heater Capital Project in the FY 2018-19 Capital Projects Budget, at an estimated cost of \$94,000.
- B. Authorize the Director of General Services to enter into funding agreement with the City of Cloverdale and the Cloverdale Unified School District to jointly fund the procurement and installation of a solar thermal pool heater for the swimming pool at the Cloverdale Veterans Building, with a County fund contribution not to exceed \$50,000.
- C. Adopt a resolution authorizing adjustments to the 2018-19 Final Budget in the amount of \$44,000. (4/5ths vote)

Executive Summary:

The City of Cloverdale, and the Cloverdale Unified School District, desire to jointly fund with the County the procurement and installation of a solar thermal pool water heater at the Cloverdale Veterans Building. Swim programs are currently conducted at that location under a license agreement from the County of Sonoma. As the pool is not currently heated, the period in which the community can comfortably use the facility is limited. The swim season lasts from Memorial Day to Labor Day. The City and the School District desire to extend the swim program by improving the pool's usability through installation of a solar thermal pool heater.

The City and School District have proposed to enter into a funding agreement with the County to share the costs for the pool heater procurement and installation. This agreement would provide for the funding of the pool heater with fifty-three percent of the share from the County, twenty-seven percent from the City, and twenty percent from the School District.

Discussion:

The Cloverdale Veterans Building, located at 205 West First Street in Cloverdale, CA is a County-owned facility that includes a 100,000 gallon swimming pool located to the south of the building. While the building is maintained by the County and operated by Veterans volunteer staff, the pool is operated and managed by the City of Cloverdale through an annual agreement with the YMCA. A swim program has been in existence with the issuance of a May 2008 license agreement between the City and County. A new five year license agreement was issued in 2018 upon the expiration of the prior agreement.

The pool is a significant asset to the community. Swimming programs begin on Memorial Day and conclude on Labor Day as those dates fall within the season where the outdoor temperature and the pool temperature are acceptable for swimming. In 2018, that duration was 99 calendar days. The pool is currently unheated and water temperatures in mid spring and early fall are not comfortable for most program participants. This pool is the only public swimming pool facility in the vicinity. The closest other public swimming pool facility is located 18 miles south in Healdsburg, which is not convenient for Cloverdale School District or City sponsored swim programs.

The swim lessons have been offered at the Cloverdale facility since 1992 under Regional Parks. Programs were created in response to several drownings in the Russian River. Regional Parks "Let's Go Swimming / Vamos a Nadar" program has taught bilingual water-safety and swim lessons to more than 2,000 young people since 2004, including events in Cloverdale. The City of Cloverdale has been issued a license from the County starting in 2008. The local chapter of the YMCA, under license with the City of Cloverdale offers lessons to children and adults, emphasizing personal safety as well as for recreation purposes.

The Cloverdale Unified School District has a need for the pool as part of its instructional program. The School District structures its curriculum under California Department of Education standards, which include aquatic education in high school for physical education. Aquatic activities are specified in standards that include swimming, diving, lifeguarding, scuba diving and water polo, amongst other water related activities. Aquatic education is a two to three week unit for high school students. Given the limitations in class sizes, the number of students that can be instructed is limited, since the current swim season is currently limited by ambient temperatures. In order to accommodate educational and safety programs within the academic year, the extension of the swim season by heating the water to comfortable temperatures is needed. Installation of the pool heater would extend the swim season approximately by one month at the beginning and one month at the end, increasing availability of the pool by 67%.

The project would provide for the installation of a roof mounted solar thermal array, plumbing, pumps and a liquid pool cover to retain heat after sundown and to minimize the effects of evaporation when pool is not in use. Liquid pool covers are a safe, microscopically thin layer of alcohol that sits on top of the water in the pool, reducing evaporation and heat loss. Both liquid pool covers and solar thermal pool heaters are commercially available systems already in widespread use. An option for a more traditional thermal blanket pool cover will be included if proposals are favorable.

The City proposes to provide 27 percent of the project costs not to exceed \$25,000 while the School District providing 20 percent, not to exceed \$19,000 and the County would fund 53 percent of the cost,

not to exceed \$50,000. The heater system would be exclusively owned by the County, with no interest obtained by either the City or the School District.

In the event actual project procurement costs are projected to exceed the \$94,000 not to exceed amount under the proposed agreement, the County, City and School District would discuss any overages and determine whether to request further Board Action seeking additional funds or to cancel the project. Other financing options may be available for the project in order to help fit within funding constraints if needed.

On October 20, 2015, your Board received a report on the capital project funding needs at the Veterans Memorial Buildings. At the request of your Board, General Services and the Veterans Memorial Buildings Advisory Committee identified project priorities that would extend the useful life of the building and/or promoted the use of the building by the community. To date, the projects identified at that time have been completed or are nearing completion, with the exception of the Cotati Veterans memorial Building Kitchen, which was not performed due to low usage of the facility.

In order to help fund Veteran Buildings capital improvement projects, Measure L Transit Occupancy Tax (TOT) funds are allocated to General Services each year. In FY 2017-18 \$460,000 TOT funds were allocated, \$425,808 was used for Veteran Building improvement projects and \$34,192 went towards administrative costs to operate Veteran Buildings. The TOT funds helped fund the following projects:

- Santa Rosa Veteran Memorial Hall Seismic Upgrade and reroof construction (complete)
- Design of the Petaluma Veterans Memorial Hall Kitchen Renovation project (complete)
- Design of the Sonoma Veterans Memorial Hall Kitchen Renovation project (complete)
- Design of the Guerneville Veterans Memorial Hall heating, ventilation project (complete)

The FY 2018-19 budget also included \$460,000 of TOT funds for Veteran Building projects. Originally, General Services anticipated using the \$425,808 capital project funding as Hazard Mitigation Grant matching funds for seismic upgrades at the Petaluma Veterans Memorial Hall. However due to delays in the grant award and pressing needs at other Veteran Buildings, General Services has reprioritized TOT funds for the Fiscal Year. Here are the projects staff proposes to utilize TOT funds for this year:

- Sonoma Veterans Memorial Hall Kitchen Renovation project
- Guerneville Veterans Memorial Hall Air Conditioning project
- Cloverdale Veterans Memorial Hall Pool Heating project
- Design of the Petaluma Veterans Memorial Hall Seismic project

Even with the addition of three new Veteran Building improvement projects, there is still sufficient funding to use as matching funds for the design of the Petaluma Seismic project when the grant award comes through. Design is expected to take one year, and General Services plans to use FY 2019-20 TOT allocations to fund the construction phase of the project.

Consistent with the board direction in 2015, the Cloverdale Veterans Building solar thermal pool heater project is a priority because it promotes the use of the facility by the community. Expanding water safety programs is also critical to help mitigate risks to all water users, especially children and young people. This is a rare opportunity to share the cost burden with the City and the School District to install an asset of this magnitude and to provide a visible public benefit not seen in addressing deferred maintenance.

Prior Board Actions:

September 13, 2018: Authorized the Director of General Services to enter into a five year license agreement with the City of Cloverdale

August 28, 2018: Authorized award of construction contract for kitchen improvements at Sonoma Veterans Memorial Hall

October 20, 2015: Conducted a public hearing, adopted a Resolution and received report on capital project funding needs on Veteran’s Buildings

Strategic Plan Alignment Goal 1: Safe, Healthy, and Caring Community

Installation of a solar thermal pool water heater will significantly increase the opportunity to provide community swim programs, thereby improving water safety and encouraging healthy activities.

Fiscal Summary

Expenditures	FY 18-19 Adopted	FY 19-20 Projected	FY 20-21 Projected
Budgeted Expenses	50,000		
Additional Appropriation Requested	44,000		
Total Expenditures	94,000		

Funding Sources

General Fund/WA GF			
State/Federal			
Fees/Other	94,000		
Use of Fund Balance			
Contingencies			
Total Sources	94,000		

Narrative Explanation of Fiscal Impacts:

The total cost for the procurement and installation of the pool heater is \$94,000. The City, School District, and the County will enter into a funding agreement to share costs of the project, with the City and School District portion not-to-exceed \$44,000 and the County’s portion not-to-exceed \$50,000.

General Services Department proposes to redirect \$50,000 of Measure L TOT funds that were allocated in the FY18-19 Final Budget for this project.

Staffing Impacts

Position Title (Payroll Classification)	Monthly Salary Range (A – I Step)	Additions (Number)	Deletions (Number)

Narrative Explanation of Staffing Impacts (If Required):

Staffing impacts are minimal. Occasional inspection of lines will be performed at shut down and start up at the close of the swim season. These duties will be performed by existing staff who already evaluate the pool system.

Attachments:

Attachment 1: Resolution
Attachment 2: Agreement

Related Items “On File” with the Clerk of the Board:

--



County of Sonoma
State of California

Date: November 13, 2018

Item Number: _____
Resolution Number: _____

4/5 Vote Required

**Resolution Of The Board Of Supervisors Of The County Of Sonoma, State Of California,
Authorizing the Use of Funds For The General Services Department, In The Amount Of
\$50,000 and a Budget Adjustment For the General Services Department, in the Amount of
\$44,000.**

Whereas, the Board of Supervisors has adopted a Final Budget for the General Services portion of the Capital Projects Budget on June 14, 2018, and

Whereas, the Government Code allows for adjustments to the Final Budget during the Fiscal Year,

Now, Therefore, Be It Resolved that the General Services Department is authorized to transfer \$50,000 funds from Veterans Buildings Repairs Capital Improvement Project to the Cloverdale Veterans Building Solar Pool Heater Project,

Now, Therefore Be It Resolved that the County Auditor-Controller is hereby authorized and directed to make the following budgetary adjustments:

Financing Uses:

CAPITAL PROJECT FUND (22301): VETERANS BUILDING REPAIRS (40701000), CAPITAL
OUTLAY (54405) \$44,000

Financing Sources:

CAPITAL PROJECT FUND (22301): VETERANS BUILDING REPAIRS (40701000), CITY OF
CLOVERDALE (42616) \$25,000

CAPITAL PROJECT FUND (22301): VETERANS BUILDING REPAIRS (40701000), SPECIAL
DISTRICTS (42627) \$19,000

Resolution #

Date:

Page 2

Supervisors:

Gorin:

Rabbitt:

Zane:

Hopkins:

Gore:

Ayes:

Noes:

Absent:

Abstain:

So Ordered.

FUNDING AGREEMENT FOR PURCHASE AND INSTALLATION OF SOLAR HEATING SYSTEM FOR THE CLOVERDALE VETERANS POOL BETWEEN THE COUNTY OF SONOMA, CITY OF CLOVERDALE AND CLOVERDALE UNIFIED SCHOOL DISTRICT

This Agreement (“Agreement”), made and entered into on _____, 2018 (“Effective Date”), is by and between the COUNTY OF SONOMA, a political subdivision of the State of California (“County”), the CITY OF CLOVERDALE, a municipal corporation (“City”) and CLOVERDALE UNIFIED SCHOOL DISTRICT (“District”), a _____. The parties to this agreement are sometimes collectively referred to herein as the "Parties" and singularly, a "Party."

RECITALS

WHEREAS, THE County of Sonoma owns the facility known as the Cloverdale Veterans Memorial Building, located at 205 W. First Street, Cloverdale, California and such facility includes a swimming pool (“Pool Premises”) that the County maintains for the benefit of the general public; and

WHEREAS, THE District desires to conduct educational and safety programs, utilizing the Pool Premises, for the purpose of complying with the California Education Code by providing swimming education classes as part of the District’s curriculum, and

WHEREAS, THE City desires to conduct recreational and safety programs, utilizing the Pool Premises, for the benefit of the general public, and

WHEREAS, THE County and the City have an existing license agreement, as executed, dated July 1, 2018 (“License”) in place which, among other things, permits City to operate the swimming pool (“Pool”) located on the Pool Premises and which provides for the responsibilities of City and County in relation to the maintenance of the Pool and Pool Premises, and

WHEREAS, THE City permits the District to use the Pool without charge to the District, as permitted and conditioned by the License, and has agreed to continue to do so; and

WHEREAS THE City and the District desire to extend the swim season to accommodate public swim programs beyond the current annual period of operation through the installation of, a new solar pool heating system for the Pool, and.

WHEREAS THE Parties have agreed to share the costs of the design, equipment, and installation of such a solar heating system as set forth herein and the County has agreed to install the solar heating system.

NOW, THEREFORE, in consideration of the Pool Premises and of the agreements of the respective parties herein set forth, it is mutually agreed as follows:

AGREEMENT

1. Installation of Solar Heating Equipment. County has agreed to procure and install a solar pool heating system (Solar collectors, racks, pump and control system including a chemical

blanket system for the Pool) (*collectively*, “Equipment”) and City and District have agreed to contribute to the funding of the Equipment as set forth herein.

2. Allocation of Costs. The City shall reimburse the County for twenty-seven percent (27%) of the total cost for the procurement and installation, including all design/build costs (collectively referred to as the, “Total Cost”), of the Equipment, not to exceed Twenty-Five Thousand Dollars (\$25,000). The District shall reimburse County for twenty percent (20%) of the Total Cost of the Equipment, not to exceed Nineteen Thousand Dollars (\$19,000). The County’s share of the costs shall be fifty three percent (53%) of the Total Cost of the Equipment, not to exceed \$50,000. Additionally, County shall contribute all staff time necessary to prepare documents for competitive solicitation of a design build construction contract and to administer a contract entered into for the installation of the Equipment.
3. Solicitation of Design/Build Proposals. Upon execution of this Agreement, County shall solicit design/build proposals for the Equipment. The County intends to solicit proposals under a “best value” procurement where factors other than price will be considered in award.
4. Award of Contract. County shall notify City and District after responses to the solicitation have been received and City and District may review the responses before County makes a decision as to which, if any, proposal, it will accept. The County will consider any comments the City and the District may have but retains the sole right to award or not to award. If there is no acceptable proposal which is within \$94,000.00, County shall not award a contract for the Equipment unless and until the Parties agree in writing on how the costs exceeding \$94,000 will be allocated among the Parties. Absent agreement as to such excess costs, this Agreement shall terminate. If no acceptable proposal is received, County shall notify City and District of the fact and may then, at its option propose a re-solicitation for proposals which may include cost reduction measures such as value engineering or scope reduction. Absent agreement by both the City and the District to the terms of the re-solicitation, this Agreement shall terminate. If County awards a contract for a total price which is less than \$94,000, the total amount to be contributed by each Party shall be reduced in the same allocation as stated in Section 2, above.
5. Payment of City and District Shares to County. Upon awarding a contract for the Equipment, County shall notify City and District that a contract has been awarded and the total cost of the contract. Thereafter, County shall provide a copy of each invoice the County receives from the awarded contractor and City and District shall each reimburse County for their respective obligations as stated above of the amount of each invoice, up to the maximum amounts set forth in Section 2, above (or if applicable, as otherwise agreed pursuant to Section 4, above).
6. Installation of Equipment. County shall cause the Equipment to be installed, in accordance with manufacturer recommendations for the equipment. The contract for the Equipment shall provide that installation of the Equipment be done in a quality, workman-like manner to industry standard, and that all components of the Equipment be covered by industry-standard warranties. County makes no other warrants or guarantees regarding the Equipment, including as to its future performance, maintenance, or suitability. County shall use best efforts to minimize impacts to the Pool Premises during the installation of the Equipment. In the event the installation of said Equipment causes any direct or indirect

interference with the operation of the Pool Premises County shall take such action as is necessary to minimize and/or correct such interference.

7. Maintenance of Records and Final Accounting. County shall maintain complete records of the costs incurred for the Equipment. Within 60 days after completion of the installation and acceptance by County of the Equipment, County shall prepare an accounting (“Final Accounting”) of those costs and provide that Final Accounting to City and District. If the Final Accounting indicates that City and/or District have either under or over paid their share of the costs, as set forth in Sections 2 and 4, above, then County shall refund the excess amounts to any Party which overpaid and any Party which has underpaid shall make a final payment to County of additional amounts owed within 30 days.
8. Term. This Agreement shall terminate on the earlier of the following:
 - 8.1 Sixty days after the County has provided the Final Accounting to City and District.
 - 8.2 A determination by County after it has received responses to any solicitation for proposals that no acceptable proposals have been received and that the County will not be soliciting further proposals.
 - 8.3 One year from the date of this Agreement, if no contract for the Equipment has been entered into by County and the County is not, at that time, actively soliciting or reviewing proposals for the Equipment.
 - 8.4 Upon mutual agreement of the Parties.
9. Extent of Agreement. This Agreement is valid only to the extent of County’s jurisdiction as owner of the Pool Premises. Acquisition of any other necessary permits or entitlements for use are separate and unaffected by this Agreement. **NOTHING CONTAINED IN THIS AGREEMENT SHALL BE CONSTRUED AS A RELINQUISHMENT OF ANY RIGHTS NOW HELD BY COUNTY.**
10. The City and the District to Act in an Independent Capacity. The City, its officers, agents, and employees, and the District, its officers, agents and employees, shall act in an independent capacity and shall not represent themselves to be or be construed to be officers, agents, or employees of County.
11. Notice. Any notice required or permitted to be given under this Agreement shall be in writing. Delivery of such written notice shall be conclusively taken as sufficiently given forty-eight (48) hours after deposit in the United States Mail, registered or certified, return receipt requested, with the postage thereon fully prepaid, addressed as follows:

If to COUNTY: COUNTY OF SONOMA
General Services Department
Attn: Director
2300 County Center Drive, Suite A200
Santa Rosa, CA 95403

If to CITY: CITY OF CLOVERDALE
Attn:

If to DISTRICT CLOVERDALE UNIFIED SCHOOL DISTRICT

Attn:

_____.

Any Party may at any time change its address for notices by giving written notice of such change to the other Parties in the manner provided in this Section.

12. No Continuing Waiver. The waiver by any Party of any breach of any of the provisions of this Agreement shall not constitute a continuing waiver of any subsequent breach of the same, or of any other provision of this Agreement.
13. General Provisions.
 - 13.1 Time of Essence. Time is and shall be of the essence of this Agreement and of each and every provision contained in this Agreement.
 - 13.2 Merger; Amendments. This writing is intended both as the final expression of the Agreement between the Parties hereto with respect to the included terms and as a complete and exclusive statement of the terms of the Agreement, pursuant to Code of Civil Procedure Section 1856. This Agreement may be modified in writing only, signed by the parties in interest at the time of the modification, and this sentence may not be modified or waived by any oral agreement, whether executed or unexecuted.
 - 13.3 Binding Effect; Choice of Law. This Agreement shall be binding upon and inure to the benefit of the Parties, their personal representatives, successors, and assigns. This Agreement shall be governed by the laws of the State of California and any action to enforce the terms of this Agreement or for the breach thereof shall be brought and tried in the County of Sonoma.
 - 13.4 Amount Due Payable in U.S. Money. All sums payable under this Agreement must be paid in lawful money of the United States of America.
 - 13.5 No Third Party Beneficiaries. Nothing contained in this Agreement shall be construed to create and the parties do not intend to create any rights in third parties.
 - 13.6 Construction of Agreement; Severability. To the extent allowed by law, the provisions in this Agreement shall be construed and given effect in a manner that avoids any violation of statute, regulation, or law. The County, the City and the District agree that in the event any provision in this Agreement is held to be invalid or void by any court of competent jurisdiction, the invalidity of any such provision shall in no way affect any other provision in this Agreement. The City, the District, and the County acknowledge that they have each contributed to the making of this Agreement and that, in the event of a dispute over the interpretation of this Agreement, the language of the Agreement will not be construed against one party in favor of the other Party (ies). The City, the District and the County further acknowledge that they have each had an adequate opportunity to consult with counsel in the negotiation and preparation of this Agreement.

13.7 Relationship. The Parties intend by this Agreement to establish the relationship of County, City and District only, and do not intend to create a partnership, joint venture, joint enterprise, or any business relationship.

13.8 Captions. The captions in this Agreement are for convenience only and are not a part of this Agreement. The captions do not in any way limit or amplify the provisions hereof, and shall have no effect upon the construction or interpretation of any part hereof.

PARTIES HAVE CAREFULLY READ AND CONSIDERED THE TERMS AND CONDITIONS SET FORTH IN THIS AGREEMENT AND HEREBY AGREE THAT PARTIES SHALL BE BOUND BY ALL SAID TERMS AND CONDITIONS.

IN WITNESS WHEREOF, the Parties hereto have executed this Agreement as of the Effective Date.

CITY OF CLOVERDALE, a municipal corporation

By: _____

Print Name: _____

Title: _____

APPROVED AS TO FORM
FOR CITY:

Name:

Title:

CLOVERDALE UNIFIED SCHOOL DISTRICT

By: _____

Print Name: _____

Title: _____

APPROVED AS TO FORM
FOR DISTRICT:

Name:

Title:

COUNTY OF SONOMA, a political subdivision of the State of California

By: _____
Caroline Judy, Director
Department of General Services

APPROVED AS TO FORM
FOR COUNTY:

Jeremy M. Fonseca

Deputy County Counsel

DRAFT



County of Sonoma Agenda Item Summary Report

Clerk of the Board
575 Administration Drive
Santa Rosa, CA 95403

Agenda Item Number: 28
(This Section for use by Clerk of the Board Only.)

To: Board of Supervisors of Sonoma County

Board Agenda Date: November 13, 2018

Vote Requirement: Majority

Department or Agency Name(s): Department of Health Services

Staff Name and Phone Number:

Karen Holbrook, 565-4599

Supervisorial District(s):

Title: Dissolution of the Sonoma County Commission on AIDS

Recommended Actions:

Adopt a resolution dissolving the Sonoma County Commission on AIDS effective November 27, 2018; as supported by the Commission on AIDS to eliminate duplication with other organizations such as the HIV Service Providers Coalition.

Executive Summary:

California Department of Public Health allows, but does not require, a county to appoint an advisory board on human immunodeficiency virus infection and acquired immune deficiency syndrome (HIV/AIDS) treatment and prevention services. The Sonoma County Commission on AIDS, established by resolution of the Board of Supervisors (resolution number 87-1466), began meeting in 1987. The Commission's mission has historically included the following: 1) participation in collaborative planning addressing HIV/AIDS treatment and prevention service delivery for all segments of the community; 2) assisting in the development of appropriate and effective evaluation strategies; 3) encouraging and educating the public about HIV transmission and effective treatment and prevention strategies; and 4) encouraging community support of individuals with HIV infection and HIV/AIDS treatment and prevention services. Due to advances in HIV treatment; integration of HIV diagnosis, care, and other support services into mainstream care organizations and services; challenges with maintaining an effective advisory board; and duplication of efforts with the community's HIV Service Providers Coalition and other community organizations, the Department of Health Services recommends dissolving the Sonoma County Commission on AIDS.

Discussion:

The Commission on AIDS was established by resolution of the Board of Supervisors (resolution number 87-1466) on August 4, 1987 to address the AIDS epidemic in Sonoma County. Since that time, the landscape of the HIV/AIDS epidemic in Sonoma County has changed. Initially, advances in the treatment of HIV infections slowed progression to AIDS and spread of infection. After that initial period of rapid decline in newly diagnosed HIV cases in Sonoma County, then a period of stability, the number of new

cases is again declining. Improvements to the landscape of the HIV/AIDS epidemic since the inception of the Commission on AIDS include the following: 1) advances in the treatment of HIV infection such that with early diagnosis, proper treatment, and diligent self-care, many people with HIV infection can look forward to a normal lifespan managing a chronic illness; 2) integration of education on HIV diagnosis and care into mainstream medical education; 3) integration of HIV diagnosis and care into mainstream medical care; 4) established internal processes for clients of HIV care organizations to voice concerns about their care and services provided to them; 5) legislation mandating education about HIV/AIDS in public schools; 6) robust legal protections against discrimination based on HIV status; and 7) the presence of a vibrant HIV Services Providers Coalition.

Several years ago the Commission on AIDS members began discussing the ongoing need for the Commission. Relevant information introduced in those discussions included the following: a) no complaints or grievances about HIV care or services from County residents since 2010; b) diminished recruitment and retention of Commission on AIDS members; c) results from an informal survey of health leaders in other jurisdictions indicating a formal entity reporting to the County political leadership on HIV/AIDS is not standard across California; and d) the presence of other organizations and coalitions in Sonoma County that provide similar services more efficiently.

At the March 8, 2017 Commission on AIDS meeting, the Department of Health Services presented its recommendation that the Commission on AIDS be dissolved, and continued HIV work be done through the other organizations in Sonoma County including the HIV Service Providers Coalition and the Department of Health Services. The Commission on AIDS approved the recommendation to dissolve.

HIV Prevention and Care coordination and collaboration on how to best serve Sonoma County residents will be continued through the HIV Service Providers Coalition. Membership includes Center Point/Drug Abuse Alternatives Center, Face to Face, Food for Thought, Kaiser of Santa Rosa, North Coast Area AIDS Education and Training Center, Santa Rosa Community Health Centers, Sonoma County Department of Health Services, Sonoma County Indian Health Project, and West County Health Center. Several representatives from the Coalition will be present during the World AIDS Day gold resolution presentation on November 13th. This coalition was established in 2009 to collaborate on HIV prevention and care services and strategies to find people at risk and keep people in medical care; promote public awareness for HIV; disseminate best practices on HIV medical care; increase access to social services; facilitate linkages to care for HIV positive clients; identify and mitigate gaps in care; and coordinate and plan educational events.

Prior Board Actions:

On August 4, 1987 the Commission on AIDS was established by resolution of the Board of Supervisors (resolution number 87-1466).

Strategic Plan Alignment Not Applicable

Fiscal Summary

Expenditures	FY 18-19 Adopted	FY 19-20 Projected	FY 20-21 Projected
Budgeted Expenses			
Additional Appropriation Requested			
Total Expenditures	0	0	0
Funding Sources			
General Fund/WA GF			
State/Federal			
Fees/Other			
Use of Fund Balance			
Contingencies			
Total Sources	0	0	0

Narrative Explanation of Fiscal Impacts:

There are no fiscal impacts associated with this item.

Staffing Impacts

Position Title (Payroll Classification)	Monthly Salary Range (A – I Step)	Additions (Number)	Deletions (Number)

Narrative Explanation of Staffing Impacts (If Required):

N/A

Attachments:

Resolution

Related Items "On File" with the Clerk of the Board:

None



County of Sonoma

State of California

Date: November 13, 2018

Item Number: _____
Resolution Number: _____

4/5 Vote Required

Resolution of the Board of Supervisors of the County of Sonoma, State of California, Dissolving the Sonoma County Commission on AIDS Effective November 27, 2018

Whereas, the Sonoma County Commission on AIDS was established by the Board of Supervisors in 1987 to address the AIDS epidemic in Sonoma County;

Whereas, the HIV/AIDS epidemic landscape has changed and improved since the Sonoma County Commission on AIDS was established;

Whereas, there have been advances in the treatment of HIV infection such that with early diagnosis, proper treatment and diligent self-care, many people with HIV infection can look forward to a normal lifespan managing a chronic illness; and

Whereas, dissolving the Sonoma County Commission on AIDS will reduce staff time and enable other community organizations and coalitions to more efficiently monitor the epidemic and plan and implement appropriate responses.

Now, Therefore, Be It Resolved that the Board of Supervisors does hereby dissolve the Sonoma County Commission on AIDS effective November 27, 2018.

Supervisors:

Gorin:

Rabbitt:

Zane:

Hopkins:

Gore:

Ayes:

Noes:

Absent:

Abstain:

So Ordered.



County of Sonoma Agenda Item Summary Report

Clerk of the Board
575 Administration Drive
Santa Rosa, CA 95403

Agenda Item Number: 29
(This Section for use by Clerk of the Board Only.)

To: Board of Supervisors of Sonoma County

Board Agenda Date: November 13, 2018

Vote Requirement: 4/5

Department or Agency Name(s): Department of Health Services

Staff Name and Phone Number:

Angie Dillon-Shore, 565-6627

Supervisorial District(s):

Title: First 5 Sonoma County Commission Quality Rating and Improvement System Agreements

Recommended Actions:

Authorize the Director of Health Services to execute a memorandum of understanding with the Sonoma County Office of Education for the County of Sonoma to receive revenue, which will support First 5 Sonoma County efforts to improve the quality of education provided in early education sites in Sonoma County, in the amount of \$364,980 through September 30, 2019.

Authorize the Director of Health Services to execute an agreement with Community Child Care Council of Sonoma County for quality rating and improvement system services, which serve to improve the quality of education provided in early education sites in Sonoma County, for the period July 1, 2018 to September 30, 2019 in an amount not-to-exceed \$303,763.

Adopt a resolution adjusting the fiscal year 2018-2019 final budget by increasing revenues by 323,777 and expenditures in the Department of Health Services by \$287,560 to reflect receipt of Sonoma County Office of Education grant revenue and associated expenditures. (4/5 vote required)

Executive Summary:

This item requests approval of a memorandum of understanding for the County of Sonoma to receive revenue from the Sonoma County Office of Education and a services agreement with Community Child Care Council of Sonoma County. Both agreements support the First 5 Sonoma County quality rating and improvement system, a systemic approach to assess, improve, and communicate the level of quality in early care and education programs. The First 5 Sonoma County Commission approved the proposed agreement with Community Child Care Council of Sonoma County at the September 24, 2018 Commission meeting and the proposed agreement with Sonoma County Office of Education at the October 22, 2018 Commission meeting.

This item also requests approval of a resolution adjusting the fiscal year 2018-2019 budget to reflect receipt of Sonoma County Office of Education grant revenue and associated expenditures.

Discussion:

The overarching goal of the 2011-2020 First 5 Sonoma County Strategic Plan is to have *all children enter kindergarten ready to succeed*. The Strategic Plan goal areas are: 1) ensure the health and healthy development of children, 2) ensure families are supported and nurturing, 3) ensure that early care and education is high quality, 4) increase integration of systems to better serve children and families, and 5) engage the entire community to support achievement of First 5 Sonoma County goals. The agreements for which approval is being requested primarily support goal area 3.

Since 2010 First 5 Sonoma has focused on ensuring that early care and education is of the highest quality. Research has shown that children who have experienced quality preschool are more likely to demonstrate academic and social-emotional competence and will more likely enter kindergarten ready to succeed. Providing quality preschool can help close the achievement gap. Sonoma County's unique quality improvement programs include Road to the Early Achievement and Development of Youth, Value in Preschool, The Consultation Project, and Teachers Acquiring Language Learner Knowledge, all supported by First 5 Sonoma County. Both the California Department of Education and First 5 California's funding priorities are now aligned with efforts supported for many years in the community around quality improvement in early education by First 5 Sonoma County.

A quality rating and improvement system is a systemic approach to assess, improve, and communicate the level of quality in early care and education programs. Similar to rating systems for restaurants and hotels, quality rating and improvement systems award quality ratings to early care and education programs that meet a set of defined program standards. In efforts to support *Goal 3 – ensure that early care and education is high quality*, First 5 Sonoma County has selected *Quality Counts* as their quality rating and improvement system. Since 2014, 109 sites have participated in *Quality Counts*, 67 have been rated, and over \$915,000 has been distributed in awards and incentives for participation. Participating sites also received coaching, professional development, and official observations and assessments; and approximately 1,205 Sonoma County preschoolers have benefitted from this increase in quality early education. *Quality Counts* will add new participants each year, with an estimated 150 sites receiving ratings by 2020.

Quality Counts was selected to receive California Department of Education Quality Rating and Improvement System Block Grants totaling \$1,715,677 since FY 14-15, in addition to the proposed grant of \$364,980, which will support efforts during school years 2018-2019 and 2019-2020. Funds from the California Department of Education have decreased each year as more counties develop their quality rating and improvement systems and apply for funds. Sonoma County Office of Education, as the Local Education Agency for the Sonoma County Quality Rating and Improvement System Consortium, will receive grant funds from the California Department of Education and pass them through to First 5 Sonoma County as the Lead Agency to oversee the rating process and provide administration as defined in the proposed memorandum of understanding. The Commission approved the memorandum of understanding with Sonoma County Office of Education at its September 24, 2018 meeting. Grant funds will be used to fund the proposed agreement with Community Child Care Council, First 5 Sonoma County staff, and additional, smaller quality rating and improvement system-related agreements to be executed under department delegated authority.

Community Child Care Council of Sonoma County, through the proposed agreement, will work to improve quality ratings for all participating early education sites in *Quality Counts*. Community Child Care Council has hired six experienced early learning coaches to work with sites across Sonoma County,

providing one-on-one coaching and technical assistance. Participant surveys demonstrate that providers find this support to be invaluable for their staff to incorporate changes to ongoing practices. Community Child Care Council will utilize Early Learning Coaches and a Master Coach to work with state preschool providers. They will also administer approximately \$170,000 in Tier 4 and 5 awards to state preschools participating in *Quality Counts*. The Commission approved the agreement with Community Child Care Council at its September 24, 2018 meeting. The Purchasing Agent approved a single source waiver request for this agreement on October 15, 2018.

Sonoma County First 5 Commission is an agency of the County of Sonoma, which by law has independent authority over its strategic plan and local trust fund. As directed by the Board of Supervisors in the Commission's enabling ordinance, the Commission follows established County administrative procedures for processing its contracts through its administrative agent, the Department of Health Services.

Prior Board Actions:

On March 20, 2018, the Board approved 1) a memorandum of understanding with the Sonoma County Office of Education for the County of Sonoma to receive revenue to support the First 5 Sonoma County Quality Rating and Improvement System, *Quality Counts*, in the amount of \$365,066 through September 30, 2018 and 2) an agreement with Community Child Care Council of Sonoma County for *Quality Counts* services for the period of July 1, 2017 through September 30, 2018 for a total not-to-exceed amount of \$290,203.

Strategic Plan Alignment Goal 1: Safe, Healthy, and Caring Community

The Sonoma County Quality Rating and Improvement System, *Quality Counts*, aligns with the County's Strategic Plan Goal Area 1 and First 5 Sonoma County Commission Strategic Plan Goal 3 (Ensure that Early Care and Education is High Quality) by working to ensure that all children enter kindergarten ready to succeed.

Fiscal Summary

Expenditures	FY 18-19 Adopted	FY 19-20 Projected	FY 20-21 Projected
Budgeted Expenses	36,217	41,203	0
Additional Appropriation Requested	287,560		
Total Expenditures	323,777	41,203	0
Funding Sources			
General Fund/WA GF			
State/Federal	323,777	41,203	
Fees/Other			0
Use of Fund Balance			
Contingencies			
Total Sources	323,777	41,203	0

Narrative Explanation of Fiscal Impacts:

Additional appropriations of \$287,560 will be added to the FY 18-19 budget via resolution. Grant-funded expenditures of \$36,217 for First 5 Sonoma County staff are included in the FY 18-19 budget. Grant-funded expenditures and revenue of \$41,203 will be included in the FY 19-20 budget.

The Sonoma County Office of Education grant will provide revenue of \$323,777 in FY 18-19 and \$41,203 in FY 19-20, for a total of \$364,980. Per the terms of the grant, any balances remaining at the end of FY 18-19 shall automatically be carried forward to FY 19-20.

A summary of grant-funded expenditures is provided in the table below.

Description	FY 18-19 (\$)	FY 19-20 (\$)	Total (\$)
Community Child Care Council agreement	262,560	41,203	303,763
First 5 Sonoma County staff	36,217	0	36,217
Additional <i>Quality Counts</i> -related services agreements	25,000	0	25,000
Total (\$)	323,777	41,203	364,980

Staffing Impacts

Position Title (Payroll Classification)	Monthly Salary Range (A – I Step)	Additions (Number)	Deletions (Number)

Narrative Explanation of Staffing Impacts (If Required):

N/A

Attachments:

Memorandum of understanding with Sonoma County Office of Education, services agreement with Community Child Care Council of Sonoma County, budgetary adjustment resolution

Related Items "On File" with the Clerk of the Board:

None

Memorandum of Understanding:
CSPP Quality Rating Improvement System Block Grant Year 5
July 1, 2018 – September 30, 2019
(FY 2018-19/FY 2019-20)

This memorandum of understanding (MOU) is by and between **Sonoma County Office of Education, Child Care Planning Council**, hereinafter referred to as “SCOE”, and **The County of Sonoma** on behalf of First 5 Sonoma County Commission, hereinafter referred to as “First 5”, for performance of services under the **CSPP Quality Rating Improvement System Block Grant** through the California Department of Education, Early Education and Support Division.

The purpose of this MOU is to establish the roles and responsibilities of the parties in the administration of the CSPP QRIS Block Grant funding.

I. BACKGROUND

The Sonoma County Quality Rating Improvement System (QRIS) Consortium was awarded \$364,980.00 of Proposition 98 funding to support local early learning and increase the number of low-income children in high quality state preschool programs, with SCOE/CCPC serving as the Fiscal Agent, and First 5 as the Lead Agency. The funding is for the purpose of allowing local consortia to give local QRIS Block Grants (awards) to California State Preschool Program (CSPP) sites that have been rated at a quality level of Tier 4 or higher, to raise the quality of CSPPs not yet at Tier 4, and allows use of up to twenty percent (20%) of the funds for conducting assessments of programs and providing or supporting access projects.

II. CSPP QUALITY RATING IMPROVEMENT SYSTEM BLOCK GRANT COMPONENTS

CSPP Quality Rating Improvement System Block Grant components include:

- Standards and Assessments
- Technical Assistance, Coaching and Quality Improvement
- Training and Professional Development
- Support, Incentives and Awards
- QRIS Rating

These components have been designed by the Sonoma County QRIS Consortium, and will be implemented by Consortium members and/or additional subcontractors.

III. TERMS OF THE MOU

The Sonoma County QRIS Consortium will provide direction and guidance to all Block Grant partners on the design and implementation of the Block Grant services. The following roles and responsibilities have been delineated by the Sonoma County QRIS Consortium.

1. **SCOE/CCPC's Roles and Responsibilities:**

- a. Serve as Fiscal Agent, receiving and disbursing funds from CDE, and submitting all required reports to CDE.
- b. Provide the external reliable assessments for this QRIS Block Grant through the Gateway to Quality Program administered by SCOE's Child Care Planning Council of Sonoma County (CCPC) and, therefore, contract with First 5 in the amount of \$25,000 for this purpose.

2. **First 5 Sonoma County's Roles and Responsibilities**

- a. Serve as Lead Agency, administering and allocating funding for the remaining QRIS Block Grant program components, as described in the approved CSPP QRIS Block Grant RFA response, which by reference is made part of this Agreement.
- b. Serve as Consortium Lead (Convener)
- c. Manage Portfolio TA & Rating, including Self-Assessment distribution & collection
- d. Issue stipends for participation & completion, and awards
- e. Provide QRIS Database management
- f. Issue and monitor funding contracts for Block Grant component activities
- g. Provide contract for external reliable assessments for this QRIS Block Grant through the Quality Counts Assessments program administered by SCOE's Child Care Planning Council of Sonoma County (CCPC).
- h. Submit financial activity reports to SCOE per the schedule below, and any program activity reports as required by CDE.

CDE Fiscal Reporting Period	Financial Activity Report Due to SCOE	Due to CDE
July 1, 2018 – February 28, 2019	3/16/2019	3/28/2019
March 1, 2019 – September 30, 2019	11/30/2019	12/31/2019

SCOE CONTACT: Susy Marrón
 CCPC/SCOE
 5340 Skylane Blvd.
 Santa Rosa, CA 95401
 (707) 524-2639
smarron@scoe.org

First 5 CONTACT: Leah Benz
 First 5 Sonoma County
 490 Mendocino Ave, Suite 203
 Santa Rosa, CA 95401
 (707) 565-6614
leah.benz@sonoma-county.org

IV. PAYMENT

SCOE will pay to First 5 \$328,482 when 90% funding is received by CDE. SCOE will pay First 5 the remaining \$36,498, if expended, when the final 10% distribution of funds is made by CDE.

Any balances remaining at the end of any given fiscal year shall automatically be carried forward to the subsequent fiscal year. Under no circumstances will SCOE be responsible for more than the \$364,980 agreed upon.

First 5 Shall use the funds received from SCOE solely for the purposes outlined in this MOU.

V. TERM OF MOU

The term of this MOU shall be from July 1, 2018 through September 30, 2019.

VI. CONFIDENTIALITY

Both parties agree to maintain the confidentiality of all client information in accordance with applicable state and federal laws and regulations.

VII. DISPUTE RESOLUTION

If any conflicts or disputes arise between the two parties involved, staff shall meet in a timely manner to resolve the conflict or dispute. It is acknowledged by both parties that the purpose of such meeting is to come to a resolution that is in the best interest of both parties. If the parties are unable to resolve the dispute through such a meeting, then they agree to submit the dispute to non-binding mediation in order to try to do so with the assistance of a mediator.

VIII. INDEMNIFICATION

Each party shall indemnify, defend, protect, hold harmless, and release the other, its officers, agents, and employees, from and against any and all claims, loss, proceedings, damages, causes of action, liability, costs, or expense (including attorney's fees and witness costs) arising from or in connection with, or caused by any act, omission, or negligence of such indemnifying party. This indemnification obligation shall not be limited in any way by any limitations on the amount or type of damages or compensation payable to or for the indemnifying party under workers' compensation, disability benefit, or other employee benefit statutes.

IX. MERGER

This writing is intended both as the final expression of the MOU between the parties hereto with respect to the included terms and as a complete and exclusive statement of the terms of the MOU. No modification of this MOU shall be effective unless and until such modification is evidenced by a writing signed by both parties.

X. SIGNATURES

IN WITNESS WHEREOF, the parties hereto have executed this MOU as of _____ (effective date).

SCOE Deputy Superintendent

DATE: _____

Director of Health Services, Sonoma County

DATE: _____

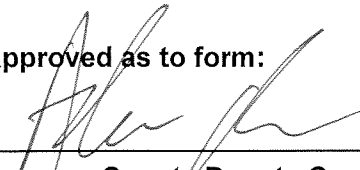
Approved as to form:

Sonoma County Deputy County Counsel

DATE: 9/25/18

Executive Director, First 5 Sonoma County Commission

DATE: _____

COUNTY OF SONOMA
AGREEMENT FOR SERVICES

This agreement ("Agreement"), dated as of _____, 2018 ("Effective Date"), is by and between the County of Sonoma, a political subdivision of the State of California (hereinafter "County"), on behalf of First 5 Sonoma County Commission (hereinafter "Commission") and Community Child Care Council of Sonoma County (hereinafter "Contractor").

RECITALS

WHEREAS, Contractor represents that it is a duly qualified, early-childhood resource agency, experienced in the provision of early-childhood education and related services;

WHEREAS, Commission is an agency of the County with independent authority over the First 5 Sonoma County Commission Strategic Plan and the local special revenue fund; and use of the term "County" in this Agreement necessarily includes the Commission;

WHEREAS, Commission desires to allocate California Department of Education CSPP Round 5 resources to administer Tier 4 and 5 Rating Awards and provide coaching services to California State Preschool Programs in accordance with the program goals and objectives outlined in the First 5 Sonoma County Commission Strategic Plan; and

WHEREAS, in the judgment of Commission, it is necessary and desirable to employ the services of Contractor for the above services.

NOW, THEREFORE, in consideration of the foregoing recitals and the mutual covenants contained herein, the parties hereto agree as follows:

AGREEMENT

1. Scope of Services

1.1. Contractor's Specified Services

Contractor shall perform the services described in Exhibit A (Scope of Work), attached hereto and incorporated herein by this reference (hereinafter "Exhibit A"), within the times or by the dates provided for in Exhibit A and pursuant to Article 7 (Prosecution of Work). In the event of a conflict between the body of this Agreement and Exhibit A, the provisions in the body of this Agreement shall control.

1.2. Cooperation With County

Contractor shall cooperate with County and County staff in the performance of all work hereunder.

1.3. Performance Standard

Contractor shall perform all work hereunder in a manner consistent with the level of competency and standard of care normally observed by a person practicing in Contractor's profession. County has relied upon the professional ability and training of Contractor as a material inducement to enter into this Agreement. Contractor hereby agrees to provide all services under this Agreement in accordance with generally accepted professional practices and standards of care, as well as the requirements of applicable federal, state, and local laws, it being

understood that acceptance of Contractor's work by County shall not operate as a waiver or release. If County determines that any of Contractor's work is not in accordance with such level of competency and standard of care, County, in its sole discretion, shall have the right to do any or all of the following: (a) require Contractor to meet with County to review the quality of the work and resolve matters of concern; (b) require Contractor to repeat the work at no additional charge until it is satisfactory; (c) terminate this Agreement pursuant to the provisions of Article 4 (Termination); or (d) pursue any and all other remedies at law or in equity.

1.4. Assigned Personnel

- a. Contractor shall assign only competent personnel to perform work hereunder. In the event that at any time County, in its sole discretion, desires the removal of any person or persons assigned by Contractor to perform work hereunder, Contractor shall remove such person or persons immediately upon receiving written notice from County.
- b. Any and all persons identified in this Agreement or any exhibit hereto as the project manager, project team, or other professional performing work hereunder are deemed by County to be key personnel whose services were a material inducement to County to enter into this Agreement, and without whose services County would not have entered into this Agreement. Contractor shall not remove, replace, substitute, or otherwise change any key personnel without the prior written consent of County.
- c. In the event that any of Contractor's personnel assigned to perform services under this Agreement become unavailable due to resignation, sickness, or other factors outside of Contractor's control, Contractor shall be responsible for timely provision of adequately qualified replacements.

1.5. Contract Exhibits

This Agreement includes the following exhibits, which are hereby incorporated by reference as though fully set forth herein:

- Exhibit A. Scope of Work
- Exhibit B. Budget
- Exhibit C. Insurance Requirements

2. Payment

For all services and incidental costs required hereunder, Contractor shall be paid in accordance with the following terms:

2.1. Payment for Services

Contractor shall be paid on a time-and-material/expense basis in accordance with the budget set forth in Exhibit B (Budget), attached hereto and incorporated herein by this reference (hereinafter "Exhibit B"). Should documented costs and expenses total less than the authorized annual total (on a fiscal-year basis), at the sole discretion of County, the unexpended balance shall carry forward to the next fiscal year until the expiration of this Agreement. Any balance carried forward may be offset by County, at its sole discretion, against the amount due for the next fiscal year under the Agreement. Contractor shall submit its bills in arrears on a monthly basis in a form approved by County's Auditor and the Head of County department receiving the

services. The bills shall show or include: (i) the task(s) performed, (ii) the time in quarter hours devoted to the task(s), (iii) the hourly rate(s) of the person(s) performing the task(s), and (iv) copies of receipts for reimbursable materials/expenses, if any. Expenses not expressly authorized by the Agreement shall not be reimbursed.

Unless otherwise noted in this Agreement, payments shall be made within the normal course of County business after presentation of an invoice in a form approved by County for services performed. Payments shall be made only upon the satisfactory completion of the services as determined by County.

2.2. Maximum Payment Obligation

In no event shall County be obligated to pay Contractor more than the total sum of \$303,763 under the terms and conditions of this Agreement.

2.3. California Franchise Tax Withhold

Pursuant to California Revenue and Taxation Code (R&TC) Section 18662, County shall withhold seven percent of the income paid to Contractor for services performed within the State of California under this Agreement for payment and reporting to the California Franchise Tax Board if Contractor does not qualify as: (1) a corporation with its principal place of business in California, (2) an LLC or partnership with a permanent place of business in California, (3) a corporation/LLC or partnership qualified to do business in California by the Secretary of State, or (4) an individual with a permanent residence in the State of California.

If Contractor does not qualify, County requires that a completed and signed California Form 587 be provided by Contractor in order for payments to be made. If Contractor is qualified, then County requires a completed California Form 590. California Forms 587 and 590 remain valid for the duration of the Agreement provided there is no material change in facts. By signing either form, Contractor agrees to promptly notify County of any changes in the facts. Forms should be sent to County pursuant to Article 12 (Method and Place of Giving Notice, Submitting Bills, and Making Payments). To reduce the amount withheld, Contractor has the option to provide County with either a full or partial waiver from the State of California.

2.4. Overpayment

If County overpays Contractor for any reason, Contractor agrees to return the amount of such overpayment to County, or at County's option, permit County to offset the amount of such overpayment against future payments owed to Contractor under this Agreement or any other agreement.

2.5. Disallowance of Payment

In the event that Contractor claims or receives payment from County for a service, reimbursement for which is later disallowed by County, State of California, or the United States Government, then Contractor shall promptly refund the disallowed amount to County upon request, or at its option, County may offset the amount disallowed from any payment due or that becomes due to Contractor under this Agreement or any other agreement.

2.6. Budget Line Amendments

County Department of Health Services Director is authorized to approve and execute a "Budget Revision Form", which revises program funds in the line items set forth in the Program

Budget Summary, so long as changes do not result in an increase in County's maximum payment obligation as set forth in Article 2 (Payment) of this Agreement.

2.7. Federal Funding

This Section 2.7 is applicable if all or part of this Agreement will be paid with federal awards.

2.7.1. Required Information

As a pass-through entity, County is required to provide certain information regarding federal award(s) to Contractor as a subrecipient. In signing this Agreement, Contractor acknowledges receipt of the following information regarding federal award(s) that will be used to pay this Agreement:

- a. CFDA Number: n/a
- b. CFDA Title: n/a
- c. Federal Agency: n/a
- d. Award Name: n/a
- e. Federal Award(s) Amount: n/a

2.7.2. Title 2 Code of Federal Regulations Part 200

As a subrecipient of federal awards, Contractor is subject to the provisions of Title 2 Code of Federal Regulations Part 200 Uniform Administrative Requirements, Cost Principles, and Audit Requirements for Federal Awards (hereinafter "2 CFR Part 200"). In signing this Agreement, Contractor acknowledges that it understands and will comply with the provisions of 2 CFR Part 200. One provision of 2 CFR Part 200 requires a subrecipient that expends \$750,000 in federal awards during its fiscal year to have an audit performed in accordance with 2 CFR Part 200. If such an audit is required, Contractor agrees to provide County with a copy of the audit report within 9 months of Contractor's fiscal year-end. Questions regarding 2 CFR Part 200 can be directed to County's Auditor-Controller-Treasurer-Tax Collector's Office – General Accounting Division.

2.7.3. Audits

Contractor agrees that all expenditures of state and federal funds furnished to Contractor pursuant to this Agreement are subject to audit by County, state agencies, and/or federal agencies. Contractor warrants that it shall comply with the audit requirements as set forth in 2 CFR Part 200. County agrees to provide 14-days notice of intent of County to audit Contractor. Contractors subject to the Single Audit Act of 1984 and Single Audit Act Amendments of 1996 shall annually submit an independent audit conforming to 2 CFR Part 200, which applies to non-profit organizations.

2.7.4. Copy of Audit

Contractor agrees that a copy of audits performed shall be submitted to County no later than 30 days after completion of the audit report, or no later than 9 months after the end of Contractor's fiscal year, whichever comes first. The Contractor's agreement(s) with audit firms shall have a clause to permit access by County, state agencies, and/or federal agencies to the working papers of the external independent auditor.

2.7.5. Retention of Audit Report

Contractor agrees that audit reports and work papers shall be retained for a minimum of 7 years from the date of the audit report, unless the auditor is notified in writing by County, a state agency, and/or a federal agency to extend the retention period.

2.7.6. Repayment

Contractor is responsible for the repayment of all audit exceptions and disallowances taken by County, state agencies, and/or federal agencies related to services provided by Contractor under this Agreement. Unallowable costs that have been claimed and reimbursed will be refunded to the program that reimbursed the unallowable costs either by cash refund or by offset to subsequent claims.

3. Term of Agreement

The term of this Agreement shall be from July 1, 2018 to September 30, 2019 unless terminated earlier in accordance with the provisions of Article 4 (Termination).

4. Termination

4.1. Termination Without Cause

Notwithstanding any other provision of this Agreement, at any time and without cause, County shall have the right, in its sole discretion, to terminate this Agreement by giving 5 days advance written notice to Contractor.

4.2. Termination for Cause

Notwithstanding any other provision of this Agreement, should Contractor fail to perform any of its obligations hereunder within the time and in the manner herein provided or otherwise violate any of the terms of this Agreement, County may immediately terminate this Agreement by giving Contractor written notice of such termination, stating the reason for termination.

4.3. Delivery of Work Product and Final Payment Upon Termination

In the event of termination, Contractor, within 14 days following the date of termination, shall deliver to County all materials and work product subject to Section 9.11 (Ownership and Disclosure of Work Product) and all reports, original drawings, graphics, plans, studies, and other data or documents, in whatever form or format, assembled or prepared by Contractor or Contractor's subcontractors, consultants, and other agents in connection with this Agreement, and shall submit to County an invoice showing the services performed, hours worked, and copies of receipts for reimbursable expenses up to the date of termination.

4.4. Payment Upon Termination

Upon termination of this Agreement by County, Contractor shall be entitled to receive, as full payment for all services satisfactorily rendered and reimbursable expenses properly incurred hereunder, an amount which bears the same ratio to the total payment specified in the Agreement as the services satisfactorily rendered hereunder by Contractor bear to the total services otherwise required to be performed for such total payment; provided, however, that if services which have been satisfactorily rendered are to be paid on a per-hour or per-day basis, Contractor shall be entitled to receive as full payment an amount equal to the number of hours or days actually worked prior to the termination times the applicable hourly or daily rate; and further

provided, however, that if County terminates the Agreement for cause pursuant to Section 4.2 (Termination for Cause), County shall deduct from such amount the amount of damage, if any, sustained by County by virtue of the breach of the Agreement by Contractor.

4.5. Authority to Terminate

The Board of Supervisors has the authority to terminate this Agreement on behalf of County. In addition, the Purchasing Agent or Department of Health Services' Head, in consultation with County Counsel, shall have the authority to terminate this Agreement on behalf of County.

4.6. Obligations After Termination

The following shall remain in full force and effect after termination of this Agreement: (1) Section 2.7 (Federal Funding), (2) Article 5 (Indemnification), (3) Section 9.5 (Records Maintenance), (4) Section 9.5.1 (Right to Audit, Inspect, and Copy Records), (5) Section 9.15 (Confidentiality), and (6) Section 13.5 (Applicable Law and Forum).

4.7. Change in Funding

Contractor understands and agrees that County shall have the right to terminate this Agreement immediately upon written notice to Contractor in the event that (1) any state and/or federal agency and/or other funder(s) reduces, withholds, or terminates funding which County anticipated using to pay Contractor for services provided under this Agreement, or (2) County has exhausted all funds legally available for payments due under this Agreement.

5. Indemnification

Contractor agrees to accept all responsibility for loss or damage to any person or entity, including County, and to indemnify, hold harmless, and release County, its officers, agents, and employees from and against any actions, claims, damages, liabilities, disabilities, or expenses that may be asserted by any person or entity, including Contractor, that arise out of, pertain to, or relate to Contractor's or its agents', employees', contractors', subcontractors', or invitees' performance or obligations under this Agreement. Contractor agrees to provide a complete defense for any claim or action brought against County based upon a claim relating to such Contractor's or its agents', employees', contractors', subcontractors', or invitees' performance or obligations under this Agreement. Contractor's obligations under this Article apply whether or not there is concurrent or contributory negligence on County's part, but to the extent required by law, excluding liability due to County's conduct. County shall have the right to select its legal counsel at Contractor's expense, subject to Contractor's approval, which shall not be unreasonably withheld. This indemnification obligation is not limited in any way by any limitation on the amount or type of damages or compensation payable to or for Contractor or its agents under workers' compensation acts, disability benefits acts, or other employee benefit acts.

6. Insurance

With respect to performance of work under this Agreement, Contractor shall maintain and shall require all of its subcontractors, consultants, and other agents to maintain insurance as described in Exhibit C (Insurance Requirements), which is attached hereto and incorporated herein by this reference (hereinafter "Exhibit C").

7. Prosecution of Work

The execution of this Agreement shall constitute Contractor's authority to proceed immediately with the performance of this Agreement. Performance of the services hereunder shall be completed within the time required herein, provided, however, that if the performance is delayed by earthquake, flood, high water, or other Act of God, or by strike, lockout, or similar labor disturbances, the time for Contractor's performance of this Agreement shall be extended by a number of days equal to the number of days Contractor has been delayed.

8. Extra or Changed Work

Extra or changed work or other changes to the Agreement may be authorized only by written amendment to this Agreement, signed by both parties. Changes which do not exceed the delegated signature authority of the Department may be executed by the Department Head in a form approved by County Counsel. The Board of Supervisors or Purchasing Agent must authorize all other extra or changed work which exceeds the delegated signature authority of the Department Head. The parties expressly recognize that, pursuant to Sonoma County Code Section 1-11, County personnel are without authorization to order extra or changed work or waive Agreement requirements. Failure of Contractor to secure such written authorization for extra or changed work shall constitute a waiver of any and all right to adjustment in the Agreement price or Agreement time due to such unauthorized work and thereafter Contractor shall be entitled to no compensation whatsoever for the performance of such work. Contractor further expressly waives any and all right or remedy by way of restitution and quantum meruit for any and all extra work performed without such express and prior written authorization of the County.

9. Representations of Contractor

9.1. Standard of Care

County has relied upon the professional ability and training of Contractor as a material inducement to enter into this Agreement. Contractor hereby agrees that all its work will be performed and that its operations shall be conducted in accordance with generally accepted and applicable professional practices and standards as well as the requirements of applicable federal, state, and local laws, it being understood that acceptance of Contractor's work by County shall not operate as a waiver or release.

9.2. Status of Contractor

The parties intend that Contractor, in performing the services specified herein, shall act as an independent contractor and shall control the work and the manner in which it is performed. Contractor is not to be considered an agent or employee of County and is not entitled to participate in any pension plan, workers' compensation plan, insurance, bonus, or similar benefits that County provides its employees. In the event County exercises its right to terminate this Agreement pursuant to Article 4 (Termination), Contractor expressly agrees that it shall have no recourse or right of appeal under rules, regulations, ordinances, or laws applicable to employees.

9.3. No Suspension or Debarment

Contractor warrants that it is not presently debarred, suspended, proposed for debarment, declared ineligible, or voluntarily excluded from participation in covered transactions by any federal department or agency. Contractor also warrants that it is not suspended or debarred from

receiving federal funds as listed in the "List of Parties Excluded from Federal Procurement or Nonprocurement Programs" issued by the General Services Administration. If Contractor becomes debarred, Contractor has the obligation to inform County.

9.4. Taxes

Contractor agrees to file federal and state tax returns and pay all applicable taxes on amounts paid pursuant to this Agreement, and shall be solely liable and responsible to pay such taxes and other obligations, including but not limited to state and federal income and FICA taxes. Contractor agrees to indemnify and hold County harmless from any liability which it may incur to the United States or to the State of California as a consequence of Contractor's failure to pay, when due, all such taxes and obligations. In case County is audited for compliance regarding any withholding or other applicable taxes, Contractor agrees to furnish County with proof of payment of taxes on these earnings.

9.5. Records Maintenance

Contractor shall keep and maintain full and complete documentation and accounting records concerning all services provided under this Agreement. Records shall include all medical records, accounting records, and administrative records related to services provided hereunder. Contractor agrees to preserve and maintain such records for a period of at least 7 years following the close of County and state fiscal year in which the services were provided. If an audit has been started, records must be retained until completion and final resolution of any and all issues that might arise. Final settlement shall be made at the end of the audit and appeal process. All accounting records shall be maintained so that they clearly reflect the source of funding for each type of service for which reimbursement is claimed by Contractor. Accounting records include, but are not limited to, all ledgers, books, vouchers, time sheets, payrolls, appointment schedules, client data cards, and schedules for allocating costs.

9.5.1. Right to Audit, Inspect, and Copy Records

Contractor agrees to permit County and any authorized state or federal agency to audit, inspect, and copy all records, notes, and writings of any kind in connection with the services provided by Contractor under this Agreement, to the extent permitted by law, for the purpose of monitoring the quality and quantity of services, monitoring the accessibility and appropriateness of services, and ensuring fiscal accountability. All such audits, inspections, and copying shall occur during normal business hours. Upon request, Contractor shall supply copies of any and all such records to County. Failure to provide the above-noted documents requested by County within the requested time frame indicated may result in County withholding payments due under this Agreement. In those situations required by applicable law(s), Contractor agrees to obtain necessary releases to permit County or governmental or accrediting agencies to access patient medical records.

9.6. Conflict of Interest

Contractor covenants that it presently has no interest and that it will not acquire any interest, direct or indirect, that represents a financial conflict of interest under state law or that would otherwise conflict in any manner or degree with the performance of its services hereunder. Contractor further covenants that in the performance of this Agreement, no person having any such interests shall be employed. In addition, if requested to do so by County, Contractor shall complete and file and shall require any other person doing work under this Agreement to

complete and file a "Statement of Economic Interest" with County disclosing Contractor's or such other person's financial interests.

9.7. Statutory Compliance/Living Wage Ordinance

Contractor agrees to comply, and to ensure compliance by its subconsultants or subcontractors, with all applicable federal, state and local laws, regulations, statutes and policies, including but not limited to the County of Sonoma Living Wage Ordinance, applicable to the services provided under this Agreement as they exist now and as they are changed, amended, or modified during the term of this Agreement. Without limiting the generality of the foregoing, Contractor expressly acknowledges and agrees that this Agreement is subject to the provisions of Article XXVI of Chapter 2 of the Sonoma County Code, requiring payment of a living wage to covered employees. Noncompliance during the term of the Agreement will be considered a material breach and may result in termination of the Agreement or pursuit of other legal or administrative remedies.

9.8. Nondiscrimination

Without limiting any other provision hereunder, Contractor shall comply with all applicable federal, state, and local laws, rules, and regulations in regard to nondiscrimination in employment because of race, color, ancestry, national origin, religious creed, belief or grooming, sex (including sexual orientation, gender identity, gender expression, transgender, pregnancy, childbirth, medical conditions related to pregnancy, childbirth or breast feeding), marital status, age, medical condition, physical or mental disability, genetic information, military or veteran status, or any other legally protected category or prohibited basis, including without limitation, the County's Non-Discrimination Policy. All nondiscrimination rules or regulations required by law to be included in this Agreement are incorporated herein by this reference.

9.9. AIDS Discrimination

Contractor agrees to comply with the provisions of Chapter 19, Article II, of the Sonoma County Code prohibiting discrimination in housing, employment, and services because of AIDS or HIV infection during the term of this Agreement and any extensions of the term.

9.10. Assignment of Rights

Contractor assigns to County all rights throughout the world in perpetuity in the nature of copyright, trademark, patent, and right to ideas in and to all versions of the plans and specifications, if any, now or later, prepared by Contractor in connection with this Agreement. Contractor agrees to take such actions as are necessary to protect the rights assigned to County in this Agreement, and to refrain from taking any action which would impair those rights. Contractor's responsibilities under this provision include, but are not limited to, placing proper notice of copyright on all versions of the plans and specifications as County may direct, and refraining from disclosing any versions of the plans and specifications to any third party without first obtaining written permission of County. Contractor shall not use or permit another party to use the plans and specifications in connection with this or any other project without first obtaining written permission of County.

9.11. Ownership and Disclosure of Work Product

All reports, original drawings, graphics, plans, studies, and other data or documents ("documents"), in whatever form or format, assembled or prepared by Contractor or Contractor's

subcontractors, consultants, and other agents in connection with this Agreement, shall be the property of County. County shall be entitled to immediate possession of such documents upon completion of the work pursuant to this Agreement. Upon expiration or termination of this Agreement, Contractor shall promptly deliver to County all such documents which have not already been provided to County in such form or format as County deems appropriate. Such documents shall be and will remain the property of County without restriction or limitation. Contractor may retain copies of the above-described documents, but agrees not to disclose or discuss any information gathered, discovered, or generated in any way through this Agreement without the express written permission of County.

9.12. Authority

The undersigned hereby represents and warrants that he or she has authority to execute and deliver this Agreement on behalf of Contractor.

9.13. Sanctioned Employee

Contractor agrees that it shall not employ in any capacity, or retain as a subcontractor in any capacity, any individual or entity that is listed on any list published by the Federal Office of Inspector General regarding the sanctioning, suspension, or exclusion of individuals or entities from the federal Medicare and Medicaid programs. Contractor agrees to monthly review said state and federal lists to confirm the status of current employees, subcontractors, and contractors. In the event Contractor does employ such individual(s) or entity(ies), Contractor agrees to assume full liability for any associated penalties, sanctions, loss, or damage that may be imposed on County by the Medicare or Medicaid programs.

9.14. Compliance with County Policies and Procedures

Contractor agrees to comply with all County policies and procedures as they may relate to services provided hereunder, including, but not limited to, County's policies and procedures, manuals, programs, and processes related to selection, retention, credentialing and recredentialing providers, utilization management, quality management, compliance, grievances, appeals, and expedited appeals, advanced directives, and administrative manual.

9.15. Confidentiality

Contractor agrees to maintain the confidentiality of all patient medical records and client information in accordance with all applicable state and federal laws and regulations. This Section 9.15 shall survive termination of this Agreement.

9.16. Lobbying

If any federal funds are to be used to pay for any services under this Agreement, Contractor shall fully comply with all certifications and disclosure requirements prescribed by Section 319 of the Public Law 101-121 (31 United States Code Section 1352) and any implementing regulations, and shall ensure that each of its subcontractors receiving funds under this Agreement also fully complies with all such certification and disclosure requirements.

9.17. Subcontractors

Contractor agrees that any employees or agents of Contractor that assist Contractor in the provision of services shall also satisfy the requirements of this Agreement. In this regard, Contractor understands and agrees that all obligations and prohibitions imposed on Contractor

pursuant to this Agreement are equally applicable to each and every individual providing services through Contractor under this Agreement, and Contractor shall assure that such individuals agree to comply with such obligations and prohibitions.

9.18. Licensure and Staffing

Contractor warrants that it and all its employees and sub-contractors providing or supervising services under this Agreement have all necessary licenses, permits, and certificates to provide services under this Agreement, as required by applicable state and federal laws, rules, and regulations. Contractor agrees to maintain said licenses, permits, and certificates in good standing for the duration of this Agreement. A copy of each such licenses, permits, and certificates shall be made available upon request, not to exceed three (3) business days after the initial request, for inspection, review, and/or audit by authorized representatives and designees of County, state, and/or federal governments during the term of this Agreement and for the applicable records retention period. Failure to maintain said licenses, permits, and/or certificates in effect for the duration of this Agreement shall be deemed a material breach of this Agreement and constitutes grounds for immediate termination of this Agreement by County. Staff shall only function within the scope of practice as dictated by licensing boards/bodies. At all times during the term of this Agreement, Contractor shall have available and shall provide upon request to authorized representatives of County a list of all persons by name, title, professional degree, and experience who are providing any services under this Agreement.

9.19. Charitable Choice/Faith-Based Organizations

Contractor agrees and acknowledges that County may make funds available for programs or services affiliated with religious organizations under the following conditions: (i) the funds are made available on an equal basis for programs or services affiliated with non-religious organizations; (ii) the program funded does not have the substantial effect of supporting religious activities; (iii) the funding is indirect, remote, or incidental to the religious purpose of the organization.

9.19.1. Contractor agrees and acknowledges that County may not make funds available for programs or services affiliated with a religious organization that (i) has denied or continues to deny access to services on the basis of race, color, religion, ancestry, national origin, sex, citizenship, or known disability; (ii) will use the funds for a religious purpose; (iii) will use the funds for a program or service that subjects its participants to religious education.

9.19.2. Contractor agrees and acknowledges that all recipients of funding from County must (i) comply with all legal requirements and restrictions imposed upon government-funded activities set forth in Article IX, Section 8 and Article XVI, Section 5 of the California Constitution and in the First Amendment to the United States Constitution; and (ii) segregate such funding from all funding used for religious purposes.

10. Demand for Assurance

Each party to this Agreement undertakes the obligation that the other party's expectation of receiving due performance will not be impaired. When reasonable grounds for insecurity arise with respect to the performance of either party, the other party may in writing demand adequate assurance of due performance, and until such assurance is received may, if commercially

reasonable, suspend any performance for which the agreed return has not been received. "Commercially reasonable" includes not only the conduct of a party with respect to performance under this Agreement, but also conduct with respect to other agreements with parties to this Agreement or others. After receipt of a justified demand, failure to provide within a reasonable time, but not exceeding 30 days, such assurance of due performance as is adequate under the circumstances of the particular case is a repudiation of this Agreement. Acceptance of any improper delivery, service, or payment does not prejudice the aggrieved party's right to demand adequate assurance of future performance. Nothing in this Article limits County's right to terminate this Agreement pursuant to Article 4 (Termination).

11. Assignment and Delegation

Neither party hereto shall assign, delegate, sublet, or transfer any interest in or duty under this Agreement without the prior written consent of the other party, and no such transfer shall be of any force or effect whatsoever unless and until the other party shall have so consented.

12. Method and Place of Giving Notice, Submitting Bills, and Making Payments

All notices, bills, and payments shall be made in writing and shall be given by personal delivery or by U.S. Mail or courier service. Notices, bills, and payments shall be addressed as follows:

To County:

Angie Dillon-Shore
Executive Director
First 5 Sonoma County
490 Mendocino Avenue, Suite 203
Santa Rosa CA 95401
707.565.6686
Angie.Dillon-Shore@sonoma-county.org

To Contractor:

Melanie Dodson
Executive Director
Community Child Care Council of Sonoma County
131-A Stony Circle Suite 300
Santa Rosa CA 95401
707.522.1413
mdodson@sonoma4cs.org

When a notice, bill, or payment is given by a generally recognized overnight courier service, the notice, bill, or payment shall be deemed received on the next business day. When a copy of a notice, bill, or payment is sent by facsimile or email, the notice, bill, or payment shall be deemed received upon transmission as long as: (1) the original copy of the notice, bill, or payment is promptly deposited in the U.S. Mail and postmarked on the date of the facsimile or email (for a payment, on or before the due date); (2) the sender has a written confirmation of the facsimile transmission or email; and (3) the facsimile or email is transmitted before 5 p.m. (recipient's time). In all other instances, notices, bills, and payments shall be effective upon receipt by the recipient. Changes may be made in the names and addresses of the person to whom notices are to be given by giving notice pursuant to this Article 12.

13. Miscellaneous Provisions

13.1. No Waiver of Breach

The waiver by County of any breach of any term or promise contained in this Agreement shall not be deemed to be a waiver of such term or provision or any subsequent breach of the same or any other term or promise contained in this Agreement.

13.2. Construction

To the fullest extent allowed by law, the provisions of this Agreement shall be construed and given effect in a manner that avoids any violation of statute, ordinance, regulation, or law. The parties covenant and agree that in the event that any provision of this Agreement is held by a court of competent jurisdiction to be invalid, void, or unenforceable, the remainder of the provisions hereof shall remain in full force and effect and shall in no way be affected, impaired, or invalidated thereby. Contractor and County acknowledge that they have each contributed to the making of this Agreement and that, in the event of a dispute over the interpretation of this Agreement, the language of the Agreement will not be construed against one party in favor of the other party. Contractor and County acknowledge that they have each had an adequate opportunity to consult with counsel in the negotiation and preparation of this Agreement.

13.3. Consent

Wherever in this Agreement the consent or approval of one party is required to an act of the other party, such consent or approval shall not be unreasonably withheld or delayed.

13.4. No Third-Party Beneficiaries

Nothing contained in this Agreement shall be construed to create and the parties do not intend to create any rights in third parties.

13.5. Applicable Law and Forum

This Agreement shall be construed and interpreted according to the substantive law of California, regardless of the law of conflicts to the contrary in any jurisdiction. Any action to enforce the terms of this Agreement or for the breach thereof shall be brought and tried in the City of Santa Rosa or the forum nearest to the City of Santa Rosa in the County of Sonoma.

13.6. Captions

The captions in this Agreement are solely for convenience of reference. They are not a part of this Agreement and shall have no effect on its construction or interpretation.

13.7. Merger

This writing is intended both as the final expression of the Agreement between the parties hereto with respect to the included terms and as a complete and exclusive statement of the terms of the Agreement, pursuant to Code of Civil Procedure Section 1856. Each party acknowledges that, in entering into this Agreement, it has not relied on any representation or undertaking, whether oral or in writing, other than those which are expressly set forth in this Agreement. No modification of this Agreement shall be effective unless and until such modification is evidenced by a writing signed by both parties.

13.8. Survival of Terms

All express representations, waivers, indemnifications, and limitations of liability included in this Agreement will survive its completion or termination for any reason.

13.9. Time of Essence

Time is and shall be of the essence of this Agreement and every provision hereof.

13.10. Counterparts and Electronic Copies

The parties agree that, where applicable, this Agreement may be executed in counterparts, together which when executed by the requisite parties shall be deemed to be a complete original agreement. An electronic copy, including facsimile copy, email, or scanned copy of the executed Agreement or counterpart, shall be deemed, and shall have the same legal force and effect as, an original document.

§ The remainder of this page has intentionally been left blank. §

IN WITNESS WHEREOF, the parties hereto have executed this Agreement as of the Effective Date.

CONTRACTOR:

Melanie Dodson, Executive Director
Community Child Care Council of Sonoma County

Dated

COUNTY OF SONOMA:
Certificate of Insurance on File with County:

Barbie Robinson, Director
Department of Health Services

Dated

Approved as to Substance:

Angie Dillon-Shore, Executive Director
First 5 Sonoma County Commission

Dated

Approved as to Form:



Sonoma County Counsel

Dated

10/2/18

Dated

Exhibit A. Scope of Work

Project Title	California State Preschool Program (CSPP) Round 5 Coaching and Incentives
Project Summary	Distribute Commission-directed Quality Rating and Improvement System (QRIS) Tier-Rating awards to California State Preschool Program (CSPP) sites with high quality ratings (i.e., Tier 4 or 5). Provide quality coaching services to all CSPP sites participating in Sonoma County’s local QRIS, Quality Counts.

Core Activity	Timeline	Title of Person(s) Responsible	Implementation Data to be Reported
Distribute financial awards to CSPP sites earning quality ratings of Tier 4 or 5 as directed by Commission.	Jul 1, 2018 – Sep 30, 2019	Finance Director	Invoice records
Provide quality coaching services to CSPP sites.	Jul 1, 2018 – Sep 30, 2019	Quality Counts Program Director Quality Counts Early Learning Coaches	iPinwheel data for all CSPP sites participating in Quality Counts, including: <ul style="list-style-type: none"> ○ Coaching logs ○ Agency-level data ○ Site-level data

Exhibit B. Budget

Personnel		FY 18-19	FY 19-20	Total
		\$	\$	\$
	Job Title			
1.	Program Director	9,750	2,438	12,188
2.	Early Learning Coach II	52,000	13,000	65,000
Subtotal Salaries		61,750	15,438	77,188
	Benefits	11,863	2,966	14,829
Total Personnel		73,613	18,404	92,017
Operating Expenses				
1.	Program Supplies	500	125	625
2.	Travel	1,200	300	1,500
3.	Incentives	153,000	17,000	170,000
Total Operating Expenses		154,700	17,425	172,125
Subtotal Budget		228,313	35,829	264,142
Indirect Costs (not to exceed 15% of subtotal budget)		34,247	5,374	39,621
Total		262,560	41,203	303,763

Exhibit C. Insurance Requirements
(Template 3 – Rev 2018 Sep 13)

With respect to performance of work under this Agreement, Contractor shall maintain and shall require all of its subcontractors, consultants, and other agents to maintain insurance as described below unless such insurance has been expressly waived by the attachment of a Waiver of Insurance Requirements. Any requirement for insurance to be maintained after completion of the work shall survive this Agreement.

County reserves the right to review any and all of the required insurance policies and/or endorsements, but has no obligation to do so. Failure to demand evidence of full compliance with the insurance requirements set forth in this Agreement or failure to identify any insurance deficiency shall not relieve Contractor from, nor be construed or deemed a waiver of, its obligation to maintain the required insurance at all times during the performance of this Agreement.

1. Workers Compensation and Employers Liability Insurance

- a. Required if Contractor has employees as defined by the Labor Code of the State of California.
- b. Workers Compensation insurance with statutory limits as required by the Labor Code of the State of California.
- c. Employers Liability with minimum limits of \$1,000,000 per Accident; \$1,000,000 Disease per employee; \$1,000,000 Disease per policy.
- d. ***Required Evidence of Insurance:*** Certificate of Insurance.
- e. If Contractor currently has no employees as defined by the Labor Code of the State of California, Contractor agrees to obtain the above-specified Workers Compensation and Employers Liability insurance should employees be engaged during the term of this Agreement or any extensions of the term.

2. General Liability Insurance

- a. Commercial General Liability Insurance on a standard occurrence form, no less broad than Insurance Services Office (ISO) form CG 00 01.
- b. Minimum Limits: \$1,000,000 per Occurrence; \$2,000,000 General Aggregate; \$2,000,000 Products/Completed Operations Aggregate. The required limits may be provided by a combination of General Liability Insurance and Commercial Excess or Commercial Umbrella Liability Insurance. If Contractor maintains higher limits than the specified minimum limits, County requires and shall be entitled to coverage for the higher limits maintained by Contractor.
- c. Any deductible or self-insured retention shall be shown on the Certificate of Insurance. If the deductible or self-insured retention exceeds \$25,000, it must be approved in advance by County. Contractor is responsible for any deductible or self-insured retention and shall fund it upon County's written request, regardless of whether Contractor has a claim against the insurance or is named as a party in any action involving the County.

-
- d. **"First 5 Sonoma County Commission and the County of Sonoma, their Officers, Agents, and Employees"** shall be endorsed as **additional insureds** for liability arising out of operations by or on behalf of the Contractor in the performance of this Agreement.
 - e. The insurance provided to the additional insureds shall be primary to, and non-contributory with, any insurance or self-insurance program maintained by them.
 - f. The policy definition of "insured contract" shall include assumptions of liability arising out of both ongoing operations and the products-completed operations hazard (broad form contractual liability coverage including the "f" definition of insured contract in ISO form CG 00 01, or equivalent).
 - g. The policy shall cover inter-insured suits between the additional insureds and Contractor and include a "separation of insureds" or "severability" clause which treats each insured separately.
 - h. ***Required Evidence of Insurance***
 - i. Copy of the additional insured endorsement or policy language granting additional insured status; and
 - ii. Certificate of Insurance.
3. Automobile Liability Insurance
- a. Minimum Limit: \$1,000,000 combined single limit per accident. The required limit may be provided by a combination of Automobile Liability Insurance and Commercial Excess or Commercial Umbrella Liability Insurance.
 - b. Insurance shall cover all owned autos. If Contractor currently owns no autos, Contractor agrees to obtain such insurance should any autos be acquired during the term of this Agreement or any extensions of the term.
 - c. Insurance shall cover hired and non-owned autos.
 - d. ***Required Evidence of Insurance***: Certificate of Insurance.
4. Standards for Insurance Companies
- Insurers, other than the California State Compensation Insurance Fund, shall have an A.M. Best's rating of at least A:VII.
5. Documentation
- a. All required Evidence of Insurance shall be submitted prior to the execution of this Agreement. Contractor agrees to maintain current Evidence of Insurance on file with County for the entire term of this Agreement and any additional periods if specified in Sections 1, 2 or 3 above.

- b. The name and **address** for Additional Insured endorsements and Certificates of Insurance is:

**First 5 Sonoma County Commission and the County of Sonoma, their
Officers, Agents, and Employees
Attn: DHS – Contract & Board Item Development Unit
3313 Chanate Road
Santa Rosa CA 95404
Email: DHS-Contracting@sonoma-county.org**

- c. Required Evidence of Insurance shall be submitted for any renewal or replacement of a policy that already exists, at least ten (10) days before expiration or other termination of the existing policy.
- d. Contractor shall provide immediate written notice if: (1) any of the required insurance policies is terminated; (2) the limits of any of the required policies are reduced; or (3) the deductible or self-insured retention is increased.
- e. Upon written request, certified copies of required insurance policies must be provided within thirty (30) days.

6. Policy Obligations

Contractor's indemnity and other obligations shall not be limited by the foregoing insurance requirements.

7. Material Breach

If Contractor fails to maintain insurance which is required pursuant to this Agreement, it shall be deemed a material breach of this Agreement. County, at its sole option, may terminate this Agreement and obtain damages from Contractor resulting from said breach. Alternatively, County may purchase the required insurance, and without further notice to Contractor, County may deduct from sums due to Contractor any premium costs advanced by County for such insurance. These remedies shall be in addition to any other remedies available to County.



County of Sonoma
State of California

Date: November 13, 2018

Item Number: _____

Resolution Number: _____



4/5 Vote Required

Resolution of the Board of Supervisors of the County of Sonoma, State of California, Authorizing Budgetary Adjustments to the Fiscal Year 2018-2019 Adopted Budget, Appropriating \$287,560 from a Sonoma County Office of Education Grant to the Health Services Special Revenue Fund to Allocate Funding for First 5 Sonoma County-Related Expenditures Within the Department of Health Services

Whereas, the Board of Supervisors has adopted the final budget for fiscal year 2018-2019 in accordance with Section 29088 of the Government Code of the State of California; and

Whereas, the Government Code allows for adjustments to the adopted budget during the 2018-2019 fiscal year.

Now, Therefore, Be It Resolved that the Board of Supervisors, County of Sonoma, State of California, does hereby authorize and direct the County Auditor-Controller to adjust the fiscal year 2018-2019 adopted budget for the increases listed in Exhibit A.

Supervisors:

Gorin:

Rabbitt:

Zane:

Hopkins:

Gore:

Ayes:

Noes:

Absent:

Abstain:

So Ordered.

EXHIBIT A - BUDGET RESOLUTION

Department(s)/ Agency/(ies): Department of Health Services

Narratives	FTE Impacts (+/-)	Gross Expenditure	Revenue and Reimbursement	Net Cost	Annualized Net Cost
------------	-------------------------	----------------------	------------------------------	----------	------------------------

Summary of Requested Adjustments for Board Consideration

Health Services - OTHER FUND					
Detail Row 1	<i>Increase revenues receipt of Sonoma County Office of Education .</i>			323,777	(323,777)
Detail Row 2	<i>Increase expenditures for contracts with Community Child Care Council and additional Quality Count-related services agreements.</i>		287,560		287,560
Detail Row 3					-
Summary Row	<i>NOTE: HIDE the detail rows if the summary is simply a restatement of the details.</i>	-	287,560	323,777	(36,217)

Total Requested Adjustments	0	287,560	323,777	(36,217)	0
<i>Subtotal of General Fund Changes</i>	0	0	0	0	0
<i>Subtotal of Other Fund Changes</i>	0	287,560	323,777	(36,217)	0



County of Sonoma Agenda Item Summary Report

Clerk of the Board
575 Administration Drive
Santa Rosa, CA 95403

Agenda Item Number: 30
(This Section for use by Clerk of the Board Only.)

To: Board of Supervisors of the County of Sonoma, Board of Directors of the Sonoma County Water Agency, Board of Commissioners of the Community Development Commission, Board of Directors of the Sonoma County Agricultural Preservation and Open Space District

Board Agenda Date: November 13, 2018

Vote Requirement: Majority

Department or Agency Name(s): Human Resources and County Counsel

Staff Name and Phone Number:

Victoria Willard, Equal Employment Opportunity
Officer (707) 565-2955

Supervisorial District(s):

All

Title: Investigation Service Agreement Third Amendment

Recommended Actions:

Authorize the Director of Human Resources and County Counsel to execute a third amendment to the existing master agreement with Kronick, Moskovitz, Tiedemann & Girard for workplace investigations for an additional two year term (October 1, 2018 to September 30, 2020) with an amount not to exceed \$525,000.

Executive Summary:

The County's master agreement with Kronick, Moskovitz, Tiedemann & Girard is due to expire on September 30, 2018. The requested Board action authorizes the Human Resources Director and County Counsel to execute an amendment to the existing master agreement with Kronick, Moskovitz, Tiedemann & Girard for an additional two year term, October 1, 2018 to September 30, 2020.

Discussion:

Under certain circumstances it is appropriate for outside counsel and/or individuals specializing in workplace investigations to conduct investigations instead of County staff. Reasons may include: the complexity of the case, insufficient staff time to complete a timely investigation; the need to have attorney-client privileged work; high risk of litigation; staff without sufficient experience or training in workplace investigations; and the need to minimize potential conflicts or biased outcomes. Outside investigators are expected to be credible, thorough, impartial, and act as neutral fact finders.

Human Resources conducted a Request for Proposal in 2013 and implemented a master agreement with Kronick, Moskovitz, Tiedemann & Girard for the contract period October 1, 2013 through September 30, 2017. In August 2016, Human Resources executed an amendment to increase the contract maximum from \$100,000 to \$175,000 per contract year. Human Resources will be re-soliciting Requests for Proposal

for Investigative Firm before then end of this term as the standard procurement process requires. Kronick, Moskovitz, Tiedemann & Girard's rates are increasing by 6.7% which equates to a \$15.00 an hour increase from \$225.00 an hour to \$240.00 an hour.

In October 2017, Human Resources executed a second amendment to the existing master agreement with Kronick, Moskovitz, Tiedemann & Girard for workplace investigations for an additional one year term (October 1, 2017 to September 30, 2018) with an amount not to exceed \$175,000.

Kronick, Moskovitz, Tiedemann & Girard is currently in the process of conducting workplace investigations at the County. To ensure we maintain the continuity and integrity of the investigation process, it is recommended that authorization be granted to the Human Resource Director to execute an amendment to the existing master agreement with Kronick, Moskovitz, Tiedemann & Girard for an additional two year term (October 1, 2018 to September 30, 2020).

Prior Board Actions:

- 9/09/2008 – Approved initial master service agreements with (6) firms.
- 9/27/2011 – Approved 2 year amendments to master services agreements with (6) firms.
- 9/24/2013 – Approved agreements with (14) selected investigative firms.
- 8/09/2016 – Approved amendments to increase contract maximum agreements with (14) selected investigative firms from \$100,000 maximum per contract year to \$175,000 maximum per contract year.
- 9/12/2017 – Approved Workplace Investigation Service Agreements with nine firms
- 10/03/2017- Approved Workplace Investigation Service Agreements second amendment to the existing master contract with Kronick, Moskovitz, Tiedemann & Girard

Strategic Plan Alignment Goal 1: Safe, Healthy, and Caring Community

Investigating employee conduct concerns is important to having an engaged and productive workforce, who in turn provide services to the community. Ensuring the County is an equal opportunity employer and does not discriminate against individuals with disabilities or who are otherwise in a protected class results in a better overall community.

Fiscal Summary			
Expenditures	FY 18-19 Adopted	FY 19-20 Projected	FY 20-21 Projected
Budgeted Expenses			
Additional Appropriation Requested			
Total Expenditures			
Funding Sources			
General Fund/WA GF			
State/Federal			
Fees/Other			
Use of Fund Balance			
Contingencies			
Total Sources			
Narrative Explanation of Fiscal Impacts:			
<p>Cost for services requested by the Human Resources Department Equal Employment Opportunity Unit are administered within the Liability Internal Services Fund (ISF), and Departments that request to utilize investigative contract services pay for services out of their respective budgets. For Fiscal year 2017-2018 the County spent \$80,000 and for the current Fiscal year 2018 – 2019 to date the County has spent approximately \$25,000.</p>			
Staffing Impacts			
Position Title (Payroll Classification)	Monthly Salary Range (A – I Step)	Additions (Number)	Deletions (Number)
Narrative Explanation of Staffing Impacts (If Required):			
Attachments:			
Draft Amendment			
Related Items “On File” with the Clerk of the Board:			
Original Agreement for Investigative Services Amendments to the Agreement			

DRAFT
THIRD AMENDMENT TO
PROFESSIONAL SERVICES AGREEMENT

This Third Amendment ("Amendment"), dated as of October 1, 2018, is by and between the County of Sonoma, a political subdivision of the State of California ("County"), and **Kronick, Moskovitz, Tiedemann & Girard**, a Law Corporation, hereinafter referred to as ("Contractor").

RECITALS

WHEREAS, County and Contractor entered into that certain Agreement, dated October 1, 2013, for Employment Related Investigations and Consulting Services; and

WHEREAS, County and Contractor desire to amend the Agreement extend the term an additional two years and set the contract maximum for that term at not to exceed \$525,000,

NOW, THEREFORE, for good and valuable consideration, the receipt and sufficiency of which are hereby acknowledged, the parties hereto agree as follows:

AGREEMENT

1. Section 2. Payment shall be amended to set the contract maximum at **\$525,000** for the contract term October 1, 2018 to September 30, 2020.
2. Section 3. Term of Agreement. The term of this Agreement shall be extended for a two year period until **September 30, 2020** unless terminated earlier in accordance with the provisions of Article 4 below.
3. Section 9.7 Statutory Compliance/Living Wage Ordinance. Contractor agrees to comply, and to ensure compliance by its subconsultants or subcontractors, with all applicable federal, state and local laws, regulations, statutes and policies, including but not limited to the County of Sonoma Living Wage Ordinance, applicable to the services provided under this Agreement as they exist now and as they are changed, amended or modified during the term of this Agreement. Without limiting the generality of the foregoing, Contractor expressly acknowledges and agrees that this Agreement may be subject to the provisions of Article XXVI of Chapter 2 of the Sonoma County Code, requiring payment of a living wage to covered employees. Noncompliance during the term of the Agreement will be considered a material breach and may result in termination of the Agreement or pursuit of other legal or administrative remedies.
4. Except to the extent the Agreement is specifically amended or supplemented hereby, the Agreement, together with exhibits is, and shall continue to be, in full force and effect as originally executed, and nothing contained herein shall, or shall be construed to modify, invalidate or otherwise affect any provision of the Agreement or any right of County arising thereunder.
5. This Amendment shall be governed by and construed under the internal laws of the state of California, and any action to enforce the terms of this Amendment or for the breach thereof shall be brought and tried in the County of Sonoma.

COUNTY AND CONTRACTOR HAVE CAREFULLY READ AND REVIEWED THIS AMENDMENT AND EACH TERM AND PROVISION CONTAINED HEREIN AND, BY EXECUTION OF THIS AMENDMENT, SHOW THEIR INFORMED AND VOLUNTARY CONSENT THERETO.

IN WITNESS WHEREOF, the parties hereto have executed this Amendment as of the effective date.

CONTRACTOR:
Kronick, Moskovitz, Tiedemann & Girard

By: _____

Name: _____

Title: _____

Date: _____

COUNTY OF SONOMA:

By: _____
Christina Cramer, Director of Human Resources

Date: _____

APPROVED AS TO FORM FOR COUNTY:

By: _____
County Counsel

Date: _____

CERTIFICATES OF INSURANCE ON FILE WITH AND APPROVED AS TO SUBSTANCE FOR COUNTY:

By: _____
Christina Cramer, Director of Human Resources

Date: _____



County of Sonoma Agenda Item Summary Report

Clerk of the Board
575 Administration Drive
Santa Rosa, CA 95403

Agenda Item Number: 31
(This Section for use by Clerk of the Board Only.)

To: Board of Supervisors

Board Agenda Date: November 13, 2018

Vote Requirement: 4/5

Department or Agency Name(s): Information Systems Department

Staff Name and Phone Number:

Carolyn Staats, 565-5472

Supervisorial District(s):

Title: Approval of Department of Health Services, Public Health - Environmental Health Records Retention Schedule Version Number 3 and Department of Health Services, Public Health - Animal Services Records Retention Schedule Version Number 3.

Recommended Actions:

Adopt a Resolution approving the revised records retention schedules for the Department of Health Services, Public Health - Environmental Health and Department of Health Services, Public Health - Animal Services and authorizing the destruction of records in accordance with the approved retention schedules.

Executive Summary:

This item requests board consideration and approval of a revision to the current retention schedules for Department of Health Services, Public Health – Environmental Health and Department of Health Services (DHS), Public Health – Animal Services. These revisions will streamline the recordkeeping process by consolidating items of a similar nature, adding new record types, removing obsolete items, and eliminating redundancies.

Discussion:

In compliance with Administrative Policy 6-1 (Policy for Records Retention, Storage and Destruction), records retention schedules are created jointly by departments and Records Management to establish how long records should be maintained based on their operational, legal, fiscal and historical value. Retention schedules become the legal authority for the terms of destruction of County of Sonoma records.

Revised retention schedules have been prepared for Department of Health Services, Public Health - Environmental Health and Department of Health Services, Public Health - Animal Services. The retention schedules were developed to provide continuing guidance and authority to the department for both retention and destruction of records. These schedules are the third versions for Environmental Health and Animal Services, the initial versions were approved 8/6/1996 (Consumer Protection), 9/27/1994

(Hazardous Materials) and 6/2/1992 (Animal Regulation). Retention schedules have been adjusted over the years for various reasons including: adding series for new programs, removing series no longer created, or modifying retention periods based on operational value.

Notable changes from versions two to versions three are as follows:

- Aligning records within their current divisional structure. Records were previously categorized under the divisions of Consumer Protection and Hazardous Materials but are currently managed under the Environmental Health division umbrella.
- Establishing media neutral schedules – currently the schedules mandate what media (format) in which a record must be held (i.e. paper, microfiche, disk). With technological advances, many departments are using newer systems which create the records entirely in electronic form. Having a schedule that specifies media format is archaic, restrictive and cost prohibitive as departments are unnecessarily required to store physical records in order to comply with the retention schedule when electronic storage options are available and more cost effective. Additionally, records management best practices do not support the mandatory retention of duplicate records.
- Creation of “big bucket” records series. This process consolidates record types related to the same business process or function into one comprehensive records series or “bucket”. This streamlines recordkeeping practices and mirrors operational functions. This is also expected to improve departmental abilities to appropriately identify retention periods for records.
- Addition of a new records series under Environmental Health to reflect the records of the Right-of-Entry/Debris Management program created following the October 2017 complex of fires.

All retention periods have been thoroughly reviewed by the Records Manager, the Department Head, Auditor-Controller, County Counsel, and the County Historical Records Commission to ensure that administrative, legal, fiscal and archival requirements have been met. The attachment “Request for Approval of Records Retention Schedule” documents the review and approval by these entities.

Prior Board Actions:

11/4/1997: Resolution #97-1417 approving revised retention schedule number two for Health Services – Animal Regulation division.

3/4/1997: Resolution #97-0253 approving revised retention schedule number two for the Public Health – Environmental Health – Hazardous Materials division.

8/6/1996: Resolution #96-1060 approving the original retention schedule number one for the Public Health – Environmental Health – Consumer Protection division.

9/27/1994: Resolution #94-1396 approving the original retention schedule number one for the Public Health – Environmental Health – Hazardous Materials division.

06/2/1992: Resolution #92-0834 approving the original retention schedule number one for the Agricultural Commissioner Animal Regulation division

Strategic Plan Alignment Goal 3: Invest in the Future

Ensure the relevancy, continuity, viability and transparency of government records.

Fiscal Summary

Expenditures	FY 18-19 Adopted	FY 19-20 Projected	FY 20-21 Projected
Budgeted Expenses			
Additional Appropriation Requested			
Total Expenditures			

Funding Sources

General Fund/WA GF			
State/Federal			
Fees/Other			
Use of Fund Balance			
Contingencies			
Total Sources			

Narrative Explanation of Fiscal Impacts:

There are no costs associated with this recommended action.

Staffing Impacts

Position Title (Payroll Classification)	Monthly Salary Range (A – I Step)	Additions (Number)	Deletions (Number)

Narrative Explanation of Staffing Impacts (If Required):

N/A

Attachments:

- 1) Resolution approving Records Retention Schedules and authorizing destruction of records.
- 2) Retention Schedule – Department of Health Services, Public Health – Environmental Health.
- 3) Retention Schedule – Department of Health Services, Public Health – Animal Services.
- 4) Requests for Approval of Records Retention Schedule.

Related Items "On File" with the Clerk of the Board:



County of Sonoma
State of California

Date: November 13, 2018

Item Number: _____
Resolution Number: _____



4/5 Vote Required

**Resolution Of The Board Of Supervisors Of The County Of Sonoma, State Of California,
authorizing the revision to the retention schedules for Department of Health Services, Public
Health – Environmental Health and Department of Health Services, Public Health – Animal
Services.**

Whereas, Government Code Section 26200 et seq. authorizes the Board of Supervisors to adopt records retention schedules setting forth the duration that county records must be retained and authorizing the destruction or any other disposition of records at the conclusion of the record retention period specified in the schedules; and

Whereas, the proposed records retention schedules have been extensively reviewed as set forth in the “Request for Approval of Records Retention Schedule”; and

Whereas, the retention schedules supersede any previous schedule approved by the Board of Supervisors; and

Whereas, records retention schedules constitute an active, continuing program for the preservation or disposal of records and approval of a records retention schedule constitutes continuing approval for the department head to properly dispose of the records as indicated on the schedule.

Now, Therefore, Be It Resolved that the Board of Supervisors of the County of Sonoma approves the records retention schedules and authorizes the preservation or destruction of records in accordance with the approved schedules for the following departments:

**Department of Health Services – Public Health – Environmental Health Version
Number 3**

Department of Health Services – Public Health – Animal Services Version Number 3

Supervisors:

Gorin:

Rabbitt:

Zane:

Hopkins:

Gore:

Resolution #

Date:

Page 2

Ayes:

Noes:

Absent:

Abstain:

So Ordered.

RETENTION SCHEDULE FOR THE DEPARTMENT OF HEALTH SERVICES - PUBLIC HEALTH - ENVIRONMENTAL HEALTH

DEPARTMENT	DIVISION	ITEM #		TITLE	DESCRIPTION	RECORD TYPE	CONF	VITAL	ARCH	RETENTION	REMARKS	
HEALTH SERVICES	PUBLIC HEALTH - ENVIRONMENTAL HEALTH	PH	EH	010	HAZARDOUS MATERIAL (CUPA) FILES (PRIOR TO 1999)	HAZARDOUS MATERIAL FILES MANAGED BY SONOMA COUNTY ENVIRONMENTAL HEALTH. TYPICAL DOCUMENT TYPES: BUSINESS SITE PLANS, TANNER HAZ MAT COMMISSION FILES AND UNDERGROUND STORAGE TANKS.	OFF		V	A	PERMANENT	PROGRAM MANAGEMENT TRANSFERRED TO FIRE & EMERGENCY SERVICES IN 1999. IF DEPT. NO LONGER WANTS TO RETAIN RECORDS, SEND TO CO. ARCHIVES FOR PERM. RETENTION.
HEALTH SERVICES	PUBLIC HEALTH - ENVIRONMENTAL HEALTH	PH	EH	020	LOP/LEAKING UNDERGROUND STORAGE TANKS	ACTIVE AND INACTIVE TANKS OR CONTAMINATED SOIL SITES AS A RESULT OF REMOVED/LEAKING STORAGE TANKS. MONITORS REPAIRS, INSTALLATION, REMOVAL AND PROGRESS AS PER CLEAN UP PROGRAM (SB2004). TYPICAL DOCUMENT TYPES: PERMITS, APPLICATIONS, PETITIONS, TIMESHEETS, LAB RESULTS, ACTIVITY LOGS, CORRESPONDENCE, INSPECTIONS, FEES.	OFF		V	A	PERMANENT	PORTIONS OF FILE KEPT AT NORTH COAST WATER QUALITY CONTROL BOARD. SITES MEETING THE THRESHOLD FOR STATE MONITORING ARE KNOWN AS LOP FILES. IF DEPT. NO LONGER WANTS TO RETAIN RECORDS, SEND TO CO. ARCHIVES FOR PERM. RETENTION.
HEALTH SERVICES	PUBLIC HEALTH - ENVIRONMENTAL HEALTH	PH	EH	030	MONITORING WELL FILES	CONTAINS PERMITS, DRILLING AND INSPECTION INFORMATION PERTINENT TO RECORDING UNDERGROUND CONTAMINATION. TYPICAL DOCUMENT TYPES: PERMIT APPLICATIONS, INVOICES, LOGS, INSPECTIONS REPORTS AND CORRESPONDENCE.	OFF		V	A	PERMANENT	IF DEPARTMENT NO LONGER WANTS TO RETAIN RECORDS, SEND TO THE COUNTY ARCHIVES FOR PERMANENT RETENTION. CA WATER CODE 13752 GOVERNS WHETHER WELL LOGS ARE CONFIDENTIAL OR NOT. PLEASE REVIEW CODE PRIOR TO DESTRUCTION OR DISCLOSURE.
HEALTH SERVICES	PUBLIC HEALTH - ENVIRONMENTAL HEALTH	PH	EH	040	NON-PERMITTED FACILITY PLAN CHECK FILES	APPROVED DESIGN RECORDS FOR FACILITIES THAT DO NOT BECOME PERMITTED FACILITIES. TYPICAL DOCUMENT TYPES: SUBMITTED PLANS, APPROVALS, APPLICATIONS AND MODIFICATIONS, CORRESPONDENCE.	OFF				AI + 2Y	ALSO KNOWN AS PLAN REVIEW FILES. HOLD FOR 2 YEARS PAST ISSUANCE OF APPROVAL.
HEALTH SERVICES	PUBLIC HEALTH - ENVIRONMENTAL HEALTH	PH	EH	050	PERMIT FILES	PERMIT FILES AND INSPECTION REPORTS FOR: FOOD FACILITIES, PUBLIC POOLS, DAIRIES, ORGANIZED CAMPS, DETENTION FACILITIES, BODY ART, SCHOOLS, STATE SMALLWATER SYSTEMS, PUMPER TRUCKS, MEDICAL WASTE, LIQUID WASTE, REFUSE COLLECTION, CANNABIS, WASTE TIRE, ETC. TYPICAL DOCUMENT TYPES: PERMITS, BILLING CARD, REQ. FOR SVCS. PLAN CHECKS, INSPECTIONS, TEST RESULTS COMPLAINTS ETC.	OFF	C			5Y	COMPLAINTS ARE CONFIDENTIAL. THESE FILES HAVE A ROLLING 5Y RETENTION PERIOD.
HEALTH SERVICES	PUBLIC HEALTH - ENVIRONMENTAL HEALTH	PH	EH	060	PERMIT FILES - APPLICATIONS	PERMIT APPLICATIONS FOR PROGRAMS ADMINISTERED BY ENVIRONMENTAL HEALTH SUCH AS: FOOD FACILITIES, PUBLIC POOLS, DAIRIES, ORGANIZED CAMPS, DETENTION FACILITIES, BODY ART, SCHOOLS, STATE SMALLWATER SYSTEMS, PUMPER TRUCKS, MEDICAL WASTE, REFUSE COLLECTION, ETC. TYPICAL DOCUMENT TYPES: APPLICATION.	OFF				SUP/OBS +5Y	DOES NOT INCLUDE MONITORING WELLS OR SOLID WASTE.
HEALTH SERVICES	PUBLIC HEALTH - ENVIRONMENTAL HEALTH	PH	EH	070	PERMIT FILES - FINAL PLANS	FINAL PLANS FOR PERMIT PROGRAMS ADMINISTERED BY THE DEPARTMENT OF HEALTH. TYPICAL DOCUMENT TYPES: FACILITY PLANS, SPEC SHEETS	OFF				SUP/OBS	RECORDS ARE SUPERSEDED WHEN NEW DESIGN RECORDS ARE RECEIVED AND OBSOLETE 5Y AFTER CLOSE OF FACILITY.

DEPARTMENT	DIVISION	ITEM #			TITLE	DESCRIPTION	RECORD TYPE	CONF	VITAL	ARCH	RETENTION	REMARKS
HEALTH SERVICES	PUBLIC HEALTH - ENVIRONMENTAL HEALTH	PH	EH	080	PROPOSITION 65 FILES	MEDIA REPORTING AS A RESULT OF AN IDENTIFIED PROP 65 SUBSTANCE RELEASE. TYPICAL DOCUMENT TYPES: INCIDENT REPORTS, CORRESPONDENCE, CASE REPORTS.	OFF		V		CAL + 10Y	
HEALTH SERVICES	PUBLIC HEALTH - ENVIRONMENTAL HEALTH	PH	EH	090	RIGHT OF ENTRY (ROE) AND DEBRIS MANAGEMENT	RIGHT OF ENTRY ACCESS OR OPT OUT FORMS, INSURANCE DOCUMENTATION, ENVIRONMENTAL SITE/SOILS SAMPLES AND TESTING, COMPLETION LETTERS OR CERTIFICATIONS INDICATING THE CLEARANCE OF PROPERTY IS COMPLETED, NON-COMPLIANCE/CODE ENFORCEMENT. ADDITIONAL DOCUMENTS MAY INCLUDE: OWNER IDENTIFICATION, TRUST RECORDS, CORRESPONDENCE.	OFF	C	V	A	PERMANENT	ALL OWNER AND INSURANCE INFORMATION IS CONFIDENTIAL. IF DEPT. NO LONGER WANTS TO RETAIN RECORDS, SEND TO CO. ARCHIVES FOR PERM. RETENTION.
HEALTH SERVICES	PUBLIC HEALTH - ENVIRONMENTAL HEALTH	PH	EH	100	SOLID WASTE FILES	RECORDS STATUS OF SOLID WASTE FACILITIES, IDENTIFYING VOLUME AND TYPE OF WASTE. TYPICAL DOCUMENT TYPES: CORRESPONDENCE, PLANS, MAPS, INVOICES, INSPECTION REPORTS AND REQUEST FORMS.	OFF			A	PERMANENT	IF DEPT. NO LONGER WANTS TO RETAIN RECORDS, SEND TO CO. ARCHIVES FOR PERM. RETENTION.
HEALTH SERVICES	PUBLIC HEALTH - ENVIRONMENTAL HEALTH	PH	EH	110	SOLID WASTE/GARBAGE COMPLAINTS	RECORDS PUBLIC COMPLAINTS ABOUT GARBAGE HEALTH HAZARDS IN VIOLATION OF HEALTH CODE. TYPICAL DOCUMENT TYPES: INSPECTION REPORTS, COMPLAINTS, CORRESPONDENCE.	OFF				FY + 5Y	ANY COMPLAINTS THAT RESULT IN LITIGATION WOULD BE RETAINED AS CASE FILES BY THE DISTRICT ATTORNEY'S OFFICE

RETENTION SCHEDULE FOR THE DEPARTMENT OF HEALTH SERVICES - PUBLIC HEALTH - ANIMAL SERVICES												
DEPARTMENT	DIVISION	ITEM #			TITLE	DESCRIPTION	RECORD TYPE	CONF	VITAL	ARCH	RETENTION	REMARKS
HEALTH SERVICES	PH - ANIMAL SERVICES	PH	AS	010	FIELD RECORDS	RECORDS THAT DOCUMENT FIELD OPERATIONS OF ANIMAL SERVICES SUCH AS ABATEMENTS, BITE REPORTS, LAW ENFORCEMENT ACTIVITIES. TYPICAL DOCUMENTS INCLUDE: ABATEMENT ORDERS, REPORTS, PETITIONS, PHOTOS, LAB RECORDS, COMPLAINTS, SUMMONS, COURT MATERIAL, SERVICE REQUESTS, RIDE ALONG FORMS AND WAIVERS.	OFF				AC+3Y	HOLD 1 YR PAST STATUTE OF LIMITATIONS ON PERSONAL INJURY, CURRENTLY GOVERNED BY CCP 335.1
HEALTH SERVICES	PH - ANIMAL SERVICES	PH	AS	020	SHELTER - MEDICAL	RECORDS PERMITTING USE OF CONTROLLED SUBSTANCES AND DOCUMENTING ANIMAL HEALTH/TREATMENT. TYPICAL DOCUMENTS INCLUDE: REGISTRATION CERTIFICATE, APPLICATION, EUTHANASIA RECORD, SUPPLY TRACKING. MEDICAL RECORDS.	OFF				AC+3Y	MEDICAL RECORDS ARE GOVERNED BY CCR 2032.3(B)
HEALTH SERVICES	PH - ANIMAL SERVICES	PH	AS	030	SHELTER - OPS	OPERATIONAL RECORDS OF THE SERVICES PROVIDED BY THE ANIMAL SHELTER SUCH AS LICENSING, IMPOUNDS AND MEDICAL TREATMENT. TYPICAL DOCUMENTS INCLUDE: LICENSE REGISTRATIONS, IMPOUND AND RELEASE RECORDS, RELINQUISHMENTS, ADOPTIONS, LOST/FOUND,	OFF				AE+3Y	EVENT IS LIFE OF ANIMAL OR DISCHARGE/ADOPTION
HEALTH SERVICES	PH - ANIMAL SERVICES	PH	AS	040	KENNEL FILES	REGISTRATION AND INSPECTION RECORDS FOR HOBBY AND COMMERCIAL KENNELS, PET SHOPS. TYPICAL DOCUMENTS INCLUDE: KENNEL/PET SHOP APPLICATION, INSPECTIONS, CORRESPONDENCE, LICENSES.	OFF				LIFE	RETAIN RECORDS FOR THE LIFE OF THE KENNEL OR PET SHOP REGARDLESS OF OWNERSHIP.

**COUNTY OF SONOMA
REQUEST FOR APPROVAL OF RECORDS RETENTION SCHEDULE**

The Board of Supervisors is requested to approve the attached records retention schedule(s); approval constitutes continuing authority for the proper disposal of the records listed.

DEPARTMENT: Health Services	DIVISION: Public Health
SECTION: Consumer Protection & Environmental Health	SCHEDULE NO: 3

1. COUNTY RECORDS MANAGEMENT REVIEW

The Records Manager of the County of Sonoma has reviewed the attached schedule(s) for compliance with countywide standards and policies and conformance with accepted records management practices.

SIGNATURE <i>Carolyn Staats</i>	TITLE <i>Records Manager</i>	DATE <i>7-30-18</i>
PRINT/TYPED NAME <i>Carolyn Staats</i>		

2. DEPARTMENTAL REVIEW

I have reviewed the attached records retention schedule(s) which has/have been prepared after careful examination of all records with regard to operating, administrative, legal, fiscal, or historical value, as well as to application of appropriate county, state and federal rules, ordinances, regulations and/or statutes governing records retention.

DEPARTMENT HEAD SIGNATURE <i>Wendy Sauer</i>	TITLE <i>Compliance Officer</i>	DATE <i>09/05/18</i>
PRINT/TYPED NAME		
DIVISION HEAD SIGNATURE <i>Christine Sosko</i>	TITLE <i>Director of Env. Health</i>	DATE <i>9-25-17</i>
PRINT/TYPED NAME <i>Christine Sosko</i>		

3. COUNTY COUNSEL REVIEW

As County Counsel, I have reviewed the retention periods assigned to records on the attached schedule(s). I hereby certify that I am the lawful head, or that I am authorized to act for the head, of the Office of County Counsel in matters pertaining to records disposal.

SIGNATURE <i>Jeff Erick</i>	TITLE <i>County Counsel</i>	DATE <i>3/19/18</i>
PRINT/TYPED NAME <i>JEFF ERICK</i>		

4. AUDITOR-CONTROLLER/TREASURER-TAX COLLECTOR REVIEW

As County Auditor-Controller/Treasurer-Tax Collector, I have reviewed the retention periods assigned to records on the attached schedule(s) to determine their conformance with audit requirements.

SIGNATURE <i>E. de Ren</i>	TITLE <i>ACTTC</i>	DATE <i>7/13/18</i>
PRINT/TYPED NAME		

5. ARCHIVAL REVIEW

As Chairperson of the Sonoma County Historical Records Commission, I have reviewed the schedule(s) and have identified those items, which, in my judgment, have archival, historical or research value.

SIGNATURE <i>Katherine J. Rinhardt</i>	TITLE <i>Chair</i>	DATE <i>3/13/18</i>
PRINT/TYPED NAME <i>Katherine J. Rinhardt</i>		

6. BOARD OF SUPERVISORS APPROVAL

THE ATTACHED RECORDS RETENTION SCHEDULE(S) IS/ARE APPROVED PER

RESOLUTION NUMBER: _____

DATE: _____

**COUNTY OF SONOMA
REQUEST FOR APPROVAL OF RECORDS RETENTION SCHEDULE**

The Board of Supervisors is requested to approve the attached records retention schedule(s); approval constitutes continuing authority for the proper disposal of the records listed.

DEPARTMENT: Health Services	DIVISION: Public Health
SECTION: Animal Services	SCHEDULE NO: 3

1. COUNTY RECORDS MANAGEMENT REVIEW

The Records Manager of the County of Sonoma has reviewed the attached schedule(s) for compliance with countywide standards and policies and conformance with accepted records management practices.

SIGNATURE <i>Carolyn M. Staats</i>	TITLE <i>Sr. Records Manager</i>	DATE <i>7-30-18</i>
PRINT/TYPED NAME <i>Carolyn Staats</i>		

2. DEPARTMENTAL REVIEW

I have reviewed the attached records retention schedule(s) which has/have been prepared after careful examination of all records with regard to operating, administrative, legal, fiscal, or historical value, as well as to application of appropriate county, state and federal rules, ordinances, regulations and/or statutes governing records retention.

DEPARTMENT HEAD SIGNATURE <i>Wendy Sanders</i>	TITLE <i>Compliance Officer</i>	DATE <i>03/05/18</i>
PRINT/TYPED NAME <i>Wendy Sanders</i>		
DIVISION HEAD SIGNATURE <i>John Skeel</i>	TITLE <i>Animal Services Director</i>	DATE <i>2/20/17</i>
PRINT/TYPED NAME <i>John Skeel</i>		

3. COUNTY COUNSEL REVIEW

As County Counsel, I have reviewed the retention periods assigned to records on the attached schedule(s). I hereby certify that I am the lawful head, or that I am authorized to act for the head, of the Office of County Counsel in matters pertaining to records disposal.

SIGNATURE <i>Jeff Beck</i>	TITLE <i>County Counsel</i>	DATE <i>3/19/18</i>
PRINT/TYPED NAME <i>Jeff Beck</i>		

4. AUDITOR-CONTROLLER/TREASURER-TAX COLLECTOR REVIEW

As County Auditor-Controller/Treasurer-Tax Collector, I have reviewed the retention periods assigned to records on the attached schedule(s) to determine their conformance with audit requirements.

SIGNATURE <i>E. Carter</i>	TITLE <i>ACTTC</i>	DATE <i>7/13/18</i>
PRINT/TYPED NAME		

5. ARCHIVAL REVIEW

As Chairperson of the Sonoma County Historical Records Commission, I have reviewed the schedule(s) and have identified those items, which, in my judgment, have archival, historical or research value.

SIGNATURE <i>Katherine J. Rinhardt</i>	TITLE <i>Chair</i>	DATE <i>3/13/18</i>
PRINT/TYPED NAME <i>Katherine J. Rinhardt</i>		

6. BOARD OF SUPERVISORS APPROVAL

THE ATTACHED RECORDS RETENTION SCHEDULE(S) IS/ARE APPROVED PER
RESOLUTION NUMBER: _____
DATE: _____



County of Sonoma Agenda Item Summary Report

Clerk of the Board
575 Administration Drive
Santa Rosa, CA 95403

Agenda Item Number: 32
(This Section for use by Clerk of the Board Only.)

To: Board of Supervisors

Board Agenda Date: November 13, 2018

Vote Requirement: Majority

Department or Agency Name(s): Permit Sonoma

Staff Name and Phone Number:

Georgia McDaniel 565-4919

Supervisorial District(s):

All

Title: Contract Extension for Capacity Threshold Study for Dry Creek Valley and Sonoma Valley

Recommended Actions:

- (1) Authorize the Director of Permit Sonoma to execute an amendment to an agreement with Omni Means (now a GHD Company) for Phase IV of the Dry Creek Valley, Westside Road and Sonoma Valley Capacity Threshold Study increasing the contract amount by \$67,195 resulting in a new not-to-exceed amount of \$167,188.
- (2) Authorize the Director of Permit Sonoma to execute an Assignment, Novation and Consent Agreement by and among Omni Means Engineering Solutions, A California Corporation ("Assignor"), GHD, a California Corporation ("Assignee"), and the County of Sonoma, a political subdivision of the State of California ("County") for the Dry Creek Valley, Westside Road and Sonoma Valley Capacity Threshold Study agreement.
- (3) Authorize the Director of Permit Sonoma to execute an Assignment, Novation and Consent Agreement by and among Omni Means Engineering Solutions, A California Corporation ("Assignor"), GHD, a California Corporation ("Assignee"), and the County of Sonoma, a political subdivision of the State of California ("County") for the Traffic Study Peer Reviews agreement.

Executive Summary:

The County of Sonoma retained Omni-Means in August 2017 to conduct the Dry Creek Valley and Sonoma Valley Capacity Threshold Study (Traffic Study) for the areas with local concentrations of winery events in of Dry Creek Valley, Westside Road and Sonoma Valley. The Traffic Study is broken into phases. The Phase I, Background Conditions Report, is complete and includes in-depth reviews of previous analyses, existing literature, applicable safety and capacity standards, and all other available transportation information for Dry Creek Valley and Sonoma Valley. Phases II and III include an evaluation of roadway capacity and level of service analysis for Dry Creek Valley, Westside Road and Sonoma Valley, respectively.

During the Phase III, it was determined that the limited available data, particularly for Sonoma Valley, made it difficult to draw conclusions and that additional data was needed. The Director of Permit

Sonoma inquired about using innovative methods for gathering traffic data. In response, Omni Means/GHD identified a newly released dataset: NPMRDS – National Performance Management Research Data Set. The data base is a combination of data from FHWA sensors installed in roads, GPS plus cell phone blue tooth and wi-fi data. The data covers only state highways. State Highways 12, 116, 121 and 37 are covered in Sonoma Valley, but some data for other streets may be available.

In July 2018, following the proper procedure, Permit Sonoma requested access to the NPMRDS database through the Metropolitan Transportation Commission (MTC). Since an entire year of data was available, Permit Sonoma obtained data from June 2017 to May 2018 at no cost. Omni Means/GHD has possession of the data. Permit Sonoma is requesting approval to proceed with a Phase IV that will include obtaining additional NPMRDS data from May 2018 to October 2018 plus analysis of all of the NPMRDS data from June 17 to October 2018, updating the LOS analysis and expansion of the findings into the Traffic Study by Omni Means/GHD.

Upon execution of the amendment to the agreement on November 13, 2018, Omni Means/GHD will proceed with Phase IV. Omni Means/GHD will complete the Dry Creek Valley Traffic Study in 8-10 weeks from that date or sometime in the time period of January 4-18, 2019. The Sonoma Valley Traffic Study will be completed 12-14 weeks from that date or sometime in the time period of February 1-15, 2019. Both traffic studies will be submitted to Permit Sonoma for review.

After the County entered into the agreement with Omni Means for the preparation of the Dry Creek Valley, Westside Road and Sonoma Valley Capacity Threshold Study and another agreement for peer review of traffic studies, Omni Means sold all of its business operations to GHD, including its rights under these two agreements. Since Omni Means has consented to the assignment of all of Omni Means rights and obligations under these two agreements to GHD, the County must provide its written consent. Therefore, the requests to authorize the Director of Permit Sonoma to execute the Assignment, Novation and Consent Agreements for these two agreements are included in the recommended actions.

Discussion:

The Dry Creek Valley and Sonoma Valley Capacity Threshold Studies are part of the policy analysis process in these two areas of local concentration for winery events. During Phases II and III, traditional traffic counts were taken at specific roadway segments and intersections for non-industrywide winery event weekends to establish an average base weekend condition and on certain industry-wide event weekends. Service levels were quantified and comparative analysis performed.

NPMRDS provides a much broader spectrum of data than the limited traffic counts upon which to draw conclusions. Utilizing NPMRDS data allows the user to (a) choose event weekends, non-event weekends and week days; (b) make correlations between events and prepare comparisons regarding weekend events; (c) compare the speeds on event weekends and non-event weekends; (d) tie events to impacts; and/or (e) calculate LOS and relate the data back to LOS. The impacts of cycling events and NASCAR races can also be compared. The greater amount of data to be analyzed and presented in the Sonoma Valley study will allow the County to respond better to traffic concerns of the Sonoma Valley stakeholders and Valley of the Moon Alliance (VOTMA). Since the data is free, data was downloaded for the Dry Creek Area as well to supplement that current analysis. The current data will supplement the new data in both studies.

Staff recommends that NPMRDS data from June 2017 to October 2018 be included in the contract since the complex-fires in October 2017 had an effect on winery events and the number of tourists visiting Sonoma County. They also had an effect upon typical travel patterns for Sonoma County residents. The expanded analysis and findings in the Dry Creek Valley and Sonoma Valley Capacity Threshold Studies will provide the Board with greater knowledge due to this more comprehensive approach.

Prior Board Actions:

- July 12, 2016 – Board Study Session on winery events
- December 9, 2014 – Approve the Comprehensive Planning work Plan
- September 10, 1996 – Adopt resolution of intention to allow limited food service
- March 9, 1993 – Adopt Ordinance updating Zoning Code to reflect new policies for agricultural promotion
- March 23, 1989 – Adopt General Plan including new Agricultural Resources Element

Strategic Plan Alignment Goal 2: Economic and Environmental Stewardship

Agricultural promotional activities and events are considered essential to the economic viability of the wine industry. These activities can also impact neighborhoods as well as agricultural operations and create potential conflicts with incompatible uses. The goal of existing General Plan policies is to balance these competing interests and preserve agricultural lands while maintaining rural character of the area.

Fiscal Summary

Expenditures	FY 18-19 Adopted	FY 19-20 Projected	FY 20-21 Projected
Budgeted Expenses	\$167,188		
Additional Appropriation Requested			
Total Expenditures	\$167,188		

Funding Sources

General Fund/WA GF			
State/Federal			
General Plan Administrative Fee/Other	\$167,188		
Use of Fund Balance			
Contingencies			
Total Sources	\$167,188		

Narrative Explanation of Fiscal Impacts:

The original contract for \$99,993 was funded by the General Plan Administrative Fee as it implements a program of the General Plan. There is sufficient appropriations in the General Plan Administrative Fee to cover the increased contract cost.

Staffing Impacts			
Position Title (Payroll Classification)	Monthly Salary Range (A – I Step)	Additions (Number)	Deletions (Number)
Narrative Explanation of Staffing Impacts (If Required):			
Attachments:			
Attachment A: First Amendment to Professional Services Agreement Attachment B: Assignment, Novation and Consent Agreement for the Dry Creek Valley, Westside Road and Sonoma Valley Capacity Threshold Study Agreement Attachment C: Assignment, Novation and Consent Agreement for the Traffic Study Peer Reviews Agreement			
Related Items “On File” with the Clerk of the Board:			

**FIRST AMENDMENT
TO
PROFESSIONAL SERVICES AGREEMENT**

This First Amendment ("Amendment"), dated as of November 13, 2018, is by and between the County of Sonoma, a political subdivision of the State of California ("County"), and GHD, Inc., a California corporation, hereinafter referred to as ("Consultant").

RECITALS

WHEREAS, County and Omni Means Engineering Solutions (Assignor) entered into that certain Agreement, dated August 18, 2017, for winery events traffic analysis; and

WHEREAS, County, Assignor, and Consultant, entered into Assignment, Novation, and Consent Agreement dated November 13, 2018 wherein Consultant consented to the assignment of all of Assignor's rights and obligations under the Agreement; and

WHEREAS County and Consultant now seek to increase the amount not to exceed to an amount of \$167,188, an increase of \$67,195.

WHEREAS, County and Consultant desire to amend the Agreement to provide additional services related to Dry Creek Valley and Sonoma Valley as detailed in the exhibits.

NOW, THEREFORE, for good and valuable consideration, the receipt and sufficiency of which are hereby acknowledged, the parties hereto agree as follows:

AGREEMENT

1. Article 2, Payment, Paragraph 1, shall be amended to read as follows:

2. Payment.

- For all services and incidental costs required hereunder, Consultant shall be paid on a time and material/expense basis in accordance with the budget set forth in Exhibit B, provided, however, that total payments to Consultant shall not exceed \$167,188, without the prior written approval of County. Consultant shall submit its bills in arrears on a monthly basis in a form approved by County's Auditor and the Head of the County Department receiving the services. The bills shall show or include: (i) the task(s) performed; (ii) the time in quarter hours devoted to the task(s); (iii) the hourly rate or rates of the persons performing the task(s); and (iv) copies of receipts for reimbursable materials/expenses, if any. Expenses not expressly authorized by the Agreement shall not be reimbursed.

2. Exhibit A is rescinded and replaced with the new Exhibit A, attached.
3. Exhibit B is rescinded and replaced with the new Exhibit B, attached.

4. Except to the extent the Agreement is specifically amended or supplemented hereby, the Agreement, together with exhibits is, and shall continue to be, in full force and effect as originally executed, and nothing contained herein shall, or shall be construed to modify, invalidate or otherwise affect any provision of the Agreement or any right of County arising thereunder.

3. This Amendment shall be governed by and construed under the internal laws of the state of California, and any action to enforce the terms of this Amendment or for the breach thereof shall be brought and tried in the County of Sonoma.

COUNTY AND CONSULTANT HAVE CAREFULLY READ AND REVIEWED THIS AMENDMENT AND EACH TERM AND PROVISION CONTAINED HEREIN AND, BY EXECUTION OF THIS AMENDMENT, SHOW THEIR INFORMED AND VOLUNTARY CONSENT THERETO.

IN WITNESS WHEREOF, the parties hereto have executed this Amendment as of the effective date.

**CONSULTANT:
GHD, Inc.**

By: _____

Name: _____

Title: _____

Date: _____

COUNTY OF SONOMA:

**CERTIFICATES OF INSURANCE ON
FILE WITH AND APPROVED AS TO
SUBSTANCE FOR COUNTY:**

By: _____
Director, Permit and Resource Management

Date: _____

**APPROVED AS TO FORM FOR
COUNTY:**

By: _____
County Counsel

Date: _____

By: _____
Director, Permit and Resource Management

Date: _____

Exhibit A: SCOPE OF WORK

Provide traffic analysis for Dry Creek Valley and Westside Road plus Sonoma Valley.

WORK TASKS:

Dry Creek Valley and Sonoma Valley Capacity Threshold Study

- Phase I - Dry Creek Valley and Sonoma Valley Background Conditions Report
- Phase II - Dry Creek Valley Capacity Threshold Study
- Phase III - Sonoma Valley Capacity Threshold Study

PHASE I - DRY CREEK VALLEY AND SONOMA VALLEY BACKGROUND CONDITIONS REPORT

Task 1 Review Background Materials

With the help of County staff, Omni-Means will gather and review all relevant background materials to the study areas. Key issues from these materials will be summarized in the Background Conditions Report. These materials will include the following documents and data sources:

- Existing Traffic Count Information
- Sonoma County Winery Database
- Winery event information (including industry-wide events)
- Major area bicycle events and routes, as available
- Existing County roadway classifications and standards
- Existing County roadway policies (General Plan, municipal code, local ordinance, other adopted plans)
- Existing County practices for winery trip generation estimates
- Recent area traffic studies, including TJKM Dry Creek Valley Association study and Seaton Winery
- 5-year SWITRS collision summary

The above information will be summarized in maps and tables, as appropriate. As additional pertinent information is revealed during the course of the background materials review, additional documents may be added.

Task 2 Literature Review

Having established the existing background conditions in Task 1, Task 2 will explore available literature relevant to both winery destination communities and rural roadway safety and capacity standards.

Specifically, Omni-Means will seek winery and wine event trip generation research from other Counties and regions in the State to ensure Sonoma County's trip generation rates are appropriate and current with industry standards. We will also review available vehicle occupancy data for regular and special event winery trips, as available from readily accessible sources.

Omni-Means will also review other counties' safety and capacity standards in rural settings, specifically with respect to narrow roadways and substandard design features

(sight distance, cross section, design speed, etc.).

Task 3 Policy and Ordinance Options

Based on the results of Tasks 1 and 2, Omni-Means will develop a list of policies, best practices, and/or ordinances the County could consider, applicable to rural roadway characteristics, shared road use between cyclists and motorists, and winery specific event traffic. Phase 1 will come short of providing recommendations; policy recommendations will be included in Phase 2 of this study.

Task 4 Report Preparation

Omni-Means will prepare a Draft Background Conditions Report for County staff to review, incorporating the work in Tasks 1 through 3. Following County review, Omni-Means will schedule a conference call to discuss comments, concerns, and questions, before incorporating County edits and finalizing the report.

PHASE II - DRY CREEK VALLEY CAPACITY THRESHOLD STUDY

Task 5 Existing Conditions Analysis

5.1 Roadway Capacity and Level of Service

Omni-Means will quantify existing roadway level of service using both the County supplied traffic data and the newly obtained Winter Wineland (January 2016) traffic data. This will provide level of service for both average weekday and weekend conditions, and during a "peak use" scenario, such as an industry-wide event weekend.

Service levels will be quantified using daily roadway volume-to-capacity tables based on the County roads' rural characteristics. We will also evaluate roadway segments using HCS software on a peak hour basis, a direct implementation of Highway Capacity Manual 2010 methodologies.

Lastly, a rural neighborhood traffic threshold will be developed, similar to many communities' traffic calming thresholds, in order to determine at what daily traffic level a neighborhood impact is created. While not strictly capacity-based, this threshold will be used to evaluate whether existing conditions are approach, exceed, or fall short of a reasonable rural neighborhood collector or local street standard.

5.2 Safety Analysis

Omni-Means will evaluate the study roadway segments against the County's existing roadway design standards and other industry standards to identify existing safety deficiencies. We will also analyze the SWITRS data on the study roadway segments and look for any correlation between non-motorized (especially cyclist) collisions with times of the year that experience high winery activity, including harvest season and other industry-wide events.

Task 6 "Cumulative" Conditions Analysis

For the purposes of this study, "Cumulative" conditions refer to a scenario in which all remaining undeveloped winery land is built out. This condition will be analyzed as a "worst-case" scenario in which a number of wineries, based on County direction, are

assumed to be open and participating in an industry-wide event. Traffic will be forecast for this hypothetical scenario by developing a reasonable trip rate for existing wineries on industry-wide event days, and extrapolating that rate with the assumed number of new wineries.

Following development of this forecast, a "Cumulative" conditions analysis will be run for roadway capacity, level-of-service, and safety, similar to the analyses performed in Tasks 5.1 through 5.3.

Task 7 Study Preparation

Omni-Means will prepare a Draft Dry Creek Valley Capacity Threshold Study for County staff to review, incorporating the work in Tasks 1 through 3 (Background Conditions Report) and Tasks 5 through 6. Following County review, Omni-Means will schedule a conference call to discuss comments, concerns, and questions, before incorporating County edits and finalizing the report.

Task	Task Description	Project Schedule												Traffic Engineer	Project Manager	Project Planner	Total Hours	Total Cost	
		Week 1	Week 2	Week 3	Week 4	Week 5	Week 6 (Agency Review)	Week 7 (Agency Review)	Week 8	Week 9	Week 10	Week 11	Week 12						
Phase 0 Project Management, Coordination & Meetings												\$188	\$144	\$90					
	General Project Management	■	■	■	■	■	■	■	■	■	■	■	■	■	4	8		12	\$1,904
Phase I Dry Creek Valley & Sonoma Valley Background Conditions Report																			
Task 1	Review Background Materials	■	■	■	■											2	16	18	\$1,728
Task 2	Literature Review	■	■	■	■											2	16	18	\$1,728
Task 3	Policy and Ordinance Options			■	■	■										4	20	24	\$2,376
Task 4	Report Preparation				■	■										4	24	28	\$2,736
Phase II Dry Creek Valley Capacity Threshold Study																			
Task 5	Existing Conditions Analysis																		
5.1	Roadway Capacity and Level of Service							■	■	■						2	40	42	\$3,888
5.2	Safety Analysis							■	■	■						2	24	26	\$2,448
Task 6	Cumulative Conditions Analysis									■	■	■				2	24	26	\$2,448
Task 7	Study Preparation									■	■	■				4	36	40	\$3,816
Phase III Sonoma Valley Capacity Threshold Study (TBD)																			
												4	30	200	234	\$23,072			
													\$752	\$4,320	\$18,000	\$23,072			

Phase II EWA #1

		Project Manager	Project Planner	Traffic Counts	Total Hours	Total Cost
Task	Task Description	\$144	\$90			
Phase II Dry Creek Valley Capacity Threshold Study (Extra Work Authorization)						
Task 5	Existing Conditions Analysis					
5.1	Traffic Data Collection	1	2	\$1,485	3	\$1,809
5.2	Roadway Capacity and Level of Service	1	4		5	\$504
Task 7	Study Preparation	2	4		6	\$648
Phase II Extra Work Authorization Subtotal					14	\$2,961

Phase II EWA #2

		Week 1	Week 2	Principal	Project Planner	Total Hours	Total Cost
Task Schedule	Task Description	Project		\$227	\$90		
Phase II Dry Creek Valley Capacity Threshold Study (Extra Work Authorization)							
Task 8	Report Finalization and Response to Comments			8	32	40	\$4,696
							\$4,696
						\$1,816	\$2,980

Phase II EWA #4

Dry Creek Valley Capacity Threshold Study (EWA #4)	COMPENSATION
Traffic Counts on four roadway segment during Off Peak Season Non-Industry-wide event weekend	\$720.00
Comparative analysis of Off-Peak Season non-industry-wide event analysis to be incorporated into the Dry Creek Capacity Threshold Study	\$5000.00
	\$0.00
TOTAL	\$5720.00

Phase II EWA #5

DESCRIPTION OF ADDITIONAL SERVICES	COMPENSATION
Obtain daily traffic counts on nine (9) roadway segments in Dry Creek Valley consistent with existing draft study.	\$1,500.00
Expand the current Dry Creek Valley Capacity Threshold Study Draft Report to include the additional traffic counts and comparative analysis.	\$4,500.00
	\$0.00
TOTAL	\$6,000.00

PHASE III - SONOMA VALLEY CAPACITY THRESHOLD STUDY

Task 8 Existing Conditions Analysis

Roadway Capacity and Level of Service

Omni-Means will quantify existing roadway level of service using weekend roadway segment counts collected at eighteen (18) locations this Spring during a non-industrywide winery event weekend to establish an average base weekend condition. This will provide level of service for a typical weekend, which still experience significant visitor traffic. As an option to be considered later, might be to obtain a Summer or Fall "peak use" scenario, such as during an industry-wide event weekend, which will place additional strain on existing County roadway facilities. The thought behind obtaining a typical weekend condition is to establish a baseline, for which physical improvements might need to be constructed to support such "typical" travel conditions. Then, if desired, identify that peak level of traffic that more cost effective programmatic solutions might best address.

Service levels will be quantified using daily roadway volume-to-capacity tables based on the County roads' rural characteristics. We will also evaluate roadway segments using HCS software on a peak hour basis, a direct implementation of Highway Capacity Manual 2010 methodologies.

Lastly, a rural neighborhood traffic threshold will be developed, similar to many communities' traffic calming thresholds, in order to determine at what daily traffic level

a neighborhood impact is created. While not strictly capacity-based, this threshold will be used to evaluate whether existing conditions approach, exceed, or fall short of a reasonable rural neighborhood collector or local street standard.

Intersection Capacity and Level of Service

Omni-Means will also quantify existing intersection levels of service using weekend counts collected at thirteen (13) intersections this Spring during a non-industry-wide winery event. This will provide a more refined quantification of level-of-service conditions than is achieved through roadway segment analysis for the Sonoma Valley Capacity Threshold Study, and may identify capacity constraints that could be missed using only a segment analysis. In review of available weekend traffic counts obtained from project specific traffic studies, five (5) of the thirteen (13) locations did have available weekend traffic counts that were generally collected in the Fall of 2015 and 2016. However, although these counts might be considered useable, the additional information gained about seasonal fluctuation and obtaining more current counts is, in our opinion, worthwhile obtaining a complete 2017 traffic count dataset.

Safety Analysis

Omni-Means will evaluate the study roadway segments against the County's existing roadway design standards and other industry standards to identify existing safety deficiencies. We will also analyze the SWITRS data on the study roadway segments and look for any correlation between non-motorized (especially cyclist) collisions with times of the year that experience high winery activity, including harvest season and other industry-wide events.

Task 9 "Cumulative" Conditions Analysis

For the purposes of this study, "Cumulative" conditions refer to a scenario in which all remaining undeveloped winery land is built out. This condition will be analyzed as a "worst-case" scenario in which a number of wineries, based on County direction, are assumed to be open and participating in an industry-wide event. Traffic will be forecast for this hypothetical scenario by developing a reasonable trip rate for existing wineries on industry-wide event days, and extrapolating that rate with the assumed number of new wineries.

Following development of this forecast, a "Cumulative" conditions analysis will be run for roadway capacity, level-of-service, and safety, similar to the analyses performed in Task 8.

Task 10 Study Preparation, Project Management and Meetings

Omni-Means will prepare a Draft Sonoma Valley Capacity Threshold Study for County staff to review, incorporating the work in Phase I (Background Conditions Report) and Tasks 8 and 9.

Throughout this study process, Omni-Means will provide project management and coordination. In addition, like the Dry Creek Valley study, Omni-Means will meet with County staff to provide our study findings and recommendations. Following County review, Omni-Means will incorporate all agreed upon County edits and finalize the report. Any additional meetings or attendance at public meetings/hearings will be

attended with additional authorization.

		Project Manager	Project Planner	Traffic Counts, Direct Expenses	Total Hours	Total Cost
Task	Task Description	\$2	\$1			
Phase III Sonoma Valley Capacity Threshold Study						
Task 8	Existing Conditions Analysis					
8.1	Traffic Data Collection (Spring Non Industry-Wide	2	1	\$6,840	1	\$8,680
8.3	Roadway Capacity and Level of Service	2	4		4	\$5,060
8.4	Intersection Capacity and Level of Service	2	4		4	\$5,060
8.5	Safety Analysis	2	2		2	\$3,220
Task 9	Cumulative Conditions Analysis	2	2		2	\$3,220
Task 10	Report Preparation, Project Management /	1	4	\$260	6	\$9,460
Phase III					2	\$34,700
		\$5,980	\$21,620	\$7,100		\$34,700
Phase III Total Cost						\$34,700

+

Phase III EWA #1 Revised

DESCRIPTION OF ADDITIONAL SERVICES	COMPENSATION
Originally this budget was for a public workshop in Sonoma Valley that was then scheduled. However, the fires occurred so the workshop was cancelled. The budget amount was used for additional work on the Final Reports for the Dry Creek Valley and the Sonoma Valley Capacity Threshold Studies. Plus, additional work was conducted for the April Signature Sonoma traffic counts in Sonoma Valley. Time budgeted as follows: Principal 10 hours@\$227, Transportation Engineer 12 hours@\$115, Direct Expenses @\$200	\$3,850.00
TOTAL	\$3,850.00

Phase III EWA #2 – Additional Roadway Descriptions, Counts

DESCRIPTION OF ADDITIONAL SERVICES	COMPENSATION
<p>Additional roadway descriptions, counts and LOS analysis at the following locations:</p> <p>Roadway (Daily Counts from 4/29 – 4/30):</p> <ol style="list-style-type: none"> 1. Highway 12 north of Pythian Road . 2. Highway 12 (Broadway) north of Watmaugh Road 3. Highway 12 1 between de Mattos Road and Mangel Ranch Road (south of Ram's Gate Winery). <p>Intersection (AM and PM Peak Hour Counts on 4/29/17):</p> <ol style="list-style-type: none"> 1. Highway 12/Pythian Road <p>Time and Materials budgeted: \$825 Counts, 1hour Principal=\$227, 3 hours Engineer-\$345</p>	<p>\$1397.00</p>
TOTAL	\$1,397.00

Phase III EWA #3 – Additional Counts and LOS Analysis

DESCRIPTION OF ADDITIONAL SERVICES	COMPENSATION
<p>Obtain All Selected Roadway and Intersection Traffic Counts in both North and South Sonoma Valle during a Peak Season Wine Event Weekend starting on the afternoon of July 14th through July 16th as selected by the County. In total 24 roadway segments and 12 intersections will be counted.</p> <p>Principal 1 hours @ \$227, Engineer 2 hours @ \$114, Metro Traffic = \$7,920</p>	<p>\$\$8,375.00</p>
<p>Prepare LOS analysis and expand capacity threshold evaluation to compare peak and non-peak season, event and non-event travel conditions. Expand findings and conclusions that could help manage wine tourism travel to minimize travel impacts and enhance overall travel safety.</p> <p>Principal 12 hours @ \$227, Engineer 57 hours @ \$114</p>	<p>\$9,225.00</p>
TOTAL	\$17,597.00

PHASE IV BOTH DRY CREEK VALLEY AND SONOMA VALLEY ADDITIONAL SERVICES

In response to the Director of Permit Sonoma’s inquiry about using innovative methods for gathering traffic data, Omni Means/GHD discovered a newer method: NPMRDS – National Performance Management Research Data Set. The data base is a combination of data from FHWA sensors installed in roads, GPS plus cell phone blue tooth and wi-fi data. The data covers only state highways - State Highways 12, 116, 121 and 37 in Sonoma Valley. Some data for other streets may be available like Arnold, Broadway and Napa Street. Data allows user to a) choose event weekends, non-event weekends and week days; b) make correlations between events and prepare comparisons regarding weekend events; c) compare the speeds on event weekends and non-event weekends; plus d) tie events to impacts. Current data will supplement new data.

DESCRIPTION OF ADDITIONAL SERVICES	COMPENSATION
<p>Task A1 - Prepare an analysis of NPMRDS travel speed and travel time data in both Dry Creek Valley and Sonoma Valley. This analysis will select up to 20 days out of a year’s available data (June 2017 to May 2018) for comparative analysis between peak summer weekend with and without wine industry-wide events and non-peak summer weekend conditions. Also, weekday and weekend travel will be compared to establish average travel trending conditions throughout the year. The NPMRDS data is assumed to be obtained by Sonoma County through access provided by MTC. No cost of the data is currently assumed in this budget.</p> <p>Senior Manager 10 hours @\$227, Project Manager 30 hours@\$180, 100 hours @\$120</p>	\$19,670.00
<p>,Task A2 - Prepare an updated LOS analysis and expand capacity threshold evaluation in light of the analysis and findings from the NPMRDS data for both Dry Creek and Sonoma Valleys. Expand findings and conclusions to incorporate the correlation between the NPMRDS analysis and the roadway and intersection LOS analysis found in each draft report for both Dry Creek and Sonoma Valleys..</p> <p>Senior Manager 7 hours @\$227, Project Manager 24 hours @ \$180, Engineer 80hours @ \$120</p>	\$15,509.00
<p>Task A3 - Upon incorporation of the expanded evaluation with NPMRDS analysis, the draft reports will be processed through County PRMD to complete finalization of both the entire Dry Creek Valley Capacity Threshold Study and Sonoma Valley Capacity Threshold Study.</p> <p>Senior Manager 3 hours @ \$227, Project Manager 20 hours @ \$180, Engineer 54 hours @ \$120</p>	\$10,761.00
<p>Task A4 - Prepare for and attend four (4) Public Meetings at \$3,500 per meeting, including expenses.</p>	\$14,000.00
TOTAL COST Tasks A1 - A4	\$59,940.00

<p>OPTIONAL Task A5– Expand the analysis above to incorporate current peak summer NPMRDS data from between May 2018 to October 2018 for both within Dry Creek Valley and Sonoma Valley. The NPMDRS data will be obtained by the County and GHD will process as described in Task A1 and A2..</p> <p>Senior Manager 5 hours @ \$227, Project Manager 10 hours @ \$180, Engineer 36 hours @ \$120</p>	\$7,255.00
TOTAL COST Tasks A1 - A5 with 2018 Peak Season NPMDRS Data	\$67,195.00

Exhibit B: FEES

Hourly Rates:	Previous:	Current:
Traffic Engineer:	\$188/hour	
Project Manager:	\$144/hour	
Project Manager:	\$230/hour	
Project Planner:	\$90/hour	
Project Planner:	\$115/hour	
Principal/ Senior Manager:	\$227/hour	\$227/hour
Transportation Planner:	\$115/hour	
Project Manager		\$180/hour
Project Engineer		\$120/hour

CURRENT WORK BUDGET:

Phase 0 Project Management, Coordination & Meetings

General Project Management	\$ 1,904	
Subtotal – Phase 0		\$ 1,904

Phase I Dry Creek Valley & Sonoma Valley Background Conditions Report

Task 1 Review Background Materials	\$ 1,728	
Task 2 Literature Review	\$ 1,728	
Task 3 Policy and Ordinance Options	\$ 2,376	
Task 4 Report Preparation	\$ 2,736	
Subtotal – Phase I (Tasks 1-4)		\$ 8,568

Phase II Dry Creek Valley Capacity Threshold Study

Task 5 Existing Conditions Analysis		
5.1 Roadway Capacity and Level of Service	\$ 3,888	
5.2 Safety Analysis	\$ 2,448	
Task 6 Cumulative Conditions Analysis	\$ 2,448	
Task 7 Study Preparation	\$ 3,816	
Subtotal –Phase II (Tasks 5-7)	\$12,600	

Phase II Extra Work Authorizations (EWA)

EWA #1 - Task 5		
Task 5.1 – Traffic Data Collection (Direct Expense)	\$ 1,485	
Task 5.1 – Traffic Data Collection	\$ 324	
Task 5.2 – Roadway Capacity and Level of Service	\$ 504	
Task 7 – Study Preparation	\$ 648	
EWA #2 - Task 8 Report Finalization & Response to Comments	\$ 4,696	
EWA #4 - Traffic Counts during Off Peak Season Non-Industry-wide event	\$ 720	
- Comparative Analysis of Off-Peak Season into Study	\$ 5,000	
EWA #5 - Additional daily traffic counts in Dry Creek Valley	\$ 1,500	
- Expand Study to include additional traffic counts and analysis	\$ 4,500	
Subtotal – Phase II EWAs	\$19,377	
Subtotal – Phase II – Dry Creek Valley		\$31,977

Phase III Sonoma Valley Capacity Threshold Study

Task 8 Existing Conditions Analysis		
8.1 Traffic Data Collection Spring Non Industry-Wide (Direct Expense)	\$ 6,840	
8.1 Traffic Date Collection	\$ 1,840	
8.3 Roadway Capacity and Level of Service	\$ 5,060	
8.4 Intersection Capacity and Level of Service	\$ 5,060	
8.5 Safety Analysis	\$ 3,220	
Task 9 Cumulative Conditions Analysis	\$ 3,220	
Task 10 Report Preparation, Project Management	\$ 9,220	
Task 10 Report Preparation (Direct Expense)	\$ 260	
Subtotal - Phase III – Sonoma Valley	\$34,700	
Phase III Extra Work Authorizations (EWA)		
EWA #1 - Public Workshop	\$ 3,650	
Direct Expenses	\$ 200	
EWA #2 – Additional roadway, descriptions, counts and LOS analysis		
- Traffic Counts	\$ 825	
- LOS Analysis	\$ 572	
EWA #3 – Additional roadway, descriptions, counts and LOS analysis		
- Traffic Counts - Metro Traffic (Direct Expense)	\$ 7,920	
- Traffic counts	\$ 455	
- LOS analysis	\$ 9,225	
Subtotal – Phase III EWAs	\$22,844	
Subtotal - Phase III – Sonoma Valley		\$57,544
TOTAL CONTRACT PREVIOUSLY APPROVED AND TASKS COMPLETED		\$99,993

Phase IV Both Dry Creek Valley and Sonoma Valley Additional Services

Task A1 Analysis of National Performance Management Data Set (NPMRDS) data	\$19,670	
Task A2 Update of LOS analysis and expansion of findings	\$15,509	
Task A3 Processing draft reports through County PRMD	\$10,761	
Task A4 Preparation for and attend 4 Public Meetings	\$14,000	
Subtotal - Phase IV- Dry Creek Valley and Sonoma Valley		\$59,940
TOTAL CONTRACT without OPTIONAL Task A5		\$159,933
OPTIONAL TASK A5 - For Both Dry Creek Valley and Sonoma Valley		
Task A5 – Expansion of analysis to incorporate current peak summer NPMRDS data from May 2018 to October 2018	\$ 7,255	
TOTAL CONTRACT with OPTIONAL Task A5		\$167,188

ASSIGNMENT, NOVATION AND CONSENT AGREEMENT

This ASSIGNMENT, NOVATION AND CONSENT AGREEMENT (the "Assignment") is made as of November 13, 2018, ("Assignment") by and among Omni Means Engineering Solutions, a California Corporation ("Assignor"), GHD, a California Corporation ("Assignee"), and the County of Sonoma, a political subdivision of the State of California ("County"). Assignor, Assignee, and County are sometimes referred to hereinafter individually as a "Party" and collectively as the "Parties."

RECITALS

WHEREAS, Assignor and County entered into that certain "Agreement for Consulting Services" (Agreement) dated August 18, 2017, for winery event traffic analysis; and

WHEREAS, Assignor and Assignee have entered into an agreement whereby Assignor has sold all of its business operations to Assignee, including Assignor's rights under the Agreements; and

WHEREAS, Assignor has accomplished that assignment through that certain "Assignment, Novation, and Consent Agreement" by and between the County, Assignor, and Assignee of even date herewith; and

WHEREAS, Assignee has consented to the assignment of all of Assignor's rights and obligations under the Agreement; and

WHEREAS, Article 11 of the Agreement dated August 18, 2017 requires the County's written consent to any such assignment; and

WHEREAS, the Parties desire to substitute Assignee in place of Assignor with respect to the Agreement.

AGREEMENT

NOW, THEREFORE, in consideration of the promises hereto and the mutual covenants and agreements herein set forth, the Parties agree as follows:

1. Incorporation of Recitals. The foregoing recitals are true and correct and are hereby incorporated into and form a material part of this Assignment.
2. Assignment. Assignor does hereby assign, transfer, and convey to the Assignee as of November 13, 2018 (the "Effective Date") all of Assignor's title, rights, obligations, and interest in, to, and under Agreements.
3. Assumption of Assignor's Obligations. Assignor and Assignee understand and agree that any transfers or assignments of the Agreement are conditioned upon the Assignee, as successor in interest, accepting all rights and/or obligations under the Agreement as of the Effective Date and further understand and agree

- that Assignor is not relieved of any of its obligations under the Agreement prior to the Effective Date. Assignee hereby accepts such assignment of the Agreement as of the Effective Date, and agrees to assume all of Assignor's duties and obligations in, to, and under the Agreement from and after the Effective Date.
4. Assignee's Representations. Assignee represents and warrants that it has the operational and financial ability, as well as the legal authority, to satisfy all of the obligations under the Agreement.
 5. County Consent to Substitution. County further consents to the substitution and novation of Assignee in place and instead of Assignor from and after the Effective Date.
 6. Novation. County and Assignee each consent to fully release Assignor from any and all obligations, responsibilities, and duties under the Agreement from and after the Effective Date.
 7. Cooperation. Assignor agrees that it shall cooperate with Assignee in effectuating an orderly transition of County information to Assignee in order for Assignee to fulfill its obligations, responsibilities, and duties under the Agreement from and after the Effective Date.
 8. Indemnification by Assignee. Assignee agrees to defend and indemnify Assignor from any and all claims, actions, judgments, liabilities, proceedings and costs, including reasonable attorneys' fees and other costs of defense and damages, resulting from and related to the Agreement and to assume Assignor's obligations under the Agreement to defend and indemnify County from and after the Effective Date.
 9. Indemnification by Assignor. Assignor agrees to defend and indemnify County and Assignee from any and all claims, actions, judgments, liabilities, proceedings and costs, including reasonable attorneys' fees, resulting from and related to Assignor's performance under the Agreement and subject to the terms of the Agreement prior to the Effective Date.
 10. Integration. This Assignment constitutes the entire agreement concerning the assignment between the Parties and it may not be modified, altered or amended other than in writing executed by the party sought to be charged thereby.
 11. Counterparts. This Assignment may be executed in faxed counterparts, and in such event, the counterpart signatures shall be assembled and shall together constitute a complete agreement.

IN WITNESS WHEREOF, THE PARTIES ACKNOWLEDGE THAT THEY HAVE READ THE ASSIGNMENT, NOVATION AND CONSENT, UNDERSTAND IT AND AGREE TO BE BOUND BY ITS TERMS. EACH PARTY HAS FULL POWER AND AUTHORITY TO ENTER INTO AND PERFORM THIS ASSIGNMENT, NOVATION AND CONSENT, AND THE PERSON SIGNING THIS ASSIGNMENT, NOVATION AND CONSENT ON BEHALF OF EACH HAS BEEN PROPERLY AUTHORIZED AND EMPOWERED TO ENTER INTO THIS ASSIGNMENT, NOVATION AND CONSENT.

ASSIGNOR: _____

By: _____

Name: _____

Title: _____

Date: _____

ASSIGNEE: _____

By: _____

Name: _____

Title: _____

Date: _____

COUNTY: COUNTY OF SONOMA

CERTIFICATES OF INSURANCE REVIEWED
AND ON FILE:

By: _____

Director, Permit and Resource Management

Date: _____

APPROVED AS TO FORM FOR COUNTY:

By: _____

County Counsel

Date: _____

AGREEMENT EXECUTED:

By: _____

Director, Permit and Resource Management

Date: _____

ASSIGNMENT, NOVATION AND CONSENT AGREEMENT

This ASSIGNMENT, NOVATION AND CONSENT AGREEMENT (the "Assignment") is made as of November 13, 2018, ("Assignment") by and among Omni Means Engineering Solutions, a California Corporation ("Assignor"), GHD, a California Corporation ("Assignee"), and the County of Sonoma, a political subdivision of the State of California ("County"). Assignor, Assignee, and County are sometimes referred to hereinafter individually as a "Party" and collectively as the "Parties."

RECITALS

WHEREAS, Assignor and County entered into a certain "Agreement for Consulting Services" (Agreement) dated April 7, 2015, for traffic study peer reviews; and

WHEREAS, County exercised one of its two options to extend the term of the Agreement by one year on January 3, 2018; and

WHEREAS, Assignor and Assignee have entered into an agreement whereby Assignor has sold all of its business operations to Assignee, including Assignor's rights under the Agreement; and

WHEREAS, Assignor has accomplished that assignment through that certain "Assignment, Novation, and Consent Agreement" by and between the County, Assignor, and Assignee of even date herewith; and

WHEREAS, Assignee has consented to the assignment of all of Assignor's rights and obligations under the Agreement; and

WHEREAS, Article 11 of the Agreement dated April 7, 2015 requires the County's written consent to any such assignment; and

WHEREAS, the Parties desire to substitute Assignee in place of Assignor with respect to the Agreement.

AGREEMENT

NOW, THEREFORE, in consideration of the promises hereto and the mutual covenants and agreement herein set forth, the Parties agree as follows:

1. Incorporation of Recitals. The foregoing recitals are true and correct and are hereby incorporated into and form a material part of this Assignment.
2. Assignment. Assignor does hereby assign, transfer, and convey to the Assignee as of November 13, 2018 (the "Effective Date") all of Assignor's title, rights, obligations, and interest in, to, and under Agreement.

3. Assumption of Assignor's Obligations. Assignor and Assignee understand and agree that any transfers or assignments of the Agreement are conditioned upon the Assignee, as successor in interest, accepting all rights and/or obligations under the Agreement as of the Effective Date and further understand and agree that Assignor is not relieved of any of its obligations under the Agreement prior to the Effective Date. Assignee hereby accepts such assignment of the Agreement as of the Effective Date, and agrees to assume all of Assignor's duties and obligations in, to, and under the Agreement from and after the Effective Date.
4. Assignee's Representations. Assignee represents and warrants that it has the operational and financial ability, as well as the legal authority, to satisfy all of the obligations under the Agreement.
5. County Consent to Substitution. County further consents to the substitution and novation of Assignee in place and instead of Assignor from and after the Effective Date.
6. Novation. County and Assignee each consent to fully release Assignor from any and all obligations, responsibilities, and duties under the Agreement from and after the Effective Date.
7. Cooperation. Assignor agrees that it shall cooperate with Assignee in effectuating an orderly transition of County information to Assignee in order for Assignee to fulfill its obligations, responsibilities, and duties under the Agreement from and after the Effective Date.
8. Indemnification by Assignee. Assignee agrees to defend and indemnify Assignor from any and all claims, actions, judgments, liabilities, proceedings and costs, including reasonable attorneys' fees and other costs of defense and damages, resulting from and related to the Agreement and to assume Assignor's obligations under the Agreement to defend and indemnify County from and after the Effective Date.
9. Indemnification by Assignor. Assignor agrees to defend and indemnify County and Assignee from any and all claims, actions, judgments, liabilities, proceedings and costs, including reasonable attorneys' fees, resulting from and related to Assignor's performance under the Agreement and subject to the terms of the Agreement prior to the Effective Date.
10. Integration. This Assignment constitutes the entire agreement concerning the assignment between the Parties and it may not be modified, altered or amended other than in writing executed by the party sought to be charged thereby.
11. Counterparts. This Assignment may be executed in faxed counterparts, and in such event, the counterpart signatures shall be assembled and shall together constitute a complete agreement.

IN WITNESS WHEREOF, THE PARTIES ACKNOWLEDGE THAT THEY HAVE READ THE ASSIGNMENT, NOVATION AND CONSENT, UNDERSTAND IT AND AGREE TO BE BOUND BY ITS TERMS. EACH PARTY HAS FULL POWER AND AUTHORITY TO ENTER INTO AND PERFORM THIS ASSIGNMENT, NOVATION AND CONSENT, AND THE PERSON SIGNING THIS ASSIGNMENT, NOVATION AND CONSENT ON BEHALF OF EACH HAS BEEN PROPERLY AUTHORIZED AND EMPOWERED TO ENTER INTO THIS ASSIGNMENT, NOVATION AND CONSENT.

ASSIGNOR: _____

By: _____

Name: _____

Title: _____

Date: _____

ASSIGNEE: _____

By: _____

Name: _____

Title: _____

Date: _____

COUNTY: COUNTY OF SONOMA

CERTIFICATES OF INSURANCE REVIEWED
AND ON FILE:

By: _____

Director, Permit and Resource Management

Date: _____

APPROVED AS TO FORM FOR COUNTY:

By: _____

County Counsel

Date: _____

AGREEMENT EXECUTED:

By: _____

Director, Permit and Resource Management

Date: _____



County of Sonoma Agenda Item Summary Report

Clerk of the Board
575 Administration Drive
Santa Rosa, CA 95403

Agenda Item Number: 33
(This Section for use by Clerk of the Board Only.)

To: Board of Supervisors

Board Agenda Date: November 13, 2018

Vote Requirement: Majority

Department or Agency Name(s): Transportation and Public Works

Staff Name and Phone Number:

Johannes J. Hoevertsz 707-565-2231

Supervisorial District(s):

Fourth

Title: Charles M. Schulz – Sonoma County Airport Advertising Policy Resolution

Recommended Actions:

Adopt a resolution amending the Advertising Policy for the Charles M. Schulz – Sonoma County Airport.

Executive Summary:

The Charles M. Schulz – Sonoma County Airport (Airport) is requesting that the Board of Supervisors adopt a Resolution amending the 2010 Airport Advertising Policy in order to reflect current Airport infrastructure, evolving tenant needs, and advanced advertising delivery methods.

Discussion:

Advertising is an important element of Airport concessions, as well as an essential tool for Airport leaseholders to promote their business. In order to maximize the effectiveness of on premise advertising for commercial tenants, third party advertisers, and airport passengers, the Airport has developed an Airport Advertising Policy. The Policy is intended allow businesses to promote their products and services in ways are non-offensive, aesthetically pleasing, and do not interfere with Airport operations or safety.

On November 9th, 2010, the Sonoma County Board of Supervisors approved Resolution 10-0810 adopting an Advertising Policy for the Charles M. Schulz – Sonoma County Airport. In the eight years since that policy was approved, there has been considerable growth in Airport operations, an increase in the number and diversity of Airport tenants, and changes to ways in which advertising messages are delivered to consumers. Additionally, the Airport is continuing to expand commercial air service and is in the first phase of a significant terminal expansion project. In order to address current advertising realities as well as accommodate future expansion, Airport staff in conjunction with County Counsel have made the following updates and improvements to the 2010 Airport Advertising Policy:

- The adoption of seven (7) advertising restriction sub-categories including General Restrictions, Location Restrictions, Content Restrictions, Terminal Building Restrictions, Other Airport Buildings and Structures Restrictions, Temporary Advertising Sign Restrictions, and Indemnity.

- Clarification of compliance with federal and state laws where applicable, such as referencing laws that govern state controlled substances (including cannabis) or the promotion of unlawful goods or services.

Under the existing Airport Advertising Policy, any amendments require approval by the Airport Manager or his designee in writing, before installation or display of any advertisement. In addition, Airport staff will continue to periodically review advertising displays and signage on Airport premises to ensure compliance with this Policy.

The Department of Transportation and Public Works recommends that the Board of Supervisors approve the revised version of the Airport Advertising Policy and adopt a resolution adopting the new Policy.

Prior Board Actions:

November 9, 2010 - Resolution No. 10-0810

Strategic Plan Alignment Goal 1: Safe, Healthy, and Caring Community

An updated Airport Advertising Policy allows businesses to promote their products and services in ways that are non-offensive, aesthetically pleasing, and do not interfere with Airport operations or safety.

Fiscal Summary

Expenditures	FY 18-19 Adopted	FY 19-20 Projected	FY 20-21 Projected
Budgeted Expenses			
Additional Appropriation Requested			
Total Expenditures			

Funding Sources

General Fund/WA GF			
State/Federal			
Fees/Other			
Use of Fund Balance			
Contingencies			
Total Sources			

Narrative Explanation of Fiscal Impacts:

None

Staffing Impacts			
Position Title (Payroll Classification)	Monthly Salary Range (A – I Step)	Additions (Number)	Deletions (Number)
Narrative Explanation of Staffing Impacts (If Required):			
None			
Attachments:			
Advertising Policy; Resolution; Advertising Policy Redline			
Related Items “On File” with the Clerk of the Board:			
Resolution No. 10-0810 November 9 th , 2010			

**Charles M. Schulz –
Sonoma County Airport**

Advertising Policy

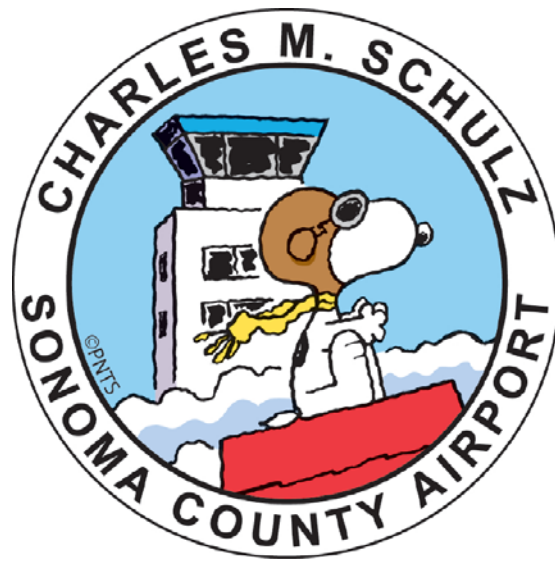

DRAFT September 17, 2018

**Charles M. Schulz – Sonoma County Airport
Advertising Policy
DRAFT**

This policy provides advertising and signage criteria for the Charles M. Schulz – Sonoma County Airport (“Airport”). This policy does not apply to activities of the Airport and its Airport Manager, or designee, to identify, inform the public, or promote Airport facilities, services, or tenants, or otherwise market the Airport.

Advertising is recognized as an essential part of airport concessions, information and identity programs, but must be aesthetically consistent with the Airport’s design and architecture and not interfere with operational efficiencies and safety. A balance between Airport advertising and other informational systems must be maintained in order to preserve visual continuity and avoid clutter and message overload. Advertising for the purpose of this policy is defined as the display of paid announcements in any form to promote businesses other than the Airport or the business of Airport tenants on their respective leaseholds.

All signs and other types of advertising on Airport property must be consistent with these guidelines and approved by the Airport Manager, or designee, in writing, before installation. Existing signs that do not meet the guidelines in this policy must be removed; however, if a sign has previously been approved by Airport, that sign shall be allowed to remain as is until changed, replaced, or relocated, at which time the sign must be changed to conform to this policy.

Airport Management will, periodically, review the Terminal area and leaseholds for compliance with this policy.

1. General Restrictions

Signs and other advertisements on Airport property must meet the following general restrictions:

1.1 Advertisements in public areas are the responsibility of the Airport. Advertisements in leased areas are the responsibility of the tenant but those advertisements must comply with this policy.

1.2 Advertisements may not use exposed cans, raceways, crossovers, or exposed neon tubing.

1.3 All advertisements must comply with any applicable safety standards.

1.4 Advertisements shall not advertise services in direct competition with the Airport’s business objectives.

1.5 Advertisements may not contain flashing messages or be illuminated by strobe or laser lighting.

1.6 The Airport will not provide telephone support (e.g., answer questions about products, services, companies, etc.), telephone endorsements (e.g., provide a positive review of a product or service or recommend any product or service) or take orders for products or services advertised at the Airport.

2. Location Restrictions

Adopted _____

2.1 No advertisements may be placed on exterior doors or windows except those required to meet safety standards.

2.2 No advertisements may be placed on the roof of any building or on any structure atop a building.

2.3 Except as noted above, no advertising of any nature is allowed along roadways, walkways, pathways, landscaped areas, or other grounds of the Airport.

3. Content Restrictions

3.1 Advertisements shall promote or solicit the sale, rental, distribution or availability of goods, services, food, entertainment, events, programs, transactions, products or property, or more generally promote an entity that engages in such activities.

3.2 Advertisements shall not contain commentary, advocacy, or promotion of or on social, political, or religious issues.

3.3 Advertisements shall not be false, misleading, or deceptive.

3.4 Advertisements shall not contain obscene, pornographic, sexually oriented material, images of nudity or salacious content.

3.5 Advertisements shall not contain depictions of graphic violence, blood, gore, or other violent imagery, symbolism or words including images of firearms or weapons.

3.6 Advertisements shall not promote hatred, bigotry, violence or intolerance.

3.7 Advertisements shall not contain or imply profane or vulgar language or material.

3.8 Advertisements shall not include adult oriented products, adult entertainment businesses or services, adult book stores, adult video stores, nude or partially nude dance clubs, adult telephone services, adult internet sites, any type of escort service or similar service.

3.9 Advertisements shall not include contraceptives, medications or treatments to enhance sexual function and performance.

3.10 Advertisements shall not include tobacco products, electronic cigarettes, hard liquors, cannabis products, cannabis businesses or cannabis services or any illegal/prohibited substances per federal and/or state law.

3.11 Advertisements shall not promote unlawful or illegal goods, services or activities per federal and/or state law.

4. Terminal Building

Within the Airport's terminal building, all advertising in public common use spaces that are designated for use by the Airport's in-terminal advertising program shall be carried out through the advertising program manager. Advertising in public and common use spaces that are not designated for use by the Airport's in-terminal advertising program shall be allowed entirely at the discretion of and subject to the judgment of the Airport Manager or designee, subject to the general rules set forth above. Advertising in spaces exclusively or preferentially leased by tenants shall be restricted to only goods and services offered by the tenant.

Adopted _____

All advertisements proposed in the terminal building, no matter where or how placed, are subject to the written consent and approval of the Airport Manager, or designee, prior to installation.

The Airport Manager, or designee, shall have the right to remove and dispose of any sign, brochure, flyer, advertisement, circular, picture, sketch, drawing or other commercial message that violates any of these policies. The Airport Manager, or designee, shall have the right to post or cause to be posted signs, brochures, flyers, advertisements, circulars, pictures, sketches, drawings or other commercial messages that promote the use of Airport-provided services.

5. Other Airport Buildings and Structures

Advertising is not permitted on the exterior of or on the grounds of any other building or structure on Airport property without prior approval of the Airport Manager. This policy does not apply to activities of tenant/leaseholders to identify, inform the public, or promote its services or business, or otherwise market their business. Any promotion or identification of a business or tenant of the Airport must comply with any applicable signage ordinance that is in effect or enacted by the County.

6. Temporary Advertising Signs

Temporary signs that may be considered advertising in nature may be used by the Airport tenant contractors during construction periods to identify projects, work sites, contractors and work in process as specified in Airport-approved contract documents.

7. Indemnity

Advertisers and their agencies will indemnify and hold harmless the County of Sonoma and the Sonoma County Airport, its officers and agents, against all expenses and losses resulting from the publication of the contents of the advertisement, including claims for libel, violation of privacy, copyright infringement, or plagiarism.

Neither the Sonoma County Airport's name, logo, and designations, nor testimonials by current Airport employees, may be used in advertisements to endorse non-Airport products or services, unless the Airport Manager, or designee, has specifically contracted with a particular advertiser to promote or endorse a product or service apart from the purposes of the advertising program.



County of Sonoma
State of California

Date: November 13, 2018

Item Number: _____
Resolution Number: _____

4/5 Vote Required

**Resolution Of The Board Of Supervisors Of The County Of Sonoma, State Of California,
Adopting an Amended Advertising Policy for the Charles M. Schulz – Sonoma County Airport.**

Whereas, on November 9, 2010, by Resolution No. 10-0810, the Board adopted an advertising policy for the Charles M. Schulz – Sonoma County Airport (“Airport”); and

Whereas, during its regular meeting on November 13, 2018, Airport staff presented to the Board an amended advertising policy for the Airport; and

Whereas, this Resolution is consistent with Ordinance No. 5901, adopted by the Board on September 14, 2010, and California Government Code Section 26109, authorizing the sale of advertising space on County property; and

Whereas, the Board has duly considered the amended Airport advertising policy.

Now, Therefore, Be It Resolved that the Board of Supervisors hereby adopts the amended Airport advertising policy presented to the Board on November 13, 2018, and attached to this Resolution.

Supervisors:

Gorin:

Rabbitt:

Zane:

Hopkins:

Gore:

Ayes:

Noes:

Absent:

Abstain:

So Ordered.

**Charles M. Schulz –
Sonoma County Airport**

Advertising Policy

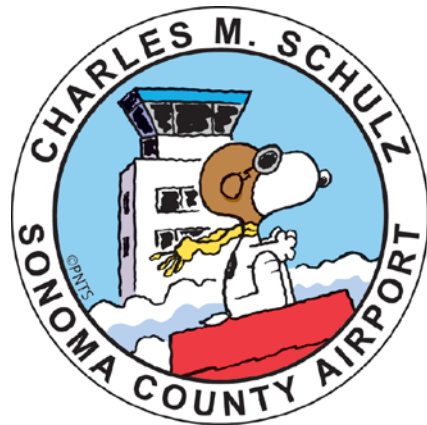

**Adopted by the
Sonoma County Board of Supervisors
November 9, 2010
DRAFT September 17, 2018**

**Charles M. Schulz – Sonoma County Airport
Advertising Policy**

~~Approved by the County of Sonoma Board of Supervisors on
November 9, 2010
DRAFT~~

This policy provides advertising and signage criteria for the Charles M. Schulz – Sonoma County Airport (“Airport”). This policy does not apply to activities of the Airport and its Airport Manager, or designee, to identify, inform the public, or promote Airport facilities, services, or tenants, or otherwise market the Airport.

Advertising is recognized as an essential part of airport concessions, information and identity programs, but must be aesthetically consistent with the Airport’s design and architecture and not interfere with operational efficiencies and safety. A balance between Airport advertising and other informational systems must be maintained in order to preserve visual continuity and avoid clutter and message overload. Advertising for the purpose of this policy is defined as the display of paid announcements in any form to promote businesses other than the Airport or the business of Airport tenants on their respective leaseholds.

All signs and other types of advertising on Airport property must be consistent with these guidelines and approved by the Airport Manager, or designee, in writing, before installation. Existing signs that do not meet the guidelines in this policy must be removed; however, if a sign has previously been approved by Airport, that sign shall be allowed to remain as is until changed, replaced, or relocated, at which time the sign must be changed to conform to this policy.

Airport Management will, periodically, review the Terminal area and leaseholds for compliance with this policy.

1. ~~General~~ RulesRestrictions

Signs and other advertisements on Airport property must meet the following general ~~rulesrestrictions~~:

1.1 Advertisements in public areas are the responsibility of the Airport. Advertisements in leased areas are the responsibility of the tenant but those advertisements must comply with this policy.

~~**1.2** No advertisements may be placed on exterior doors or windows except those required to meet safety standards.~~

Charles M. Schulz – Sonoma County Airport
Advertising Policy

Adopted 11/9/2010

~~1.3 1.2~~ No advertisements may be placed on the roof of any building or on any structure atop a building.

Formatted: Indent: First line: 0.5"

~~1.4~~ Advertisements may not use exposed cans, raceways, crossovers, or exposed neon tubing.

~~1.53~~ All advertisements must ~~meet~~ comply with any applicable safety standards.

~~1.6~~ Advertisements shall not contain obscene, pornographic or violent material; market tobacco products, hard liquors, or illegal/prohibited substances; contain commentary, advocacy, or promotion of or on social, political, religious, or rhetorical issues; advocate for or against political candidates, political campaigns, ballot measures, or political parties or organizations; or advocate a position (directly or indirectly) on any public policy or social issue.

~~1.7 1.4~~ Advertisements shall not advertise services in direct competition with the Airport's business objectives.

~~1.8~~ Advertisements shall not be false, misleading, or deceptive.

~~1.9~~ Advertisements shall not contain objectionable or controversial material such that the advertisement would be contrary to community standards or would detract from the mission of the Airport to provide a comfortable, pleasant passenger experience.

~~1.10~~ Except as noted above, no advertising of any nature is allowed along roadways, walkways, pathways, landscaped areas, or other grounds of the Airport.

~~1.11~~

~~1.5~~ Advertisements may not contain flashing messages or be illuminated by strobe or laser lighting.

~~1.12~~ Advertising on the exterior of the terminal building or any permanent structure on the Airport property is prohibited. In addition, advertisements on the exterior of passenger holding building, bridges, fences, or aircraft ground service equipment are prohibited, except for advertising posted by the Airport.

~~1.13 1.6~~ The Airport will not provide telephone support (e.g., answer questions about products, services, companies, etc.), telephone endorsements (e.g., provide a positive review of a product or service or recommend any product or service) or take orders for products or services advertised at the Airport.

Formatted: Indent: First line: 0.5"

2. Location Restrictions

Charles M. Schulz – Sonoma County Airport
Advertising Policy

Adopted 11/9/2010

2.1 No advertisements may be placed on exterior doors or windows except those required to meet safety standards.

2.2 No advertisements may be placed on the roof of any building or on any structure atop a building.

Formatted: Indent: First line: 0.5"

~~1.14 Advertisements for gaming activities shall be required to be approved by the Airport Manager prior to execution of a contract for those ads. When the request for this type of ad is received and the Airport Manager agrees in concept to the ad, the Airport Manager shall direct a memorandum to the Board of Supervisors informing the Board of the request. If no Board member has objections, the contract can be executed. If any Board member should have objections with the proposed ad then the ad shall be reworked at no cost to the Airport and resubmitted for approval. Finally, should these types of ads be approved, a pamphlet for gaming addiction shall be placed in the brochure racks in the terminal.~~

~~2.~~ 2.3 Except as noted above, no advertising of any nature is allowed along roadways, walkways, pathways, landscaped areas, or other grounds of the Airport.

3. Content Restrictions

3.1 Advertisements shall promote or solicit the sale, rental, distribution or availability of goods, services, food, entertainment, events, programs, transactions, products or property, or more generally promote an entity that engages in such activities.

3.2 Advertisements shall not contain commentary, advocacy, or promotion of or on social, political, or religious issues.

3.3 Advertisements shall not be false, misleading, or deceptive.

3.4 Advertisements shall not contain obscene, pornographic, sexually oriented material, images of nudity or salacious content.

3.5 Advertisements shall not contain depictions of graphic violence, blood, gore, or other violent imagery, symbolism or words including images of firearms or weapons.

3.6 Advertisements shall not promote hatred, bigotry, violence or intolerance.

3.7 Advertisements shall not contain or imply profane or vulgar language or material.

3.8 Advertisements shall not include adult oriented products, adult entertainment businesses or services, adult book stores, adult video stores, nude or partially nude dance clubs, adult telephone services, adult internet sites, any type of escort service or similar service.

Adopted ~~11/9/2010~~ _____

3.9 Advertisements shall not include contraceptives, medications or treatments to enhance sexual function and performance.

3.10 Advertisements shall not include tobacco products, electronic cigarettes, hard liquors, cannabis products, cannabis businesses or cannabis services or any illegal/prohibited substances per federal and/or state law.

3.11 Advertisements shall not promote unlawful or illegal goods, services or activities per federal and/or state law.

4. Terminal Building

Within the Airport's terminal building, all advertising in public common use spaces that are designated for use by the Airport's in-terminal advertising ~~concessionaire program~~ shall be carried out through the advertising program ~~managed by that concessionaire manager~~. Advertising in public and common use spaces that are not designated for use by the Airport's in-terminal advertising ~~concessionaire program~~ shall be allowed entirely at the discretion of and subject to the judgment of the Airport Manager or designee, subject to the general rules set forth above. Advertising in spaces exclusively or preferentially leased by tenants shall be restricted to only goods and services offered by the tenant.

All advertisements proposed in the terminal building, no matter where or how placed, are subject to the written consent and approval of the Airport Manager, or designee, prior to installation.

The Airport Manager, or designee, shall have the right to remove and dispose of any sign, brochure, flyer, advertisement, circular, picture, sketch, drawing or other commercial message that violates any of these policies. The Airport Manager, or designee, shall have the right to post or cause to be posted signs, brochures, flyers, advertisements, circulars, pictures, sketches, drawings or other commercial messages that promote the use of Airport-provided services.

3. — 5. Other Airport Buildings and Structures

Advertising is not permitted on the exterior of or on the grounds of any other building or structure on Airport property- without prior approval of the Airport Manager. This policy does not apply to activities of tenant/leaseholders to identify, inform the public, or promote its services or business, or otherwise market their business. Any promotion or identification of a business or tenant of the Airport must comply with any applicable signage ordinance that is in effect or enacted by the County.

4. — 6. Temporary Advertising Signs

Temporary signs that may be considered advertising in nature may be used by the Airport tenant contractors during construction periods to identify projects, work sites, contractors and work in process as specified in Airport-approved contract documents.

*Charles M. Schulz – Sonoma County Airport
Advertising Policy*

Adopted ~~11/9/2010~~ _____

5. — 7. Indemnity

Advertisers and their agencies will indemnify and hold harmless the County of Sonoma and the Sonoma County Airport, its officers and agents, against all expenses and losses resulting from the publication of the contents of the advertisement, including claims for libel, violation of privacy, copyright infringement, or plagiarism.

Neither the Sonoma County Airport's name, logo, and designations, nor testimonials by current Airport employees, may be used in advertisements to endorse non-Airport products or services, unless the Airport Manager, or designee, has specifically contracted with a particular advertiser to promote or endorse a product or service apart from the purposes of the advertising program.



County of Sonoma Agenda Item Summary Report

Clerk of the Board
575 Administration Drive
Santa Rosa, CA 95403

Agenda Item Number: 34
(This Section for use by Clerk of the Board Only.)

To: Board of Supervisors

Board Agenda Date: November 13, 2018

Vote Requirement: Majority

Department or Agency Name(s): Transportation and Public Works

Staff Name and Phone Number:

Johannes J. Hoevertsz, 707-565-2231

Supervisorial District(s):

Fourth

Title: Agreement for Environmental Assessment for Perimeter Fence Upgrade at Charles M. Schulz – Sonoma County Airport

Recommended Actions:

Authorize the Chair to execute an agreement with RS&H California, Inc., for preparation of a National Environmental Policy Act (NEPA) and California Environmental Quality Act (CEQA) environmental review in order to upgrade of the Sonoma County Airport wildlife perimeter fence. The proposed value of the agreement is \$155,607, with a three-year term ending November 13, 2021.

Executive Summary:

The Department of Transportation and Public Works (TPW) is requesting the Board of Supervisors authorize and execute an agreement with RS&H California Inc. If approved, RS&H California Inc. will be responsible for providing Planning and Environmental Services to the Sonoma County Airport including preparation of both a National Environmental Policy Act (NEPA) and a California Environmental Quality Act (CEQA) environmental review for an upgraded perimeter fence at the Charles M. Schulz – Sonoma County Airport.

Discussion:

The risks of wildlife incursion on to the Airfield creates a substantial hazard to both commercial and general aviation traffic. In order to meet the requirements of a recently completed Wildlife Hazard Assessment and Part 139 Safety Inspections and Certifications, the Federal Aviation Administration (FAA) has allocated grant funding to upgrade the Sonoma County Airport perimeter fence. If approved, the agreement with RS&H California, Inc. will require the consultant to engage with the FAA and other stakeholder agencies to provide environmental review services for upgrading the current 8-foot high chain link fence. Once completed, the new fence and associated wildlife barriers will meet requirements set forth in FAA Advisory Circular 150/5370-10G, Items F-162 (Chain Link Fence), F-163 (Wildlife Deterrent Fence Skirt), F-164 (Wildlife Exclusion Fence), and FAA Certalert 16-03. Because portions of the Airport fence are located in close proximity to riparian corridors and habitat identified for protection of threatened and endangered species, additional consideration will be given to

environmental impacts associated with the fence installation. These potential impacts will necessitate increased examination of fence placement, construction methods, and possible mitigation options.

In August 2017, the Airport released a Request for Qualifications (RFQ) to solicit interested and qualified environmental consultants with a strong background in the preparation of CEQA and NEPA documents to conduct reviews for the Airport proposed improvements and related policy changes. The goal of the RFQ was to meet the requirements of the National Environmental Policy Act (NEPA) and the California Environmental Quality Act (CEQA) for:

1. The installation and upgrading of Airport perimeter fencing
2. Relocation of the Aircraft Rescue and Firefighting (ARFF) facility.

After reviewing preliminary locations for the proposed Aircraft and Rescue Fire Fighting (ARFF) relocation, it was determined that the ARFF relocation should be postponed pending further studies and that the fencing environmental reviews would take priority at this time.

The sole responder to the RFQ was RS&H California, Inc., a leading full-service aviation-consulting firm offering unique and applicable expertise in CEQA and NEPA compliance, airport planning, and airport design. TPW desires to enter into an agreement with RS&H California, Inc. for a term of three (3) years for consulting services and plan designs

The agreement includes consulting services to prepare two concise environmental reviews to meet the requirements of the NEPA and the CEQA. These environmental reviews are required to proceed with the construction of the Airport wildlife perimeter fence as part of security improvements required by a recently completed Wildlife Hazard Assessment and Part 139 Safety Inspections and Certifications.

The major tasks involved for the successful completion to the CEQA and NEPA process are as follows:

- Task 1: Develop Project Objectives/Purpose and Need Statement - These will succinctly describe the objectives achieved by the proposed project in terms that are understandable to individuals who are not familiar with aviation activities.
- Task 2: Develop Project Description - This will contain a detailed description of the proposed project, including graphics that depict the proposed project.
- Task 3: Identification and Evaluation of Alternatives - This will include the development of screening criteria for evaluating potential alternatives.
- Task 4: Prepare Existing Conditions/Affected Environment Section - This document will detail existing conditions around the Airport as they relate to the proposed project.
- Task 5: Develop Agency Coordination and Consultation Strategy - This task includes the development of strategy for coordination and consultation with regulatory agencies, including working with the Federal Aviation Administration (FAA) to conduct meetings early in the process to educate the regulatory agencies and to establish a schedule for coordination and consultation throughout the process.
- Task 6: Prepare Environmental Impact Analyses - This task will analyze the potential impact categories identified in the CEQA Guidelines Appendix G as well as the environmental resource categories identified in FAA Order 1050.1F.

Task 7: Prepare Preliminary Draft NEPA Documentation – Includes preparation of a preliminary draft NEPA document for review by Sonoma County and the FAA, containing all analyses and appendices needed.

Task 8: Prepare Administrative Draft CEQA Documentation – This task includes preparation of an administrative draft CEQA document for review by Sonoma County, including all analyses and appendices needed.

Tasks 9 & 10: Prepare and Publish Draft NEPA/CEQA Documentation – These tasks consist of revising the preliminary draft NEPA/CEQA documents in accordance with comments provided by Sonoma County and the FAA and provide an annotated list of comments to assist Sonoma County in understanding how the draft document changed. In Addition, a Notice of Availability for Publication in a local newspaper indicating the publishing of the draft NEPA/CEQA documents.

Tasks 11 and 12: Prepare Preliminary Final NEPA.CEQA Documentation – Following a 30-day public comment period on the posted draft NEPA/CEQA document, these tasks will consist of collecting, reviewing, summarizing and responding to all agency and public comments. A response to comments will be created for review and comment by Sonoma County and the FAA. Revised NEPA/CEQA draft documents, with implemented changes resulting from responses to comments will be submitted to Sonoma County for review and comment.

Tasks 13 & 14: Prepare and Publish Final NEPA/CEQA Documentation – An annotated list of comments will be provided to assist Sonoma County and the FAA in understanding how the documents changed from the preliminary drafts. A Notice of Availability will be published in a local newspaper indicating final NEPA/CEQA documents have been published.

Task 15: Public Outreach – This task will consist of planned activities including public workshops, social media strategies, and the development of collateral materials for meetings, workshops and website content to assist with public outreach.

Task 16: Project Management – This task will be ongoing throughout the entire contract and will include coordinating meetings, conference calls, preparing agendas, meeting minutes, sharing information before and after meetings, in order to facilitate the exchange of information and for Sonoma County staff to be fully apprised of the progress being made.

TPW recommends the Board of Supervisors authorize and execute the agreement with RS&H California Inc., the sole qualified responder in the amount \$155,607.00, for consulting on Airport improvements and compliance with CEQA and NEPA requirements.

Prior Board Actions:

None

Strategic Plan Alignment Goal 2: Economic and Environmental Stewardship

The preparation of Perimeter Fencing environmental reports at the Charles M. Schulz - Sonoma County Airport will enable the County to meet the requirements of the NEPA and CEQA.

Fiscal Summary			
Expenditures	FY 18-19 Adopted	FY 19-20 Projected	FY 20-21 Projected
Budgeted Expenses	\$50,000	\$85,000	\$20,000
Additional Appropriation Requested			
Total Expenditures	\$50,000	\$85,000	\$20,000
Funding Sources			
General Fund/WA GF			
State/Federal	\$45,330	\$77,060	\$18,130
Fees/Other	\$4,670	\$7,940	\$1,870
Use of Fund Balance			
Contingencies			
Total Sources	\$50,000	\$85,000	\$20,000
Narrative Explanation of Fiscal Impacts:			
<p>The proposed work will be funded by a Federal Aviation Grant Airport Improvement Program (AIP) grant. AIP grants provide funding for 90.66% of project costs with the remaining 9.34% funded through Airport operating income. The adopted Airport Fiscal Year 2018-19 budget includes funding for the local match portion of this agreement.</p>			
Staffing Impacts			
Position Title (Payroll Classification)	Monthly Salary Range (A – I Step)	Additions (Number)	Deletions (Number)
Narrative Explanation of Staffing Impacts (If Required):			
None			
Attachments:			
Agreement for Professional Services			
Related Items "On File" with the Clerk of the Board:			

AGREEMENT FOR PROFESSIONAL SERVICES

This agreement ("Agreement"), dated as of November 13, 2018 ("Effective Date") is by and between the County of Sonoma, a political subdivision of the State of California (hereinafter "County"), and RS&H California Inc. (hereinafter "Consultant").

RECITALS

WHEREAS, Consultant represents that it is a duly qualified Environmental Assessment Expert, experienced in conducting National Environmental Policy Act (NEPA) and California Environmental Quality Act (CEQA) environmental reviews and related services; and

WHEREAS, in the judgment of the County, it is necessary and desirable to employ the services of Consultant for the environmental review of the Airport's Perimeter Fence Upgrade.

NOW, THEREFORE, in consideration of the foregoing recitals and the mutual covenants contained herein, the parties hereto agree as follows:

AGREEMENT

1. Scope of Services.

1.1 Consultant's Specified Services. Consultant shall perform the services described in Exhibits "B1" and "B2," attached hereto and incorporated herein by this reference (hereinafter "Scope of Work"), and within the times and by the dates provided for in the Schedule set forth on Exhibit "C," attached hereto and incorporated herein by this reference, and otherwise pursuant to Article 7, Prosecution of Work. Consultant shall comply with the General Conditions set forth on Exhibit "A" attached hereto and incorporated herein by this reference. In the event of a conflict between the body of this Agreement and the exhibits, the provisions in the body of this Agreement shall control.

1.2 Cooperation With County. Consultant shall cooperate with County and County staff in the performance of all work hereunder.

1.3 Performance Standard. Consultant shall perform all work hereunder in a manner consistent with the level of competency and standard of care normally observed by a person practicing in Consultant's profession. County has relied upon the professional ability and training of Consultant as a material inducement to enter into this Agreement. Consultant hereby agrees to provide all services under this Agreement in accordance with generally accepted professional practices and standards of care, as well as the requirements of applicable federal, state and local laws, it being understood that acceptance of Contractor's work by County shall not operate as a waiver or release. If County determines that any of Consultant's work is not in accordance with such level of competency and standard of care, County, in its sole discretion, shall have the right to do any or all of the following: (a) require Consultant to meet with County to review the quality of the work and resolve matters of concern; (b) require Consultant to repeat the work at no additional charge until it is satisfactory; (c) terminate this Agreement pursuant to the provisions of Article 4; or (d) pursue any and all other remedies at law or in equity.

1.4 Assigned Personnel.

- a. Consultant shall assign only competent personnel to perform work hereunder. In the event that at any time County, in its sole discretion, desires the removal of any person

or persons assigned by Consultant to perform work hereunder, Consultant shall remove such person or persons immediately upon receiving written notice from County.

- b. Any and all persons identified in this Agreement or any exhibit hereto as the project manager, project team, or other professional performing work hereunder are deemed by County to be key personnel whose services were a material inducement to County to enter into this Agreement, and without whose services County would not have entered into this Agreement. Consultant shall not remove, replace, substitute, or otherwise change any key personnel without the prior written consent of County.
- c. In the event that any of Consultant's personnel assigned to perform services under this Agreement become unavailable due to resignation, sickness or other factors outside of Consultant's control, Consultant shall be responsible for timely provision of adequately qualified replacements.

2. Payment. Consultant shall be paid a lump sum amount of \$155,607.00 (ONE HUNDRED FIFTY-FIVE THOUSAND SIX HUNDRED AND SEVEN DOLLARS), regardless of the number of hours or length of time necessary for Consultant to complete the services. Consultant shall not be entitled to any additional payment for any expenses incurred in completion of the services.

A breakdown of costs used to derive the lump sum amount, including but not limited to hourly rates, estimated travel expenses and other applicable rates, is specified in the Budget (Exhibit "D"), attached hereto and incorporated herein by this reference.

Upon completion of the work, Consultant shall submit its bill[s] for payment in a form approved by County's Auditor and the Head of the County Department receiving the services. The bill[s] shall identify the services completed and the amount charged.

Unless otherwise noted in this Agreement, payments shall be made within the normal course of County business after presentation of an invoice in a form approved by the County for services performed. Payments shall be made only upon the satisfactory completion of the services as determined by the County.

Pursuant to California Revenue and Taxation code (R&TC) Section 18662, the County shall withhold seven percent of the income paid to Consultant for services performed within the State of California under this agreement, for payment and reporting to the California Franchise Tax Board, if Consultant does not qualify as: (1) a corporation with its principal place of business in California, (2) an LLC or Partnership with a permanent place of business in California, (3) a corporation/LLC or Partnership qualified to do business in California by the Secretary of State, or (4) an individual with a permanent residence in the State of California.

If Consultant does not qualify, County requires that a completed and signed Form 587 be provided by the Consultant in order for payments to be made. If Consultant is qualified, then the County requires a completed Form 590. Forms 587 and 590 remain valid for the duration of the Agreement provided there is no material change in facts. By signing either form, the Consultant agrees to promptly notify the County of any changes in the facts. Forms should be sent to the County pursuant to Article 12. To reduce the amount withheld, Consultant has the option to provide County with either a full or partial waiver from the State of California.

3. Term of Agreement. The term of this Agreement shall not exceed three (3) years from date of execution, unless terminated earlier in accordance with the provisions of Article 4 below.

4. Termination.

4.1 Termination Without Cause. Notwithstanding any other provision of this Agreement, at any time and without cause, County shall have the right, in its sole discretion, to terminate this Agreement by giving 5 days written notice to Consultant.

4.2 Termination for Cause. Notwithstanding any other provision of this Agreement, should Consultant fail to perform any of its obligations hereunder, within the time and in the manner herein provided, or otherwise violate any of the terms of this Agreement, County may immediately terminate this Agreement by giving Consultant written notice of such termination, stating the reason for termination.

4.3 Delivery of Work Product and Final Payment upon Termination.

In the event of termination, Consultant, within 14 days following the date of termination, shall deliver to County all reports, original drawings, graphics, plans, studies, and other data or documents, in whatever form or format, assembled or prepared by Consultant or Consultant's subcontractors, consultants, and other agents in connection with this Agreement and shall submit to County an invoice showing the services performed, hours worked, and copies of receipts for reimbursable expenses up to the date of termination.

4.4 Payment upon Termination. Upon termination of this Agreement by County, Consultant shall be entitled to receive as full payment for all services satisfactorily rendered and reimbursable expenses properly incurred hereunder, an amount which bears the same ratio to the total payment specified in the Agreement as the services satisfactorily rendered hereunder by Consultant bear to the total services otherwise required to be performed for such total payment; provided, however, that if services which have been satisfactorily rendered are to be paid on a per-hour or per-day basis, Consultant shall be entitled to receive as full payment an amount equal to the number of hours or days actually worked prior to the termination times the applicable hourly or daily rate; and further provided, however, that if County terminates the Agreement for cause pursuant to Section 4.2, County shall deduct from such amount the amount of damage, if any, sustained by County by virtue of the breach of the Agreement by Consultant.

4.5 Authority to Terminate. The Board of Supervisors has the authority to terminate this Agreement on behalf of the County. In addition, the Purchasing Agent or Transportation and Public Works Department Head, in consultation with County Counsel, shall have the authority to terminate this Agreement on behalf of the County.

5. Indemnification. Consultant agrees to accept all responsibility for loss or damage to any person or entity, including County, and to indemnify, hold harmless, and release County, its officers, agents, and employees, from and against any actions, claims, damages, liabilities, disabilities, or expenses, that may be asserted by any person or entity, including Consultant, that arise out of, pertain to, or relate to Consultant's or its agents', employees', contractors', subcontractors', or invitees' performance or obligations under this Agreement. Consultant agrees to provide a complete defense for any claim or action brought against County based upon a claim relating to such Consultant's or its agents', employees', contractors', subcontractors', or invitees' performance or obligations under this Agreement. Consultant's obligations under this Section apply whether or not there is concurrent or contributory negligence on County's part, but to the extent required by law, excluding liability due to County's conduct. County shall have the right to select its legal counsel at Consultant's expense, subject to Consultant's approval, which shall not be unreasonably withheld. This indemnification obligation is not limited in any way by any

limitation on the amount or type of damages or compensation payable to or for Consultant or its agents under workers' compensation acts, disability benefits acts, or other employee benefit acts.

6. Insurance. With respect to performance of work under this Agreement, Consultant shall maintain and shall require all of its subcontractors, consultants, and other agents to maintain, insurance as described in Exhibit "E," which is attached hereto and incorporated herein by this reference.

7. Prosecution of Work. The execution of this Agreement shall constitute Consultant's authority to proceed immediately with the performance of this Agreement. Performance of the services hereunder shall be completed within the time required herein, provided, however, that if the performance is delayed by earthquake, flood, high water, or other Act of God or by strike, lockout, or similar labor disturbances, the time for Consultant's performance of this Agreement shall be extended by a number of days equal to the number of days Consultant has been delayed.

8. Extra or Changed Work. Extra or changed work or other changes to the Agreement may be authorized only by written amendment to this Agreement, signed by both parties. Minor changes, which do not exceed the delegated signature authority of the Department Head and which do not significantly change the scope of work or significantly lengthen time schedules may be executed by the Department Head in a form approved by County Counsel. The Board of Supervisors/Purchasing Agent must authorize all other extra or changed work. The parties expressly recognize that, pursuant to Sonoma County Code Section 1-11, County personnel are without authorization to order extra or changed work or waive Agreement requirements. Failure of Consultant to secure such written authorization for extra or changed work shall constitute a waiver of any and all right to adjustment in the Agreement price or Agreement time due to such unauthorized work and thereafter Consultant shall be entitled to no compensation whatsoever for the performance of such work. Consultant further expressly waives any and all right or remedy by way of restitution and quantum meruit for any and all extra work performed without such express and prior written authorization of the County.

9. Representations of Consultant.

9.1 Standard of Care. County has relied upon the professional ability and training of Consultant as a material inducement to enter into this Agreement. Consultant hereby agrees that all its work will be performed and that its operations shall be conducted in accordance with generally accepted and applicable professional practices and standards as well as the requirements of applicable federal, state and local laws, it being understood that acceptance of Consultant's work by County shall not operate as a waiver or release.

9.2 Status of Consultant. The parties intend that Consultant, in performing the services specified herein, shall act as an independent contractor and shall control the work and the manner in which it is performed. Consultant is not to be considered an agent or employee of County and is not entitled to participate in any pension plan, worker's compensation plan, insurance, bonus, or similar benefits County provides its employees. In the event County exercises its right to terminate this Agreement pursuant to Article 4, above, Consultant expressly agrees that it shall have no recourse or right of appeal under rules, regulations, ordinances, or laws applicable to employees.

9.3 No Suspension or Debarment. Consultant warrants that it is not presently debarred, suspended, proposed for debarment, declared ineligible, or voluntarily excluded from participation in covered transactions by any federal department or agency. Consultant also warrants that it is not suspended or debarred from receiving federal funds as listed in the List of Parties Excluded from

Federal Procurement or Non-procurement Programs issued by the General Services Administration. If the Consultant becomes debarred, consultant has the obligation to inform the County.

9.4 Taxes. Consultant agrees to file federal and state tax returns and pay all applicable taxes on amounts paid pursuant to this Agreement and shall be solely liable and responsible to pay such taxes and other obligations, including, but not limited to, state and federal income and FICA taxes. Consultant agrees to indemnify and hold County harmless from any liability which it may incur to the United States or to the State of California as a consequence of Consultant's failure to pay, when due, all such taxes and obligations. In case County is audited for compliance regarding any withholding or other applicable taxes, Consultant agrees to furnish County with proof of payment of taxes on these earnings.

9.5 Records Maintenance. Consultant shall keep and maintain full and complete documentation and accounting records concerning all services performed that are compensable under this Agreement and shall make such documents and records available to County for inspection at any reasonable time. Consultant shall maintain such records for a period of four (4) years following completion of work hereunder.

9.6 Conflict of Interest. Consultant covenants that it presently has no interest and that it will not acquire any interest, direct or indirect, that represents a financial conflict of interest under state law or that would otherwise conflict in any manner or degree with the performance of its services hereunder. Consultant further covenants that in the performance of this Agreement no person having any such interests shall be employed. In addition, if requested to do so by County, Consultant shall complete and file and shall require any other person doing work under this Agreement to complete and file a "Statement of Economic Interest" with County disclosing Consultant's or such other person's financial interests.

9.7 Statutory Compliance/Living Wage Ordinance. Consultant agrees to comply, and to ensure compliance by its sub-consultants or subcontractors, with all applicable federal, state and local laws, regulations, statutes and policies, including but not limited to the County of Sonoma Living Wage Ordinance, applicable to the services provided under this Agreement as they exist now and as they are changed, amended or modified during the term of this Agreement. Without limiting the generality of the foregoing, Consultant expressly acknowledges and agrees that this Agreement may be subject to the provisions of Article XXVI of Chapter 2 of the Sonoma County Code, requiring payment of a living wage to covered employees. Noncompliance during the term of the Agreement will be considered a material breach and may result in termination of the Agreement or pursuit of other legal or administrative remedies.

9.8 Nondiscrimination. Without limiting any other provision hereunder, Consultant shall comply with all applicable federal, state, and local laws, rules, and regulations in regard to nondiscrimination in employment because of race, color, ancestry, national origin, religion, sex, marital status, age, medical condition, pregnancy, disability, sexual orientation or other prohibited basis, including without limitation, the County's Non-Discrimination Policy. All nondiscrimination rules or regulations required by law to be included in this Agreement are incorporated herein by this reference.

9.9 AIDS Discrimination. Consultant agrees to comply with the provisions of Chapter 19, Article II, of the Sonoma County Code prohibiting discrimination in housing, employment, and

services because of AIDS or HIV infection during the term of this Agreement and any extensions of the term.

9.10 Assignment of Rights. Consultant assigns to County all rights throughout the world in perpetuity in the nature of copyright, trademark, patent, right to ideas, in and to all versions of the plans and specifications, if any, now or later prepared by Consultant in connection with this Agreement. Consultant agrees to take such actions as are necessary to protect the rights assigned to County in this Agreement, and to refrain from taking any action which would impair those rights. Consultant's responsibilities under this provision include, but are not limited to, placing proper notice of copyright on all versions of the plans and specifications as County may direct, and refraining from disclosing any versions of the plans and specifications to any third party without first obtaining written permission of County. Consultant shall not use or permit another to use the plans and specifications in connection with this or any other project without first obtaining written permission of County.

9.11 Ownership and Disclosure of Work Product. All reports, original drawings, graphics, plans, studies, and other data or documents ("documents"), in whatever form or format, assembled or prepared by Consultant or Consultant's subcontractors, consultants, and other agents in connection with this Agreement shall be the property of County. County shall be entitled to immediate possession of such documents upon completion of the work pursuant to this Agreement. Upon expiration or termination of this Agreement, Consultant shall promptly deliver to County all such documents, which have not already been provided to County in such form or format, as County deems appropriate. Such documents shall be and will remain the property of County without restriction or limitation. Consultant may retain copies of the above- described documents but agrees not to disclose or discuss any information gathered, discovered, or generated in any way through this Agreement without the express written permission of County.

9.12 Authority. The undersigned hereby represents and warrants that he or she has authority to execute and deliver this Agreement on behalf of Consultant.

10. Demand for Assurance. Each party to this Agreement undertakes the obligation that the other's expectation of receiving due performance will not be impaired. When reasonable grounds for insecurity arise with respect to the performance of either party, the other may in writing demand adequate assurance of due performance and until such assurance is received may, if commercially reasonable, suspend any performance for which the agreed return has not been received. "Commercially reasonable" includes not only the conduct of a party with respect to performance under this Agreement, but also conduct with respect to other agreements with parties to this Agreement or others. After receipt of a justified demand, failure to provide within a reasonable time, but not exceeding thirty (30) days, such assurance of due performance as is adequate under the circumstances of the particular case is a repudiation of this Agreement. Acceptance of any improper delivery, service, or payment does not prejudice the aggrieved party's right to demand adequate assurance of future performance. Nothing in this Article limits County's right to terminate this Agreement pursuant to Article 4.

11. Assignment and Delegation. Neither party hereto shall assign, delegate, sublet, or transfer any interest in or duty under this Agreement without the prior written consent of the other, and no such transfer shall be of any force or effect whatsoever unless and until the other party shall have so consented.

12. Method and Place of Giving Notice, Submitting Bills and Making Payments. All notices, bills, and payments shall be made in writing and shall be given by personal delivery or by U.S. Mail or courier service. Notices, bills, and payments shall be addressed as follows:

TO: COUNTY: Mr. Jon Stout
Charles M. Schulz – Sonoma County Airport
2290 Airport Boulevard
Santa Rosa, CA 95403
PH: 707-565-7243 FAX: 707-542-5303
Email: jon.stout@sonoma-county.org

TO: CONSULTANT: Mr. Joe Jackson, Vice President
RS&H California, Inc.
369 Pine St., Suite 610
San Francisco, CA 94104
Email: joe.jackson@rsandh.com

When a notice, bill or payment is given by a generally recognized overnight courier service, the notice, bill or payment shall be deemed received on the next business day. When a copy of a notice, bill or payment is sent by facsimile or email, the notice, bill or payment shall be deemed received upon transmission as long as (1) the original copy of the notice, bill or payment is promptly deposited in the U.S. mail and postmarked on the date of the facsimile or email (for a payment, on or before the due date), (2) the sender has a written confirmation of the facsimile transmission or email, and (3) the facsimile or email is transmitted before 5 p.m. (recipient's time). In all other instances, notices, bills and payments shall be effective upon receipt by the recipient. Changes may be made in the names and addresses of the person to whom notices are to be given by giving notice pursuant to this paragraph.

13. Federal Contract Provisions

13.1 Access to Records and Reports

The Consultant must maintain an acceptable cost accounting system. The Contractor agrees to provide the sponsor, the Federal Aviation Administration, and the Comptroller General of the United States or any of their duly authorized representatives, access to any books, documents, papers, and records of the contractor which are directly pertinent to the specific contract for the purpose of making audit, examination, excerpts and transcriptions. The Consultant agrees to maintain all books, records and reports required under this contract for a period of not less than three years after final payment is made and all pending matters are closed.

13.2 Breach of Contract Terms

Any violation or breach of terms of this contract on the part of the contractor or its subcontractors may result in the suspension or termination of this contract or such other action that may be necessary to enforce the rights of the parties of this agreement.

Owner will provide Consultant written notice that describes the nature of the breach and corrective actions the Consultant must undertake in order to avoid termination of the contract. Owner reserves the right to withhold payments to Contractor until such time the Contractor corrects the breach or the Owner elects to terminate the contract. The Owner's notice will identify a specific date by which the Consultant must correct the breach. Owner may proceed with termination of the contract if the Consultant fails to correct the breach by deadline indicated in the Owner's notice.

The duties and obligations imposed by the Contract Documents and the rights and remedies available thereunder are in addition to, and not a limitation of, any duties, obligations, rights and remedies otherwise imposed or available by law.

13.3 Civil Rights - General

The contractor agrees to comply with pertinent statutes, Executive Orders and such rules as are promulgated to ensure that no person shall, on the grounds of race, creed, color, national origin, sex, age, or disability be excluded from participating in any activity conducted with or benefiting from Federal assistance.

This provision binds the contractor and sub-tier contractors from the bid solicitation period through the completion of the contract. This provision is in addition to that required of Title VI of the Civil Rights Act of 1964.

13.4 Civil Rights – Title VI Assurance

13.4.1 Compliance with Nondiscrimination Requirements

During the performance of this contract, the contractor, for itself, its assignees, and successors in interest (hereinafter referred to as the “contractor”) agrees as follows:

13.4.1.1 Compliance with Regulations: The contractor (hereinafter includes consultants) will comply with the Title VI List of Pertinent Nondiscrimination Acts And Authorities, as they may be amended from time to time, which are herein incorporated by reference and made a part of this contract.

13.4.1.2 Non-discrimination: The contractor, with regard to the work performed by it during the contract, will not discriminate on the grounds of race, color, or national origin in the selection and retention of subcontractors, including procurements of materials and leases of equipment. The contractor will not participate directly or indirectly in the discrimination prohibited by the Nondiscrimination Acts and Authorities, including employment practices when the contract covers any activity, project, or program set forth in Appendix B of 49 CFR part 21.

13.4.1.3 Solicitations for Subcontracts, Including Procurements of Materials and Equipment: In all solicitations, either by competitive bidding, or negotiation made by the contractor for work to be performed under a subcontract, including procurements of materials, or leases of equipment, each potential subcontractor or supplier will be notified by the contractor of the contractor’s obligations under this contract and the Nondiscrimination Acts And Authorities on the grounds of race, color, or national origin.

13.4.1.4 Information and Reports: The contractor will provide all information and reports required by the Acts, the Regulations, and directives issued pursuant thereto and will permit access to its books, records, accounts, other sources of information, and its facilities as may be determined by the sponsor or the Federal Aviation Administration to be pertinent to ascertain compliance with such Nondiscrimination Acts And Authorities and instructions. Where any information required of a contractor is in the exclusive possession of another who fails or refuses to furnish the information, the contractor will so certify to the sponsor or the Federal

Aviation Administration, as appropriate, and will set forth what efforts it has made to obtain the information.

13.4.1.5 Sanctions for Noncompliance: In the event of a contractor's noncompliance with the Non-discrimination provisions of this contract, the sponsor will impose such contract sanctions as it or the Federal Aviation Administration may determine to be appropriate, including, but not limited to:

- a. Withholding payments to the contractor under the contract until the contractor complies; and/or
- b. Cancelling, terminating, or suspending a contract, in whole or in part.

13.4.1.6 Incorporation of Provisions: The contractor will include the provisions of paragraphs one through six in every subcontract, including procurements of materials and leases of equipment, unless exempt by the Acts, the Regulations and directives issued pursuant thereto. The contractor will take action with respect to any subcontract or procurement as the sponsor or the Federal Aviation Administration may direct as a means of enforcing such provisions including sanctions for noncompliance. Provided, that if the contractor becomes involved in, or is threatened with litigation by a subcontractor, or supplier because of such direction, the contractor may request the sponsor to enter into any litigation to protect the interests of the sponsor. In addition, the contractor may request the United States to enter into the litigation to protect the interests of the United States.

13.4.2 Title VI List of Pertinent Nondiscrimination Acts and Authorities

During the performance of this contract, the contractor, for itself, its assignees, and successors in interest (hereinafter referred to as the "contractor") agrees to comply with the following non-discrimination statutes and authorities; including but not limited to:

- Title VI of the Civil Rights Act of 1964 (42 U.S.C. § 2000d *et seq.*, 78 stat. 252), (prohibits discrimination on the basis of race, color, national origin);
- 49 CFR part 21 (Non-discrimination In Federally-Assisted Programs of The Department of Transportation—Effectuation of Title VI of The Civil Rights Act of 1964);
- The Uniform Relocation Assistance and Real Property Acquisition Policies Act of 1970, (42 U.S.C. § 4601), (prohibits unfair treatment of persons displaced or whose property has been acquired because of Federal or Federal-aid programs and projects);
- Section 504 of the Rehabilitation Act of 1973, (29 U.S.C. § 794 *et seq.*), as amended, (prohibits discrimination on the basis of disability); and 49 CFR part 27;
- The Age Discrimination Act of 1975, as amended, (42 U.S.C. § 6101 *et seq.*), (prohibits discrimination on the basis of age);
- Airport and Airway Improvement Act of 1982, (49 USC § 471, Section 47123), as amended, (prohibits discrimination based on race, creed, color, national origin, or sex);

- The Civil Rights Restoration Act of 1987, (PL 100-209), (Broadened the scope, coverage and applicability of Title VI of the Civil Rights Act of 1964, The Age Discrimination Act of 1975 and Section 504 of the Rehabilitation Act of 1973, by expanding the definition of the terms “programs or activities” to include all of the programs or activities of the Federal-aid recipients, sub-recipients and contractors, whether such programs or activities are Federally funded or not);
- Titles II and III of the Americans with Disabilities Act of 1990, which prohibit discrimination on the basis of disability in the operation of public entities, public and private transportation systems, places of public accommodation, and certain testing entities (42 U.S.C. §§ 12131 – 12189) as implemented by Department of Transportation regulations at 49 CFR parts 37 and 38;
- The Federal Aviation Administration’s Non-discrimination statute (49 U.S.C. § 47123) (prohibits discrimination on the basis of race, color, national origin, and sex);
- Executive Order 12898, Federal Actions to Address Environmental Justice in Minority Populations and Low-Income Populations, which ensures non-discrimination against minority populations by discouraging programs, policies, and activities with disproportionately high and adverse human health or environmental effects on minority and low-income populations;
- Executive Order 13166, Improving Access to Services for Persons with Limited English Proficiency, and resulting agency guidance, national origin discrimination includes discrimination because of limited English proficiency (LEP). To ensure compliance with Title VI, you must take reasonable steps to ensure that LEP persons have meaningful access to your programs (70 Fed. Reg. at 74087 to 74100);
- Title IX of the Education Amendments of 1972, as amended, which prohibits you from discriminating because of sex in education programs or activities (20 U.S.C. 1681 et seq).

13.5 Clean Air and Water Control

Consultant agrees to comply with all applicable standards, orders, and regulations issued pursuant to the Clean Air Act (42 U.S.C. § 740-7671q) and the Federal Water Pollution Control Act as amended (33 U.S.C. § 1251-1387). The Consultant agrees to report any violation to the Owner immediately upon discovery. The Owner assumes responsibility for notifying the Environmental Protection Agency (EPA) and the Federal Aviation Administration.

Consultant must include this requirement in all subcontracts that exceed \$150,000.

13.6 Disadvantaged Business Enterprise

Contract Assurance (§ 26.13) - The Consultant or sub-consultant shall not discriminate on the basis of race, color, national origin, or sex in the performance of this contract. The Consultant shall carry out applicable requirements of 49 CFR Part 26 in the award and administration of DOT assisted contracts. Failure by the Consultant to carry out these requirements is a material breach of this contract, which may result in the termination of this contract or such other remedy, as the recipient deems appropriate.

Prompt Payment (§26.29) - The prime Contractor agrees to pay each subcontractor under this prime contract for satisfactory performance of its contract no later than thirty (30) days from the receipt of each payment the prime Contractor receives from the County. The prime Contractor agrees further to return retainage payments to each subcontractor within thirty (30) days after the subcontractor's work is satisfactorily completed. Any delay or postponement of payment from the above referenced time frame may occur only for good cause following written approval of the County. This clause applies to both DBE and non-DBE subcontractors.

13.6.1 Race/Gender Neutral Language

The requirements of 49 CFR part 26 apply to this contract. It is the policy of the [Insert Name of Owner] to practice nondiscrimination based on race, color, sex or national origin in the award or performance of this contract. The Owner encourages participation by all firms qualifying under this solicitation regardless of business size or ownership.

13.6.2 Any subcontract entered into as a result of this contract shall contain all of the provisions of this section. Consultant shall submit copies of all sub-consultant agreements to the DBE Liaison Officer within 10 business days of execution.

13.6.3 Consultant shall maintain records of materials purchased or supplied from all subcontracts entered into with certified DBEs. The records shall show the name and business address of each DBE or vendor and the total dollar amount actually paid each DBE or vendor, regardless of tier. The records shall show the date of payment and the total dollar figure paid to all firms. DBE prime consultants shall also show the date of work performed by their own forces along with the corresponding dollar value of the work. The Subcontractor Payment form Exhibit C must be submitted with each invoice.

13.7 Distracted Driving

In accordance with Executive Order 13513, "Federal Leadership on Reducing Text Messaging While Driving" (10/1/2009) and DOT Order 3902.10 "Text Messaging While Driving" (12/30/2009), the FAA encourages recipients of Federal grant funds to adopt and enforce safety policies that decrease crashes by distracted drivers, including policies to ban text messaging while driving when performing work related to a grant or sub-grant.

In support of this initiative, the Owner encourages the Consultant to promote policies and initiatives for its employees and other work personnel that decrease crashes by distracted drivers, including policies that ban text messaging while driving motor vehicles while performing work activities associated with the project. The Consultant must include the substance of this clause in all sub-tier contracts exceeding \$3,500 and involve driving a motor vehicle in performance of work activities associated with the project.

13.8 Energy Conservation Requirements

Consultant and Subcontractor agree to comply with mandatory standards and policies relating to energy efficiency as contained in the state energy conservation plan issued in compliance with the Energy Policy and Conservation Act (42 U.S.C. 6201 *et seq.*).

13.9 Federal Fair Labor Standards Act (FEDERAL MINIMUM WAGE)

All contracts and subcontracts that result from this solicitation incorporate by reference the provisions of 29 CFR part 201, the Federal Fair Labor Standards Act (FLSA), with the same

force and effect as if given in full text. The FLSA sets minimum wage, overtime pay, recordkeeping, and child labor standards for full and part time workers.

The Consultant has full responsibility to monitor compliance to the referenced statute or regulation. The Consultant must address any claims or disputes that arise from this requirement directly with the U.S. Department of Labor – Wage and Hour Division.

13.10 Lobbying and Influencing Federal Employees

The bidder or offeror certifies by signing and submitting this bid or proposal, to the best of his or her knowledge and belief, that:

(1) No Federal appropriated funds have been paid or will be paid, by or on behalf of the Bidder or Offeror, to any person for influencing or attempting to influence an officer or employee of an agency, a Member of Congress, an officer or employee of Congress, or an employee of a Member of Congress in connection with the awarding of any Federal contract, the making of any Federal grant, the making of any Federal loan, the entering into of any cooperative agreement, and the extension, continuation, renewal, amendment, or modification of any Federal contract, grant, loan, or cooperative agreement.

(2) If any funds other than Federal appropriated funds have been paid or will be paid to any person for influencing or attempting to influence an officer or employee of any agency, a Member of Congress, an officer or employee of Congress, or an employee of a Member of Congress in connection with this Federal contract, grant, loan, or cooperative agreement, the undersigned shall complete and submit Standard Form-LLL, “Disclosure Form to Report Lobbying,” in accordance with its instructions.

(3) The undersigned shall require that the language of this certification be included in the award documents for all sub-awards at all tiers (including subcontracts, sub-grants, and contracts under grants, loans, and cooperative agreements) and that all sub-recipients shall certify and disclose accordingly.

This certification is a material representation of fact upon which reliance was placed when this transaction was made or entered into. Submission of this certification is a prerequisite for making or entering into this transaction imposed by section 1352, title 31, U.S. Code. Any person who fails to file the required certification shall be subject to a civil penalty of not less than \$10,000 and not more than \$100,000 for each such failure.

13.11 Occupational Safety and Health Act of 1970

All contracts and subcontracts that result from this solicitation incorporate by reference the requirements of 29 CFR Part 1910 with the same force and effect as if given in full text. Consultant must provide a work environment that is free from recognized hazards that may cause death or serious physical harm to the employee. The Consultant retains full responsibility to monitor its compliance and their subcontractor’s compliance with the applicable requirements of the Occupational Safety and Health Act of 1970 (20 CFR Part 1910). Consultant must address any claims or disputes that pertain to a referenced requirement directly with the U.S. Department of Labor – Occupational Safety and Health Administration.

13.12 Termination of Contract

13.12.1 Termination for Convenience

The Owner may, by written notice to the Consultant, terminate this Agreement for its convenience and without cause or default on the part of Consultant. Upon receipt of the notice of termination, except as explicitly directed by the Owner, the Consultant must immediately discontinue all services affected.

Upon termination of the Agreement, the Consultant must deliver to the Owner all data, surveys, models, drawings, specifications, reports, maps, photographs, estimates, summaries, and other documents and materials prepared by the Engineer under this contract, whether complete or partially complete.

Owner agrees to make just and equitable compensation to the Consultant for satisfactory work completed up through the date the Consultant receives the termination notice. Compensation will not include anticipated profit on non-performed services.

Owner further agrees to hold Consultant harmless for errors or omissions in documents that are incomplete as a result of the termination action under this clause.

13.12.2 Termination for Default

Either party may terminate this Agreement for cause if the other party fails to fulfill its obligations that are essential to the completion of the work per the terms and conditions of the Agreement. The party initiating the termination action must allow the breaching party an opportunity to dispute or cure the breach.

The terminating party must provide the breaching party [7] days advance written notice of its intent to terminate the Agreement. The notice must specify the nature and extent of the breach, the conditions necessary to cure the breach, and the effective date of the termination action. The rights and remedies in this clause are in addition to any other rights and remedies provided by law or under this agreement.

- a) Termination by Owner: The Owner may terminate this Agreement in whole or in part, for the failure of the Consultant to:
 1. Perform the services within the time specified in this contract or by Owner approved extension;
 2. Make adequate progress so as to endanger satisfactory performance of the Project;
 3. Fulfill the obligations of the Agreement that are essential to the completion of the Project.

Upon receipt of the notice of termination, the Consultant must immediately discontinue all services affected unless the notice directs otherwise. Upon termination of the Agreement, the Consultant must deliver to the Owner all data, surveys, models, drawings, specifications, reports, maps, photographs, estimates, summaries, and other documents and materials prepared by the Engineer under this contract, whether complete or partially complete.

Owner agrees to make just and equitable compensation to the Consultant for satisfactory work completed up through the date the Consultant receives the termination notice. Compensation will not include anticipated profit on non-performed services.

Owner further agrees to hold Consultant harmless for errors or omissions in documents that are incomplete as a result of the termination action under this clause.

If, after finalization of the termination action, the Owner determines the Consultant was not in default of the Agreement, the rights and obligations of the parties shall be the same as if the Owner issued the termination for the convenience of the Owner.

b) Termination by Consultant: The Consultant may terminate this Agreement in whole or in part, if the Owner:

1. Defaults on its obligations under this Agreement;
2. Fails to make payment to the Consultant in accordance with the terms of this Agreement;
3. Suspends the Project for more than [180] days due to reasons beyond the control of the Consultant.

Upon receipt of a notice of termination from the Consultant, Owner agrees to cooperate with Consultant for the purpose of terminating the agreement or portion thereof, by mutual consent. If Owner and Consultant cannot reach mutual agreement on the termination settlement, the Consultant may, without prejudice to any rights and remedies it may have, proceed with terminating all or parts of this Agreement based upon the Owner's breach of the contract.

In the event of termination due to Owner breach, the Engineer is entitled to invoice Owner and to receive full payment for all services performed or furnished in accordance with this Agreement and all justified reimbursable expenses incurred by the Consultant through the effective date of termination action. Owner agrees to hold Consultant harmless for errors or omissions in documents that are incomplete as a result of the termination action under this clause.

13.13 Trade Restriction Certification

By submission of an offer, the Offeror certifies that with respect to this solicitation and any resultant contract, the Offeror -

- a. is not owned or controlled by one or more citizens of a foreign country included in the list of countries that discriminate against U.S. firms as published by the Office of the United States Trade Representative (U.S.T.R.);
- b. has not knowingly entered into any contract or subcontract for this project with a person that is a citizen or national of a foreign country included on the list of countries that discriminate against U.S. firms as published by the U.S.T.R.; and
- c. has not entered into any subcontract for any product to be used on the Federal on the project that is produced in a foreign country included on the list of countries that discriminate against U.S. firms published by the U.S.T.R.

This certification concerns a matter within the jurisdiction of an agency of the United States of America and the making of a false, fictitious, or fraudulent certification may render the maker subject to prosecution under Title 18, United States Code, Section 1001.

The Offeror/Consultant must provide immediate written notice to the Owner if the Offeror/Consultant learns that its certification or that of a subcontractor was erroneous when submitted or has become erroneous by reason of changed circumstances. The Contractor must require subcontractors provide immediate written notice to the Consultant if at any time it learns that its certification was erroneous by reason of changed circumstances.

Unless the restrictions of this clause are waived by the Secretary of Transportation in accordance with 49 CFR 30.17, no contract shall be awarded to an Offeror or subcontractor:

- (1) who is owned or controlled by one or more citizens or nationals of a foreign country included on the list of countries that discriminate against U.S. firms published by the U.S.T.R. or
- (2) whose subcontractors are owned or controlled by one or more citizens or nationals of a foreign country on such U.S.T.R. list or
- (3) who incorporates in the public works project any product of a foreign country on such U.S.T.R. list;

Nothing contained in the foregoing shall be construed to require establishment of a system of records in order to render, in good faith, the certification required by this provision. The knowledge and information of a Consultant is not required to exceed that which is normally possessed by a prudent person in the ordinary course of business dealings.

The Offeror agrees that, if awarded a contract resulting from this solicitation, it will incorporate this provision for certification without modification in all lower tier subcontracts. The Consultant may rely on the certification of a prospective subcontractor that it is not a firm from a foreign country included on the list of countries that discriminate against U.S. firms as published by U.S.T.R, unless the Offeror has knowledge that the certification is erroneous.

This certification is a material representation of fact upon which reliance was placed when making an award. If it is later determined that the Consultant or subcontractor knowingly rendered an erroneous certification, the Federal Aviation Administration may direct through the Owner cancellation of the contract or subcontract for default at no cost to the Owner or the FAA.

13.14 Veteran's Preference

In the employment of labor (excluding executive, administrative, and supervisory positions), the Consultant and all sub-tier Consultants must give preference to covered veterans as defined within Title 49 United States Code Section 47112. Covered veterans include Vietnam-era veterans, Persian Gulf veterans, Afghanistan-Iraq war veterans, disabled veterans, and small business concerns (as defined by 15 U.S.C. 632) owned and controlled by disabled veterans. This preference only applies when there are covered veterans readily available and qualified to perform the work to which the employment relates.

14. Prevailing Wages

14.1 General. Consultant shall pay to persons performing mowing or landscaping hereunder an amount equal to or more than the general prevailing rate of per diem wages for (1) work of a

similar character in the locality in which the work is performed and (2) legal holiday and overtime work in said locality. The per diem wages shall be an amount equal to or more than the stipulated rates contained in a schedule that has been ascertained and determined by the Director of the State Department of Industrial Relations and County to be the general prevailing rate of per diem wages for each craft or type of workman or mechanic needed to execute this Agreement. Consultant shall also cause a copy of this determination of the prevailing rate of per diem wages to be posted at each site work is being performed. Copies of the prevailing wage rate of per diem wages are on file at the Department of Transportation and Public Works – Airport Division and will be made available to any person upon request.

14.2 Subcontracts. Consultant shall insert in every subcontract or other arrangement which Consultant may make for performance of such work or labor on work provided for in the Agreement, provision that Subcontractor shall pay persons performing labor or rendering service under subcontract or other arrangement not less than the general prevailing rate of per diem wages for work of a similar character in the locality in which the work is performed, and not less than the general prevailing rate of per diem wages for holiday and overtime work fixed in the Labor Code. Pursuant to Labor Code Section 1775(b)(1), Consultant shall provide to each Subcontractor a copy of Sections 1771, 1775, 1776, 1777.5, 1813 and 1815 of the Labor Code.

14.3 Compliance Monitoring and Registration: This work specified above is subject to compliance monitoring and enforcement by the Department of Industrial Relations. Consultant shall furnish and shall require all subcontractors to furnish the records specified in Labor Code section 1776 (e.g. electronic certified payroll records) directly to the Labor Commissioner in a format prescribed by the Labor Commissioner at least monthly (Labor Code 1771.4 (a)(3)). Consultant and all subcontractors performing work that requires payment of prevailing wages shall be registered and qualified to perform public work pursuant to Labor Code section 1725.5 as a condition to engage in the performance of any services under this Agreement.

14.4 Compliance With Law. In addition to the above, Consultant stipulates that it shall comply with all applicable wage and hour laws, including without limitation Labor Code Sections 1725.5, 1775, 1776, 1777.5 1813 and 1815 and California Code of Regulations, Title 8, Section 16000, et seq.

15. Miscellaneous Provisions.

15.1 No Waiver of Breach. The waiver by County of any breach of any term or promise contained in this Agreement shall not be deemed to be a waiver of such term or provision or any subsequent breach of the same or any other term or promise contained in this Agreement.

15.2 Construction. To the fullest extent allowed by law, the provisions of this Agreement shall be construed and given effect in a manner that avoids any violation of statute, ordinance, regulation, or law. The parties covenant and agree that in the event that any provision of this Agreement is held by a court of competent jurisdiction to be invalid, void, or unenforceable, the remainder of the provisions hereof shall remain in full force and effect and shall in no way be affected, impaired, or invalidated thereby. Consultant and County acknowledge that they have each contributed to the making of this Agreement and that, in the event of a dispute over the interpretation of this Agreement, the language of the Agreement will not be construed against one party in favor of the other. Consultant and County acknowledge that they have each had an adequate opportunity to consult with counsel in the negotiation and preparation of this Agreement.

15.3 Consent. Wherever in this Agreement the consent or approval of one party is required to an act of the other party, such consent or approval shall not be unreasonably withheld or delayed.

15.4 No Third Party Beneficiaries. Nothing contained in this Agreement shall be construed to create and the parties do not intend to create any rights in third parties.

15.5 Applicable Law and Forum. This Agreement shall be construed and interpreted according to the substantive law of California, regardless of the law of conflicts to the contrary in any jurisdiction. Any action to enforce the terms of this Agreement or for the breach thereof shall be brought and tried in Santa Rosa or the forum nearest to the city of Santa Rosa, in the County of Sonoma.

15.6 Captions. The captions in this Agreement are solely for convenience of reference. They are not a part of this Agreement and shall have no effect on its construction or interpretation.

15.7 Merger. This writing is intended both as the final expression of the Agreement between the parties hereto with respect to the included terms and as a complete and exclusive statement of the terms of the Agreement, pursuant to Code of Civil Procedure Section 1856. Each Party acknowledges that, in entering into this Agreement, it has not relied on any representation or undertaking, whether oral or in writing, other than those which are expressly set forth in this Agreement. No modification of this Agreement shall be effective unless and until such modification is evidenced by a writing signed by both parties.

15.8 Survival of Terms. All express representations, waivers, indemnifications, and limitations of liability included in this Agreement will survive its completion or termination for any reason.

15.9 Time of Essence. Time is and shall be of the essence of this Agreement and every provision hereof.

IN WITNESS WHEREOF, the parties hereto have executed this Agreement as of the Effective Date.

CONSULTANT: RS&H California, Inc.

By: _____

Name: Joe Jackson

Title: Vice President

Date: _____

CERTIFICATES OF INSURANCE ON
FILE WITH AND APPROVED AS TO
SUBSTANCE FOR COUNTY:

APPROVED AS TO FORM FOR COUNTY:

By: _____
County Counsel

Date: _____

By: _____
Chair
Board of Supervisors

Date: _____

ATTEST:

Clerk of the Board of Supervisors

LIST OF EXHIBITS

EXHIBIT A – GENERAL CONDITIONS

EXHIBIT B1 – SCOPE OF WORK – NEPA

EXHIBIT B2 – SCOPE OF WORK - CEQA

EXHIBIT C – SCHEDULE

EXHIBIT D – BUDGET

EXHIBIT E – INSURANCE REQUIREMENTS

GENERAL CONDITIONS
TABLE OF CONTENTS

1 INTERPRETATION OF CONTRACT 1

 1.1 Defined Terms 1

 1.2 Contract Documents 1

 1.3 Precedence Of Documents 1

2 BID PERIOD INVESTIGATIONS AND SUBCONTRACTING 1

 2.1 Investigation Prior To Bidding 1

 2.2 Supplied Information on Underground Existing Conditions 2

 2.3 Supplied Information on Above-Ground Existing Conditions 3

 2.4 Subcontractors 3

3 CONTRACT AWARD AND COMMENCEMENT OF THE WORK 3

 3.1 Time Allowances for Performance of Contract Documents 3

 3.2 Commencement Of Work 4

4 INSURANCE AND INDEMNIFICATION 4

 4.1 Insurance 4

 4.2 Indemnification 4

5 DRAWINGS AND SPECIFICATIONS 5

 5.1 Intent 5

 5.2 Drawing Details 5

 5.3 Interpretation Of Drawings And Specifications 5

 5.4 Checking Of Drawings 6

 5.5 Standards To Apply Where Specifications Are Not Furnished 6

 5.6 Deviation from Specifications and Drawings 6

 5.7 Ownership And Use Of Drawings, Specifications And Contract Documents 6

6 CONSTRUCTION BY COUNTY OR BY SEPARATE CONTRACTORS 6

 6.1 County's Right To Perform Construction And To Award Separate Contracts 6

 6.2 Mutual Responsibility 7

 6.3 County Authority Over Coordination 7

7 PAYMENT BY COUNTY 8

 7.1 Receipt And Processing Of Applications For Payment 8

8 CONTROL OF THE WORK 8

 8.1 Subcontractors 8

 8.2 Supervision Of Work By Contractor 8

 8.3 Observation Of Work By County 8

 8.4 Access To Work 9

9 WARRANTY, GUARANTY, AND INSPECTION OF WORK 10

 9.1 Warranty And Guaranty 10

 9.2 Inspection Of Work 11

 9.3 Correction Of Defective Work 12

 9.4 Acceptance And Correction Of Defective Work By County 13

 9.5 Rights Upon Inspection Or Correction 14

 9.6 Samples And Tests Of Materials And Work 14

 9.7 Proof Of Compliance Of Contract Provisions 14

9.8	Acceptance	14
10	CONTRACTOR'S ORGANIZATION AND EQUIPMENT	14
10.1	Contractor's Legal Address	14
10.2	Contractor's Office At The Work Site	15
10.3	Contractor's Superintendents Or Forepersons	15
10.4	Proficiency In English	15
10.5	Contractor's And Subcontractors' Employees	15
10.6	Contractor To List Trades Working	15
10.7	Contractor's Use Of The Site.....	15
11	PROSECUTION AND PROGRESS OF THE WORK.....	16
11.1	Schedules And Examinations Of Contract Documents.....	16
11.2	Commencement of Work Notification	16
11.3	Submittals	16
11.4	Contractor To Supply Sufficient Workers And Materials	17
11.5	Contractor's Project Data	17
12	CLAIMS BY CONTRACTOR/NON-JUDICIAL SETTLEMENT PROCEDURE	18
12.1	Scope.....	18
12.2	Procedure	19
12.3	Administration During/After Claim Submission.....	Error! Bookmark not defined.
12.4	Mediation	21
12.5	Subcontractor Claims	21
12.6	Waiver.....	22
13	LEGAL AND MISCELLANEOUS.....	22
13.1	Laws And Regulations.....	22
13.2	Permits And Taxes	22
13.3	Suspension Of Work.....	23
13.4	Termination Of Contract For Cause	23
13.5	Termination Of Contract For Convenience.....	25
13.6	Contingent Assignment Of Subcontracts	27
13.7	Remedies and Contract Integration.....	27
13.8	Patents.....	28
13.9	Substitution For Patented And Specified Articles.....	28
13.10	Interest Of Public Officers.....	28
13.11	Limit Of Liability	28
13.12	Severability	28
14	MODIFICATIONS OF CONTRACT DOCUMENTS.....	29
14.1	Alterations, Modifications And Force Account Work	29
14.2	Time Allowances	29
14.3	Notice Of Delay	30
14.4	Non-Compensable Time Extensions; Adverse Weather Parameters	30
14.5	Compensable Time Extensions.....	31
14.6	Liquidated Damages.....	31
14.7	Differing Site Conditions	32
14.8	Change Orders Related to Underground Facilities	33
15	WORKING CONDITIONS AND PREVAILING WAGES	34
15.1	Use Of Site/Sanitary Rules.....	34
15.2	Protection Of Work, Persons, And Property.....	34
15.3	Responsibility For Safety And Health	35
15.4	Emergencies.....	35
15.5	Use Of Roadways And Walkways.....	35

15.6	Nondiscrimination	36
15.7	Prevailing Wages.....	36
15.8	Environmental Controls	37
15.9	Shoring Safety Plan.....	37

GENERAL CONDITIONS

1 INTERPRETATION OF CONTRACT

1.1 Defined Terms

1.1.A. All abbreviations and definitions of terms used and not otherwise defined in this Document 007200 are set forth in Section 014200 (References). This Document 007200 subdivides at first level into Articles, and then into paragraphs.

1.2 Contract Documents

1.2.A. Contract Documents are complementary; what is called for by one is as binding as if called for by all. Contract Documents shall not be construed to create a contractual relationship of any kind between (i) Architect, Engineer or any County's Representative and Contractor; (ii) County and/or its representatives and a Subcontractor, sub-Subcontractor, or supplier of any Project labor, materials, or equipment; or (iii) between any persons or entities other than County and Contractor.

1.3 Precedence Of Documents

1.3.A. In the case of discrepancy or ambiguity in the Contract Documents, the following order of precedence shall prevail:

- 1.3.A.1. Modifications in inverse chronological order (i.e., most recent first), and in the same order as specific portions they are modifying;
- 1.3.A.2. Document 005213 (Agreement Form - Stipulated Sum), and terms and conditions referenced therein;
- 1.3.A.3. Supplementary Conditions;
- 1.3.A.4. General Conditions);
- 1.3.A.5. Division 1 Specifications;
- 1.3.A.6. Drawings and Division 1 through 49 Specifications;
- 1.3.A.7. Written numbers over figures, unless obviously incorrect (i.e. [six] over [6]);
- 1.3.A.8. Figured dimensions over scaled dimensions;
- 1.3.A.9. Large-scale Drawings over small-scale Drawings.

1.3.B. Any conflict between Drawings and Division 1 through 49 Specifications will be resolved in favor of the document of the latest date (i.e., the most recent document), and if the dates are the same or not determinable, then in favor of Specifications.

1.3.C. Any conflict between a bill or list of materials shown in the Contract Documents and the actual quantities required to complete Work required by Contract Documents, will be resolved in favor of the actual quantities.

2 BID PERIOD INVESTIGATIONS AND SUBCONTRACTING

2.1 Investigation Prior To Bidding

2.1.A. Prior to bidding, Contractor must investigate fully the Work of the Contract. Contractor must visit the Site, examine thoroughly and understand fully the nature and extent of the Contract Documents, Work, Site, locality, actual conditions and as-built conditions, and all other information made available for bidding. Contractor's investigation shall include, but is not limited to, a thorough examination of all reports of exploration and tests of subsurface conditions, as-built drawings, drawings, product specification(s) or reports, available for Bidding purposes, of physical conditions, including Underground Facilities and information identified in Document 003119 (Existing Condition Information) and/or Document 003126 (Existing Hazardous Materials Information) (if used), or which may appear in the Contract Documents, and all local conditions, and federal, state and local laws and regulations that in any manner may affect cost, progress, performance or furnishing of Work or which relate to any aspect of the means, methods, techniques, sequences or procedures of construction to be employed by Contractor and safety precautions and programs incident thereto. Contractor shall completely and thoroughly correlate all such information and consider such information fully, prior to and as a condition of submitting its Bid. Contractor shall make inquiry as required in Document 003119 (Existing Condition Information).

2.1.B. Prior to submitting its Bid, Contractor shall take care to note the existence and

potential existence of Underground Facilities, in particular, above and below grade structures, drainage lines, storm drains, sewers, water, gas, electrical, chemical, hot water, and other similar items and utilities. Contractor shall carefully consider all supplied information, request additional information Contractor may deem necessary, and visually inspect the Site for above ground indications of Underground Facilities (such as, for example not by way of limitation, the existence of existing service laterals, appurtenances or other types of utilities, indicated by the presence of an underground transmission main or other visible facilities, such as buildings, new asphalt, meters and junction boxes, on or adjacent to the Site).

- 2.1.C. Prior to submitting its Bid, Contractor must correlate its experience, knowledge and the results of its required investigation with the terms and conditions of the Contract Documents, and must give County prompt written notice of all conflicts, errors, ambiguities, or discrepancies of any type, that it may discover in or among the Contract Documents, as-built drawings (if any) and/or actual conditions. Contractor shall give this notice during the Bid period and submission of a Bid indicates Contractor's agreement that County responded to the notice through Addenda issued by County which is acceptable to Contractor.
- 2.1.D. Prior to submitting its Bid, Contractor must consider fully the fact that information supplied regarding existing Underground Facilities at or contiguous to the Site is in many cases based on information furnished to County by others (e.g., the builders of such Underground Facilities or others), and that due to their age or their chain of custody since preparation, may not meet current industry standards for accuracy. Contractor must also consider local underground conditions and typical practices for Underground Facilities, either through its own direct knowledge or through its subcontractors, and fully consider this knowledge in assessing the existing information and the reasonableness of its reliance.
- 2.1.E. Prior to submitting its Bid, Contractor shall conduct (or request that County have conducted) any such additional or supplementary examinations, investigations, explorations, tests, studies and data concerning conditions (surface, subsurface, and Underground Facilities) at or contiguous to the Site or otherwise, which may affect cost, progress, performance or furnishing of Work or which relate to any aspect of the means, methods, techniques, sequences or procedures of construction to be employed by Contractor and safety precautions and programs incident thereto or which Contractor deems necessary to determine its Bid for performing and furnishing the Work in accordance with the time, price and other terms and conditions of Contract Documents.
- 2.1.F. Prior to submitting its Bid, Contractor may rely on County supplied information regarding existing conditions only where such conditions are underground and not subject to reasonable verification. If existing information supplied by County indicates a discrepancy or a substantial risk of inaccuracy or omission, then Contractor must request specific additional information. Contractor shall advise County in writing during the Bid period of any questions, suppositions, inferences or deductions Contractor may have, for County's review and response by Addenda, and may not assert any such matters later that were not brought forth during the Bid period.
- 2.1.G. During performance of the Contract, Contractor will be charged with knowledge of all information that it should have learned in performing this required pre-Bid investigation, and shall not be entitled to change orders (time or compensation) due to information or conditions that Contractor should have known as a part of this pre-Bid investigation.

2.2 Supplied Information on Underground Existing Conditions

- 2.2.A. Regarding Underground Facilities shown in the Contract Documents or supplied through Document 003119 (Existing Condition Information), County has compiled this information in good faith, relying on its records and third party records. Because of the nature and location of County and the Project, the existence of Underground Facilities is deemed inherent in the Work of the Contract, as is the fact that Underground Facilities are not always accurately shown or completely shown on as-

built records, both as to their depth and location. In Article 14 of this Document 007200, this Contract establishes a heightened standard for claims involving Underground Facilities. Contractor shall consider this fact in its bidding and in its planning and execution of the Work involving Underground Facilities.

- 2.2.B. Regarding subsurface conditions other than Underground Facilities, shown on the Contract Documents or supplied in Document 003119 (Existing Conditions Information), Contractor may rely only upon the general accuracy of actual reported depths, actual reported character of materials, actual reported soil types, actual reported water conditions, or actual obstructions shown or indicated in the Contract Documents. County is not responsible for the completeness of any subsurface condition information for bidding or construction, Contractor's conclusions or opinions drawn from any subsurface condition information, or subsurface conditions that are not specifically shown. (For example, County is not responsible for soil conditions in areas contiguous to areas where a subsurface condition is shown.)

2.3 Supplied Information on Above-Ground Existing Conditions

- 2.3.A. Regarding aboveground and as-built conditions shown on the Contract Documents or supplied through Document 003119 (Existing Condition Information), such information has been compiled in good faith, however, Contractor must independently verify such information. County does not expressly or impliedly warrant or represent that information as to aboveground conditions or as-built conditions indicated in the Contract Documents or Document 003119, is correctly shown or indicated, or otherwise complete for construction purposes.
- 2.3.B. As a condition to bidding, Contractor shall verify by independent investigation all such aboveground and as-built conditions, and bring any discrepancies to County's attention through written question. In submitting its Bid, Contractor shall rely on the results of its own independent investigation and shall not rely on County-supplied information regarding aboveground conditions and as-built conditions, and Contractor shall accept full responsibility for its verification work sufficient to complete the Work as intended.

2.4 Subcontractors

- 2.4.A. Consistent with Public Contract Code Sections 4101 *et seq.*, Contractor shall not substitute any other person or firm in place of any Subcontractor listed in the Bid. Subcontractors shall not assign or transfer their subcontracts or permit them to be performed by any other contractor without County's written approval. At County's request, Contractor shall provide County with a complete copy of all executed subcontracts or final commercial agreements with Subcontractors and/or suppliers.
- 2.4.B. Subcontract agreements shall preserve and protect the rights of County under the Contract Documents so that subcontracting will not prejudice such rights. To the extent of the Work to be performed by a Subcontractor, Contractor shall require the Subcontractor's written agreement (1) to be bound to the terms of Contract Documents and (2) to assume vis-à-vis Contractor all the obligations and responsibilities that Contractor assumes toward County under the Contract Documents. (These agreements include for example, and not by way of limitation, all warranties, claims procedures and rules governing submittals of all types to which Contractor is subject under the Contract Documents.)
- 2.4.C. Contractor shall provide for the assignment to County of all rights any Subcontractor may have against any manufacturer, supplier, or distributor for breach of warranties and guarantees relating to the Work performed by the Subcontractor under the Contract Documents.
- 2.4.D. County shall be deemed to be an intended third-party beneficiary of all Subcontracts (of any tier) for the provision of labor, services, supplies or material to the Project , and each such agreement shall so provide.

3 CONTRACT AWARD AND COMMENCEMENT OF THE WORK

3.1 Time Allowances for Performance of Contract Documents

- 3.1.A. County will make the Award of Contract by issuing a Notice of Award. As a condition

to County signing Document 005213 (Agreement Form – Stipulated Sum), however, Contractor shall deliver to County the executed agreements, forms, bonds and insurance documents required by Document 002113 (Instructions to Bidders) in the required quantities and within the required times.

3.1.B. The Contract Time will commence to run on the date indicated in the Notice to Proceed (Commencement Date).

3.1.C. The total number of Days for completion of the Work under the Contract Documents shall be as provided in Document 005213 (Agreement Form - Stipulated Sum).

3.2 Commencement Of Work

3.2.A. Contractor shall commence work on the Site on the Commencement Date found in the Notice to Proceed (Document 005500). Contractor shall not do any Work at the Site prior to that date.

4 INSURANCE AND INDEMNIFICATION

4.1 Insurance

4.1.A. See Document 007316 (–Insurance Requirements), incorporated herein by this reference.

4.2 Indemnification

4.2.A. County and each of its officers, employees, consultants and agents including, but not limited to the Board, Architect, Engineer and each County's Representative, shall not be liable or accountable in any manner for loss or damage that may happen to any part of the Work; loss or damage to materials or other things used or employed in performing the Work; injury, sickness, disease, or death of any person; or damage to property resulting from any cause whatsoever except their sole negligence, willful misconduct or active negligence, attributable to performance or character of the Work, and Contractor releases all of the foregoing persons and entities from any and all such claims.

4.2.B. To the furthest extent permitted by law (including without limitation California Civil Code Section 2782), Contractor shall assume defense of, and indemnify and hold harmless, County and each of its officers, employees, consultants and agents, including but not limited to the Board, Architect, Engineer and each County's Representative, from claims, suits, actions, losses and liability of every kind, nature and description, including but not limited to claims and fines of regulatory agencies and attorney's fees and consultant's fees, directly or indirectly arising out of, connected with or resulting from performance of the Work, failure to perform the Work, or condition of the Work which is caused in whole or part by any act or omission of Contractor, Subcontractors, anyone directly or indirectly employed by any of them or anyone for whose acts any of them may be liable, regardless of whether it is caused in part by the negligence of County or by any person or entity required to be indemnified hereunder.

4.2.C. With respect to third-party claims against Contractor, Contractor waives any and all rights to any type of express or implied indemnity against County and each of its officers, employees, consultants and agents including, but not limited to County, the Board, Architect, Engineer and each County's Representative.

4.2.D. Approval or purchase of any insurance contracts or policies shall in no way relieve from liability nor limit the liability of Contractor, its Subcontractors of any tier, or the officers or agents of any of them.

4.2.E. To the furthest extent permitted by law (including, without limitation, Civil Code Section 2782), the indemnities, releases of liability and limitations of liability, claims procedures, and limitations of remedy expressed throughout Contract Documents shall apply even in the event of breach of Contract, negligence (active or passive), fault or strict liability of the party(ies) indemnified, released, or limited in liability, and shall survive the termination, rescission, breach, abandonment, or completion of the Work or the terms of the Contract Documents. If Contractor fails to perform any of these defense or indemnity obligations, County may in its discretion back charge Contractor for County's costs and damages resulting therefrom and withhold such

- sums from progress payments or other Contract moneys which may become due.
- 4.2.F. The indemnities in the Contract Documents shall not apply to any indemnified party to the extent of its sole negligence or willful misconduct; nor shall they apply to County or other indemnified party to the extent of its active negligence.
- 4.2.G. Contractor's obligations under this paragraph 4.2 shall survive completion of the Work or termination of the Contract Documents for any reason whatsoever.

5 DRAWINGS AND SPECIFICATIONS

5.1 Intent

- 5.1.A. Drawings and Specifications are intended to describe a functionally complete and operable Project (and all parts thereof) to be constructed in accordance with the requirements of Contract Documents. Contractor shall perform any work, provide services and furnish any materials or equipment that may reasonably be inferred from the requirements of Contract Documents or from prevailing custom or trade usage as being required to produce this intended result. Contractor shall interpret words or phrases used to describe Work (including services), materials, or equipment that have well-known technical or construction industry or trade meaning in accordance with that meaning. Drawings' intent specifically includes the intent to depict construction that complies with all applicable laws, codes and standards.
- 5.1.B. As part of the "Work," Contractor shall provide all labor, materials, equipment, machinery, tools, facilities, services, employee training and testing, hoisting facilities, Shop Drawings, storage, testing, security, transportation, disposal, the securing of all necessary or required field dimensions, the cutting or patching of existing materials, notices, permits, documents, reports, agreements and any other items required or necessary to timely and fully complete Work described and the results intended by Contract Documents and, in particular, Drawings and Specifications. Divisions and Specification Sections and the identification on any Drawings shall not control Contractor in dividing Work among Subcontractors or suppliers or delineating the Work to be performed by any specific trade.
- 5.1.C. Contractor shall perform reasonably implied parts of Work as "incidental work" although absent from Drawings and Specifications. Incidental work includes any work not shown on Drawings or described in Specifications that is necessary or normally or customarily required as a part of the Work shown on Drawings or described in Specifications. Incidental work includes any work necessary or required to make each installation satisfactory, legally operable, functional, and consistent with the intent of Drawings and Specifications or the requirements of Contract Documents including required tasks to be performed under Division 1 of Specifications. Contractor shall perform incidental work without extra cost to County. Incidental work shall be treated as if fully described in Specifications and shown on Drawings, and the expense of incidental work shall be included in price Bid and Contract Sum.

5.2 Drawing Details

- 5.2.A. A typical or representative detail on Drawings shall constitute the standard for workmanship and material throughout corresponding parts of Work. Where necessary, and where reasonably inferable from Drawings, Contractor shall adapt such representative detail for application to such corresponding parts of Work. The details of such adaptation shall be subject to prior approval by County. Repetitive features shown in outline on Drawings shall be in exact accordance with corresponding features completely shown.

5.3 Interpretation Of Drawings And Specifications

- 5.3.A. Should any discrepancy appear or any misunderstanding arise as to the import of anything contained in Drawings and Specifications, or should Contractor have any questions or requests relating to Drawings or Specifications, Contractor shall refer the matter to County, in writing, in accordance with Section 012600 (Contract Modification Procedures). County will issue with reasonable promptness written responses, clarifications or interpretations as County may determine necessary, which shall be consistent with the intent of and be reasonably inferable from Contract

Documents. Such written clarifications or interpretations shall be binding upon Contractor. If Contractor believes that a written response, clarification or interpretation justifies an adjustment in the Contract Sum or Contract Time, Contractor shall give County prompt written notice as provided in Section 012600 (Contract Modification Procedures). If the parties are unable to agree to the amount or extent of the adjustment, if any, then Contractor shall perform the Work in conformance with County's response, clarification, or interpretation and may make a written claim for the adjustment as provided in Article 12 of this Document 007200.

5.4 Checking Of Drawings

5.4.A. Before undertaking each part of Work, Contractor shall carefully study and compare Contract Documents and check and verify pertinent information shown in the Contract Documents and all applicable field conditions and measurements. Contractor shall be responsible for any errors that might have been avoided by such comparison. Contractor shall promptly report to County, in writing, any conflict, error, ambiguity or discrepancy that Contractor may discover. Contractor shall obtain a written interpretation or clarification from County before proceeding with any Work affected thereby. Dimensions shown on Drawings shall be followed; Contractor shall not scale Drawings.

5.5 Standards To Apply Where Specifications Are Not Furnished

5.5.A. The following general specifications shall apply wherever in the Specifications, or in any directions given by County in accordance with or supplementing Specifications, it is provided that Contractor shall furnish materials or manufactured articles or shall do Work for which no detailed specifications are shown. Materials or manufactured articles shall be of the best grade, in quality and workmanship, obtainable in the market from firms of established good reputation. If not ordinarily carried in stock, the materials or manufactured articles shall conform to industry standards for first-class materials or articles of the kind required, with due consideration of the use to which they are to be put. Work shall conform to the usual standards or codes, such as those cited in Section 014200 (References), for first-class work of the kind required. Contractor shall specify in writing to County the materials to be used or Work to be performed under this paragraph 5.5 fourteen (14) Days prior to furnishing such materials or performing such Work.

5.6 Deviation from Specifications and Drawings

5.6.A. Contractor shall perform Work in accordance with Drawings and Specifications. Contractor shall not deviate from Drawings or the dimensions given in the Drawings or the Specifications without County's advance written approval of the proposed deviation.

5.6.B. If County elects to change the Work, all changes in the Contract Documents will be made as set forth in Article 14 of this Document 007200.

5.7 Ownership And Use Of Drawings, Specifications And Contract Documents

5.7.A. Drawings, Specifications and other Contract Documents were prepared for use for Work of Contract Documents only. No part of Contract Documents shall be used for any other construction or for any other purpose except with the written consent of County. Any unauthorized use of Contract Documents is prohibited and at the sole liability of the user.

5.7.B. The County will be issuing the Drawings and Project Manual electronically for the Contractor's use, unless specifically stated otherwise.

6 CONSTRUCTION BY COUNTY OR BY SEPARATE CONTRACTORS

6.1 County's Right To Perform Construction And To Award Separate Contracts

6.1.A. County may perform, with its own forces, construction or operations related to the Project. County may also award separate contracts in connection with other portions of the Project or other construction or operations, on the Site or areas contiguous to the Site, under conditions similar to these Contract Documents, or may have utility owners perform other work. When separate contracts are awarded for different portions of the Project or other construction or operations on the Site, the term

“Contractor” in these Contract Documents shall mean the Contractor herein.

6.2 Mutual Responsibility

- 6.2.A. Contractor shall afford all other contractors, utility owners, and County (if County is performing work with its own forces), proper and safe access to the Site, and reasonable opportunity for the installation and storage of their materials. Contractor shall ensure that the execution of its Work properly connects and coordinates with others' work, and shall cooperate with them to facilitate the progress of the Work.
- 6.2.B. Contractor shall coordinate its Work with the work of other contractors, County, and utility owners. Contractor shall hold coordination meetings with other contractors, County and its representatives, and utility owners as required by Section 013150 (Project Meetings).
- 6.2.C. Unless otherwise provided in the Contract Documents, Contractor shall do all cutting, fitting and patching of the Work that may be required to make its several parts come together properly and integrate with such other work. Contractor shall not endanger any work of other contractors, County or utility owners by cutting, excavating or otherwise altering the work of others and will only cut or alter the work of others with the written consent of County and the others whose work will be affected.
- 6.2.D. Contractor's duties and responsibilities under paragraph 6.2.A of this Document 007200 are for the benefit of County and also for the benefit of such other contractors and utility owners working at the Site to the extent that there are comparable provisions for the benefit of Contractor in the direct contracts between County and such other contractors and utility owners.
- 6.2.E. To the extent that any part of Contractor's Work is to interface with work performed or installed by other contractors, County, or utility owners, Contractor shall inspect and measure the in-place work. Contractor shall promptly report to County in writing any defect in in-place work that will impede or increase the cost of Contractor's interface unless corrected. County will require the entity responsible for the Defective Work to make corrections so as to conform to its contract requirements, or, if the defect is the result of an error or omission in the Contract Documents, issue a Change Order. If Contractor fails to measure, inspect and/or report to County in writing defects that are reasonably discoverable, Contractor shall bear all costs of accomplishing the interface acceptable to County. This provision shall be included in any and all other contracts or subcontracts for Work to be performed where such a conflict could exist.

6.3 County Authority Over Coordination

- 6.3.A. County will have authority over coordination of the activities of multiple contractors in cases where County performs work with its own forces or contracts with others for the performance of other work on the Project, or utilities work on the Site. County may at any time and in its sole discretion, designate a person or entity other than County to have authority over the coordination of the activities among the various contractors. County's authority with respect to coordination of the activities of multiple contractors and utility owners shall not relieve Contractor of its obligation to other contractors and utility owners to coordinate its Work with other contractors and utility owners as specified in paragraph 6.2 of this Document 007200. Contractor shall promptly notify County in writing when another contractor on the Project fails to coordinate its work with the Work of Contract Documents.
- 6.3.B. Contractor shall suspend any part of the Work or carry on the same in such manner as directed by County when such suspension or prosecution is necessary to facilitate the work of other contractors or workers. No damages or claims by Contractor will be allowed if the suspension or Work change is due in whole or in part to Contractor's failure to perform its obligation to coordinate its Work with other contractors, County, and utility owners. Damages or claims will be allowed only to the extent of fault by County if the suspension or Work change is due in whole or in part to another contractor's failure to coordinate its work with Contractor, other contractors, County, and utility owners. County reserves the right to back charge Contractor for any damages or claims incurred by other contractors as a result of Contractor's failure to

perform its obligations to coordinate with other contractors, County, and utility owners. County may deposit the funds retained with a Court of competent jurisdiction pursuant to applicable interpleader procedures and Contractor releases County of further liability regarding such funds.

7 PAYMENT BY COUNTY

7.1 Receipt And Processing Of Applications For Payment

7.1.A. As required by Section 012000 (Price and Payment Procedures), Contractor shall prepare the schedules, submit Applications for Payment and warrant title to all Work covered by each Application for Payment. County will review Contractor's Applications for Payment and make payment thereon, and Contractor shall make payments to Subcontractors, suppliers and others, as required by Section 012000 (Price and Payment Procedures).

8 CONTROL OF THE WORK

8.1 Subcontractors

8.1.A. Contractor is fully responsible for Contractor's own acts and omissions. Contractor is responsible for all acts and omissions of its Subcontractors, suppliers, and other persons and organizations performing or furnishing any of the Work, labor, materials, or equipment under a direct or indirect contract with Contractor. The Contractor may not assign any portion, or any rights hereunder, of the Contract Documents without the County's express written consent or, where applicable, compliance with the Subcontractor Listing Law.

8.2 Supervision Of Work By Contractor

8.2.A. Contractor shall supervise, inspect, and direct Work competently and efficiently, devoting the attention and applying such personal skills and expertise as may be required and necessary to perform Work in accordance with Contract Documents. Contractor shall be solely responsible for and have control and charge of construction means, methods, techniques, sequences and procedures, safety precautions and programs in connection with the Work. Contractor shall be responsible to see that the completed Work complies accurately with Contract Documents.

8.2.B. Contractor shall keep on the Site at all times during Work progress a competent resident Superintendent in conformance with paragraph 10.3.A.

8.3 Observation Of Work By County

8.3.A. County Representatives: County's Representative(s) will have limited authority to act on behalf of County as set forth in the Contract Documents. Except as otherwise provided in these Contract Documents or subsequently identified in writing by County, County will issue all communications to Contractor through County's Representative, and Contractor shall issue all communications to County through County's Representative in a written document delivered to County. Should any direct communications between Contractor and County's consultants, architects or engineers not identified in Article 2 of Document 005213 (Agreement Form - Stipulated Sum) occur during field visits or by telephone, Contractor shall immediately confirm them in a written document copied to County's Representative.

8.3.B. Means and methods of Construction: Subject to those rights specifically reserved in the Contract Documents, County will not supervise, or direct, or have control over, or be responsible for, Contractor's means, methods, techniques, sequences or procedures of construction, or the safety precautions and programs incident thereto, or Contractor's failure to comply with laws and regulations applicable to the furnishing or performance of Work. County will not be responsible for Contractor's failure to perform or furnish the Work in accordance with Contract Documents.

8.3.C. In exercising its responsibilities and authorities under the Contract Documents, County does not assume any duties or responsibilities to any Subcontractor or supplier and does not assume any duty of care to Contractor, Contractor's Subcontractors or suppliers. Except as expressly set forth in the Contract Documents, in exercising their respective responsibilities and authorities under the Contract Documents, neither Architect, Engineer nor any County's Representative

assumes any duties or responsibilities to any Subcontractor, sub-Subcontractor or supplier nor assumes any duty of care to Contractor or any Subcontractor, sub-Subcontractor or suppliers.

- 8.3.D. Work shall be performed under County's general observation and administration. Contractor shall comply with County's directions and instructions in accordance with the terms of Contract Documents, but nothing contained in these General Conditions shall be taken to relieve Contractor of any obligations or liabilities under the Contract Documents. County's failure to review or, upon review, failure to object to any aspect of Work reviewed, shall not be deemed a waiver or approval of any non-conforming aspect of Work.
- 8.3.E. County may engage an independent consultant or architect (collectively for purposes of this paragraph 8.3, "Consultant") to assist in administering the Work. If so engaged, Consultant will advise and consult with County, but will have authority to act on behalf of County only to extent provided in the Contract Documents or as set forth in writing by County. Consultant will not be responsible for and will not have control or charge of construction means, methods, techniques, sequences or procedures, or for safety precautions and programs in connection with Work. Consultant will not be responsible for or have control over the acts or omissions of Contractor, Subcontractors or their agents or employees, or any other persons performing Work.
- 8.3.F. Consultant may review Contractor's Submittals, such as Shop Drawings, Product Data, and Samples, but only for conformance with design concept of Work and with information given in the Contract Documents.
- 8.3.G. Consultant may visit the Site at intervals appropriate to stage of construction to become familiar generally with the progress and quality of Work and to determine in general if Work is proceeding in accordance with Contract Documents. Based on its observations, Consultant may recommend to County that it disapprove or reject Work that Consultant believes to be defective or will not produce a complete Project that conforms to Contract Documents or will prejudice the integrity of the design concept of the completed Project as a functioning whole as indicated by Contract Documents. County will also have authority to require special inspection or testing of Work, whether or not the Work is fabricated, installed or completed.
- 8.3.H. Consultant may conduct inspections to recommend to County the dates that Contractor has achieved Substantial Completion and when the Final Inspection Report can be issued, and will receive and forward to County for review written warranties and related documents required by Contract Documents.

8.4 Access To Work

- 8.4.A. During performance of Work, County and its agents, consultants, and employees may at any time enter upon Work, shops or studios where any part of the Work may be in preparation, or factories where any materials for use in Work are being or are to be manufactured, and Contractor shall provide proper and safe facilities for this purpose, and shall make arrangements with manufacturers to facilitate inspection of their processes and products to such extent as County's interests may require. Other contractors, County workers or utility owners performing work for County may also enter upon Work for all purposes required by their respective contracts. Subject to the rights reserved in the Contract Documents, Contractor shall have sole care, custody, and control of the Site and its Work areas.
- 8.4.B. County may, at any time, and from time to time, during the performance of the Work, enter the Work Site for the for the purpose of installing any necessary work by County labor or other contracts, and for any other purpose in connection with the installation of facilities. In doing so, County shall endeavor not to interfere with Contractor and Contractor shall not interfere with other work being done by or on behalf of County.
- 8.4.C. If, prior to completion and final acceptance of all the Work, County takes possession of any structure or facility (whether completed or otherwise) comprising a portion of the Work with the intent to retain possession thereof (as distinguished from

temporary possession contemplating return to Contractor), then, while County is in possession of the same, Contractor shall be relieved of liability for loss or damage to such structure other than that resulting from Contractor's fault or negligence. Such taking of possession by County shall not relieve Contractor from any provisions of the Contract respecting such structure, other than to the extent specified in the preceding sentence, nor constitute a final acceptance of such structure or facility. See also Section 011000 (Summary).

- 8.4.D. If, following installation of any equipment or facilities furnished by Contractor, defects requiring correction by Contractor are found, County shall have the right to operate such unsatisfactory equipment or facilities and make reasonable use thereof until the equipment or facilities can be shut down for correction of defects without injury to County.

9 WARRANTY, GUARANTY, AND INSPECTION OF WORK

9.1 Warranty And Guaranty

- 9.1.A. General Representations and Warranties: Contractor represents and warrants that it is and will be at all times fully qualified and capable of performing every Phase of the Work and completing Work in accordance with the terms of Contract Documents. Contractor warrants that all construction services shall be performed in accordance with generally accepted professional standards of good and sound construction practices and all requirements of Contract Documents. Contractor warrants that Work, including but not limited to each item of materials and equipment incorporated therein, shall be new, of suitable grade of its respective kind for its intended use, and free from defects in design, architecture and/or engineering, materials, construction and workmanship. Contractor warrants that Work shall conform in all respects with all applicable requirements of federal, state and local laws, applicable construction codes and standards, licenses and permits, Drawings and Specifications and all descriptions set forth therein, and all other requirements of Contract Documents. Contractor shall not be responsible, however, for the negligence of others in the specification of specific equipment, materials, design parameters and means or methods of construction where that is specifically shown and expressly required by Contract Documents.
- 9.1.B. Extended Guarantees: Any guaranty exceeding one year provided by the supplier or manufacturer of any equipment or materials used in the Project shall be extended for such term. Contractor expressly agrees to act as co-guarantor of such equipment and materials and shall supply County with all warranty and guaranty documents relative to equipment and materials incorporated in the Project and guaranteed by their suppliers or manufacturers.
- 9.1.C. Environmental and Toxics Warranty: The covenants, warranties and representations contained in this paragraph 9.1.C. are effective continuously during Contractor's Work on the Project and following cessation of labor for any reason including, but not limited to, Project completion. Contractor covenants, warrants and represents to County that:
- 9.1.C.1. To Contractor's knowledge after due inquiry, no lead or Asbestos-containing materials were installed or discovered in the Project at any time during Contractor's construction thereof. If any lead or Asbestos-containing materials were discovered, Contractor made immediate written disclosure to County.
- 9.1.C.2. To Contractor's knowledge after due inquiry, no electrical transformers, light fixtures with ballasts or other equipment containing PCBs are or were located on the Project at any time during Contractor's construction thereof.
- 9.1.C.3. To Contractor's knowledge after due inquiry, no storage tanks for gasoline or any other toxic substance are or were located on the Project at any time during Contractor's construction thereof. If any such materials were discovered, Contractor made immediate written disclosure to County.

9.1.C.4. Contractor's operations concerning the Project are and were not in violation of any applicable environmental federal, state, or local statute, law or regulation dealing with hazardous materials substances or toxic substances and no notice from any governmental body has been served upon Contractor claiming any violation of any such law, ordinance, code or regulation, or requiring or calling attention to the need for any Work, repairs, construction, alteration, or installation on or in connection with the Project in order to comply with any such laws, ordinances, codes, or regulations, with which Contractor has not complied. If there are any such notices with which Contractor has complied, Contractor shall provide County with copies thereof.

9.2 Inspection Of Work

- 9.2.A. All materials, equipment, and workmanship used in Work shall be subject to inspection and testing at all times during construction and/or manufacture in accordance with the terms of Contract Documents. Work and materials, and manufacture and preparation of materials, from beginning of construction until Final Completion and acceptance of Work, shall be subject to inspection and rejection by County, its agents, representatives or independent contractors retained by County to perform inspection services, or governmental agencies with jurisdictional interests. Contractor shall provide them proper and safe conditions for such access and advise them of Contractor's Site safety procedures and program so that they may comply therewith as applicable. Upon request or where specified, County shall be afforded access for inspection at the source of supply, manufacture or assembly of any item of material or equipment, with reasonable accommodations supplied for making such inspections.
- 9.2.B. Contractor shall give County timely notice of readiness of Work for all required inspections, tests or approvals, and shall cooperate with inspection and testing personnel to facilitate required inspections or tests. Contractor shall also coordinate, schedule and give adequate notice to the appropriate inspection personnel of any Work that can only be inspected as it is placed or assembled (for example, concrete or masonry work), to enable the constant presence of such inspection personnel during such Work.
- 9.2.C. If applicable laws or regulations of any public body having jurisdiction require any Work (or part thereof) specifically to be inspected, tested or approved by an employee or other representative of such public body, Contractor shall assume full responsibility for arranging and obtaining such inspections, tests or approvals, and furnish County with the required certificates of inspection, or approval. County will pay the cost of initial testing and Contractor shall pay all costs in connection with any follow-up or additional testing. Contractor shall also be responsible for arranging and obtaining and shall pay all costs in connection with any inspections, tests or approvals required for the acceptance of materials or equipment to be incorporated in the Work, or of materials, mix designs, or equipment submitted for approval prior to Contractor's purchase thereof for incorporation in the Work. Additionally, in the event that a scheduled inspection is canceled in less than 24 hours notice by Contractor and County incurs costs associated with the cancellation, Contractor will reimburse County for the actual costs of the canceled inspections. The amount will be deducted from payment owed Contractor.
- 9.2.D. If Contractor covers any Work, or the work of others, prior to any required inspection, test or approval without written approval of County, Contractor shall uncover the Work at County's request. Contractor shall bear the expense of uncovering Work and replacing Work.
- 9.2.E. In any case where Contractor covers Work contrary to County's request, Contractor shall uncover Work for County's observation or inspection at County's request. Contractor shall bear the cost of uncovering and re-covering the Work.
- 9.2.F. Whenever required by County, Contractor shall furnish tools, labor and materials necessary to make examination of Work that may be completed or in progress, even

to extent of uncovering or taking down portions of finished Work. Should Work be found unsatisfactory, cost of making examination and of reconstruction shall be borne by Contractor. If Work is found to be satisfactory, County, in manner herein prescribed for paying for alterations, Modifications, and extra Work, except as otherwise herein specified, will pay for examination.

9.2.G. Inspection of the Work by or on behalf of County, or County's failure to do so, shall not under any circumstances be deemed a waiver or approval of any non-conforming aspect of the Work. Contractor shall have an absolute duty, in the absence of a written Change Order signed by County, to perform Work in conformance with the Contract Documents.

9.2.H. Any inspection, evaluation, or test performed by or on behalf of County relating to the Work is solely for the benefit of County, and shall not be relied upon by Contractor. Contractor shall not be relieved of the obligation to perform Work in accordance with the Contract Documents, nor relieved of any guaranty, warranty, or other obligation, as a result of any inspections, evaluations, or tests performed by County, whether or not such inspections, evaluations, or tests are permitted or required under the Contract Documents. Contractor shall be solely responsible for testing and inspecting Work already performed to determine whether such Work is in proper condition to receive later Work.

9.3 Correction Of Defective Work

9.3.A. If Contractor fails to supply sufficient skilled workers, suitable materials or equipment, or to furnish or perform the Work in such a way that the completed Work will conform to Contract Documents, County may order Contractor to replace any Defective Work, or stop any portion of Work to permit County (at Contractor's expense) to replace such Defective Work. These County rights are entirely discretionary on the part of the County, and shall not give rise to any duty on the part of County to exercise the rights for the benefit of Contractor or any other party.

9.3.B. County may direct Contractor to correct any Defective Work or remove it from the Site and replace it with Work that is not Defective and satisfactorily correct or remove and replace any damage to other Work or the work of others resulting from the correction or removal. Contractor shall be responsible for any and all claims, costs, losses and damages caused by or resulting from such correction or removal. When necessary, a deductive Change Order will be issued incorporating the necessary revisions in the Contract Documents with respect to the Work and the Contract Sum. If the parties are unable to agree to the amount of an appropriate decrease in the Contract Sum, County may decide the proper amount or, in its discretion may elect to leave the Contract Sum unchanged and deduct from moneys due Contractor, all such claims, costs, losses and damages caused by or resulting from the correction or removal. If Contractor disagrees with County's calculations, it may make a claim as provided in Article 12 of this Document 007200. County's rights under this paragraph 9.3.B shall be entirely discretionary and, like all other County rights and remedies under the Contract, in addition to any other rights it may have under the Contract Documents or by law.

9.3.C. Correction Period:

9.3.C.1. With respect to equipment and machinery supplied by Contractor and incorporated into the Work, if within one year after the date of Substantial Completion of the portion of the Work incorporating the equipment and/or machinery (or, to the extent expressed by Change Order or Certificate of Substantial Completion, one year after County's written acceptance of such equipment), or such longer period of time as may be prescribed by laws or regulations, or by the terms of Contract Documents (including extended warranties), any equipment or machinery is found to be Defective, Contractor shall promptly, without cost to County and in accordance with County's written instructions, correct such Defective Work.

9.3.C.2. With respect to structures within the Scope of Work, if within one year

after the date of Substantial Completion of the Work, or such longer period of time as may be prescribed by laws or regulations, or by the terms of Contract Documents, any Work is found to be defective, Contractor shall promptly, without cost to County and in accordance with County's written instructions, correct such Defective Work.

- 9.3.D. Contractor shall remove any Defective Work rejected by County and replace it with Work that is not Defective, and satisfactorily correct or remove and replace any damage to other Work or the work of others resulting therefrom. If Contractor fails to promptly comply with the terms of such instructions, or in an emergency where delay would cause serious risk of loss or damage, County may have the Defective Work corrected or the rejected Work removed and replaced.
- 9.3.E. Contractor shall pay for all claims, costs, losses and damages caused by or resulting from such removal and replacement. Where Contractor fails to correct Defective Work, or defects are discovered outside the correction period, County shall have all rights and remedies granted by law.
- 9.3.F. Additionally, in special circumstances where a part of the Work is occupied or a particular item of equipment is placed in continuous service before Substantial Completion of all the Work, the correction period for that part of Work or that item may start to run from an earlier date if so provided by Change Order or Certificate of Substantial Completion.
- 9.3.G. Where Defective Work or rejected Work (and damage to other Work resulting therefrom) has been corrected, removed, or replaced under this provision after the commencement of the correction period, the correction period hereunder with respect to such Work shall be extended for an additional period of one year after such correction or removal and replacement has been satisfactorily completed.
- 9.3.H. If following installation of any Work furnished by Contractor, defects requiring correction by Contractor are found, County shall have the right to operate such Work and make reasonable use thereof until it can be shut down for correction of defects without causing injury to County.

9.4 Acceptance And Correction Of Defective Work By County

- 9.4.A. County may accept Defective Work. Contractor shall pay all claims, costs, losses and damages (including but not limited to staff and Consultant time) attributable to County's evaluation of and determination to accept such Defective Work. If County accepts any Defective Work prior to final payment, a Change Order will be issued incorporating the necessary revisions in the Contract Documents with respect to the Work and the Contract Sum. If the parties are unable to agree to the amount of an appropriate decrease in the Contract Sum, County may deduct from moneys due Contractor, all claims, costs, losses, damages, expenses and liabilities attributable to the Defective Work. If Contractor disagrees with County's calculations, Contractor may make a claim as provided in Article 12 of this Document 007200. If County accepts any Defective Work after final payment, Contractor shall pay to County, an appropriate amount as determined by County.
- 9.4.B. County may correct and remedy deficiency if, after five Days' written notice to Contractor, Contractor fails to correct Defective Work or to remove and replace rejected Work in accordance with paragraph 9.3.B of this Document 007200; or provide a plan for correction of Defective Work acceptable to County; or perform Work in accordance with Contract Documents. In connection with such corrective and remedial action, County may exclude Contractor from all or part of the Site; take possession of all or part of Work and suspend Contractor's Work related thereto; take possession of all or part of Contractor's tools, appliances, construction equipment and machinery at the Site; and incorporate in Work any materials and equipment stored at the Site or for which County has paid Contractor but which are stored elsewhere. Contractor shall allow County, its representatives, agents, employees, and other contractors and Architect's consultants access to the Site to enable County to exercise the rights and remedies under this paragraph 9.4.B. Contractor shall be responsible for all claims, costs, losses, damages, expenses and liabilities incurred or

sustained by County in exercising such rights and remedies. A Change Order will be issued incorporating the necessary revisions in the Contract Documents with respect to Work and the Contract Sum. If the parties are unable to agree to the amount of an appropriate decrease in the Contract Sum, County may deduct from moneys due Contractor, all claims, costs, losses and damages caused by or resulting from the correction or removal. If Contractor disagrees with County's calculations, Contractor may make a claim as provided in Article 12 of this Document 007200.

9.5 Rights Upon Inspection Or Correction

9.5.A. Contractor shall not be allowed an extension of Contract Time because of any delay in the performance of Work attributable to the exercise by County of its rights and remedies under this Article 9. Where County exercises its rights under this Article 9, it retains all other rights it has by law or under the Contract Documents including, but not limited to, the right to terminate for default Contractor's right to proceed with the Work under the Contract Documents and/or make a claim or back charge where a Change Order cannot be agreed upon.

9.5.B. Inspection by County shall not relieve Contractor of its obligation to have furnished material and workmanship in accordance with Contract Documents. Payment for Work completed through periodic progress payments or otherwise shall not operate to waive County's right to require full compliance with Contract Documents and shall in no way be deemed as acceptance of the Work paid therefore. Contractor's obligation to complete the Work in accordance with Contract Documents shall be absolute, unless County agrees otherwise in writing. Contractor shall immediately correct defective Work upon Contractor's knowledge of the defective Work, regardless of County's issuance of a correction notice or otherwise identifying the defective Work.

9.6 Samples And Tests Of Materials And Work

9.6.A. Contractor shall furnish, in such quantities and sizes as may be required for proper examination and tests, Samples or test specimens of all materials to be used or offered for use in connection with Work. Contractor shall prepare Samples or test specimens at its expense and furnish them to County. Contractor shall submit all Samples in ample time to enable County to make any necessary tests, examinations, or analyses before the time it is desired to incorporate the material into the Work.

9.7 Proof Of Compliance Of Contract Provisions

9.7.A. In order that County may determine whether Contractor has complied or is complying with requirements of Contract Documents not readily enforceable through inspection and tests of Work and materials, Contractor shall at any time, when requested, submit to County properly authenticated documents or other satisfactory proofs of compliance with all applicable requirements.

9.8 Acceptance

9.8.A. Inspection by County or its authorized agents or representatives, any order or certificate for the payment of money, any payment, acceptance of the whole or any part of Work by County, any extension of time, any verbal statements on behalf of County or its authorized agents or representatives shall not operate as a waiver or modification of any provision of the Contract Documents, or of any power reserved to County herein or therein or any right to damages provided in the Contract Documents. Any waiver of any breach of the Contract Documents shall not be held to be a waiver of any other subsequent breach.

10 CONTRACTOR'S ORGANIZATION AND EQUIPMENT

10.1 Contractor's Legal Address

10.1.A. Address and facsimile number given in Contractor's Bid are hereby designated as Contractor's legal address and facsimile number. Contractor may change its legal address and facsimile number by notice in writing, delivered to County, which in conspicuous language advises County of a change in legal address or facsimile number, and which County accepts in writing. Delivery of any drawings, notice, letter or other communication to Contractor's legal address or depositing in any post office

or post office box regularly maintained by the United States Postal Service, in a wrapper with postage affixed, directed to Contractor at legal address shall be deemed legal and sufficient service thereof upon Contractor. Facsimile to Contractor's designated facsimile number of any letter, memorandum, or other communication on standard or legal sized paper, with proof of facsimile transmission, shall be deemed legal and sufficient service thereof upon Contractor.

10.2 Contractor's Office At The Work Site

10.2.A. Contractor shall maintain an office at the Site, which office shall be headquarters of a Contractor representative authorized to transmit to and receive from County, communications, instructions or Drawings. Communications, instructions, or Drawings given to Contractor's representative or delivered at the Site office in representative's absence shall be deemed to have been given to Contractor.

10.3 Contractor's Superintendents Or Forepersons

10.3.A. Contractor shall at all times while Work is being performed at site, be represented on Site by a competent resident Superintendent authorized and competent to receive and carry out any instructions that County may give, and shall be liable for faithful observance of instructions delivered to Contractor. Said Superintendent shall not be replaced without County's express written consent. The Superintendent shall be Contractor's representative at the Site and shall have complete authority to act on behalf of Contractor. All communications to and from the Superintendent shall be as binding as if given to or by Contractor. Communications, instructions, or Drawings given to Contractor's representative shall be deemed to have been given to Contractor.

10.3.B. In the event that the designated Superintendent is unable to be present at the site, Contractor shall designate a substitute Superintendent, subject to County's approval, and shall obtain County's consent as to time and duration of any such substitution.

10.4 Proficiency In English

10.4.A. Supervisors, security guards, safety personnel and employees who have unescorted access to the Site shall possess proficiency in the English language in order to understand, receive and carry out oral and written communications or instructions relating to their job functions, including safety and security requirements.

10.5 Contractor's And Subcontractors' Employees

10.5.A. Contractor shall employ, and shall permit its Subcontractors to employ, only competent and skillful personnel to do Work. If County notifies Contractor that any of its employees, or any of its Subcontractors' employees on Work is incompetent, unfaithful, disorderly or profane, or fails to observe customary standards of conduct or refuses to carry out any provision of the Contract Documents, or uses harassing, threatening or abusive language at the site to any person representing County or to any member of the public, or violates sanitary rules, or is otherwise unsatisfactory, and if County requests that such person be discharged from Work, then Contractor or its Subcontractor shall immediately discharge such person from Work and the discharged person shall not be re-employed on the Work except with consent of County.

10.6 Contractor To List Trades Working

10.6.A. Contractor shall list the trades working on the Site and their scheduled activities on a daily basis, and provide a copy of that list to County.

10.7 Contractor's Use Of The Site

10.7.A. Contractor shall not make any arrangements with any person to permit occupancy or use of any land, structure or building within the limits of the Work, for any purpose whatsoever, either with or without compensation, in conflict with any agreement between County and any owner, former owner or tenant of such land, structure or buildings. Contractor may not occupy County-owned property outside the limit of the Work as indicated on the Drawings unless it obtains prior approval from County.

11 PROSECUTION AND PROGRESS OF THE WORK

11.1 Schedules And Examinations Of Contract Documents

- 11.1.A. Contractor shall submit schedules, reports, and submittals in the appropriate quantity and within the required time, arrange conferences and meetings and proceed with the Work in accordance with Contract Documents, including Sections 013150 (Project Meetings), 013200 (Construction Progress Documentation), and 013300 (Submittal Procedures).
- 11.1.B. Contractor shall submit to County for review and discussion:
- 11.1.B.1. At the Preconstruction Conference described in Section 013150 (Project Meetings), Progress Schedules and Reports as required by Sections 013200 (Construction Progress Documentation) and 013300 (Submittal Procedures). Contractor shall utilize Progress Schedule in planning, scheduling, coordinating, performing and controlling Work (including all activities of Subcontractors, assigned contractors, equipment vendors and suppliers). Contractor shall update Progress Schedule on a monthly basis to depict accurately the actual progress of Work and for evaluating and preparing Contractor's monthly progress payments. Contractor's failure to submit and maintain an acceptable Progress Schedule may, in County's discretion, and without limiting the materiality of Contractor's other obligations under the Contract Documents, constitute grounds to declare Contractor in material breach of the Contract Documents.
- 11.1.B.2. Seven (7) Days after Commencement Date, but no later than the Preconstruction Conference (whichever is earlier), a preliminary Schedule of Values conforming to Section 012000 (Price and Payment Procedures) paragraph 1.6.C. See Section 012000 (Price and Payment Procedures) for further requirements regarding the Schedule of Values.
- 11.1.C. Unless otherwise provided in the Contract Documents, County will review for acceptability the schedules submitted in accordance with paragraph 11.1.B of this Document 007200. Contractor shall make corrections and adjustments to complete and resubmit the schedules and shall secure County's written acceptance prior to submitting first payment request. Schedules shall be updated and completed as required by Sections 012000 (Price and Payment Procedures), 013200 (Construction Progress Documentation) and 013300 (Submittal Procedures). No progress or mobilization payment shall be due or owing to Contractor until the schedules are submitted to and acceptable to County as meeting the requirements of the Contract Documents, including Sections 012000 (Price and Payment Procedures), 013200 (Construction Progress Documentation) and 013300 (Submittal Procedures). County's acceptance of Contractor's schedules will not create any duty of care or impose on County any responsibility for the sequencing, scheduling or progress of Work nor will it interfere with or relieve Contractor from Contractor's full responsibility therefore.

11.2 Commencement of Work Notification

- 11.2.A. Before commencing any portion of Work, Contractor shall inform County in writing as to time and place at which Contractor wishes to commence Work, and nature of Work to be done, in order that proper provision for inspection of Work may occur, and to assure measurements necessary for record and payment. Information shall be given to County in a reasonable time in advance of time at which Contractor proposes to begin Work, so that County may complete necessary preliminary work without inconvenience or delay to Contractor.

11.3 Submittals

- 11.3.A. Contractor shall submit Submittals to County (or Architect if County so designates) for review in strict accordance with Section 013300 (Submittal Procedures). Submission of a Submittal shall constitute Contractor's representation that all requirements of Section 013300 (Submittal Procedures) have been complied with. All Submittals will be identified as County may require and in the number of copies

specified in Section 013300 (Submittal Procedures).

- 11.3.B. Contractor shall not perform Work that requires submission of a Submittal prior to submission and favorable review of the Submittal. Where a Submittal is required by Contract Documents or the final Schedule of Submittals (if required) accepted by County, any related Work performed prior to County's approval of the pertinent Submittal shall be at the sole expense, responsibility, and risk of Contractor.

11.4 Contractor To Supply Sufficient Workers And Materials

- 11.4.A. Unless otherwise required by County under the terms of Contract Documents, Contractor shall at all times keep on the Site materials and employ qualified workers sufficient to prosecute Work at a rate and in a sequence and manner necessary to complete Work within the Contract Time. This obligation shall remain in full force and effect notwithstanding disputes or claims of any type.
- 11.4.B. At any time during progress of Work should Contractor directly or indirectly (through Subcontractors) refuse, neglect, or be unable to supply sufficient materials or employ qualified workers to prosecute the Work as required, then County may issue a written notice to Contractor, requiring Contractor to accelerate the Work and/or furnish additional qualified workers or materials as County may consider necessary, at no cost to County. If Contractor does not comply with the notice within five (5) Days of date of service thereof, County shall have the right (but not a duty) to provide materials and qualified workers to finish the Work or any affected portion of Work, as County may elect. County may, at its discretion, exclude Contractor from the Site, or portions of the Site or separate Work elements during the time period that County exercises this right. County will deduct from moneys due or which may thereafter become due under the Contract Documents, the sums necessary to meet expenses thereby incurred and paid to persons supplying materials and doing Work. County will deduct from funds or appropriations set aside for purposes of Contract Documents the amount of such payments and charge them to Contractor as if paid to Contractor. Contractor shall remain liable for resulting delay, including liquidated damages and indemnification of County from claims of others.
- 11.4.C. Exercise by County of the rights conferred upon County in paragraph 11.4.B of this Document 007200, is entirely discretionary on the part of County. County shall have no duty or obligation to exercise the rights referred to in paragraph 11.4.B of this Document 007200 and its failure to exercise such rights shall not be deemed an approval of existing Work progress or a waiver or limitation of County's right to exercise such rights in other concurrent or future similar circumstances. The rights conferred upon County under paragraph 11.4.B of this Document 007200 are cumulative to County's other rights under any provision of the Contract Documents.
- 11.4.D. The County may, if it deems necessary for reasons other than those described in Paragraph 10.6.B, direct Contractor to accelerate the Work by increasing crew sizes, working overtime (as permitted by law) and/or performing shift work. If directed to perform overtime and/or shift work, Contractor will work said overtime and/or shift work, and the County shall pay Contractor solely for the additional premium wages paid, plus taxes imposed by law on such additional wages. Unless otherwise directed by the County, accelerated work shall be performed utilizing the most cost-effective available method. For example, the County shall not be responsible to pay the premium for overtime work if the same work could have been performed on second shift utilizing a lower premium.

11.5 Contractor's Project Data

- 11.5.A. Contractor shall maintain full and correct information as to the number of workers employed in connection with each subdivision of Work, the classification and rate of pay of each worker in form of certified payrolls, the cost to Contractor of each class of materials, tools and appliances used by Contractor in Work, and the amount of each class of materials used in each subdivision of Work. Contractor shall provide County with monthly summaries of this information. If Contractor maintains or is capable of generating summaries or reports comparing actual Project costs with Bid estimates

or budgets, Contractor shall provide County with a copy of such report upon County's request and whenever it is generated.

- 11.5.B. Contractor shall maintain daily job reports recording all significant activity on the job, including the number of workers on Site, Work activities, problems encountered and delays. Contractor shall provide County with copies for each Day Contractor works on the Project, to be delivered to County either the same Day or the following morning before starting Work at the Site. Contractor shall take monthly progress photographs of all areas of the Work. Contractor shall maintain copies of all correspondence with Subcontractors and records of meetings with Subcontractors.
- 11.5.C. County shall have the right to audit and copy Contractor's books and records of any type, nature or description relating to the Project (including but not limited to financial records reflecting in any way costs claimed on the Project), and to inspect the Site, including Contractor's trailer, or other job Site office, and this requirement shall be contained in the subcontracts of Subcontractors working on Site. By way of example, County shall have the right to inspect and obtain copies of all Contract Documents, planning and design documents, Bid proposal and negotiation documents (subject to Document 006700 [Escrow Bid Documents] if required by the Contract Documents), cost records and job cost variance reports, design modification proposals, value engineering or other cost reduction proposals, revisions made to the original design, job Progress Reports, photographs, and as-built drawings maintained by Contractor. County and any other applicable governmental entity shall have the right to inspect all information and documents maintained under this paragraph 11.5 at any time during the Project and for a period of five years following Substantial Completion. This right of inspection shall not relieve Contractor of its duties and obligations under the Contract Documents. This right of inspection shall be specifically enforceable in a court of law, either independently or in conjunction with enforcement of any other rights in the Contract Documents.
- 11.5.D. Contractor shall maintain in a safe place at the Site one record copy of all Drawings, Specifications, Addenda, Contract Modifications, Change Orders, Construction Change Directives, Force Account orders, and written interpretations and clarifications in good order and annotated to show all changes made during construction. These Project Record Documents, together with all approved Samples and a counterpart of all approved Shop Drawings, shall be maintained and available to County for reference. Upon completion of the Work, Contractor shall deliver to County, the Project Record Documents.

12 CLAIMS BY CONTRACTOR/NON-JUDICIAL SETTLEMENT PROCEDURE

12.1 Scope

- 12.1.A. The claim notice and documentation procedure described in this Article 12 applies to all claims and disputes arising under the Contract Documents, including without limitation any claim or dispute by any Subcontractor or material supplier, and any claims arising under tort law as well as contract law. All Subcontractor and supplier claims of any type shall be brought only through Contractor as provided in this Article 12. Under no circumstances shall any Subcontractor or supplier make any direct claim against County.
- 12.1.B. "Claim" means a written demand or written assertion by Contractor seeking, as a matter of right, the payment of money, the adjustment or interpretation of Contract Documents terms, or other relief arising under or relating to Contract Documents. In order to qualify as a "claim," the written demand must state that it is a claim submitted under this Article 12. A voucher, invoice, proposed change, Application for Payment, cost proposal, RFI, change order request, or other routine or authorized form of request for payment is not a claim under the Contract Documents. If such request is disputed as to liability or amount, then the disputed portion of the submission may be converted to a claim under the Contract Documents by submitting a separate notice and claim in compliance with claim submission requirements herein.
- 12.1.C. The provisions of this Article 12 constitute a non-judicial claim settlement procedure, and also step one of a two step claim presentment procedure by agreement under

Section 930.2 of the California Government Code. Specifically, step one is compliance with this contract claims procedure and filing/administering timely contract claims in accordance with the Contract Documents. Step two is filing a timely Government Code Section 910 claim in accordance with the California Government Code. Any Government Code Section 910 claims shall be presented in accordance with the Government Code and shall affirmatively indicate Contractor's prior compliance with the claims procedure herein and previous dispositions under this Article.

12.1.D. The provisions of this Article 12 shall survive termination, breach or completion of the Contract Documents. Contractor shall bear all costs incurred in the preparation and submission of a claim.

12.2 Procedure

12.2.A. Disputed Work. Should any clarification, determination, action or inaction by County or Architect/Engineer, Work, third party, or any other event whatsoever, in the opinion of Contractor, exceed the requirements of or not comply with Contract Documents in any way, or otherwise result in Contractor seeking additional compensation in time or money or damages for any reason (collectively "Disputed Work"), then Contractor shall so notify County. Contractor and County shall make good faith attempts to resolve informally any and all such issues, claims and/or disputes.

12.2.B. Duty to Work During Disputes. Notwithstanding any dispute or Disputed Work, Contractor shall continue to prosecute the Work and the Disputed Work in accordance with the determinations of County. Contractor's sole remedy for Disputed Work is to pursue the remedies in this Article 12 and follow the determinations of County.

12.2.C. Timely Notice of Disputed Work Required. Before commencing any Disputed Work, or within ten (10) Days after Contractor's first knowledge of the Disputed Work, whichever is earlier, Contractor shall file a written notice and preliminary cost proposal for the Disputed Work with County stating clearly and in detail its objection and reasons for contending the Disputed Work is outside or in breach of the requirements of Contract Documents. The written notice must identify the subcontractors, vendors, suppliers effected, if any, sufficient for County to visit the site to inspect the work and/or conduct a telephonic interview of the persons involved, and/or to photograph the work in question; and Contractor is encouraged to supply digital photographs by email if possible. The preliminary cost proposal must provide a good faith preliminary estimate of the labor (workers, crews), equipment and/or materials involved, and a corresponding good faith preliminary estimate of cost. If a written notice and preliminary cost proposal for Disputed Work is not issued within this time period, or if Contractor proceeds with the Disputed Work without first having given the notice of the Disputed Work, Contractor shall waive its rights to further claim on the specific issue.

12.2.D. Timely Notice of Potential Claims Required. County will review Contractor's timely notice and preliminary cost proposal for Disputed Work and provide a decision. If, after receiving the decision, Contractor disagrees with it or still considers the Work required of it to be outside of the requirements of Contract Documents, then Contractor shall so notify County, in writing, within ten (10) Days after receiving the decision, by submitting a notice of potential claim, stating that a formal claim will be issued. (If County should fail to provide a decision on a notice and preliminary cost proposal within thirty (30) days, then Contractor shall submit a notice of potential claim within ten days following the thirtieth (30th) day, i.e., or by the 40th day following the notice and preliminary cost proposal.) Contractor shall continue to prosecute the Disputed Work to completion.

12.2.E. Quarterly Claims Required. At the end of each calendar year quarter (March 31, June 30, September 30 and December 31) of each year, for each and every notice of potential claim that Contractor may have submitted in that quarter, Contractor shall submit a formal claim in the form specified herein. Contractor may file a single consolidated claim each quarter, or may file separate claims each quarter, as

Contractor sees fit, provided Contractor complies with the requirements below. (Contractor may defer until the next reporting period the filing of a formal claim for any notices of potential claim timely issued within the last 15 days of the prior quarter.) The formal claim(s) shall include all arguments, justification, cost or estimates, schedule analysis, and detailed documentation supporting Contractor's position, for each notice of potential claim that Contractor intends to pursue as a formal claim (further described below).

12.2.F. Claim Updates Required. If Disputed Work persists longer than a single calendar quarter, then Contractor shall, every quarter until the Disputed Work ceases, submit to County a document titled "Claim Update" that shall update and quantify all elements of the claim as completely as possible. Contractor's failure to submit a Claim Update or to quantify costs every quarter shall result in waiver of the claim for that period. Claims or Claim Updates stating that damages, total damages (direct and indirect), schedule impact and/or any time extension will be determined at a later date shall not comply with this subparagraph and shall result in Contractor waiving its claim(s). Contractor shall also maintain a continuing "claims log" that shall list all outstanding claims and their value, and provide such log to County quarterly.

12.2.G. Claim Negotiations required. Upon receipt of a demand in writing sent by registered mail or certified mail, return receipt requested, County will schedule a meet and confer conference within 30 days for settlement of the dispute. Within 10 business days following the conclusion of the meet and confer conference, if the claim or any portion of the claim remains in dispute, County will provide Contractor with a written statement identifying the portion of the claim that remains in dispute and the portion that is undisputed. Any payment due on an undisputed portion of the claim will be tendered within 60 days after County issues its written statement. Any disputed portion of the claim, as identified by Contractor in writing, shall be submitted to nonbinding mediation, with County and Contractor sharing the associated costs equally. County and Contractor shall mutually agree to a mediator within 10 business days after the disputed portion of the claim has been identified in writing. If the parties cannot agree upon a mediator, each party shall select a mediator and those mediators shall select a qualified neutral third party to mediate with regard to the disputed portion of the claim. Each party shall bear the fees and costs charged by its respective mediator in connection with the selection of the neutral mediator. If mediation is unsuccessful, the parts of the claim remaining in dispute shall be subject to the remaining procedures required by this Article 12.

At the time any disputed claim or portion of a claim is submitted to nonbinding mediation, all other claims and portions of claims that remain in dispute shall also be submitted for the same mediation, provided that each has been discussed at a meet and confer conference and has not already been submitted to mediation.

Contractor and County may mutually agree upon a written waiver of mediation, claims resolution protocols, neutral facilitators or mediators, or other alternative dispute resolution procedures, as appropriate and consistent with the Public Contract Code, including Sections 9204 and 20104 *et seq.*

12.2.H. If a claim submitted in accordance with this Article 12 totals less than \$375,000, then claims resolution shall proceed in a manner consistent with Public Contract Code Sections 9204 and 20104 *et seq.*

12.3 Administration During & After Claim Submission

12.3.A. Owner may render a final determination based on the Claim or may, in its discretion, conduct an administrative hearing on Contractor's claim, in which case Contractor shall appear, participate, answer questions and inquiries, and present any further evidence or analysis requested by Owner prior to rendering a final determination. Should Owner take no action on the Claim within 45 Days of submission, or such longer period as may be allowed pursuant to Section 9204 of the Public Contract Code, it shall be deemed denied. Consistent with Public Contract Code section 9204,

if Owner takes any action on the Claim, it will provide Contractor a written statement identifying what portion of the Claim is disputed and what portion is undisputed. Owner shall tender any payment due to Contractor on any undisputed portion of a Claim within 60 Days after Owner issues its written statement.

- 12.3.B. If Contractor disputes Owner's written response, or if Owner fails to respond to a Claim tendered pursuant to this Section 00700 within the time prescribed, Contractor may demand in writing an informal conference to meet and confer for settlement of the issues in dispute. Upon receipt of a demand in writing sent by registered mail or certified mail, return receipt requested, Owner will schedule a meet and confer conference within 30 days for settlement of the dispute. Within 10 business days following the conclusion of the meet and confer conference, if the claim or any portion of the claim remains in dispute, Owner will provide Contractor with a written statement identifying the portion of the Claim that remains in dispute and the portion that is undisputed. Any payment due on an undisputed portion of the claim will be tendered within 60 days after Owner issues its written statement. Any disputed portion of the Claim, as identified by Contractor in writing, shall be submitted to nonbinding mediation, with the Owner and the Contractor sharing the associated costs equally. The Owner and Contractor shall mutually agree to a mediator within 10 business days after the disputed portion of the Claim has been identified in writing. If the parties cannot agree upon a mediator, each party shall select a mediator and those mediators shall select a qualified neutral third party to mediate with regard to the disputed portion of the Claim. Each party shall bear the fees and costs charged by its respective mediator in connection with the selection of the neutral mediator. If mediation is unsuccessful, the parts of the Claim remaining in dispute shall be subject to the remaining procedures of this Article 12
- 12.3.C. Notwithstanding and pending the resolution of any claim or dispute, Contractor shall diligently prosecute the disputed work to final completion in accordance with Owner's determination
- 12.3.D. After their submission, claims less than \$375,000 shall also be subject to the Local Agency Disputes Act (Public Contract Code §§ 20104 et seq.), which provides further requirements to meet and confer, mediate and arbitrate before proceeding with a Government Code Claim in accordance with the procedures specified in this Article 12

12.4 Mediation

- 12.4.A. If Contractor's claims submitted in accordance with this Article 12 at Project completion total less than \$375,000, then claims resolution shall first proceed in the manner prescribed by Article 1.5, Chapter 1, Part 3 of Division 2 of the California Public Contract Code, found in Section 01410 (Regulatory Requirements).
- 12.4.B. If Contractor's claims submitted in accordance with this Article 12 at Project completion exceed \$375,000, then, as a condition precedent to litigation (or if otherwise permitted by the Contract Documents, arbitration) thereon, such claims must first be mediated. Mediation shall be non-binding and utilize the services of a mediator mutually acceptable to the parties and, if the parties cannot agree, a mediator selected by the American Arbitration Association from its panel of approved mediators trained in construction industry mediation, having a minimum of twenty (20) years experience in the construction industry. All statutes of limitation shall be tolled from the date of the demand for mediation until a date two weeks following the mediation's conclusion. All unresolved Contractor claims shall be submitted to the same mediator. The cost of mediation shall be equally shared.

12.5 Subcontractor Claims

- 12.5.A. Contractor shall present as its claims all Subcontractor, sub-Subcontractor and supplier claims of any type, and prove them under the terms of the Contract Documents. County shall not be directly liable to any Subcontractor, any supplier, or any other person or organization, or to any surety for or employee or agent of any of

them, for damages or extra costs of any type arising out of or resulting from the Project.

12.6 Waiver

- 12.6.A. If Contractor fails to comply with this Article 12 as to any claim, then Contractor shall waive its rights to such claim.
- 12.6.B. All claim(s), Disputed Work items or issue(s) not raised in a timely notice, timely notice of potential claim and then timely claim submitted under this Article 12, may not be asserted in any subsequent Government Code section 910 claim, litigation or legal action.
- 12.6.C. Contractor may request an extension of time to comply with the claims procedure herein, but must do so in advance of time periods expiring and County must give its approval in writing (which approval may be withheld in County discretion.) As to any other feature of the claim procedure herein (and its claims waiver feature), it may not be waived or altered absent a written change order signed by both parties and approved as to form by their legal counsel.
- 12.6.D. County shall not be deemed to waive or alter any provision under this Article 12, if at County's sole discretion, a claim is administered in a manner not in accord with this Article 12.

13 LEGAL AND MISCELLANEOUS

13.1 Laws And Regulations

- 13.1.A. Contractor shall keep fully informed of and shall comply with all laws, ordinances, regulations and orders of any properly constituted authority affecting the Contract Documents, Work and persons connected with Work, and shall protect and indemnify County and its officers, employees, consultants and agents against any claim or liability, including attorney's fees, arising from or based on violation of law, ordinance, regulation or order, whether by Contractor or by Subcontractors, employees or agents. Authorized persons may at any time enter upon any part of Work to ascertain compliance of all applicable laws, ordinances, regulations and orders.
- 13.1.B. Whenever Drawings and Specifications require higher standards than are required by any applicable law, ordinance, regulation or order, Drawings and Specifications shall govern. Whenever Drawings and Specifications require something that will violate such laws, ordinances, regulations or orders, then such laws, ordinances, regulations or orders shall govern.
- 13.1.C. Contractor shall comply with applicable portions of Title 8 (Industrial Relations), Title 19 (Public Safety), Title 22 (Social Security, Division of Health) and Title 24 (California Building Standards Code), California Code of Regulations (Uniform Building Code) (most recent edition), Public Contract Code. Whenever Contract Documents require larger sizes or higher standards than are required by any applicable law, ordinance, regulation or order, Contract Documents shall govern. Whenever Contract Documents require something that will violate such laws, ordinances, regulations or orders, then such laws, ordinances, regulations or orders shall govern.

13.2 Permits And Taxes

- 13.2.A. County will pay applicable building permits, school, sanitation and water demand fees, except as otherwise provided in Section 011000 (Summary). Unless otherwise noted in Section 011000 (Summary), Contractor shall procure all permits and licenses applicable to the Work (including environmental matters to the extent applicable); pay all charges and fees, including fees for street opening permits; comply with, implement and acknowledge effectiveness of all permits; initiate and cooperate in securing all required notifications or approvals therefore; and give all notices necessary and incident to due and lawful prosecution of Work. Contractor shall pay all fees related to deferred submittals such as, but not limited to, fire sprinkler system, underground utilities, fuel storage tank and fire alarm system. Contractor shall pay all sales and/or use taxes levied on materials, supplies, or equipment purchased and used on or incorporated into Work, and all other taxes

properly assessed against equipment or other property used in connection with Work, without any increase in the Contract Sum. Contractor shall make necessary arrangements with proper authorities having jurisdiction over roads, streets, pipelines, navigable waterways, railroads, and other works in advance of operations, even where County may have already obtained permits for the Work.

13.3 Suspension Of Work

- 13.3.A. County may, without cause, order Contractor in writing to suspend, delay or interrupt Work in whole or in part for such period of time as County may determine. An adjustment shall be made for increases in cost of performance of Work of the Contract Documents caused by any such suspension, delay or interruption, calculated using the measures set forth in Section 012600 (Contract Modification Procedures). No adjustment shall be made to extent that:
- 13.3.B. Performance is, was or would have been so suspended, delayed or interrupted by another cause for which Contractor is responsible; or
- 13.3.C. An equitable adjustment is made or denied under any other provision of Contract Documents; or
- 13.3.D. The suspension of Work was the direct or indirect result of Contractor's failure to perform any of its obligations hereunder. Adjustments made in cost of performance may have a mutually agreed fixed or percentage fee; if the parties cannot agree, Contractor may file a claim under Article 12 of this Document 007200.

13.4 Termination Of Contract For Cause

- 13.4.A. County may declare Contractor in default of Contract Documents and County may terminate Contractor's right to proceed under the Contract Documents for cause:
 - 13.4.A.1. Should Contractor make an assignment for the benefit of creditors; admit in writing its inability to pay its debts as they become due; file a voluntary petition in bankruptcy; be adjudged as bankrupt or insolvent; be the subject of an involuntary petition in bankruptcy which is not dismissed within 60 Days; file a petition or answer seeking for itself any reorganization, arrangement, composition, readjustment, liquidation, dissolution, or similar relief under any present or future statute, law, or regulation; file any answer admitting or not contesting the material allegations of a petition filed against Contractor in any such proceeding; or seek, consent to, or acquiesce in, the appointment of any trustee, receiver, custodian or liquidator of Contractor or of all or any substantial part of its properties or if Contractor, its directors or shareholders, take action to dissolve or liquidate Contractor; or
 - 13.4.A.2. Should Contractor commit a material breach of the Contract Documents. If County declares Contractor in default due to material breach, however, County must allow Contractor an opportunity to cure such breach within 10 Days of the date of notice from County to Contractor providing notice of the default; or, if such breach is curable but not curable within such 10-Day period, within such period of time as is reasonably necessary to accomplish such cure; or
 - 13.4.A.3. Should Contractor violate or allow (by a Subcontractor or other person or entity for which Contractor is responsible) a violation of any valid law, statute, regulation, rule, ordinance, permit, license or order of any governmental agency applicable to the Project or Work and does not cure (or cause to be cured) such violation within 10 Days of the date of the notice from County to Contractor demanding such cure; or, if such violation is curable but not curable within such 10-Day period, within such period of time as is reasonably necessary to accomplish such cure.
- 13.4.B. In order for Contractor to avail itself of a time period in excess of 10 Days, pursuant to subsections 13.4.A.2 and 13.4.A.3, Contractor must provide County within the 10-Day period with a written plan acceptable to County to cure said breach or violation which includes, for example, evidence of necessary resources, Subcontractor

- commitments, schedules and recovery schedules meeting Contract Document requirements and showing a realistic and achievable plan to cure the breach or violation. Contractor must then diligently commence and continue such cure according to the written plan.
- 13.4.C. If County at any time reasonably believes that Contractor is or may be in default under the Contract Documents as provided in paragraph 13.4.A of this Document 007200, County may in its sole discretion notify Contractor of this fact and request written assurances from Contractor of performance of Contract Documents and a written plan from Contractor to remedy any default under the terms of Contract Documents which County may advise Contractor of in writing. Contractor shall, within 10 Days of County's request, deliver a written cure plan which meets the requirements of the written plan deliverable under paragraph 13.4.A.2 of this Document 007200. Failure of Contractor to provide such written assurances of performance and the required written plan, within 10 Days of request, will constitute a material breach of Contract Documents sufficient to justify termination for cause.
- 13.4.D. In event of termination for cause, County will immediately serve written notice thereof upon Surety and Contractor. Surety shall have the rights and obligations set forth in Document 006113.13 (Performance Bond). Subject to the Surety's rights under the Performance Bond (which rights are waived upon a default thereunder), County may take over the Work and prosecute it to completion by contract or by any other methods it may deem advisable.
- 13.4.E. In the event of termination by County as provided in paragraph 13.4.A of this Document 007200 for cause:
- 13.4.E.1. County will compensate Contractor for the value of the Work delivered to County upon termination as determined in accordance with the Contract Documents, subject to all rights of offset and back charges, and provided that Contractor provides County with updated as-builts and Project Record Documents showing the Work performed up to the date of termination. However, County will not compensate Contractor for its costs in terminating the Work or any cancellation charges owed to third parties.
- 13.4.E.2. Contractor shall deliver to County possession of the Work in its then condition including, but not limited to, all designs, engineering, Project records, Project Record Documents, cost data of all types, Drawings and Specifications and contracts with vendors and Subcontractors, all other documentation associated with the Project, and all construction supplies and aids dedicated solely to performing the Work which, in the normal course of construction, would be consumed or only have salvage value at the end of the construction period. Contractor shall remain fully liable for the failure of any Work completed and materials and equipment provided through the date of such termination to comply with the provisions of the Contract Documents. The provisions of this paragraph 13.4.E shall not be interpreted to diminish any right which County may have to claim and recover damages for any breach of Contract Documents or otherwise, but rather, Contractor shall compensate County for all loss, cost, damage, expense, and/or liability suffered by County as a result of such termination and failure to comply with Contract Documents.
- 13.4.F. County's rights under paragraph 13.4.E.2 shall be specifically enforceable to the greatest extent permitted by law. County shall, to the extent applicable, have all other rights and remedies set forth in any Contract Document.
- 13.4.G. County may terminate portions or parts of the Work for cause, provided these portions or parts (i) have separate geographic areas from parts or portions of the Work not terminated or (ii) are limited to the Work of one or more specific trades or Subcontractors. In such case, Contractor shall cooperate with other contractors as required under Article 6 of this Document 007200.

13.4.H. In the event a termination for cause is determined to have been made wrongfully or without cause, then the termination shall be treated as a termination for convenience, and Contractor shall have no greater rights than it would have had following a termination for convenience. Any Contractor claim arising out of a termination for cause shall be made in accordance with Article 12 of this document and calculated in accordance with the provisions of the Contract Documents on Change Orders and claims. No other loss cost, damage, expense or liability may be claimed, requested or recovered by Contractor.

13.5 Termination Of Contract For Convenience

13.5.A. County may terminate performance of the Work under the Contract Documents in accordance with this clause in whole, or from time to time in part, whenever County shall determine that termination is in County's best interest. Termination shall be effected by County delivering to Contractor notice of termination specifying the extent to which performance of the Work under the Contract Documents is terminated and the effective date of the termination.

13.5.B. After receiving a notice of termination under paragraph 13.5.A of this Document 007200, and except as otherwise directed by County, Contractor shall:

13.5.B.1. Stop Work under the Contract Documents on date and to extent specified in notice of termination;

13.5.B.2. Place no further orders or subcontracts for materials, services, or facilities except as necessary to complete portion of Work under the Contract Documents which is not terminated;

13.5.B.3. Terminate all orders and subcontracts to extent that they relate to performance of Work terminated by the notice of termination;

13.5.B.4. Assign to County in manner, at times, and to extent directed by County, all right, title, and interest of Contractor under orders and subcontracts so terminated. County shall have the right, in its sole discretion, to settle or pay any or all claims arising out of termination of orders and subcontracts;

13.5.B.5. Settle all outstanding liabilities and all claims arising out of such termination of orders and subcontracts, with approval or ratification of County to extent County may require. County's approval or ratification shall be final for purposes of this paragraph 13.5;

13.5.B.6. Transfer title to County, and deliver in the manner, at the times, and to the extent, if any, directed by County, all fabricated or unfabricated parts, Work in process, completed Work, supplies, and all other material produced as part of, or acquired in connection with performance of, Work terminated by the notice of termination, and completed or partially completed drawings, drawings, specifications, information, and other property which, if the Project had been completed, would have been required to be furnished to County;

13.5.B.7. Use its best efforts to sell, in manner, at times, to extent, and at price or prices that County directs or authorizes, any property of types referred to in paragraph 13.5.B.6 of this Document 007200, but Contractor shall not be required to extend credit to any purchaser, and may acquire any such property under conditions prescribed and at price or prices approved by County. Proceeds of transfer or disposition shall be applied to reduce payments to be made by County to Contractor under the Contract Documents or shall otherwise be credited to the price or cost of Work covered by Contract Documents or paid in such other manner as County may direct;

13.5.B.8. Complete performance of the part of the Work which was not terminated by the notice of termination; and

13.5.B.9. Take such action as may be necessary, or as County may direct, to protect and preserve all property related to Contract Documents which is in Contractor's possession and in which County has or may acquire

interest.

13.5.C. After receipt of a notice of termination under paragraph 13.5.A of this Document 007200, Contractor shall submit to County its termination claim, in form and with all certifications required by Article 12 of this Document 007200. Contractor's termination claim shall be submitted promptly, but in no event later than 6 months from effective date of the termination. Contractor and County may agree upon the whole or part of the amount or amounts to be paid to Contractor because of a total or partial termination of Work under this paragraph 13.5. If Contractor and County fail to agree on the whole amount to be paid to Contractor because of the termination of the Work under this paragraph 13.5, County's total liability to Contractor by reason of the termination shall be the total (without duplication of any items) of:

13.5.C.1. The reasonable cost to Contractor, without profit, for all Work performed prior to the effective date of the termination, including Work done to secure the Project for termination. Reasonable cost may not exceed the applicable percentage completion values derived from the Progress Schedule and the schedule of values. Deductions shall be made for cost of materials to be retained by Contractor, cost of Work defectively performed, amounts realized by sale of materials, and for other appropriate credits against cost of Work. Reasonable cost will include reasonable allowance for Project overhead and general administrative overhead not to exceed a total of ten percent of direct costs of such Work. When, in County's opinion, the cost of any item of Work is excessively high due to costs incurred to remedy or replace Defective or rejected Work, reasonable cost to be allowed will be the estimated reasonable cost of performing the Work in compliance with requirements of Contract Documents and excessive actual cost shall be disallowed.

13.5.C.2. A reasonable allowance for profit on cost of Work performed as determined under paragraph 13.5.C.1 of this Document 007200, provided that Contractor establishes to County's satisfaction that Contractor would have made a profit had the Project been completed, and provided further that the profit allowed shall not exceed 5 percent of cost.

13.5.C.3. Reasonable costs to Contractor of handling material returned to vendors, delivered to County or otherwise disposed of as directed by County.

13.5.C.4. A reasonable allowance for Contractor's internal administrative costs in preparing termination claim.

13.5.C.5. Except as provided in this paragraph 13.5.C of this Document 007200, County shall not be liable for costs incurred by Contractor or Subcontractors after receipt of a notice of termination. Such non-recoverable costs include, but are not limited to, anticipated profits on Work not performed as of the date of termination, post-termination employee salaries, post-termination general administrative expenses, post-termination overhead or unabsorbed overhead, costs of preparing and submitting Contractor's Bid, attorney's fees of any type, and all costs relating to prosecution of claim or lawsuit.

13.5.D. County shall have no obligation to pay Contractor under this paragraph 13.5 unless and until Contractor provides County with updated and acceptable as-builts and Project Record Documents for Work completed prior to termination.

13.5.E. In arriving at the amount due Contractor under this clause, there shall be deducted:

13.5.E.1. All unliquidated advances or other payments on account previously made to Contractor which are applicable to the terminated portion of Contract Documents;

13.5.E.2. Any claim which County may have against Contractor in connection with Contract Documents; and

13.5.E.3. The agreed price for, or proceeds of sale of, any materials, supplies, or other things kept by Contractor or sold under provisions of this paragraph

13.5, and not otherwise recovered by or credited to County.

13.6 Contingent Assignment Of Subcontracts

13.6.A. Contractor hereby assigns to County each Subcontract for a portion of the Work, provided that:

- 13.6.A.1. The assignment is effective only after County's termination of Contractor's right to proceed under the Contract Documents (or portion thereof relating to that Subcontract) pursuant to paragraphs 13.4 or 13.5 of this Document 007200.
- 13.6.A.2. The assignment is effective only for the Subcontracts which County expressly accepts by notifying the Subcontractor in writing;
- 13.6.A.3. The assignment is subject to the prior rights, if any, of the Surety, obligated by Document 006113.13 (Performance Bond Form) provided under the Contract Documents, where the Surety exercises its rights to complete the Contract;
- 13.6.A.4. After the effectiveness of an assignment, Contractor shall, at its sole cost and expense (except as otherwise provided in paragraphs 13.4 or 13.5 of this Document 007200), sign all instruments and take all actions reasonably requested by County to evidence and confirm the effectiveness of the assignment in County; and
- 13.6.A.5. Nothing in this paragraph 13.6 shall modify or limit any of Contractor's obligations to County arising from acts or omissions occurring before the effectiveness of any Subcontract assignment, including but not limited to all defense, indemnity and hold-harmless obligations arising from or related to the assigned Subcontract.

13.7 Remedies and Contract Integration

- 13.7.A. Subject to Contract Documents provisions regarding Contractor claims, claim review, and claim resolution, and subject to the limitations therein, the exclusive jurisdiction and venue for resolving all claims, counter-claims, disputes and other matters in question between County and Contractor arising out of or relating to Contract Documents, any breach thereof or the Project shall be the applicable court of competent jurisdiction located in the State of California, County of Sonoma. All County remedies provided in the Contract Documents shall be taken and construed as cumulative and not exclusive; that is, in addition to each and every other remedy herein provided; and in all instances County shall have any and all other equitable and legal rights and remedies which it would have according to law.
- 13.7.B. The Contract Documents, any Contract Modifications, and Change Orders shall represent the entire and integrated agreement between County and Contractor regarding the subject matters hereof and thereof and shall constitute the exclusive statement of the terms of the parties' agreement. The Contract Documents, and any Contract Modifications and Change Orders, shall supersede any and all prior negotiations, representations or agreements, written or oral, express or implied, that relate in any way to the subject matter of the Contract Documents or written Modifications. County and Contractor represent and agree that, except as otherwise expressly provided in the Contract Documents, they are entering into the Contract Documents and any subsequent written Modification in sole reliance upon the information set forth or referenced in the Contract Documents or Contract Modifications and the parties are not and will not rely on any other information.
- 13.7.C. In any proceeding to enforce the Contract Documents, Contractor and County agree that the finder of fact shall receive detailed instructions on the meaning and operation of the Contract Documents, including their conditions, limitations of liability and remedies clauses, claims procedures and any other provisions impacting major defenses and theories of liability of the parties. Detailed findings of fact shall be requested, to verify Contract enforcement.
- 13.7.D. Either party's waiver of any breach or failure to enforce any of the terms, covenants, conditions or other provisions of the Contract Documents at any time shall not in any

way affect, limit, modify or waive that party's right thereafter to enforce or compel strict compliance with every term, covenant, condition or other provision hereof, any course of dealing or custom of the trade or oral representations notwithstanding.

13.8 Patents

13.8.A. Fees or claims for any patented invention, article or arrangement that may be used upon or in any manner connected with performance of the Work or any part thereof shall be included in the Bid price for doing the Work. Contractor shall defend, indemnify and hold harmless County and each of its officers, employees, consultants and agents, including, but not limited to, the Board and each County's Representative, from all damages, claims for damages, costs or expenses in law or equity, including attorney's fees, arising from or relating to any claim that any article supplied or to be supplied under the Contract Documents infringes on the patent rights, copyright, trade name, trademark, service mark, trade secret or other intellectual property right of any person or persons or that the person or entity supplying the article does not have a lawful right to sell the same. Such costs or expenses for which Contractor agrees to indemnify and hold harmless the above indemnities include but are not limited to any and all license fees, whether such fees are agreed by any indemnitee or ordered by a court or administrative body of any competent jurisdiction.

13.9 Substitution For Patented And Specified Articles

13.9.A. Except as noted specifically in Specifications, whenever in Specifications, material or process is designated by patent or proprietary name or by name of manufacturer, such designation shall be deemed to be used for purpose of facilitating description of material and process desired, and shall be deemed to be followed by the words "or Approved Equal" and Contractor may offer any substitute material or process that Contractor considers "equal" in every respect to that so designated and if material or process offered by Contractor is, in opinion of County, Equal in every respect to that so designated, its use will be approved. However, Contractor may utilize this right only by timely submitting Document 00660 (Substitution Request Form) as provided in Document 002113 (Instructions to Bidders). A substitution will be approved only if it is a true Equal item in every aspect of its design and quality, including but not limited to its dimensions, weights, service requirements, durability, functioning, impact on contiguous construction elements, overall schedule and design.

13.10 Interest Of Public Officers

No representative, officer, or employee of County, no member of the governing body of the locality in which the Project is situated, no member of the locality in which County was activated, and no other public official of such locality or localities who exercises any functions or responsibilities with respect to the Project, during the tenure of the official or for one year thereafter, shall, as principal, agent, attorney or otherwise, be directly or indirectly interested, in the Contract Documents or the proceeds thereof.

13.11 Limit Of Liability

COUNTY, AND EACH OF ITS OFFICERS, BOARD MEMBERS, EMPLOYEES, CONSULTANTS AND AGENTS INCLUDING, BUT NOT LIMITED TO, ARCHITECT AND EACH OTHER COUNTY REPRESENTATIVE, SHALL HAVE NO LIABILITY TO CONTRACTOR FOR SPECIAL, CONSEQUENTIAL, OR INCIDENTAL DAMAGES, EXCEPT TO THE LIMITED EXTENT THAT THESE CONTRACT DOCUMENTS OR APPLICABLE PUBLIC CONTRACTING STATUTES MAY SPECIFY THEIR RECOVERY.

13.12 Severability

Any provisions or portions thereof of Contract Documents that are prohibited by, unlawful, or unenforceable under any applicable law of any jurisdiction shall as to such jurisdiction be ineffective without affecting other provisions or portions thereof in the Contract Documents.

14 MODIFICATIONS OF CONTRACT DOCUMENTS

14.1 Alterations, Modifications And Force Account Work

- 14.1.A. No modification or deviation from the Drawings and Specifications will be permitted except by written Contract Modification.
- 14.1.B. County may, without notice to the sureties, make alterations, deviations, additions to, or deletions from Contract Documents; increase or decrease the quantity of any item or portion of the Work; expand, contract or otherwise change the Contract Time; delete any item or portion of the Work; and/or require extra Work. Contractor shall perform such Work under applicable provisions of the Contract Documents, unless specifically provided otherwise at the time the change is ordered. In the case of any ordered extra Work, County reserves the right to furnish all or portions of associated labor, material, and equipment, which Contractor shall accept and use without payment for costs, markup, profit, or otherwise for such County-furnished labor, materials, and equipment.
- 14.1.C. If changes ordered in design, workmanship or materials are of such a nature as to increase or decrease the cost of any part of the Work, the price fixed in the Contract Documents shall be increased or decreased as set forth in a written Change Order by the amount that Contractor and County may agree upon as a reasonable and proper allowance for the cost increase or decrease. If an agreement cannot be reached, then County will reach a determination, which shall be final, subject to Contractor's rights under Article 12 of this Document 007200. In all cases Contractor shall perform the changed Work as directed by County subject to Contractor's rights under Article 12 of this Document 007200.
- 14.1.D. A Change Order will become effective when signed by County. If County exercises its right to decide disputed issues pertaining to changed Work as set forth in Articles 12 and 14 of this Document 007200, then the resulting Change Order shall be effective when signed by County, notwithstanding that Contractor has not signed it.
- 14.1.E. Changes not affecting the Contract Time or Contract Sum of the Work, in County's discretion, may be set forth in a written RFI-Reply executed by County or Architect's Supplemental Instruction (ASI). Execution of such an RFI-Reply or ASI constitutes Contractor's agreement to make the specified change without change to the Contract Sum or the Contract Time.
- 14.1.F. Changes or deviations from Contract Documents affecting the Contract Time or Contract Sum of the Work shall not be made without the authority of an effective Change Order or Construction Change Directive as provided in Section 012600 (Contract Modification Procedures), except in cases of emergency discussed in Article 15 of this Document 007200.
- 14.1.G. Changes in the Work made pursuant to this Article 14 and extensions of Contract Time necessary by reason thereof shall not in any way release the guarantees and warranties given by Contractor pursuant to provisions of the Contract Documents, nor shall such changes in the Work relieve or release the Sureties of bonds executed pursuant to said provisions. The Sureties, in executing such bonds, shall be deemed to have expressly agreed to any such change in the Work and to any extension of time made by reason thereof.
- 14.1.H. Procedures for Modifications of Contract Documents and for calculating the cost of extra Work are given in Section 012600 (Contract Modification Procedures). Regarding delay and impact costs of any nature, Contractor may not seek delay compensation for on-Site or off-Site costs based on formulas, e.g., "Eichlay" or other formula. Rather, Contractor shall prove actual costs resulting from such delays. If Contractor requests compensation for delay to the construction, then Contractor shall prove and document actual costs plus markup per the cost categories and procedures in Section 012600 (Contract Modification Procedures) in order to request, claim or prove compensation for delay.

14.2 Time Allowances

- 14.2.A. The Contract Time may only be changed by Change Order or by Contract

Modification, and all time limits stated in the Contract Documents are of the essence of Contract Documents.

- 14.2.B. The Contract Time will be adjusted in an amount equal to the time lost or added due to:
 - 14.2.B.1. Changes in the Work ordered by County;
 - 14.2.B.2. Acts or neglect by County, Architect, any County's Representative, utility owners or other contractors performing other work, provided that Contractor has fully and completely performed its responsibilities under the Contract Documents; or
 - 14.2.B.3. Fires, floods, epidemics, abnormal weather conditions beyond the parameters otherwise described or referenced in paragraph 14.4 below, earthquakes, civil or labor disturbances, strikes or acts of God, provided damages resulting therefrom are not the result of Contractor's failure to protect the Work as required by Contract Documents.
- 14.2.C. The Contract Time shall not be extended for any cause identified in paragraph 14.2.B above, however, unless:
 - 14.2.C.1. Contractor actually has been prevented from completing any part of the Work within the Contract Time due to delay that is beyond Contractor's control and due to reasons for which Contractor is not responsible (delays attributable to and within the control of a Subcontractor, or its subcontractors, or supplier shall be deemed to be delays within the control of Contractor);
 - 14.2.C.2. A claim for delay is made as provided herein; and
 - 14.2.C.3. Contractor submits a Time Impact Evaluation as required under Section 013200 (Construction Progress Documentation) that demonstrates actual delay to critical Work activities that actually delay the progress of the Work in the amount of time requested.

14.3 Notice Of Delay

- 14.3.A. Within seven (7) Days of the beginning of any delay, Contractor shall notify County in writing, by submitting a notice of potential claim, of all anticipated delays resulting from the delay event in question. Any request for extension of time shall be accompanied by Contractor's written statement that the adjustment claimed is the entire adjustment to which the claimant is entitled as a result of the occurrence of said event, and shall include a written schedule document that demonstrates delay to the critical path using a Time Impact Evaluation as specified in Section 013200 (Construction Progress Documentation). County will determine all claims and adjustments in the Contract Time. No claim for an adjustment in the Contract Time will be valid and such claim will be waived if not submitted in accordance with the requirements of this paragraph 14.3.A.

14.4 Non-Compensable Time Extensions; Adverse Weather Parameters

- 14.4.A. Where Contractor is prevented from completing any part of the Work within the Contract Time due to delay beyond the reasonable control of Contractor and County, e.g., adverse weather conditions exceeding Contract Documents parameters, earthquakes, Acts of God and epidemics, and acts of other contractors or utilities. In such cases, an extension of Contract Time, in an amount equal to the time lost due to such delay (without compensation), shall be Contractor's sole and exclusive remedy for such delay. The adverse weather contingency for this Contract is provided in Document 00800 (Supplementary Conditions).
- 14.4.B. Delays due to abnormal or adverse weather conditions will not be allowed for weather conditions that fall within the Contract's adverse weather contingency, nor will Contractor be entitled to any extension of Contract Time for any such delays. Contractor shall be entitled to an extension of Contract Time for adverse weather only (i) if the number of workdays of adverse weather, recognize as provided in this paragraph 14.4, exceeds these parameters (ii) Contractor proves that adverse weather actually caused delays to Work that is on the critical path, and (iii) Contractor

satisfies the other requirements of this paragraph 14.4.

- 14.4.C. In order to qualify as an adverse weather day with respect to the foregoing parameters, daily rainfall must exceed 0.1 of an inch or more at the National Oceanic & Atmospheric Administration weather station identified in Document 007300 (Supplementary Conditions), and Contractor must give County written notice of its intent to claim an adverse weather day within one Day of the adverse weather day occurring. Contractor shall at all times employ all available mitigation measures to enable Work to continue.
- 14.4.D. Contractor shall include the foregoing rain parameters as in its Progress Schedule as required in Section 013200 (Construction Progress Documentation). As Work on the critical path is affected by rain, Contractor shall notify County and request that the days be moved to the affected activities. Any adverse weather days remaining shall be considered Project float.
- 14.4.E. Subject to the other requirements of this paragraph, adverse weather days shall be recognized for the actual number of days Contractor proves it was delayed by adverse weather. For example, and not by way of limitation, if rain exceeding the amount described in paragraph 14.4.C does not in fact delay Contractor's progress on the critical path, then no adverse weather days shall be recognized. Conversely, if Contractor proves that rain exceeding the amount described in paragraph 14.4.C causes delay to Contractor for a period longer than the number of rain days incurred (e.g., if it rains during grading Work), then all such days shall be recognized as adverse weather days.
- 14.4.F. Contractor shall take reasonable steps to mitigate potential weather delays, such as dewatering the Site, lime treatment, and covering Work and material that could be affected adversely by weather. Failure to do so shall be cause for County to not recognize adverse weather days, where Contractor could have avoided or mitigated the potential delay by exercising reasonable care.

14.5 Compensable Time Extensions

- 14.5.A. Contractor may receive a time extension and be compensated for delays caused directly and solely by County. Provided Contractor provides proper notice and documentation under Section 013200, such compensation may include extended field or home office overhead, field supervision, escalation charges, acceleration costs and extended subcontractor costs.
- 14.5.B. Contractor shall not be entitled to any time extension or compensation for any delays caused in whole or in part by Contractor's failure to perform its obligations under the Contract Documents, or during periods of delay concurrently caused by Contractor and either County or others.
- 14.5.C. Contractor shall not be entitled to damages for delay to the Work caused by the following reasons:
 - 14.5.C.1. County's right to sequence the Work in a manner which would avoid disruption to County's contractors and their subcontractors and County's employees, exercised as a result of Contractor's failure to perform its cooperation and coordination responsibilities required by Contract Documents; County's enforcement of any government act or regulation; or the provisions of the Contract Documents; and
 - 14.5.C.2. Extensive requests for clarifications to Contract Documents or Contract Modifications thereto, provided such clarifications or Contract Modifications are processed by County or its consultants in a reasonable time commensurate with Contract Documents requirements.

14.6 Liquidated Damages

- 14.6.A. Time is of the essence. Execution of Contract Documents by Contractor shall constitute acknowledgement by Contractor that Contractor understands, has ascertained and agrees that County will actually sustain damages in the amount fixed in the Contract Documents for each and every Day during which completion of Work required is delayed beyond expiration of time fixed for completion or extensions of

time allowed pursuant to provisions hereof. Contractor and County agree that specified measures of liquidated damages shall be presumed to be the damages actually sustained by County as defined below, and that because of the nature of the Project, it would be impracticable or extremely difficult to fix the actual damages.

- 14.6.B. Liquidated damages shall be considered not as a penalty but as agreed monetary damage sustained by County for increased Project administration expenses, including extra inspection, construction management, architectural and engineering expenses and County staffing costs related to the Project and Contract Documents because Contractor failed to perform and complete Work within time fixed for completion or extensions of time allowed pursuant to provisions hereof. Liquidated damages shall not be deemed to include within their scope additional damages or administrative costs arising from Defective Work, lost revenues, interest expenses, cost of completion of the Work, cost of substitute facilities, claims and fines of regulatory agencies, damages suffered by others or other forms of liability claimed against County as a result of delay (e.g., delay or delay-related claims of other contractors or subcontractors), and defense costs thereof. Contractor shall be fully responsible for the actual amount of any such damages it causes, in addition to the liquidated damages otherwise due County.
- 14.6.C. County may deduct from any money due or to become due to Contractor subsequent to time for completion of entire Work and extensions of time allowed pursuant to provisions hereof, a sum representing then-accrued liquidated damages. Should Contractor fall behind the approved Progress Schedule, County may deduct liquidated damages based on its estimated period of late completion. County need not wait until Final Completion to withhold liquidated damages from Contractor's progress payments. Should money due or to become due to Contractor be insufficient to cover aggregate liquidated damages due, then Contractor forthwith shall pay the remainder of the assessed liquidated damages to County.

14.7 Differing Site Conditions

- 14.7.A. If Contractor encounters underground conditions that exceed the scope of the Work, Contractor shall promptly give County written notice of the condition, and shall give such notice before the conditions are disturbed, to include: (i) material that Contractor believes may be material that is hazardous waste, as defined in Section 25117 of the Health and Safety Code, that is required to be removed to a Class I, Class II, or Class III disposal site in accordance with provisions of existing law, and is not within the scope of Work ("hazardous waste"); (ii) subsurface or latent physical conditions at the site differing from those indicated by information about the Site made available to Bidders prior to the deadline for submitting Bids, that Contractor did not and could not have known about by performing its required pre-Bid investigations; or (iii) unknown physical conditions at the Site of any unusual nature, different materially from those ordinarily encountered and generally recognized as inherent in work of the character provided for the Contract, that Contractor did not and could not have known about by performing its required pre-Bid investigations.
- 14.7.B. County shall promptly investigate the underground conditions, and if it finds that (i) the conditions do materially so differ in a manner Contractor did not anticipate and could not have anticipated, or do involve hazardous waste outside the scope of the Work, and (ii) cause a decrease or increase in Contractor's cost of, or the time required for, performance of any part of the Work, then (iii) County shall initiate a change order under the procedures described in the contract, including but not limited to, issuing either a Request for Proposal or a Construction Change Directive under the procedures described in the Contract Documents, including without limitation Section 012600 (Contract Modification Procedures).
- 14.7.C. If County determines that underground conditions at the Site do not materially so differ in a manner Contractor did not anticipate and could not have anticipated, or do not involve hazardous waste outside the scope of the Work, or do not cause a decrease or increase in Contractor's cost of, or the time required for, performance of any part of the Work, or for any other reason that that no change in terms of the

Contract Documents is justified, County will so notify Contractor in writing, stating reasons.

- 14.7.D. In the event that a dispute arises between County and Contractor whether the conditions do materially so differ, or involve hazardous waste, and cause a decrease or increase in Contractor's cost of, or the time required for, performance of any part of the Work, Contractor shall not be excused from any scheduled completion date provided for by the Contract, but shall proceed with all Work to be performed under the Contract. Contractor shall retain any and all rights provided either by the Contract or by law which pertain to the resolution of disputes and protests between contracting parties.
- 14.7.E. Contractor shall not be entitled to any adjustment in the Contract Sum or Contract Time regarding claimed hazardous waste or materials, claimed Latent or materially different Site conditions (whether above or below grade) if:
 - 14.7.E.1. Contractor knew of the existence of such conditions at the time Contractor submitted its Bid; or
 - 14.7.E.2. Contractor should have known of the existence of such conditions at the time Contractor submitted its Bid, or should have learned of such conditions and mitigated their impact, as a result of having complied with the requirements of Contract Documents, including without limitation, the investigation requirements herein at Articles 2 and 10 of Document 007200;
 - 14.7.E.3. The information or conditions claimed by Contractor to be Latent or materially different consist of information, conclusions, opinions or deductions made from underground conditions reports, of the kind that this Document 007200 precludes reliance upon; or
 - 14.7.E.4. Contractor was required to give written notice and failed to do so within the time required.
- 14.7.F. If, because of a differing site condition as defined herein, Contractor does not agree to continue with Work based on a reasonable belief that it is unsafe, or does not agree to resume Work under special conditions, County may order the disputed portion of Work deleted from the Work, or performed by others, or County may invoke its right to terminate Contractor's right to proceed under the Contract Documents in whole or in part, for convenience or for cause as the facts may warrant. If Contractor does not agree with County's determination of any adjustment in the Contract Sum or Contract Time as a result, Contractor may make a claim as provided in Article 12 of this Document 007200.

14.8 Change Orders Related to Underground Facilities

- 14.8.A. If an Underground Facility is uncovered or revealed at or contiguous to the Site which was not shown or indicated in the materials supplied by County or in information on file at USA or is not otherwise reasonably known to Contractor by performing its obligations in Articles 2 and 10 of this Document 007200, then Contractor shall, promptly after becoming aware thereof and before further disturbing conditions affected thereby (and in no event later than seven Days), and prior to performing any Work in connection therewith (except in an emergency as required by Article 15 of this Document 007200), identify the owner of such Underground Facility and give written notice to that owner and to County. During such time, Contractor shall be responsible for the safety and protection of such Underground Facility.
- 14.8.B. Contractor shall be allowed an increase in the Contract Sum or an extension of the Contract Time, or both, for Underground Facilities either not shown or inaccurately shown in the Contract Documents, the information supplied pursuant to Document 003119 (Existing Condition Information) or in information on file at USA, only where the inaccuracy was (i) material and outside of the normal experience on projects of this nature, (ii) was not reasonably inferable from existing information, and (iii) directly results in a material, justifiable and actual increase in the cost of Contractor's work. For example, if surface conditions such as pavement repairs, valve covers, or other markings, indicate the presence of an Underground Facility, or if the Underground

Facility could be determined or its cost impact mitigated by performing the obligations in Articles 2 and/or 10 of this Document 007200, then an increase in the Contract Price or an extension of the Contract Time will not be due, even if the Underground Facility was not indicated or was shown at a different place or a different elevation in the Contract Documents, in the information supplied to Contractor pursuant to Document 003119 (Existing Conditions Information), or in information on file at USA.

- 14.8.C. Main Line and Trunk Line Utilities (Government Code Section 4215). Consistent with Government Code Section 4215, as between County and Contractor, County will be responsible for the timely removal, relocation, or protection of existing main or trunk line utility facilities located on the Site only if such utilities are not identified in the Contract Documents or Document 003119 (Existing Condition Information). County will compensate for the cost of locating and repairing damage not due to Contractor's failure to exercise reasonable care, removing and relocating such main or trunk line utility facilities not indicated in the Contract Documents or Document 003119 (Existing Condition Information) with reasonable accuracy, and equipment on the Project necessarily idled during such work.

15 WORKING CONDITIONS AND PREVAILING WAGES

15.1 Use Of Site/Sanitary Rules

- 15.1.A. All portions of the Work shall be maintained at all times in neat, clean and sanitary condition. Contractor shall furnish toilets for use of Contractor's and Subcontractors' employees on the Site where needed, and their use shall be strictly enforced. All toilets shall be properly secluded from public observation, and shall be located, constructed and maintained subject to County's approval.
- 15.1.B. Contractor shall confine construction equipment, the storage of materials and equipment and the operations of workers to the Site and land areas identified in and permitted by Contract Documents and other land and areas permitted by applicable laws and regulations, rights of way, permits and easements or as designated by County, and shall not unreasonably encumber the premises with construction equipment or other materials or equipment. Contractor shall assume full responsibility for any damage to any such land or area, any improvement located thereon, or to the County or occupant thereof resulting from the performance of Work.
- 15.1.C. During the progress of the Work, Contractor shall keep the Site and the Project free from accumulations of waste materials, rubbish and other debris resulting from the Work. At the completion of the Work, Contractor shall remove all waste materials, rubbish and debris from and about the Site as well as all tools, appliances, construction equipment and machinery and surplus materials. Contractor shall leave the premises clean and ready for occupancy by County at Substantial Completion of Work. Contractor shall restore to original condition all property not designated for alteration by Contract Documents.
- 15.1.D. Contractor shall not load nor permit any part of any structure or pavement to be loaded in any manner that will endanger the structure or pavement, nor shall Contractor subject any part of Work or adjacent property to stresses or pressures that will endanger it. Contractor shall conduct all necessary existing conditions investigation regarding structural, mechanical, electrical or any other system existing, shall perform Work consistent with such existing conditions, and shall have full responsibility for insufficiencies or damage resulting from insufficiencies of existing systems, equipment or structures to accommodate performing the Work.

15.2 Protection Of Work, Persons, And Property

- 15.2.A. Contractor shall be responsible for initiating, maintaining and supervising all safety precautions and programs in connection with Work. Contractor shall comply with all safety requirements specified in any safety program established by County, or required by state, federal or local laws and ordinances. Contractor shall be responsible for all damage to Work, property or structures, and all injuries to persons, arising from the performance of Work of the Contract Documents.
- 15.2.B. Contractor shall comply with all applicable laws and regulations of any public body

having jurisdiction for safety of persons or property or to protect them from damage, injury or loss; and shall erect and maintain all necessary safeguards for such safety and protection. Contractor shall notify owners of adjacent property and of Underground Facilities and utility owners when prosecution of the Work may affect them, and shall cooperate with them in the protection, removal, relocation and replacement of their property.

- 15.2.C. Contractor shall remedy all damage, injury or loss to any property referred to in paragraph 15.2.A of this Document 007200, caused, directly or indirectly, in whole or in part, by Contractor, any Subcontractor, supplier, or any other person or organization directly or indirectly employed by any of them to perform or furnish any Work or anyone for whose acts any of them may be liable. Contractor's duties and responsibility for safety and for protection of Work shall continue until such time as all the Work is completed and Final Acceptance of the Work. County and its agents do not assume any responsibility for collecting any indemnity from any person or persons causing damage to Contractor's Work.
- 15.2.D. Contractor shall designate a qualified and experienced safety representative at the Site whose duties and responsibilities shall be the prevention of accidents and the maintaining and supervising of safety precautions and programs.
- 15.2.E. County may, at its option, retain such moneys due under the Contract Documents as County deems necessary until any and all suits or claims against Contractor for injury to persons or property shall be settled and County receives satisfactory evidence to that effect.

15.3 Responsibility For Safety And Health

- 15.3.A. Contractor shall ensure that its and each tier of Subcontractors' employees, agents and invitees comply with applicable health and safety laws while at the Site. These laws include the Occupational Safety and Health Act of 1970 and rules and regulations issued pursuant thereto, and County's safety regulations as amended from time to time. Contractor shall comply with all County directions regarding protective clothing and gear.
- 15.3.B. Contractor shall be fully responsible for the safety of its and its Subcontractors' employees, agents and invitees on the Site. Contractor shall notify County, in writing, of the existence of hazardous conditions, property or equipment at the Site that are not under Contractor's control. Contractor shall be responsible for taking all the necessary precautions against injury to persons or damage to the property of Contractor, Subcontractors or persons from recognized hazards until the responsible party corrects the hazard.
- 15.3.C. Contractor shall confine all persons acting on its or its Subcontractors' behalf to that portion of the Site where Work under the Contract Documents is to be performed, County-designated routes for ingress and egress thereto, and any other County-designated area. Except those routes for ingress and egress over which Contractor has no right of control, within such areas, Contractor shall provide safe means of access to all places at which persons may at any time have occasion to be present.

15.4 Emergencies

- 15.4.A. In emergencies affecting the safety or protection of persons or Work or property at the Site or adjacent thereto, Contractor, without special instruction or authorization from County, is obligated to act to prevent threat and damage, injury or loss, until directed otherwise by County. Contractor shall give County prompt written notice if Contractor believes that any significant changes in Work or variations from Contract Documents have been caused thereby. If County determines that a change in the Contract Documents is required because of the action taken by Contractor in response to such an emergency, a Change Order or Construction Change Directive will be issued to document the consequences of such action.

15.5 Use Of Roadways And Walkways

- 15.5.A. Contractor shall not unnecessarily interfere with use of any roadway, walkway or other facility for vehicular or pedestrian traffic. Before beginning any interference and

only with County's prior concurrence, Contractor may provide detour, traffic control, or temporary bridge for traffic to pass around or over the interference, which Contractor shall maintain in satisfactory condition as long as interference continues. Unless otherwise provided in the Contract Documents, Contractor shall bear the cost of these temporary facilities.

15.6 Nondiscrimination

15.6.A. No person or entity shall discriminate in the employment of persons upon public works because of race, religious creed, color, national origin, ancestry, physical disability, mental disability, medical condition, marital status, sexual preference, or gender of such persons, except as provided in Section 12940 of the Government Code. Every contractor for public works violating the provisions of Section 1735 of the Labor Code is subject to all the penalties imposed for a violation of Chapter 1, Part 7, Division 2 of the Labor Code.

15.7 Prevailing Wages

15.7.A. Contractor shall pay to persons performing labor in and about Work provided for in the Contract Documents an amount equal to or more than the general prevailing rate of per diem wages for (i) work of a similar character in the locality in which the Work is performed and (ii) legal holiday and overtime work in said locality. The per diem wages shall be an amount equal to or more than the stipulated rates contained in a schedule that has been ascertained and determined by the Director of the State Department of Industrial Relations and County to be the general prevailing rate of per diem wages for each craft or type of workman or mechanic needed to execute this Contract. Contractor shall also cause a copy of this determination of the prevailing rate of per diem wages to be posted at each Site, in addition to all other job site notices prescribed by regulation. Copies of the general prevailing rates of per diem wages for each craft, classification, or type of worker needed to execute the Contract, as determined by Director of the State of California Department of Industrial Relations, are on file at County's Architecture Division and are deemed included in the Bidding Documents. Upon request, County will make copies available to any interested party. Contractor shall post the applicable prevailing wage rates at the Site.

15.7.B. Contractor shall forfeit, as a penalty to County, Fifty Dollars (\$50.00) for each laborer, workman, or mechanic employed in performing labor in and about the Work provided for in the Contract Documents for each Day, or portion thereof, that such laborer, workman or mechanic is paid less than the said stipulated rates for any Work done under the Contract Documents by him or her or by any Subcontractor under him or her, in violation of Articles 1 and 2 of Chapter 1 of Part 7 of Division II of the California Labor Code. The sums and amounts which shall be forfeited pursuant to this paragraph 15.7.B and the terms of the Labor Code shall be withheld and retained from payments due to Contractor under the Contract Documents, pursuant to this Document 007200 and the Labor Code, but no sum shall be so withheld, retained or forfeited except from the final payment without a full investigation by either the State Department of Industrial Relations or by County. The Labor Commissioner pursuant to Labor Code Section 1775 shall determine the final amount of forfeiture.

15.7.C. Contractor shall insert in every subcontract or other arrangement which Contractor may make for performance of Work or labor on Work provided for in the Contract, provision that Subcontractor shall pay persons performing labor or rendering service under subcontract or other arrangement not less than the general prevailing rate of per diem wages for work of a similar character in the locality in which the Work is performed, and not less than the general prevailing rate of per diem wages for holiday and overtime work fixed in the Labor Code.

15.7.D. Contractor stipulates that it shall comply with all applicable wage and hour laws, including without limitation Labor Code 1725.5, 1776 and 1810-1815. Failure to do so shall constitute a default under this Contract.

15.7.E. Contractor and its Subcontractors shall be responsible for compliance with Labor

Code Section 1776.

- 15.7.F. Contractor and Subcontractors must keep accurate payroll records, showing the name, address, social security number, Work classification, straight time and overtime hours worked each Day and week, and the actual per diem wages paid to each journeyman, apprentice, worker, or other employee employed by him or her in connection with the Work of the Contract documents. Each payroll record shall contain or be verified by a written declaration as required by Labor Code Section 1776.
- 15.7.G. The payroll records enumerated above must be certified and shall be available for inspection at all reasonable hours at the principal office of Contractor as required by Labor Code Section 1776.
 - 15.7.G.1. Contractor shall inform County of the location of records enumerated above, including the street address, city and county, and shall, within five working Days, provide a notice of a change of location and address.
 - 15.7.G.2. Contractor or Subcontractor has 10 Days in which to comply subsequent to receipt of a written notice requesting the records enumerated above. In the event that Contractor or Subcontractor fails to comply with the ten-Day period, he or she shall, as a penalty to County on whose behalf the contract is made or awarded, forfeit \$25.00 for each calendar Day, or portion thereof, for each worker, until strict compliance is effectuated. Upon the request of the Division of Apprenticeship Standards or the Division of Labor Standards Enforcement, these penalties shall be withheld from progress payments then due. Contractor is not subject to a penalty assessment pursuant to this subparagraph due to the failure of a Subcontractor to comply with this subparagraph.
- 15.7.H. This project is subject to compliance monitoring and enforcement by the Department of Industrial Relations. Contractor shall and shall require all subcontractors to furnish the records specified in Labor Code 1776 (e.g. electronic certified payroll records) directly to the Labor Commissioner in a format prescribed by the Labor Commissioner at least monthly.
- 15.7.I. Contractor and all Subcontractors shall be registered and qualified to perform public work pursuant to Labor Code section 1725.5 as a condition to engage in the performance of any Work hereunder.
- 15.7.J. Contractor shall also deliver certified payrolls to County with each Application for Payment as described in Section 001200 (Price and Payment Procedures).**[FOR CONSIDERATION]**

15.8 Environmental Controls

- 15.8.A. Contractor shall comply with all rules, regulations, ordinances, and statutes that apply to any Work performed under the Contract Documents including, without limitation, any toxic, water, and soil pollution controls and air pollution controls specified in Government Code Section 11017. Contractor shall be responsible for insuring that Contractor's Employees, Subcontractors, and the public are protected from exposure to airborne hazards or contaminated water, soil, or other toxic materials used during or generated by activities on the Site or associated with the Project.

15.9 Shoring Safety Plan

- 15.9.A. At least five Days in advance of excavating any trench five feet or more in depth, Contractor shall submit to County a detailed plan showing the shoring, bracing and sloping design and other provisions to be made for worker protection from the hazard of caving ground during the excavation, as required by Labor Code Section 6705. A civil or structural engineer registered in California shall prepare and sign any plan that varies from the shoring system standards established by the State Construction Safety Orders.
- 15.9.B. During the course of Work, Contractor shall be responsible for determining where sloping, shoring, and/or bracing is necessary and the adequacy of the design, installation, and maintenance of all shoring and bracing for all excavation, including

any excavation less than five feet in depth. Contractor will be solely responsible for any damage or injuries that may result from excavating or trenching. County's acceptance of any drawings showing the shoring or bracing design or work schedule shall not relieve Contractor of its responsibilities under this subparagraph.

15.9.C. Cal/OSHA Permit. Contractor shall comply with Labor Code 6500 and shall obtain, as applicable, a permit as required by Cal/OSHA for each of the following:

15.9.C.1. Construction of trenches or excavations that are five feet or more in depth and into which a person is required to descend.

15.9.C.2. Construction or demolition of any building, structure, or scaffolding for falsework more than three stories high, or the equivalent height (36 feet).

15.9.C.3. Erection or dismantling of vertical shoring systems more than three stories high, or the equivalent height (36 feet).

15.9.C.4. The underground use of diesel engines in mines or tunnels.

END OF DOCUMENT

SCOPE OF SERVICES NEPA DOCUMENTATION FOR PERIMETER FENCING PROJECT AT CHARLES M. SCHULZ – SONOMA COUNTY AIRPORT

This document describes the scope of services (Services) to be performed by the RS&H Team (RS&H, LSA Associates, and Mead and Hunt) in connection with the preparation of an Environmental Assessment (EA) in compliance with the National Environmental Policy Act (NEPA) for the proposed security fencing project (the Proposed Action) at Charles M. Schulz – Sonoma County Airport (STS or the Airport). The EA will provide the required NEPA documentation necessary to implement the Proposed Action.

TASK 1 AGENCY SCOPING

The RS&H Team will conduct agency scoping with State, Federal, and local agencies as part of the NEPA process. The RS&H Team will identify relevant State, Federal, and local agencies, then draft scoping letters announcing the preparation of the EA. The initial coordination letters will include a summary of the Proposed Action and supporting materials, such as mapping.

TASK 2 DEVELOP PROJECT DESCRIPTION

The RS&H Team will develop a project description, purpose and need, and a range of alternatives needed for impact analysis and coordination purposes.

Task 2.1 Formulation of Proposed Action

The RS&H Team will clearly define the Proposed Action using metrics such as square feet and linear feet using a combination of text and geographic information systems (GIS) mapping.

Task 2.2 Preparation of Purpose and Need Statement

The RS&H Team will prepare the purpose and need section of the EA. The purpose and need for the Proposed Action will identify the problems currently faced by the Airport and the benefits of implementing the Proposed Action.

Task 2.3 Identification of Alignment Alternatives

The RS&H Team will provide up to three (3) design alternatives for the perimeter fencing improvements. Design alternatives will be prepared in accordance with Part 139 CertAlert No. 16-03 dated August 3, 2016. Using the Plan for Infrastructure Improvements for Deer Exclusion at the Charles M. Schulz-Sonoma County Airport letter developed by LSA and dated February 15, 2016, the RS&H Team will prepare design alternatives with narrative descriptions that incorporate the following elements:

1. Barbed-wire outriggers. Addition of 3-strand barbed-wire outrigger on existing 8-foot segments of the perimeter fence.
2. Fence closure gaps. Three (3) locations on the perimeter do not have 8-foot fence. These locations will be replaced with new 8-foot fence, 3-strand barbed-wire outriggers, and a buried skirt that extends up to 5 feet laterally outward from the fence.
3. Box culvert closure. Alternatives will be prepared to close the box culvert opening at confluence of Lower Ordinance Creek and Airport Creek.

4. Creek Crossings. Alternatives routes will be investigated and alternative designs will be prepared to close the gap in the portion of the fence that crosses Airport Creek at Windsor Road, Airport Creek north of Wastewater Treatment Plan, and Redwood Creek south of the Wastewater Treatment Plant. Alternatives will be designed to exclude deer and other mammals and to minimize the amount of suspended debris that could be trapped during high flows.

Up to three (3) design alternatives will be prepared in accordance with Advisory Circular 150/5370-10G, Subject: Standards for Specifying Construction of Airports, Part 8, Items P-163 and F-164. One (1) revision to the alternatives will be prepared based on review comments. The design alternatives will be prepared and presented in the following format:

1. Preliminary plan title sheet.
2. Project layout plan.
3. Creek crossing profiles, if required.
4. Detail plans.

Task 2.4 Evaluation of Alternatives

The RS&H Team will develop screening criteria for evaluating each alignment alternative. The screening criteria will assess each alignment alternative created as part of **Task 2.3** on the basis of:

- The ability of the alignment alternative to satisfy the Purpose and Need for the Proposed Action.
- The environmental impacts that would occur.
- The constructability variables that affect feasibility.

The screening criteria will be used to assess each element of the alignment alternatives. The evaluation will conclude with the selection of the sponsor's preferred alternative.

TASK 3 PREPARE AFFECTED ENVIRONMENT

This task involved documenting existing conditions using information gathered during field investigations, consultation with Airport staff, and published databases. The RS&H Team will compile information as necessary for various disciplines such as air quality, noise and compatible land use, socioeconomics, environmental justice, and children's environmental health and safety risks, historical architectural, archeological, and cultural resources, biological resources, water resources, and hazardous materials, solid waste, and pollution prevention. If the Proposed Action would have no effect on a particular resource category listed in the FAA Order 1050.1F, then a short summary to that effect will be incorporated in the affected environment section of the EA and the resource category will not be discussed in the Environmental Consequences section of the EA.

TASK 4 PREPARE IMPACT ANALYSIS

The RS&H Team will conduct an environmental impact analysis to identify the anticipated environmental effects associated with implementing the Proposed Action. The environmental consequences section of the EA will be prepared in accordance with FAA Order 1050.1F (*Environmental Impacts: Policies and Procedures*), and FAA Order 5050.4B (*NEPA Implementing Instructions for Airport Actions*).

Task 4.1 Air Quality

The Airport is currently in marginal nonattainment for 8-hour ozone (O₃), moderate nonattainment for fine particulate matter (PM_{2.5}), and was designated as a maintenance zone for carbon monoxide (CO) in June of 1998. The RS&H Team will detail how the Proposed Action is presumed to conform under #8, *Airport Security* on the presumed to conform list and not subject to General Conformity requirements.

This section will document relevant FAA guidelines in concluding that an analysis of the potential for pollutant concentrations to exceed the National Ambient Air Quality Standards (NAAQS) is not required. If coordination with any Federal, State, or local agencies indicates that a construction emission inventory is needed, the RS&H Team will prepare a supplemental scope of work and cost estimate to conduct a construction emission inventory as a separate task.

Task 4.2 Biological Resources

The RS&H Team will incorporate the biological resources analysis conducted as part of the ALP Narrative Tasks into the EA.

Task 4.3 Climate

The RS&H Team anticipates that the Proposed Action is presumed to conform under general conformity. As such, no emission inventory would be completed as part of the air quality or climate sections of the EA. This will be disclosed in the affected environment section noted that no further analysis is required.

Task 4.4 Coastal Resources

The RS&H Team will identify the absence of coastal resources at the Airport in the affected environment section of the EA and note that no further analysis is required.

Task 4.5 Department of Transportation Section 4(f) Lands

Using published data sources including the National Register of Historic Places, maps of public parks, recreational areas, and wildlife refuges, the RS&H Team will determine if the Proposed Action would result in direct or constructive use of any Section 4(f) property.

Task 4.6 Farmlands

The RS&H Team will indicate that the Proposed Action would be constructed on land purchased in 1949, prior to the passage of the Farmland Protection Policy Act (FPPA) and that no further analysis is required.

Task 4.7 Hazardous Materials, Pollution Prevention, and Solid Waste

The RS&H Team will incorporate the hazardous materials, pollution prevention, and solid waste analysis conducted as part of the ALP Narrative Tasks into the EA.

Task 4.8 Historic, Architectural, Archaeological, and Cultural Resources

The RS&H Team will incorporate the historic, architectural, archaeological, and cultural resources analysis conducted as part of the ALP Narrative Tasks into the EA.

Task 4.9 Land Use

The RS&H Team will incorporate the land use analysis conducted as part of the ALP Narrative Tasks into the EA.

Task 4.10 Natural Resources, Energy Supply, and Sustainable Design

The RS&H Team will incorporate the natural resources, energy supply, and sustainable design analysis conducted as part of the ALP Narrative Tasks into the EA.

Task 4.11 Noise and Noise Compatible Land Use

The RS&H Team will incorporate the noise analysis conducted as part of the ALP Narrative Tasks into the EA.

Task 4.12 Socioeconomic Impacts, Environmental Justice, and Children’s Health and Safety

The RS&H Team will prepare a discussion on the effects of the Proposed Action on existing neighborhood or housing development, including any business or residential relocations induced by the Proposed Action. The RS&H Team will detail the effect, if any on the health and safety of children.

Task 4.13 Visual Effects

The RS&H Team will describe the existing visual character in the study area and indicate whether any designated scenic highways exist within the study area. The RS&H Team will describe the change in visual impacts that would occur as a result of the Proposed Action and determine whether any impacts to designated scenic highways within the study area will occur.

Task 4.14 Water Resources

This section includes wetlands, floodplains, surface waters, groundwater, and wild and scenic rivers.

Task 4.14a Wetlands

The RS&H Team will incorporate the wetlands analysis conducted as part of the ALP Narrative Tasks into the EA.

Task 4.14b Floodplains

The RS&H Team will incorporate the floodplains analysis conducted as part of the ALP Narrative Tasks into the EA.

Task 4.14c Surface Waters

The RS&H Team will incorporate the surface waters analysis conducted as part of the ALP Narrative Tasks into the EA.

Task 4.14d Groundwater

The RS&H Team will incorporate the groundwater analysis conducted as part of the ALP Narrative Tasks into the EA.

Task 4.14e Wild and Scenic Rivers

The RS&H Team will incorporate the wild and scenic rivers analysis conducted as part of the ALP Narrative Tasks into the EA.

Task 4.15 Cumulative Impacts

The RS&H Team will incorporate the cumulative impacts analysis conducted as part of the ALP Narrative Tasks into the EA.

TASK 5 PREPARE PRELIMINARY DRAFT EA

The purpose of this task is to prepare a preliminary draft document for County and FAA review. Sonoma County staff would review and provide comments to the RS&H Team prior to FAA review of the EA. The RS&H Team will provide electronic and hard copies (PDF and/or Word documents) of the EA and any appended materials for County and FAA review. The RS&H Team will address comments raised during the review of the EA by the County and the FAA. A conference call may be conducted as part of this task to reconcile comments from reviewers, provide additional clarification, and agree upon the necessary revisions.

TASK 6 PUBLISH DRAFT EA

This task involves the subtasks required for the publication of the Draft EA.

Task 6.1 Publish Draft EA

This task includes the publication of the Draft EA for public and agency review. The RS&H Team will provide agencies with hard paper copies and electronic CD copies. The Draft EA will be circulated to agreed-upon locations accessible to the public.

Task 6.2 Prepare Notice of Availability

The RS&H Team will publish a notice that indicates the availability of the Draft EA in chosen public locations for a 30-day period in a newspaper of general circulation

TASK 7 PREPARE PRELIMINARY FINAL EA

The RS&H Team will address comments received by members of the public and interested agencies as part of this task.

Task 7.1 Review Comments on Draft EA and Prepare Response to Comments Document

The RS&H Team will review comments received during the 30-day comment period and prepare a formal response to comments document that will be appended into the Final EA.

Task 7.2 Prepare Preliminary Final EA

The RS&H Team will modify the Draft EA consistent with comments received during the 30-day review period.

TASK 8 PUBLISH FINAL EA

The RS&H Team will produce hardcopies and CDs of the Final EA for distribution, as requested. The RS&H Team will distribute the Final EA based on the distribution list prepared in previous tasks. It is anticipated that the County will place an electronic copy (Adobe Acrobat - .pdf) of the Final EA on the Airport's website, if necessary.

TASK 9 PUBLIC OUTREACH

This task involves the preparation of a public outreach plan, participation in the public outreach meeting, and preparation of materials needed to conduct public outreach.

Task 9.1 Develop Public Outreach Plan

The RS&H Team will prepare a public outreach program that satisfies the NEPA requirements for public involvement.

Task 9.2 Develop Public Outreach Materials

The RS&H Team will develop maps, handouts, and other materials needed to conduct the public meeting.

Task 9.3 Conduct Public Meeting Workshop

The RS&H Team will conduct one combined public outreach meeting to address any questions members of the public may have about the Draft EA.

TASK 10 PROJECT MANAGEMENT FOR NEPA DOCUMENTATION

This task involves the preparation of a project management plan, participation in meetings with the FAA, and management of the overall project.

Task 10.1 Develop Project Management Plan

The RS&H Team will develop a Project Management Plan (PMP) that incorporates overall project management and administrative needs of the NEPA process. The PMP will outline the following ongoing tasks:

- Monitor project progress;
- Ensure the technical accuracy of all deliverables through quality control review; and
- Participate in monthly updates regarding the progress of the NEPA documentation.

Task 10.2 Meetings with the FAA

The RS&H Team will conduct up to two in-person meetings with the FAA and will participate in up to three teleconference meetings with the FAA.

Task 10.3 NEPA-Related Project Management Tasks

As part of the responsibilities for performing overall project management and administration of the NEPA documentation, the RS&H Team will monitor project progress and ensure that all NEPA-related work products are subject to a Quality Assurance / Quality Control process.

FEE:

Please see Attachment A for Project Costs.

SCHEDULE:

Please see Attachment B for the Project Schedule.

SCOPE OF SERVICES CEQA DOCUMENTATION FOR PERIMETER FENCING PROJECT AT CHARLES M. SCHULZ – SONOMA COUNTY AIRPORT

This document describes the scope of services (Services) to be performed by the RS&H Team (RS&H, LSA Associates, and Mead and Hunt) in connection with the preparation of an initial study (IS) and Mitigated Negative Declaration (MND) in compliance with the California Environmental Quality Act (CEQA) for the proposed security fencing project (the Proposed Project) at Charles M. Schulz – Sonoma County Airport (STS or the Airport). The IS will examine all categories listed in Appendix G of the CEQA Environmental Checklist and will be used to prepare the MND. This scope of services begins at Task 11 because the scope of services for National Environmental Policy Act (NEPA) documentation includes Tasks 1 through 10.

TASK 11 NOTICE OF PREPARATION

The RS&H Team will conduct initial coordination with State, Federal, and local agencies as part CEQA process. The RS&H Team will identify relevant State, Federal, and local agencies, then draft a notice of preparation (NOP) announcing the preparation of the IS/MND.

TASK 12 PROPOSED PROJECT DEFINITION

The RS&H Team will prepare a narrative describing the Proposed Project, the goal of the Proposed Project, and an identification of the individual components associated with the Proposed Project. The RS&H Team will include graphics and tables that are deemed appropriate for describing the Proposed Project. The IS and MND will not include an alternatives analysis, the Proposed Project will be the preferred alternative selected during the alternatives analysis of the environmental assessment (EA)/National Environmental Policy Act (NEPA) process.

TASK 13 PREPARE ADMINISTRATIVE DRAFT INITIAL STUDY

In accordance with the guidelines of the California Environmental Quality Act (CEQA), the RS&H Team will prepare an Initial Study (IS) that provides an analysis of the potential environmental effects associated with implementation of the Proposed Project. Using the analyses completed as part of Task 4, the RS&H Team will provide a summary of potential environmental effects in the resource categories described in Appendix G of CEQA Guidelines:

- Aesthetics
- Agricultural Resources
- Air Quality
- Biological Resources
- Cultural Resources
- Geology/Soils
- Hazards & Hazardous Materials
- Hydrology/Water Quality
- Land Use/Planning
- Utilities and Service Systems
- Mandatory Findings of Significance
- Mineral Resources
- Noise
- Population and Housing
- Public Services
- Recreation

- Transportation/Traffic

The RS&H Team will submit the Administrative Draft IS to the County for review.

TASK 14 PUBLISH INITIAL STUDY

This task involves the publication of the Initial Study.

Task 14.1 Publish Initial Study

Upon Approval by the County, the Initial Study will be mailed or distributed electronically to be made publically available for the duration of the review process.

Task 14.2 Prepare Notice of Availability

The RS&H Team will prepare a notice of public availability for publication in the local newspaper. The Initial Study will be made available for public review for 30 days.

TASK 15 PREPARE MITIGATED NEGATIVE DECLARATION

This task includes the subtasks necessary for the preparation and publication of the MND.

Task 15.1 Prepare Draft Mitigated Negative Declaration

On the basis of the IS, the RS&H Team will prepare a Draft MND and submit the document to the County for review.

Task 15.2 Publish Mitigated Negative Declaration

Following public review of the Draft MND, the RS&H Team will incorporate comments into the Final MND. Upon approval of the Final MND by the County, the RS&H Team will submit the Final MND to the Sonoma County Clerk.

TASK 16 PUBLIC OUTREACH

This task involves the preparation of a public outreach plan, participation in the public outreach meeting, and preparation of materials needed to conduct public outreach.

Task 16.1 Develop Public Outreach Plan

The RS&H Team will prepare a public outreach program that satisfies CEQA requirements for public involvement.

Task 16.2 Develop Public Outreach Materials

The RS&H Team will develop maps, handouts, and other materials needed to conduct the public meeting.

Task 16.3 Conduct Public Meeting

The RS&H Team will conduct one combined public outreach meeting to address any questions members of the public may have about the IS.

TASK 17 PROJECT MANAGEMENT FOR CEQA DOCUMENTATION

This task involves the participation in meetings with the County and management of the overall project.

Task 17.1 Meetings with Sonoma County

The RS&H Team will conduct one in-person meeting with the County and will participate in bi-weekly teleconference project update meetings with the County.

Task 17.2 CEQA-Related Project Management Tasks

The RS&H Team will monitor project progress and ensure that all CEQA-related work products are subject to a Quality Assurance / Quality Control process.

FEE:

Please see Attachment A for Project Costs.

SCHEDULE:

Please see Attachment B for the Project Schedule.

Attachment A - Total Cost

NEPA DOCUMENTATION

TASKS	NEPA Costs	CEQA Reimbursable Costs	CEQA Non-Reimbursable Costs	TOTAL
Task 1 Initial Agency Coordination				
Subtotal	\$5,268			\$5,268
Task 2: Develop Project Description				
Subtotal	\$24,230			\$24,230
Task 3: Prepare Affected Environment				
Subtotal	\$8,091			\$8,091
Task 4: Prepare Impact Analysis				
Subtotal	\$18,430			\$18,430
Task 5: Prepare Preliminary Draft EA				
Subtotal	\$4,957			\$4,957
Task 6: Publish Draft EA				
Subtotal	\$10,257			\$10,257
Task 7: Prepare Preliminary Final EA				
Subtotal	\$9,430			\$9,430
Task 8: Publish Final EA				
Subtotal	\$4,885			\$4,885
Task 9: Public Outreach				
Subtotal	\$12,423			\$12,423
Task 10: Project Management for NEPA				
Subtotal	\$13,717			\$13,717

NEPA DOCUMENTATION SUBTOTAL \$ 111,689 \$ - \$ - \$ 111,689

CEQA DOCUMENTATION

Task 11 Notice of Preparation				
Subtotal	\$2,147			\$2,147
Task 12 Proposed Project Definition				
Subtotal	\$1,957			\$1,957
Task 13: Prepare Administrative Draft Initial				
Subtotal		\$12,283	\$1,074	\$13,357
Task 14: Publish Initial Study				
Subtotal		\$3,003		\$3,003
Task 15: Prepare Mitigated Negative				
Subtotal		\$4,514		\$4,514
Task 16: Public Outreach				
Subtotal	\$5,512			\$5,512
Task 17: Project Management for CEQA				
Subtotal		\$5,713	\$7,714	\$13,427

CEQA DOCUMENTATION SUBTOTAL \$ 9,617 \$ 25,514 \$ 8,788 \$ 43,918

GRAND TOTAL \$ 121,306 \$ 25,514 \$ 8,788 \$ 155,607

Exhibit E

With respect to performance of work under this Agreement, Consultant shall maintain and shall require all of its subcontractors, consultants, and other agents to maintain insurance as described below unless such insurance has been expressly waived by the attachment of a *Waiver of Insurance Requirements*. Any requirement for insurance to be maintained after completion of the work shall survive this Agreement.

County reserves the right to review any and all of the required insurance policies and/or endorsements, but has no obligation to do so. Failure to demand evidence of full compliance with the insurance requirements set forth in this Agreement or failure to identify any insurance deficiency shall not relieve Consultant from, nor be construed or deemed a waiver of, its obligation to maintain the required insurance at all times during the performance of this Agreement.

1. Workers Compensation and Employers Liability Insurance

- a. Required if Consultant has employees as defined by the Labor Code of the State of California.
- b. Workers Compensation insurance with statutory limits as required by the Labor Code of the State of California.
- c. Employers Liability with minimum limits of \$1,000,000 per Accident; \$1,000,000 Disease per employee; \$1,000,000 Disease per policy.
- d. Required Evidence of Insurance: Certificate of Insurance.

If Consultant currently has no employees as defined by the Labor Code of the State of California, Consultant agrees to obtain the above-specified Workers Compensation and Employers Liability insurance should employees be engaged during the term of this Agreement or any extensions of the term.

2. General Liability Insurance

- a. Commercial General Liability Insurance on a standard occurrence form, no less broad than Insurance Services Office (ISO) form CG 00 01.
- b. Minimum Limits: \$1,000,000 per Occurrence; \$2,000,000 General Aggregate; \$2,000,000 Products/Completed Operations Aggregate. The required limits may be provided by a combination of General Liability Insurance and Commercial Excess or Commercial Umbrella Liability Insurance. If Consultant maintains higher limits than the specified minimum limits, County requires and shall be entitled to coverage for the higher limits maintained by Consultant.
- c. Any deductible or self-insured retention shall be shown on the Certificate of Insurance. If the deductible or self-insured retention exceeds \$25,000 it must be approved in advance by County. Consultant is responsible for any deductible or self-insured retention and shall fund it upon County's written request, regardless of whether Consultant has a claim against the insurance or is named as a party in any action involving the County.
- d. County of Sonoma, its officers agents and employees, Attn: Airport Manager, Charles M. Schulz – Sonoma County Airport, 2290 Airport Boulevard, Santa Rosa, CA 95403 shall be endorsed as additional insureds for liability arising out of operations by or on behalf of the

Consultant in the performance of this Agreement.

- e. The insurance provided to the additional insureds shall be primary to, and non-contributory with, any insurance or self-insurance program maintained by them.
- f. The policy definition of “insured contract” shall include assumptions of liability arising out of both ongoing operations and the products-completed operations hazard (broad form contractual liability coverage including the “f” definition of insured contract in ISO form CG 00 01, or equivalent).
- g. The policy shall cover inter-insured suits between the additional insureds and Consultant and include a “separation of insureds” or “severability” clause which treats each insured separately.
- h. Required Evidence of Insurance:
 - i. Copy of the additional insured endorsement or policy language granting additional insured status;
 - ii. Copy of the endorsement or policy language indicating that insurance is primary and non-contributory; and
 - iii. Certificate of Insurance.

3. Automobile Liability Insurance

- a. Minimum Limit: \$1,000,000 combined single limit per accident. The required limits may be provided by a combination of Automobile Liability Insurance and Commercial Excess or Commercial Umbrella Liability Insurance.
- b. Insurance shall cover all owned autos. If Consultant currently owns no autos, Consultant agrees to obtain such insurance should any autos be acquired during the term of this Agreement or any extensions of the term.
- c. Insurance shall cover hired and non-owned autos.
- d. Required Evidence of Insurance: Certificate of Insurance.

4. Professional Liability/Errors and Omissions Insurance

- a. Minimum Limits: \$1,000,000 per claim or per occurrence; \$1,000,000 annual aggregate.
- b. Any deductible or self-insured retention shall be shown on the Certificate of Insurance. If the deductible or self-insured retention exceeds \$25,000 it must be approved in advance by County.
- c. If Consultant’s services include: (1) programming, customization, or maintenance of software: or (2) access to individuals’ private, personally identifiable information, the insurance shall cover:
 - i. Breach of privacy; breach of data; programming errors, failure of work to meet contracted standards, and unauthorized access; and
 - ii. Claims against Consultant arising from the negligence of Consultant, Consultant’s employees and Consultant’s subcontractors.
- d. If the insurance is on a Claims-Made basis, the retroactive date shall be no later than the

commencement of the work.

- e. Coverage applicable to the work performed under this Agreement shall be continued for two (2) years after completion of the work. Such continuation coverage may be provided by one of the following: (1) renewal of the existing policy; (2) an extended reporting period endorsement; or (3) replacement insurance with a retroactive date no later than the commencement of the work under this Agreement.
- f. Required Evidence of Insurance: Certificate of Insurance specifying the limits and the claims-made retroactive date.

5. Standards for Insurance Companies

Insurers, other than the California State Compensation Insurance Fund, shall have an A.M. Best's rating of at least A:VII.

6. Documentation

- a. The Certificate of Insurance must include the following reference: National Environmental Policy Act (NEPA) and California Environmental Quality Act (CEQA Environmental Reviews and Related Services.
- b. All required Evidence of Insurance shall be submitted prior to the execution of this Agreement. Consultant agrees to maintain current Evidence of Insurance on file with County for the entire term of this Agreement and any additional periods if specified in Sections 1 – 4 above.
- c. The name and address for Additional Insured endorsements and Certificates of Insurance is: County of Sonoma, its officers agents and employees, Attn: Airport Manager, Charles M. Schulz – Sonoma County Airport, 2290 Airport Boulevard, Santa Rosa, CA 95403.
- d. Required Evidence of Insurance shall be submitted for any renewal or replacement of a policy that already exists, at least ten (10) days before expiration or other termination of the existing policy.
- e. Consultant shall provide immediate written notice if: (1) any of the required insurance policies is terminated; (2) the limits of any of the required policies are reduced; or (3) the deductible or self-insured retention is increased.
- f. Upon written request, certified copies of required insurance policies must be provided within thirty (30) days.

7. Policy Obligations

Consultant's indemnity and other obligations shall not be limited by the foregoing insurance requirements.

8. Material Breach

If Consultant fails to maintain insurance, which is required pursuant to this Agreement, it shall be deemed a material breach of this Agreement. County, at its sole option, may terminate this Agreement and obtain damages from Consultant resulting from said breach. Alternatively, County may purchase the required insurance, and without further notice to Consultant, County may deduct from sums due to Consultant any premium costs advanced by County for such insurance. These remedies shall be in addition to any other remedies available to County.



County of Sonoma Agenda Item Summary Report

Clerk of the Board
575 Administration Drive
Santa Rosa, CA 95403

Agenda Item Number: 35
(This Section for use by Clerk of the Board Only.)

To: Board of Supervisors

Board Agenda Date: November 13, 2018

Vote Requirement: Majority

Department or Agency Name(s): Transportation and Public Works

Staff Name and Phone Number:

Johannes J. Hoevertsz 707-565-2231

Supervisorial District(s):

Fourth

Title: Landfill Gas Collection System, Operation, Monitoring, Maintenance and Reporting Services for the Healdsburg Closed Landfill.

Recommended Actions:

Authorize the Chair to execute Amendment No. 1 to the Agreement for Landfill Gas Collection Services for the Healdsburg Closed Landfill By and Between the County of Sonoma and SCS Field Services to increase the Task 2 (non-routine services) dollar limit to a not-to-exceed total of \$175,000 per year with no change to term ending March 31, 2020.

Executive Summary:

Transportation and Public Works (TPW) is responsible for the ongoing maintenance of the Healdsburg Landfill, which closed on January 1, 1993. On April 1, 2015, the County entered into a five-year agreement with SCS Field Services to perform routine and non-routine maintenance of the closed landfill. TPW would like increase the not-to-exceed limit total for non-routine tasks from \$50,000 to \$175,000 per year in order to ensure maintenance work can be completed in a timely and effective manner.

Discussion:

TPW oversees and maintains seven closed landfills throughout the County. The Healdsburg Landfill has a leachate, and gas collection system that collects and controls landfill gas (LFG) and leachate to prevent potential impacts off site. In the context of landfills, leachate is any liquid material that drains from the landfill and contains significantly elevated concentrations of undesirable material, typically municipal solid waste, which it has passed through. Monitoring and management of leachate is not only a regulatory requirement for a landfill, but is also an environmental concern.

Non-routine services performed under the existing SCS Field Services agreement may include:

- Responding to the blower/flare station automatic alarm notification system or requests from County personnel.

- Maintaining header lines through preventive maintenance / repair to ensure continued LFG collection and performance for the collection system.
- Maintaining valves, flex hoses and condensate pumps to ensure continued LFG collection and system performance.
- Maintaining below grade LFG and condensate piping to provide for continued LFG extraction performance.
- Extending or relocating LFG extraction wells/and collection system piping to maintain the collection system's function and performance in controlling LFG on site.

Non-routine services are currently capped at \$50,000 per year. This contract amount limits the type of maintenance projects that can be completed within a twelve-month period. There is an immediate need to complete maintenance work involving the installation of additional gas extraction wells, liquid handling pumps, and transmission pipelines in order to avoid a permit violation from the Local Enforcement Agency/CalRecycle. The cost estimate for the work is \$125,000. Increasing the non-routine work limit total from \$50,000 to \$175,000 per year will allow TPW the flexibility to immediately address urgent maintenance needs and avoid potential permit violations.

All work performed for non-routine tasks require prior notification and authorization to proceed by the Director of TPW, or an authorized designee.

Prior Board Actions:

04/07/15: Board approved the Agreement with SCS Field Services for landfill gas collection services for the Healdsburg Closed Landfill.

Strategic Plan Alignment Goal 2: Economic and Environmental Stewardship

This agreement provides for an economic and environmentally sound method of collecting and disposing of landfill gas that complies with State and Federal laws and regulations.

Fiscal Summary			
Expenditures	FY 18-19 Adopted	FY 19-20 Projected	FY 20-21 Projected
Budgeted Expenses	\$50,000	\$175,000	
Additional Appropriation Requested	\$125,000		
Total Expenditures	\$175,000	\$175,000	
Funding Sources			
General Fund/WA GF			
State/Federal			
Fees/Other	\$175,000	\$175,000	
Use of Fund Balance			
Contingencies			
Total Sources	\$175,000	\$175,000	
Narrative Explanation of Fiscal Impacts:			
<p>Total estimated value of non-routine work to be completed by the end of Fiscal Year 18-19 is \$175,000. Appropriations will be requested upon approval of this Amendment through a consolidated budget adjustment. Appropriations for FY 19-20 will be requested as part of the annual budget process.</p> <p>Funding for maintenance at the Healdsburg landfill is stipulated by the Landfill Settlement Agreement (LSA) between the County of Sonoma and the Committed Cities, which became effective on April 1, 2015. The LSA directs the collection of Concession Fees for each ton of Municipal Solid Waste and Organic Waste (Green waste, yard debris, food waste, etc.) that is received at one of five County-owned Solid Waste Facility. There is no financial impact to the General Fund.</p>			
Staffing Impacts			
Position Title (Payroll Classification)	Monthly Salary Range (A – I Step)	Additions (Number)	Deletions (Number)
Narrative Explanation of Staffing Impacts (If Required):			
Attachments:			
Amendment No. 1 to the Agreement for Landfill Gas Collection Services for the Healdsburg Landfill.			

SCS Field Services Proposal for Landfill Gas Extraction System Expansion Services at the Healdsburg Landfill.

Related Items “On File” with the Clerk of the Board:

Agreement for Landfill Gas Collection Services for the Healdsburg Closed Landfill, effective date: April 1, 2015.

Landfill Settlement Agreement between The County of Sonoma and The Committed Cities, effective date: April 1, 2015.

**FIRST AMENDMENT TO
AGREEMENT FOR LANDFILL GAS COLLECTION SERVICES FOR THE
HEALDSBURG CLOSED LANDFILL**

This amendment (“First Amendment”) is entered into as of November 13, 2018 (“Effective Date”) by and between the County of Sonoma (“County”) and SCS Field Services (“Company”).

Recitals

WHEREAS, on April 1, 2015, County and Company entered into an Agreement for Landfill Gas Collection Services for the Healdsburg Closed Landfill (“Original Agreement”); and

WHEREAS, CONTRACTOR represents to County that it is a duly qualified firm experienced in landfill gas collection and control system (GCCS) maintenance and repair; and

WHEREAS, in the judgment of the Board of Supervisors of County, it is necessary and desirable to employ the services of Contractor to perform landfill GCCS maintenance and repair at the Healdsburg Closed Landfill Site (HCLS) to maintain this system in good condition and in compliance with Northern Sonoma County Air Pollution Control District (NSCAPCD) regulations; and

WHEREAS, in the judgment of the Board of Supervisors of County, it is necessary and desirable to employ the services of Contractor to perform maintenance activities at other County-owned landfill sites to maintain existing LCRS, storm drain, and landfill cover systems in good condition and in compliance with applicable regulations.

WHEREAS, County and Company desire to amend the Agreement to increase the Task 2 (Non-Routine) services amount to a not-to-exceed total of \$175,000 per year.

NOW, THEREFORE, in consideration of the foregoing recitals and the mutual covenants contained herein, the parties agree as follows:

A G R E E M E N T

1. Section 2 (Payment) subsection b. (Payment Terms for Task 2) shall be amended to read:

“ b. Payment Terms for Task 2. For all non-routine work performed by Contractor, County agrees to pay, and Contractor agrees to accept compensation on a time and materials basis in accordance with the rates set forth in Exhibit B – Fee Schedule, provided, however, that the total sum of all such labor and expenses related to Extra Work duties shall not exceed One Hundred Seventy Five Thousand and No/100 Dollars (\$175,000.00) per year.”

2. Except to the extent the Agreement is specifically amended or supplemented hereby, the Agreement, together with exhibits, shall continue to be in full force and effect as originally executed, and nothing contained herein shall be construed to modify, invalidate, or otherwise affect any provision of the Agreement or any right of County arising thereunder. All capitalized terms used herein shall, unless otherwise defined, have the meaning ascribed to those terms in the Agreement, as amended.

3. The Recitals are incorporated into and form a part of this First Amendment.

COUNTY AND COMPANY HAVE CAREFULLY READ AND REVIEWED THIS SECOND AMENDMENT AND EACH TERM AND PROVISION CONTAINED HEREIN AND, BY EXECUTION OF THIS SECOND AMENDMENT, SHOW THEIR INFORMED AND VOLUNTARY CONSENT THERETO.

IN WITNESS WHEREOF, County and Company have executed this Second Amendment as of the Effective Date.

CONSULTANT:
SCS FIELD SERVICES

By: _____

Name: _____

Title: _____

Date: _____

COUNTY OF SONOMA, a political subdivision
Of the State of California

Chair
Board of Supervisors

CERTIFICATES OF INSURANCE ON FILE WITH
AND APPROVED AS TO SUBSTANCE FOR COUNTY:

Johannes Hoevertsz, Director
Sonoma County Transportation and Public Works

APPROVED AS TO FORM FOR COUNTY:

Lisa A. Pheatt
Deputy County Counsel

SCS FIELD SERVICES

May 24, 2018
File No.

Mr. Glenn Morelli, PG, C.HG, QSD
County of Sonoma
Transportation and Public Works Department
2300 County Center Drive, Suite B100
Santa Rosa, California 95403

Subject: **Proposal for Landfill Gas Extraction System Expansion Services at the Healdsburg Landfill, Sonoma County, California**

Dear Mr. Morelli:

SCS Field Services (SCS) is pleased to submit this proposal to the County of Sonoma (County) to provide installation services for new vertical landfill gas (LFG) extraction wells and associated pumps and components at the above-referenced site. The scope of work is based on the plans and specifications provided by SCS Engineers dated April 6, 2018, to the County to help in the remediation of perimeter monitoring probe LFG-18 at the closed Healdsburg Landfill.

SCOPE OF WORK

The basic scope of work for this project consists of the installation of two (2) infill LFG extraction wells, two (2) vadose zone extraction wells (optional), three new liquid handling pumps installed into existing wells and appurtenant LFG, air and liquid transmission pipelines. As requested this work has been separated into three phases as shown below.

COST ESTIMATE

Our cost to perform the work described above is shown below and is based on a unit cost basis. SCS understands that prior to performing this work, a mutually agreeable contract/purchase order will be negotiated and executed to enable this work to be performed. Our cost estimate is based on the use of prevailing wage labor rates in accordance with Department of Industrial Relations requirements.

Phase I – Pump Installation into Existing LFG Extraction Well Nos. A-27R, A-28 and A-29

A. Furnish and Install Wellcaps, Pumps and Wellheads

This task includes all equipment, materials, and labor required to furnish and install three (3), Real Environmental Products (REP) Auto Well Series 4000 well transitions, three (3)



VP-2 pneumatic pumps with regulator/cycle counters, down casing tubing (up to 100 feet) and three (3) 2- inch REP Series 3100 Orifice plate wellheads with flex hose. SCS shall be paid according to each wellcap/wellhead/pump installed.

B. Install Above-Grade 2-Inch Diameter SDR 11 Air and Leachate Pipelines

This task includes all labor, materials and equipment required to complete the installation of the above grade 2-inch diameter HDPE pipelines, check and isolation valves for the liquid and air pipelines to connect the pumps to the existing leachate collection systems. SCS shall be paid according to the linear foot of actual 2-inch diameter pipe installed (total estimate 400 feet). Actual total to be determined at time of installation.

Phase II –Install LFG Extraction Well Nos. A-35 and A-36

A. Mobilization/Demobilization

This task includes the purchase and delivery of all construction materials and equipment, the driller's mobilization, and all other activities required such that construction (LFG extraction well drilling/ completion and associated piping installation) may begin the day after mobilization is complete; continuing uninterrupted until completion. Included in the demobilization portion of this task is the cleanup of the job site and removal of temporary facilities. SCS shall be paid for mobilization/demobilization according to a lump sum basis.

B. Standby Time

Drilling, extraction well completion, installation of piping, and other activities that may be halted to accommodate testing or other activities. SCS shall be paid for standby time according to an hourly basis.

C. Drill and Complete 24-Inch Diameter Vertical Single Casing 6-Inch Diameter LFG Extraction Wells

This task includes all materials, labor, and equipment required to drill and complete two (2), 24-inch diameter, single casing 6-inch diameter SDR-11 HDPE vertical LFG extraction wells (estimated total depth 60 lineal feet) backfilled with bentonite, gravel, and native material. Not included (if needed) are grading or any drilling platforms required for installation of the 24-inch diameter vertical wells. SCS shall be paid according to the vertical foot of actual 24-inch diameter vertical well completed.

D. Furnish and Install Wellheads

This task includes all equipment, materials, and labor required to furnish and install two (2), 2-inch REP Series 3100 wellheads with flex hose. SCS shall be paid according to each wellhead installed.

E. Install Above-Grade 4-Inch Diameter SDR 17 LFG Lateral Pipelines

This task includes all labor and equipment required to complete the installation of the above grade 4-inch diameter HDPE pipelines needed to connect the new wells to the existing collection system. SCS shall be paid according to the linear foot of actual 4-inch diameter pipe installed (total estimate 140 feet). SCS shall be paid according to actual lineal feet of pipeline installed.

F. Pipeline Connections to Existing Systems

This task includes all labor, materials and equipment required to complete the connections of the relocated and new pipelines to the existing HDPE pipelines at the site. SCS shall be paid according to each connection performed.

G. Installation of Rebar Staking

This task includes all labor, materials and equipment required to complete the installation of up to five (5) rebar staking units (#5 Bar) with 1-inch PVC sleeves/safety caps. SCS shall be paid according to each set of Rebar Staking installed.

H. Storage Container

This task includes all labor, materials and rental equipment required for the storage of the drilling spoils on site in a covered 20 yard bin to allow for sampling, analysis and disposal by the County. This is a 30 day rental period of a 20 yard bin as needed.

Phase III –Install LFG Extraction Well Nos. VZ-1 and VZ-2 (Optional)

A. Mobilization/Demobilization

This task includes the purchase and delivery of all construction materials and equipment, the driller's mobilization, and all other activities required such that construction (LFG extraction well drilling/ completion and associated piping installation) may begin the day after mobilization is complete; continuing uninterrupted until completion. Included in the demobilization portion of this task is the cleanup of the job site and removal of temporary facilities. SCS shall be paid for mobilization/demobilization according to a lump sum basis.

B. Standby Time

Drilling, extraction well completion, installation of piping, and other activities that may be halted to accommodate testing or other activities. SCS shall be paid for standby time according to an hourly basis.

C. Drill and Complete 24-Inch Diameter Vertical Single Casing 6-Inch Diameter LFG Extraction Wells

This task includes all materials, labor, and equipment required to drill and complete two (2), 24-inch diameter, single casing 6-inch diameter SDR-11 HDPE vertical LFG extraction wells (estimated total depth 100 lineal feet) backfilled with bentonite, gravel, and native material. Not included (if needed) are grading or any drilling platforms required for installation of the 24-inch diameter vertical wells. SCS shall be paid according to the vertical foot of actual 24-inch diameter vertical well completed.

D. Furnish and Install Wellheads

This task includes all equipment, materials, and labor required to furnish and install two (2), 2-inch REP Series 3100 wellheads with flex hose. SCS shall be paid according to each wellhead installed.

E. Install Above-Grade 4-Inch Diameter SDR 17 LFG Lateral Pipelines

This task includes all labor, materials and equipment required to complete the installation of the above grade 4-inch diameter HDPE pipelines needed to connect the new wells to the existing collection system. SCS shall be paid according to the linear foot of actual 4-inch diameter pipe installed (total estimate 400 feet). SCS shall be paid according to actual lineal feet of pipeline installed.

F. Pipeline Connections to Existing Systems

This task includes all labor, materials and equipment required to complete the connections of the relocated and new pipelines to the existing HDPE pipelines at the site. SCS shall be paid according to each connection performed.

G. Installation of Rebar Staking

This task includes all labor, materials and equipment required to complete the installation of up to 20 (20) rebar staking units (#5 Bar) with 1-inch PVC sleeves/safety caps. SCS shall be paid according to each set of Rebar Staking installed.

COMPENSATION

SCS would be pleased to provide the following **budget estimate** unit prices presented in the following cost table:

	Item	Unit	Quantity	Unit Price	Total Price
Phase I – Pump Installation					
A.	Install Wellcaps, wellheads and pumps	Ea	3	\$ 9,500.00	\$ 28,500.00
B	Install 2 inch air and liquid transmissions pipelines	Ft	400	\$ 12.50	\$ 5,000.00
Total Cost Phase I					\$ 33,500.00
Phase II – Install LFG Extraction Wells (A35 and A36)					
	Item	Unit	Quantity	Unit Price	Total Price
A.	Mobilization/Demobilization	LS	1	\$8,500.00	\$ 8,500.00
B.	Standby Time			As Needed	
C.	Drill and Complete 24-Inch Diameter Vertical Single Casing 6-Inch Diameter HDPE or PVC LFG Extraction Wells	LF	60	\$275.00	\$ 16,500.00
D.	Furnish and Install Wellheads	EA	2	\$1,050.00	\$ 2,100.00
E.	Install 4- inch HDPE Lateral Pipelines	LF	100	\$24.50	\$ 2,450.00
F.	Pipeline Connections to Existing Systems	EA	1	\$ 1,000.00	\$ 1,000.00
G.	Installation of Rebar Staking	EA	5	\$ 150.00	750.00
H.	Twenty yard dumpster rental – 30 days	EA	1	\$ 3,500.00	\$ 3,500.00
Total Cost Phase II					\$ 34,800.00
Phase III – Install Vadose Extraction Wells (VZ-1 and VZ-2) (Separate)					
A.	Mobilization/Demobilization	LS		\$8,500.00	\$ 8,500.00
B.	Standby Time			As Needed	
C.	Drill and Complete 24-Inch Diameter Vertical Single Casing 6-Inch Diameter HDPE or PVC LFG Extraction Wells	LF	100	\$275.00	\$ 27,500.00
D.	Furnish and Install Wellheads	EA	2	\$1,050.00	\$ 2,100.00
E.	Install 4- inch HDPE Lateral Pipelines	LF	400	\$ 24.50	\$ 9,800.00
F.	Pipeline Connections to Existing Systems	EA	1	\$ 1,000.00	\$ 1,000.00
G.	Installation of Rebar Staking	EA	20	\$ 125.00	\$ 2,500.00
H.	Twenty yard dumpster rental – 30 days	EA	1	\$3,500.00	\$ 3,500.00
Total Cost Phase III					\$54,900.00
Phase II/III – Install LFG and Vadose Extraction Wells					
A.	Mobilization/Demobilization	LS		\$8,500.00	\$8,500.00
B.	Standby Time			As Needed	
C.	Drill and Complete 24-Inch Diameter Vertical Single Casing 6-Inch Diameter HDPE or PVC LFG Extraction Wells	LF	160	\$245.00	\$39,200.00
D.	Furnish and Install Wellheads	EA	4	\$ 1,000.00	\$ 4,000.00
E.	Install 4- inch HDPE Lateral Pipelines	LF	500	\$ 22.50	\$ 11,250.00
F.	Pipeline Connections to Existing Systems	EA	2	\$ 800.00	\$ 1,600.00

	Item	Unit	Quantity	Unit Price	Total Price
G.	Installation of Rebar Staking	EA	25	\$100.00	\$2,500.00
H.	Twenty yard dumpster rental – 30 days	EA	2	\$ 2,500.00	\$ 5,000.00
Total Cost if Phase II and III performed concurrently					\$ 72,050.00
Total Project Cost if all Phases Separate					\$ 123,200.00
Total Project Cost if Phases I and II/ II are performed concurrently					\$ 105,550.00

CLOSING

If this proposal is acceptable, we understand the County will issue a mutually agreeable contract or purchase order specific to the work to be performed. Formal execution of this contract or purchase order will serve as our notice to proceed.

SCS appreciates this opportunity to assist the County with this important project. If you have any questions, please contact either of the undersigned.

Very truly yours,



Arthur E. Jones Jr
Senior Project Manager
SCS FIELD SERVICES

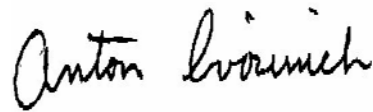

Anton Svorinich
Vice President
SCS FIELD SERVICES

ATTACHMENT A

ASSUMPTIONS AND CONDITIONS

ATTACHMENT A

ASSUMPTIONS AND CONDITIONS FOR THE HEALDSBURG LANDFILL, HEALDSBURG, CALIFORNIA May 24, 2018

- Prevailing wage non-union workers will be utilized as is required by the State of California Department of Industrial Relations Apprenticeship Program. Requirement to use union labor can be offered with an adjustment in our price.
- Unrestricted site access for personnel, equipment, and materials must be provided to enable completion of the work.
- Right-of-way easement, dewatering, or encountering conditions that differ materially from the contract documents or what is reasonably anticipated given the nature of the work (such as hard rock during trenching or drilling) has been excluded from our bid. These items can be included with an adjustment in our price.
- The work will be performed in OSHA Level D protection and in accordance with the SWANA Landfill Gas Management Division, "A Compilation of Landfill Gas Field Practices and Procedures," dated August 2011. Additional health and safety requirements can be provided with an adjustment in our price.
- During LFG well drilling activities, in the event SCS is on site and available to work, but is unable to do so due to delays by others, a standby charge of \$750.00 per hour will be charged for the duration of the delay.
- During other construction activities, not related to LFG well drilling, in the event SCS is on site and available to work, but is unable to do so due to delays by others, a standby charge of \$500.00 per hour will be charged for the duration of the day.
- Any obstruction, hole caving, blockage, ground water or any material not reasonably excavated with the drill rig will be charged as additional work. SCS will attempt to drill in such conditions for a period of 30 minutes prior to notifying the County. If the County decides to continue drilling in these conditions it will be charged as additional work for a rate of \$750.00 per hour.
- In the event of LFG well drilling refusal or abandonment will be charged at \$75.00 per foot.
- Drilling spoils will be placed into covered dumpsters for eventual disposal by others. Costs for disposal are not included in this proposal but can be provided upon completion of testing and evaluation of analytical results.
- Back fill dirt and water is available for use on-site to SCS free of charge for the project.
- The owner is responsible for notifying SCS of any risks at the site and all environmental, safety and health procedures required by any applicable federal, state, and/or local law, regulations, and order.



- The owner is responsible for identifying all underground facilities, including pipelines, conduits, ducts, cables, wires, manholes, vaults, utilities, tanks, tunnels, product lines, etc.
- Handling and disposal of any hazardous materials is excluded from our price.
- SCS will maintain the site in construction clean manner. Control of blowing litter created by others is excluded.
- Bid, performance or payment bonds will not be required.
- Liquidated/delay damages will not be required.
- Any notifications to the Sonoma County Air Pollution Control District will be performed by others.
- The prices detailed are not stand-alone; if items are to be installed separately, SCS reserves the right to modify its prices.
- Dust control is by others. SCS can provide this service with an adjustment in our price.
- The Owner is responsible for notifying contractor of any risks at the site and all environmental, safety and health procedures required by any applicable federal, state, and/or local law, regulations, and order.
- This proposal and Assumptions and Conditions shall become part of a mutually agreeable contract or purchase order.
- At no time shall the title of any hazardous substances, solid wastes, petroleum contaminated or other regulated substances pass to SCS, nor shall any provision of an ensuing Agreement between SCS and the Client be interpreted to permit SCS to assume the status of “generator,” “transporter,” or “treatment, storage or disposal facility” under state or federal law.
- This proposal is considered confidential and proprietary and may not be disclosed to third parties without the prior written approval of SCS.
- Our work excludes any and all surveying. SCS can perform the necessary surveying to enable well installation with an adjustment to our price.
- Any necessary permits will be provided by others.

ATTACHMENT B
PRELIMINARY DESIGN DRAWINGS



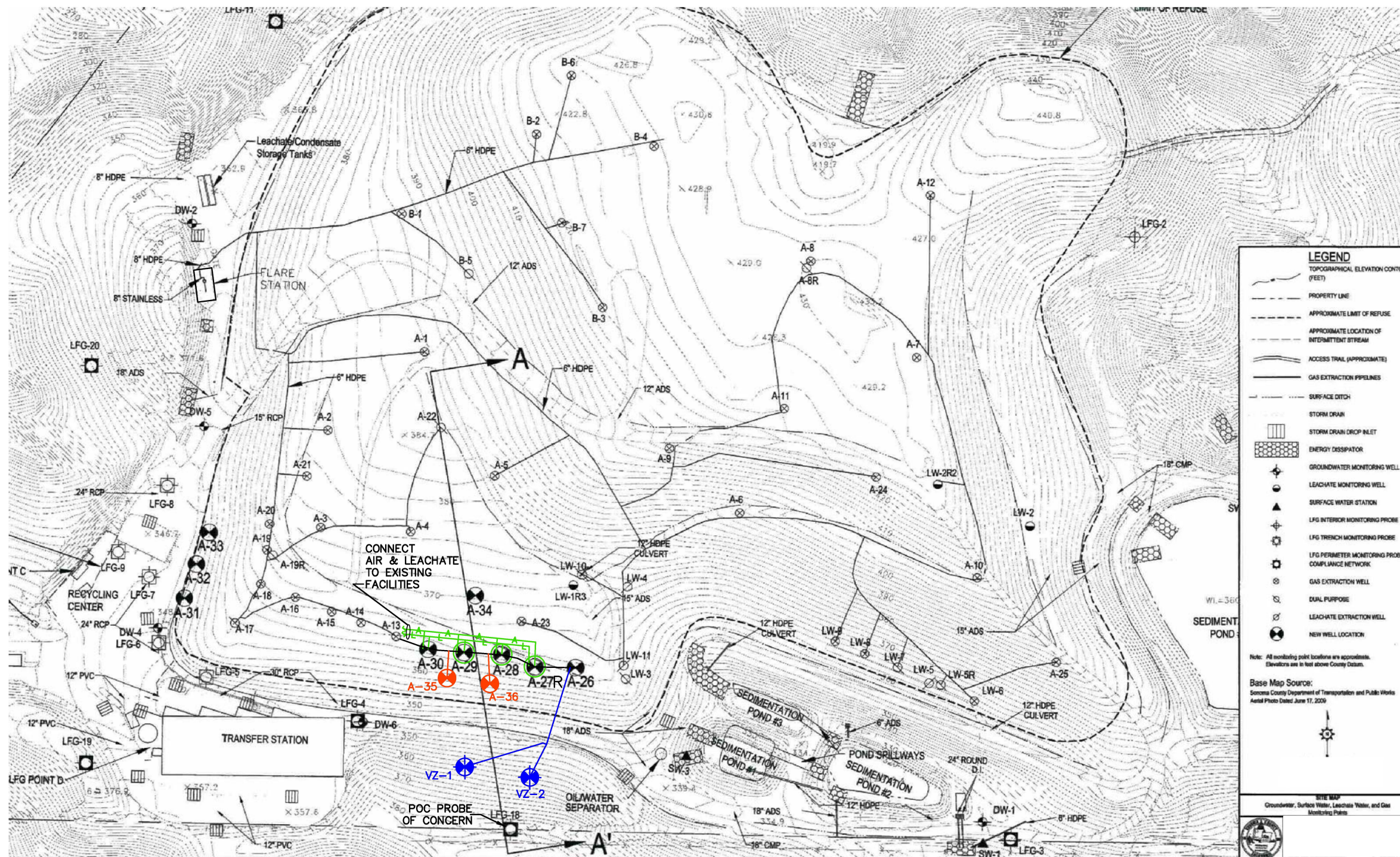

- WORK PLAN LEGEND**
- ▲— NEW LEACHATE RETURN LINE (PHASE 1)
 - ▲— NEW AIRLINE (PHASE 1)
 - ▲— NEW LATERAL (PHASE 2)
 - ▲— NEW LATERAL (PHASE 3)
 - A-28 EXISTING LFG WELL W/ NEW LEACHATE PUMP (PHASE 1)
 - A-35 NEW EXTRACTION WELL (PHASE 2)
 - VZ-1 NEW VADOSE ZONE WELL (PHASE 3)

LEGEND

- TOPOGRAPHICAL ELEVATION CONTOUR (FEET)
- PROPERTY LINE
- APPROXIMATE LIMIT OF REFUSE
- APPROXIMATE LOCATION OF INTERMITTENT STREAM
- ACCESS TRAIL (APPROXIMATE)
- GAS EXTRACTION PIPELINES
- SURFACE DITCH
- STORM DRAIN
- STORM DRAIN DROP INLET
- ENERGY DISSIPATOR
- GROUNDWATER MONITORING WELL
- LEACHATE MONITORING WELL
- SURFACE WATER STATION
- LFG INTERIOR MONITORING PROBE
- LFG TRENCH MONITORING PROBE
- LFG PERIMETER MONITORING PROBE/ COMPLIANCE NETWORK
- GAS EXTRACTION WELL
- DUAL PURPOSE
- LEACHATE EXTRACTION WELL
- NEW WELL LOCATION

Note: All monitoring point locations are approximate. Elevations are in feet above County Datum.

Base Map Source: Sonoma County Department of Transportation and Public Works Aerial Photo Dated June 17, 2009

SITE MAP
Groundwater, Surface Water, Leachate Water, and Gas Monitoring Points

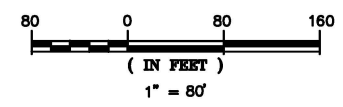

CK BY					
DESCRIPTION					
DATE	03/05/18				
REV	1	2	3	4	5
SHEET TITLE	LFG SYSTEM PLAN				
	PROJECT TITLE	HEADSBURG LANDFILL			
CLIENT	COUNTY OF SONOMA				
	TRANSPORTATION & PUBLIC WORKS				
SC ENGINEERS	STEARN, CONRAD AND SCHMIDT				
	CONSULTING ENGINEERS AND CONTRACTORS				
CADD FILE:	FIG-1GCCS.Plan.030718				
	DATE:	03-05-18			
SCALE:	AS SHOWN				
FIGURE:	1				

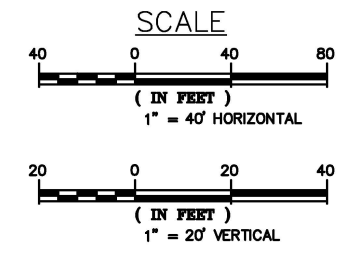
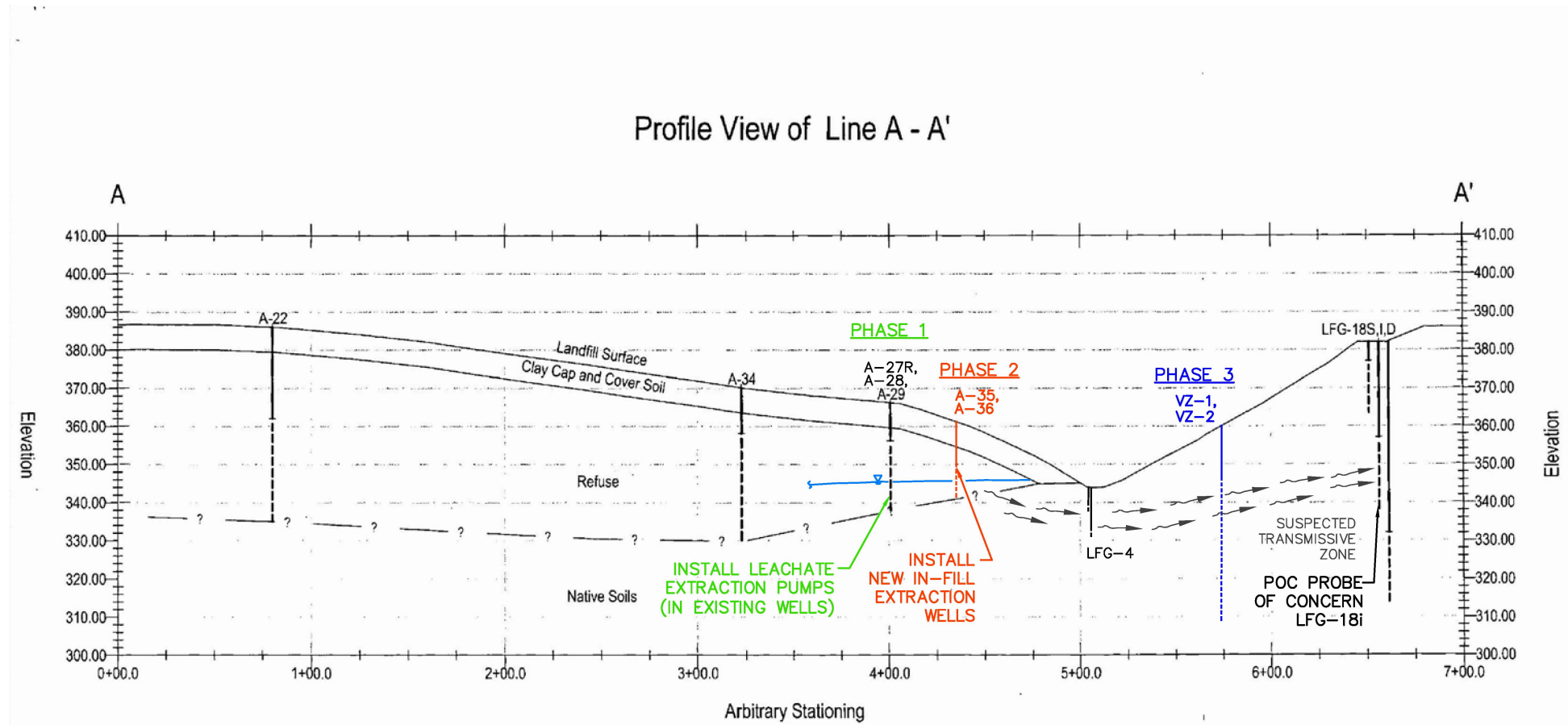

LEGEND

- Solid Well Riser Pipe
- Perforated Well Screen

Topographic Map Source:
Sonoma County Department of Transportation and Public Works
Aerial Photo Dated June 17, 2009

CROSS SECTION A - A'

SITE: HEALDSBURG CLOSED LANDFILL SONOMA COUNTY, CALIFORNIA

File location: R:\Vector\02 Healdsburg LF

CK BY		DESCRIPTION		DATE		REV	
		CONCEPT WORK PLAN		03/05/18		A	
SHEET TITLE		LANDFILL SECTION A-A'					
PROJECT TITLE		HEADSBURG LANDFILL LANDFILL GAS MIGRATION CONTROL WORK PLAN					
CLIENT		COUNTY OF SONOMA TRANSPORTATION & PUBLIC WORKS					
SCEN ENGINEERS		STEARNS, CONRAD, AND SCHMIDT CONSULTING ENGINEERS AND CONTRACTORS 3117 FITE CIRCLE, SUITE 108 SACRAMENTO, CA 95827 PH. (916) 361-1287 FAX. (916) 361-1299 PROJ. NO. 07215049.00 T2 DESK. BY: MJE DRAW. BY: MJE CHECK BY: AAM APP. BY: AAM					
CADD FILE:		FIG-2.SECTION.030718					
DATE:		03-05-18					
SCALE:		AS SHOWN					
FIGURE:		2					

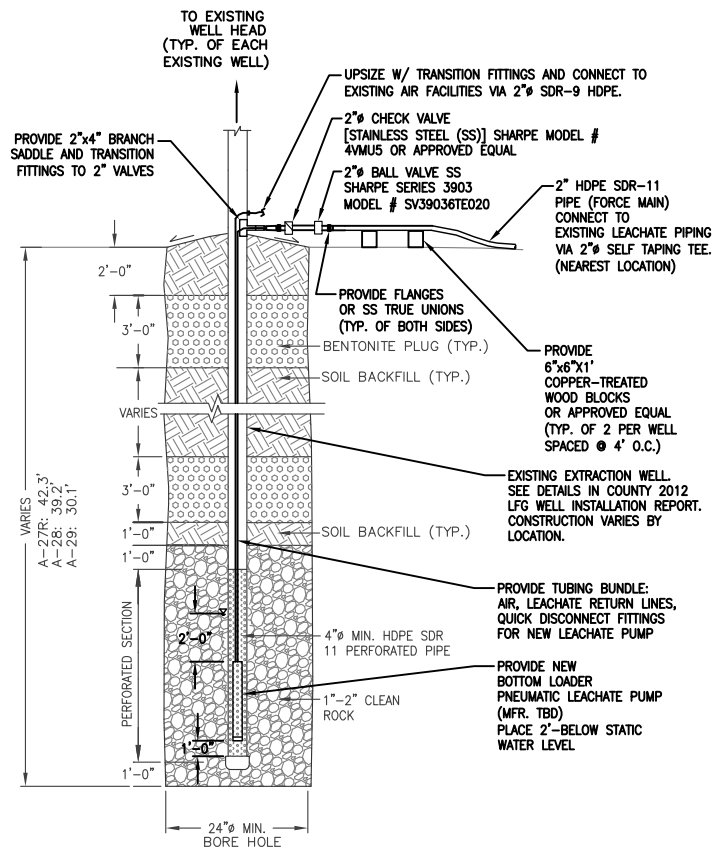

MODIFY WELLS A-27R, A-28, & A-29 EXTRACTION WELLS TO DUAL PURPOSE WELLS BY ADDING NEW LEACHATE PUMPS

- LEACHATE WELL VALVE NOTES:
1. FLANGES SHALL BE PROVIDED IN 2 LOCATIONS: PRIOR TO BALL VALVE AND AFTER CHECK VALVE PRIOR TO TEE ON CLEANOUT UPRISER PIPE.
 2. FLANGES SHALL INCLUDE SS NUTS, BOLTS, AND WASHERS AND BE OF ADEQUATE SIZE/TYPE FOR 4" HDPE FORCE-MAIN PIPE.
 3. BACKING RINGS SHALL BE EPOXY COATED DUCTILE IRON OR APPROVED EQUAL.

1 DETAIL LEACHATE EXTRACTION WELL
N.T.S.

SC ENGINEERS STEARNS, CONRAD AND SCHMIDT CONSULTING ENGINEERS AND CONTRACTORS 3117 FIVE CORNER, SUITE 108 SACRAMENTO, CA 95827 PH. (916) 361-1297 FAX. (916) 361-1299 PROJ. NO. 07215049.00 T2 DESK. BY: MJE DWG. BY: MJE HLF.LFG.030618 APP. BY: AAM	CLIENT COUNTY OF SONOMA TRANSPORTATION & PUBLIC WORKS	SHEET TITLE TYPICAL LEACHATE EXTRACTION WELL PROJECT TITLE HEADSBERG LANDFILL LANDFILL GAS MIGRATION CONTROL WORK PLAN	REV A B C D E	DATE 03/05/18	DESCRIPTION CONCEPT WORK PLAN	CK. BY AAM
	CADD FILE: H.LF LFG WELL_030618 DATE: 03-05-18 SCALE: AS SHOWN FIGURE: 3					

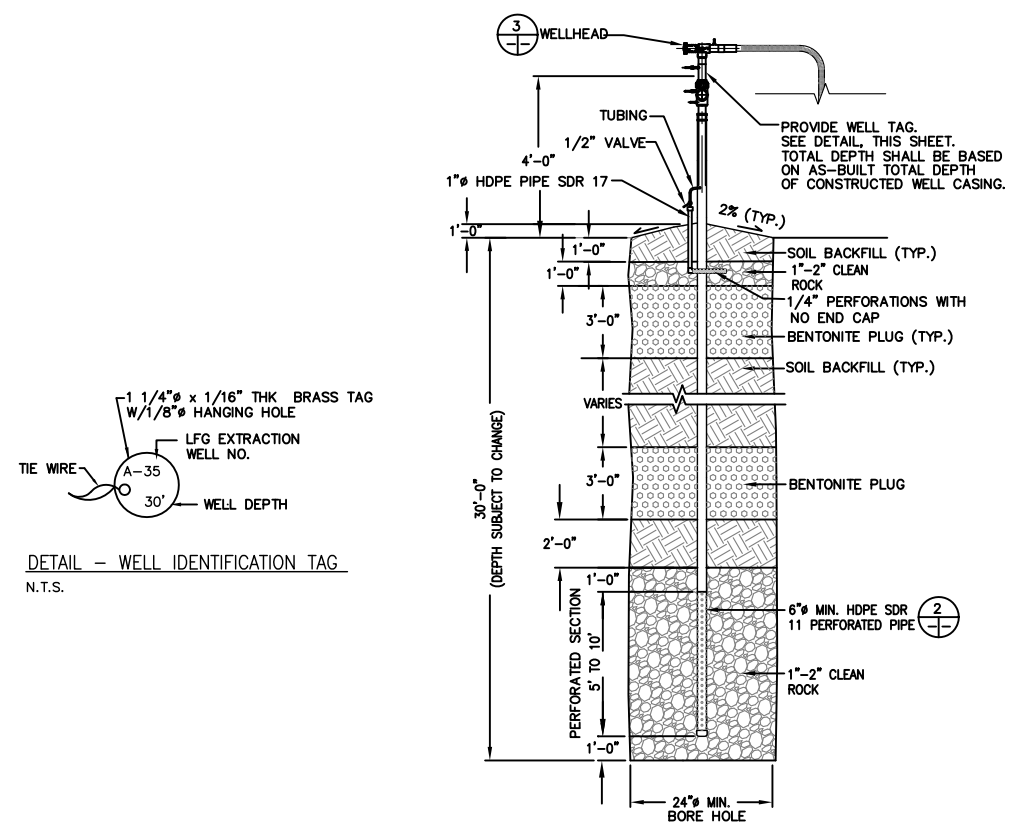

CONCEPT DESIGN FOR LFG EXTRACTION WELLS A-35 & 36

1 DETAIL SINGLE COMPLETION LFG EXTRACTION WELL
N.T.S.

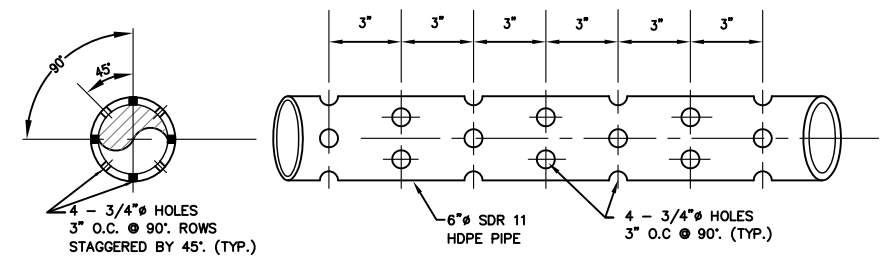

2 DETAIL - HDPE PERFORATED SECTION
N.T.S.

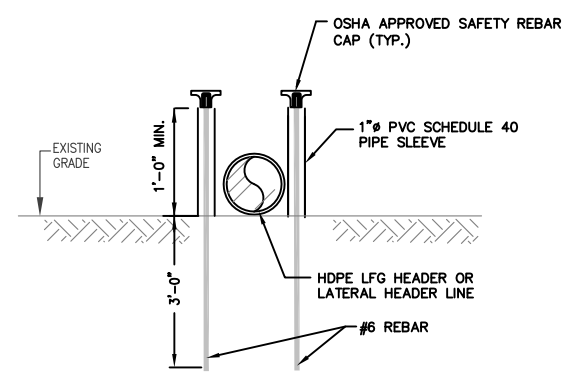

A SECTION - PIPE GUIDE AT GRADE (TYP.)
N.T.S.

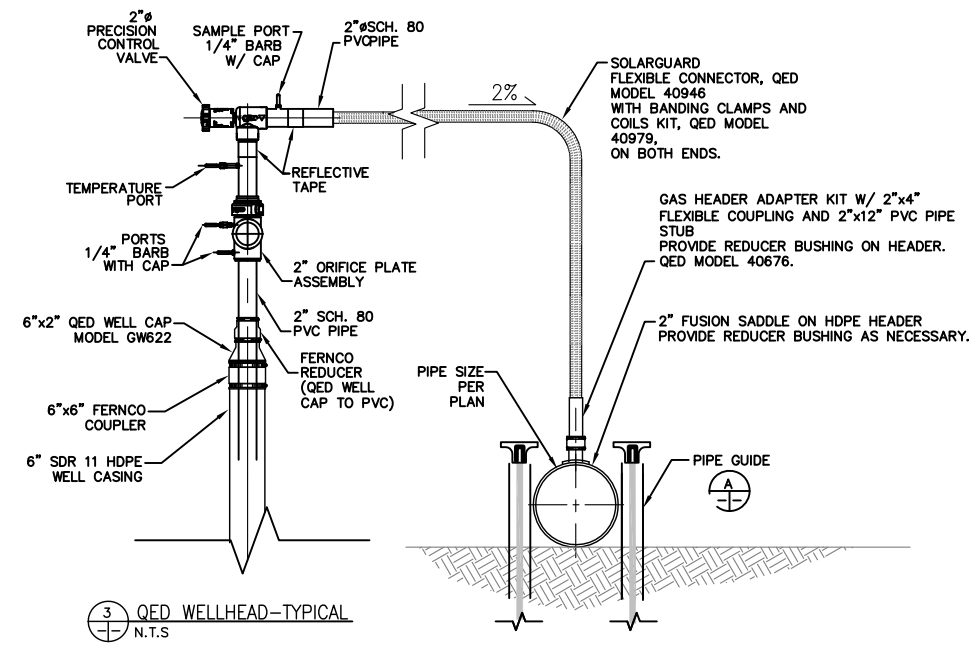

3 QED WELLHEAD - TYPICAL
N.T.S.

REV	DATE	DESCRIPTION	CK. BY	BY
1	03/05/18	CONCEPT WORK PLAN	AAM	
2				
3				
4				

SHEET TITLE	TYPICAL LFG EXTRACTION WELL
PROJECT TITLE	HEADSBERG LANDFILL LANDFILL GAS MIGRATION CONTROL WORK PLAN

CLIENT	COUNTY OF SONOMA TRANSPORTATION & PUBLIC WORKS
--------	---

SC ENGINEERS	
STEARNS, CONRAD AND SCHMIDT CONSULTING ENGINEERS AND CONTRACTORS 3112 FITE CIRCLE, SUITE 108 SACRAMENTO, CA 95827 PH. (916) 361-1297 FAX. (916) 361-1299	
PROJ. NO. 07215049.00 T2	ACAD FILE: HLF.LFG.030618
DRW. BY: MJE	CHK. BY: AAM
APP. BY: MJE	APP. BY: AAM

CADD FILE:	HLF LFG WELL_030618
DATE:	03-05-18
SCALE:	AS SHOWN
FIGURE:	4

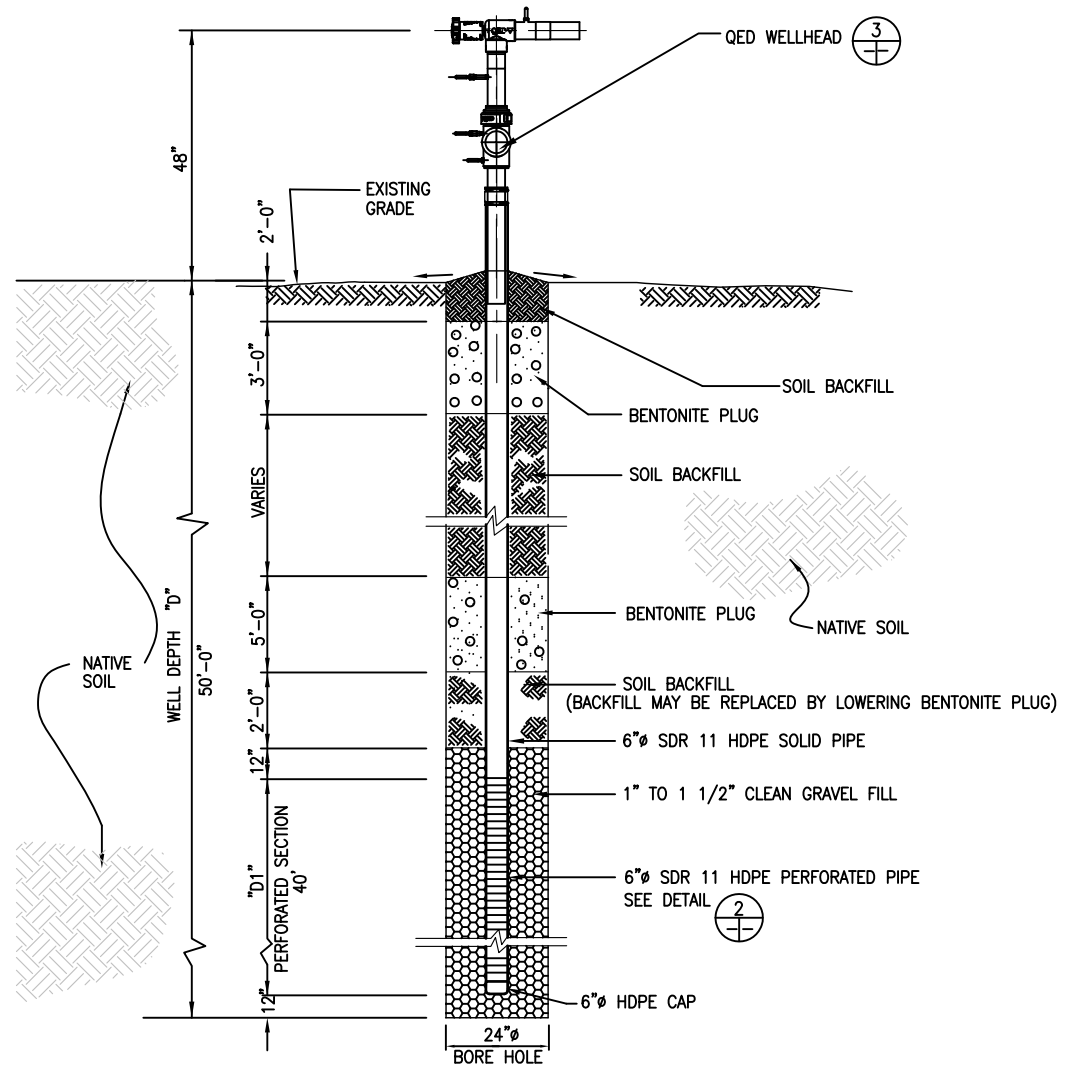

DETAIL - VADOSE ZONE WELLS
N.T.S. VZ-1 & VZ-2

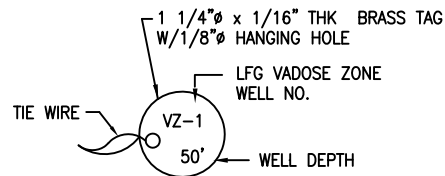

DETAIL - IDENTIFICATION TAG
N.T.S.

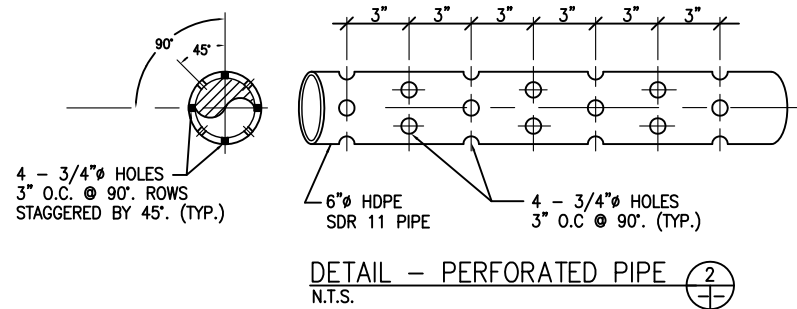

DETAIL - PERFORATED PIPE
N.T.S.

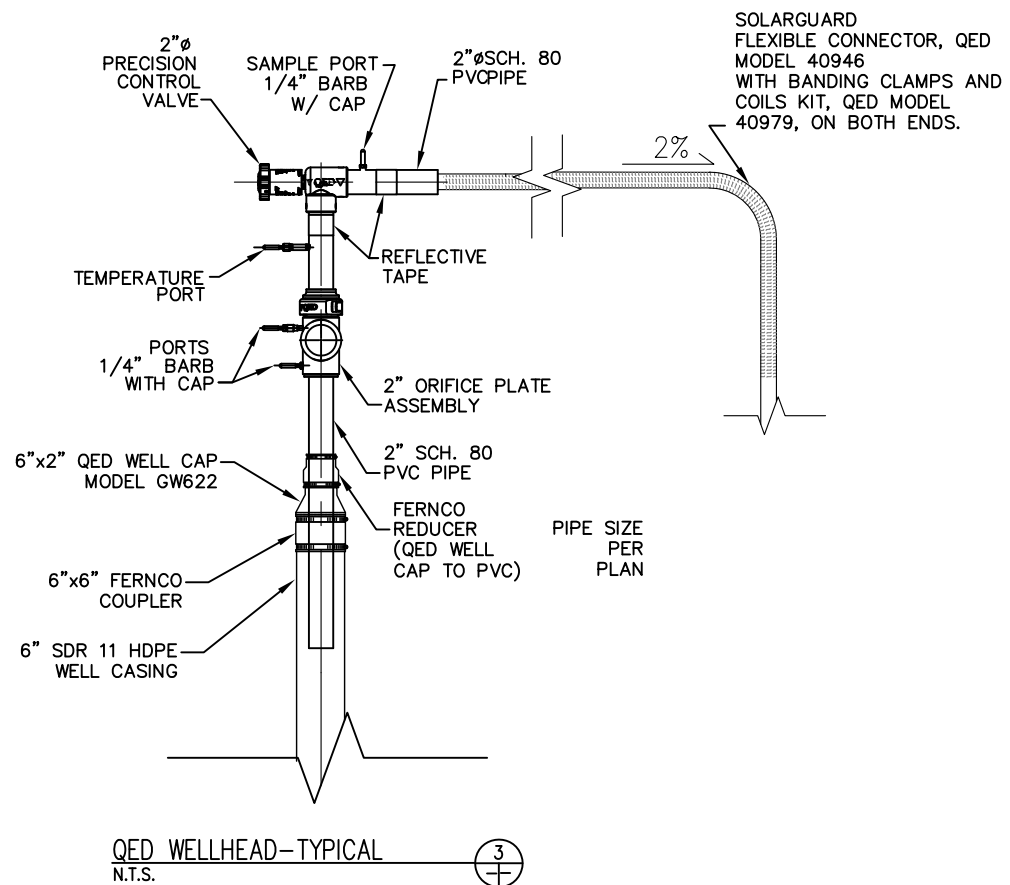

QED WELLHEAD-TYPICAL
N.T.S.

REV	DATE	DESCRIPTION	CK. BY
A	03/05/18	CONCEPT WORK PLAN	AAM

SHEET TITLE
TYPICAL VADOSE ZONE WELL

PROJECT TITLE
HEADSBERG LANDFILL
LANDFILL GAS MIGRATION CONTROL
WORK PLAN

CLIENT
COUNTY OF SONOMA
TRANSPORTATION & PUBLIC WORKS

SCS ENGINEERS
STEARNS, CONRAD AND SCHMIDT
CONSULTING ENGINEERS AND CONTRACTORS
3117 FIVE CORNER, SUITE 108
SACRAMENTO, CA 95827
PH. (916) 361-1297 FAX. (916) 361-1299

PROJ. NO. 07215049.00 T2
DRAWN BY: MJE
CHECK BY: AAM
APP. BY: AAM

CADD FILE:
FIG-5 TYP.VZ.WELL030718

DATE:
03-05-18

SCALE:
AS SHOWN

FIGURE:
5



County of Sonoma Agenda Item Summary Report

Clerk of the Board
575 Administration Drive
Santa Rosa, CA 95403

Agenda Item Number: 36
(This Section for use by Clerk of the Board Only.)

To: Board of Supervisors

Board Agenda Date: November 13, 2018

Vote Requirement: Majority

Department or Agency Name(s): Board of Supervisors

Staff Name and Phone Number:

James Gore (707) 565-2241

Supervisorial District(s):

Fourth District

Title: Reappointment

Recommended Actions:

Reappoint Dane H. Petersen, Edmund Stewart, and Tatsuo Okaya to the Geyserville Fire Protection District Board of Directors for a four year term beginning December 7, 2018 and expiring December 2, 2022.

Executive Summary:

Discussion:

Prior Board Actions:

December 2, 2016

Strategic Plan Alignment Goal 4: Civic Services and Engagement

Fiscal Summary			
Expenditures	FY 17-18 Adopted	FY 18-19 Projected	FY 19-20 Projected
Budgeted Expenses			
Additional Appropriation Requested			
Total Expenditures			
Funding Sources			
General Fund/WA GF			
State/Federal			
Fees/Other			
Use of Fund Balance			
Contingencies			
Total Sources			
Narrative Explanation of Fiscal Impacts:			
Staffing Impacts			
Position Title (Payroll Classification)	Monthly Salary Range (A – I Step)	Additions (Number)	Deletions (Number)
Narrative Explanation of Staffing Impacts (If Required):			
Attachments:			
Related Items "On File" with the Clerk of the Board:			



County of Sonoma Agenda Item Summary Report

Clerk of the Board
575 Administration Drive
Santa Rosa, CA 95403

Agenda Item Number: 37
(This Section for use by Clerk of the Board Only.)

To: Board of Supervisors

Board Agenda Date: November 13, 2018

Vote Requirement: Majority

Department or Agency Name(s): Board of Supervisors

Staff Name and Phone Number:

Board of Supervisors 707-565-2241

Supervisorial District(s):

Countywide

Title: Appointment - 4 year term

Recommended Actions:

Approve the re-appointment of Bruce Abelli-Amen, Jennifer Kuszmar, John J. Nagle, Walter J. Ryan, Jr. to the Sonoma Resource Conservation District Board for a four year term beginning December 7, 2018 and ending December 7, 2022 (Countywide).

Executive Summary:

Re-appoint Bruce Abelli-Amen, Jennifer Kuszmar, John J. Nagle, and Walter J. Ryan, Jr. to the Sonoma Resource Conservation District Board.

Discussion:

Prior Board Actions:

Previously appointed on 01-05-2016

Strategic Plan Alignment Goal 4: Civic Services and Engagement

Fiscal Summary			
Expenditures	FY 18-19 Adopted	FY 19-20 Projected	FY 20-21 Projected
Budgeted Expenses			
Additional Appropriation Requested			
Total Expenditures			
Funding Sources			
General Fund/WA GF			
State/Federal			
Fees/Other			
Use of Fund Balance			
Contingencies			
Total Sources			
Narrative Explanation of Fiscal Impacts:			
Staffing Impacts			
Position Title (Payroll Classification)	Monthly Salary Range (A – I Step)	Additions (Number)	Deletions (Number)
Narrative Explanation of Staffing Impacts (If Required):			
None.			
Attachments:			
None.			
Related Items “On File” with the Clerk of the Board:			
None.			



County of Sonoma Agenda Item Summary Report

Clerk of the Board
575 Administration Drive
Santa Rosa, CA 95403

Agenda Item Number: 38
(This Section for use by Clerk of the Board Only.)

To: Board of Supervisors

Board Agenda Date: November 13, 2018

Vote Requirement: Majority

Department or Agency Name(s): Board of Supervisors

Staff Name and Phone Number:

Supervisor Lynda Hopkins 565-2241

Supervisorial District(s):

Countywide

Title: Re-appointment

Recommended Actions:

Approve the re-appointments of Melvin J. Sanchietti and Torrey Olson to the Gold Ridge Resource Conservation District Board for a four year term beginning December 7, 2018 and ending December 7, 2022. (Countywide)

Executive Summary:

Re-appoint Melvin J. Sanchietti and Torrey Olson to the Gold Ridge Resource conservation District Board.

Discussion:

Prior Board Actions:

Previously appointed on 01-05-2016

Strategic Plan Alignment Goal 4: Civic Services and Engagement

Fiscal Summary			
Expenditures	FY 18-19 Adopted	FY 19-20 Projected	FY 20-21 Projected
Budgeted Expenses			
Additional Appropriation Requested			
Total Expenditures			
Funding Sources			
General Fund/WA GF			
State/Federal			
Fees/Other			
Use of Fund Balance			
Contingencies			
Total Sources			
Narrative Explanation of Fiscal Impacts:			
Staffing Impacts			
Position Title (Payroll Classification)	Monthly Salary Range (A – I Step)	Additions (Number)	Deletions (Number)
Narrative Explanation of Staffing Impacts (If Required):			
None.			
Attachments:			
None.			
Related Items "On File" with the Clerk of the Board:			
None.			



County of Sonoma Agenda Item Summary Report

Clerk of the Board
575 Administration Drive
Santa Rosa, CA 95403

Agenda Item Number: 39
(This Section for use by Clerk of the Board Only.)

To: Board of Supervisors

Board Agenda Date: November 13, 2018

Vote Requirement: Majority

Department or Agency Name(s): Board of Supervisors

Staff Name and Phone Number:

Supervisor Lynda Hopkins 565-2241

Supervisorial District(s):

Fifth District

Title: Re-appointment

Recommended Actions:

Approve the re-appointment of Jason C. Weaver to the Russian River Fire Protection District Board for a two-year term beginning December 7, 2018 and ending December 7, 2020. (Fifth District)

Executive Summary:

Reappoint Jason C. Weaver to the Russian River Fire Protection District Board.

Discussion:

Prior Board Actions:

2016

Strategic Plan Alignment Goal 4: Civic Services and Engagement

Fiscal Summary			
Expenditures	FY 18-19 Adopted	FY 19-20 Projected	FY 20-21 Projected
Budgeted Expenses			
Additional Appropriation Requested			
Total Expenditures			
Funding Sources			
General Fund/WA GF			
State/Federal			
Fees/Other			
Use of Fund Balance			
Contingencies			
Total Sources			
Narrative Explanation of Fiscal Impacts:			
Staffing Impacts			
Position Title (Payroll Classification)	Monthly Salary Range (A – I Step)	Additions (Number)	Deletions (Number)
Narrative Explanation of Staffing Impacts (If Required):			
None.			
Attachments:			
None.			
Related Items "On File" with the Clerk of the Board:			
None.			



County of Sonoma Agenda Item Summary Report

Clerk of the Board
575 Administration Drive
Santa Rosa, CA 95403

Agenda Item Number: 40
(This Section for use by Clerk of the Board Only.)

To: Board of Supervisors of Sonoma County

Board Agenda Date: November 13, 2018

Vote Requirement: Majority

Department or Agency Name(s): Department of Health Services

Staff Name and Phone Number:

Angie Dillon-Shore, 565-6627

Supervisorial District(s):

Title: First 5 Sonoma County Commission Reappointments

Recommended Actions:

Approve the reappointment of Socorro Shiels and Michele Rogers, PhD to the First 5 Sonoma County Commission for the three-year term of December 1, 2018 through November 30, 2021.

Executive Summary:

This item requests that the Board of Supervisors approve the reappointment of two members to the First 5 Sonoma County Commission. The First 5 Sonoma County Commission recommends the reappointment of Socorro Shiels to represent local school districts and Michele Rogers, PhD to represent educators specializing in early childhood development.

Discussion:

The California Children and Families First Act of 1998 provided for the creation of a Sonoma County Children and Families Commission, now called the First 5 Sonoma County Commission, charged with promoting, supporting, and improving the early development of children from the prenatal stage through five years of age. The Commission is funded by a state surtax on tobacco products.

The First 5 Sonoma County Commission includes nine commissioners from the following categories identified in the Children and Families Act of 1998, Health and Safety Section Code 130140. Prospective members are recruited by category, not by supervisorial district.

Three (3) ex officio members:

- The Health and Human Services liaison member of the Board of Supervisors, appointed from time to time by the Chair of the Board
- The Director of the Sonoma County Health Services Department
- The Director of the Sonoma County Human Services Department

Six (6) other members from the following categories:

- Recipients of project services included in the County strategic plan

- Educators specializing in early childhood development
- Representatives of a local child care resource or referral agency or a local child care coordinating group
- Representatives of a local organization for prevention or early intervention for families at risk
- Representatives of community-based organizations that have the goal of promoting nurturing and early childhood development
- Representatives of local school districts
- Representatives of local medical, pediatric, or obstetric associations or societies

Commissioner Socorro Shiels, representing local school districts, has been a First 5 Sonoma County Commissioner since January 27, 2014 when she was appointed to fill a term which expired on November 30, 2015. She was re-appointed to serve a second term which expires on November 30, 2018. At the October 22, 2018 First 5 Sonoma County Commission meeting, the Commission recommended the reappointment of Socorro Shiels.

Commissioner Michele Rogers, PhD, representing educators specializing in early childhood development, has been a First 5 Sonoma County Commissioner since December 1, 2017 when she was appointed to fill a term which expired on November 30, 2018. At the October 22, 2018 First 5 Sonoma County Commission meeting, the Commission recommended the reappointment of Michele Rogers.

Consistent with Ordinance 5807 and the First 5 Sonoma County Commission bylaws, First 5 Sonoma County Commissioners may serve up to three consecutive terms.

First 5 Sonoma County Commission Membership

Representation Category	Name	Term Expiration
Ex-officio Member - Health & Social Services liaison member of the Board of Supervisors	Supervisor Lynda Hopkins	N/A
Ex-officio Member - Director of Health Services	Barbie Robinson	N/A
Ex-officio Member - Director of Human Services	Karen Fies	N/A
Educators specializing in early childhood development	Michele Rogers	11/30/2021 (pending approval)
Local school districts	Socorro Shiels	11/30/2021 (pending approval)
Community-based organizations that have the goal of promoting nurturing and early childhood development	Cynthia Murray	11/30/2019
Recipients of project services included in the County strategic plan	Kelly Bass Seibel	11/30/2019
Local medical, pediatric, or obstetric associations or societies	Jeff Miller, M.D.	11/30/2020
Local organization for prevention or early intervention for families at risk	Jennielynn Holmes	11/30/2020

Prior Board Actions:

On September 19, 2017 the Board approved the appointment/reappointment of Jeff Miller, M.D., Michele Rogers, PhD, and Jennielynn Holmes to the First 5 Sonoma County Commission.

Strategic Plan Alignment Goal 4: Civic Services and Engagement			
Recruitment of public members to the Commission encourages engagement with civic services and promotes a better community.			
Fiscal Summary			
Expenditures	FY 18-19 Adopted	FY 19-20 Projected	FY 20-21 Projected
Budgeted Expenses			
Additional Appropriation Requested			
Total Expenditures	0	0	0
Funding Sources			
General Fund/WA GF			
State/Federal			
Fees/Other			
Use of Fund Balance			
Contingencies			
Total Sources	0	0	0
Narrative Explanation of Fiscal Impacts:			
There are no fiscal impacts associated with this item.			
Staffing Impacts			
Position Title (Payroll Classification)	Monthly Salary Range (A – I Step)	Additions (Number)	Deletions (Number)
Narrative Explanation of Staffing Impacts (If Required):			
N/A			
Attachments:			
None			
Related Items “On File” with the Clerk of the Board:			
None			



County of Sonoma Agenda Item Summary Report

Clerk of the Board
575 Administration Drive
Santa Rosa, CA 95403

Agenda Item Number: 41
(This Section for use by Clerk of the Board Only.)

To: Sonoma County Board of Supervisors

Board Agenda Date: November 13, 2018

Vote Requirement: Majority

Department or Agency Name(s): Human Services – Sonoma County Office of Education

Staff Name and Phone Number:

Susy Marron 524-2639
Karen Fies 565-6990

Supervisorial District(s):

All

Title: Child Care Planning Council of Sonoma County Member Appointment

Recommended Actions:

Approve the appointment of Stella Gonzalez to the Child Care Planning Council of Sonoma County, as a Child Care Consumer Representative, for a two-year term beginning November 13, 2018, ending December 31, 2020.

Executive Summary:

The mission of the Child Care Planning Council (CCPC) of Sonoma County is to convene and inspire the community through collaboration, leadership, and advocacy to promote and plan for quality child care and development services for the benefit of all children (primarily birth to 12), their families, and Sonoma County.

The primary activities of the CCPC are to conduct a local child care needs assessment, develop a countywide child care plan, establish local funding priorities for child care, and to enhance collaboration and partnerships in the child care community. In accordance with AB 2141, the Board of Supervisors, and the County Superintendent of Schools are required to jointly appoint members to the local child care planning council.

Discussion:

In accordance with AB 2141, the Board of Supervisors and the County Superintendent of Schools are required to jointly appoint members to the local child care planning council in 5 categories of membership: 1) Consumers, 2) Child Care Providers, 3) Public Agency Representatives, 4) Community Representatives, and 5) Discretionary Appointees of the Board of Supervisors and the Superintendent of Schools. The Child Care Planning Council bylaws allow up to 35 members. There are currently 21 members.

The Board of Supervisors is requested to appoint the following member Stella Gonzalez, Boys & Girls Club of Center Sonoma, Child Care Consumer Representative Seat. This appointment recommendation

has been made and approved by the County Superintendent of Schools on October 5, 2018. The Council will have 13 openings for additional members after this appointment is approved.

The CCPC Membership Committee is focused on expanding membership. The Child Care Planning Council makes every effort to assure that the ethnic, racial and geographic composition is reflective of the county. Openings are posted on the Child Care Planning Council website and the County Boards and Commissions website. Additionally, community recruitment efforts are made on an ongoing basis via press releases, flyers and individual targeted outreach. Members are appointed for two-year terms with half of the members' terms expiring each year.

The Child Care Planning Council was originally established in 1992 to meet the requirements mandated by the passage of Assembly Bill (AB) 2141 to identify local priorities for child care and state preschool expansion funds. The passage of AB 1542 in 1998 connected CalWORKs, and the Sonoma County Human Services Department, to the Child Care Planning Council. On September 29, 1998, the County Superintendent of Schools and the Board of Supervisors designated the Child Care Planning Council of Sonoma County as a county commission. The Child Care Planning Council is staffed by the Sonoma County Office of Education.

Prior Board Actions:

- June 5, 2018:** Appoint Renee Whitlock-Hemsouvanh to the Child Care Planning Council of Sonoma County and requested authorization for the Director of Human Services to sign the required Certification.
- December 12, 2017:** Appoint/reappoint members of the Child Care Planning Council of Sonoma County and requested authorization for the Director of Human Services to sign the required Certification.
- September 19, 2017:** Appoint/move members of the Child Care Planning Council of Sonoma County.
- February 7, 2017:** Reappoint members of the Child Care Planning Council of Sonoma County and requested authorization for the Director of Human Services to sign the required Certification Statement regarding composition of Local Planning Council membership.
- November 15, 2016:** Appoint member to the Child Care Planning Council of Sonoma County
- November 15, 2016:** Accept Comprehensive 2016-2021 Child Care Plan
- September 13, 2016:** Appoint/move members of the Child Care Planning Council of Sonoma County.
- January 5, 2016:** Appoint/reappoint members of the Child Care Planning Council of Sonoma County and approved by-laws which established term of membership.

Strategic Plan Alignment Goal 1: Safe, Healthy, and Caring Community

The mission of the Child Care Planning Council of Sonoma County is to convene and inspire the community through collaboration, leadership and advocacy to promote and plan for quality child care and development for the benefit of all children (primarily birth to 12), their families and Sonoma County.

Fiscal Summary			
Expenditures	FY 18-19 Adopted	FY 19-20 Projected	FY 20-21 Projected
Budgeted Expenses			
Additional Appropriation Requested			
Total Expenditures	0	0	0
Funding Sources			
General Fund/WA GF			
State/Federal			
Fees/Other			
Use of Fund Balance			
Contingencies			
Total Sources	0	0	0
Narrative Explanation of Fiscal Impacts:			
There are no fiscal impacts associated with this action.			
Staffing Impacts			
Position Title (Payroll Classification)	Monthly Salary Range (A – I Step)	Additions (Number)	Deletions (Number)
Narrative Explanation of Staffing Impacts (If Required):			
None			
Attachments:			
None			
Related Items "On File" with the Clerk of the Board:			
None			



County of Sonoma Agenda Item Summary Report

Clerk of the Board
575 Administration Drive
Santa Rosa, CA 95403

Agenda Item Number: 42
(This Section for use by Clerk of the Board Only.)

To: Board of Supervisors

Board Agenda Date: November 13, 2018

Vote Requirement: Majority

Department or Agency Name(s):

Staff Name and Phone Number:

James Gore, (707) 565-2241

Supervisorial District(s):

Fourth District

Title: Certificates

Recommended Actions:

Present a check along with Board Members of the "Sonoma County Children's Charities-The Schulz" to be split evenly among the following non-profit partners who benefitted from the Schulz Celebrity Golf Tournament:

- PDI Surgery Center
- Boys and Girls Club of Central Sonoma County
- Santa Rosa Catholic Charities Family Support Center
- Sonoma Academy Scholarship Fund
- Charles M. Schulz Museum Children's programs
- The First Tee North Coast

Certificates of Honor will be given at a later date to the generous sponsors of the Schulz Celebrity Golf Classic held on June 5, 2018, raising over \$1,000,000 to benefit Sonoma County Children's Charities:

- Lytton Rancheria - Grand Sponsor
- Poppy Bank
- Jackson Family Wines
- Draxton Wines
- Amaturo Family of Companies
- Northern California Medical Associates
- Codding Foundation
- Trione Vineyards and Winery
- American Agcredit
- Sonoma Jet Center
- Coppola Winery
- Rodney Strong
- ER Sawyer Jewelers

Press Democrat/Sonoma Media
Vintners Inn

Supervisor Gore's office will be responsible for creating the certificates that will be given at a later time.

Executive Summary:

Discussion:

Prior Board Actions:

Board recognizes sponsors of the Schulz Celebrity Golf Classic every fall.

Strategic Plan Alignment Goal 3: Invest in the Future

Fiscal Summary

Expenditures	FY 16-17 Adopted	FY 17-18 Projected	FY 18-19 Projected
Budgeted Expenses			
Additional Appropriation Requested			
Total Expenditures			
Funding Sources			
General Fund/WA GF			
State/Federal			
Fees/Other			
Use of Fund Balance			
Contingencies			
Total Sources			

Narrative Explanation of Fiscal Impacts:

Staffing Impacts			
Position Title (Payroll Classification)	Monthly Salary Range (A – I Step)	Additions (Number)	Deletions (Number)
Narrative Explanation of Staffing Impacts (If Required):			
Attachments:			
Related Items “On File” with the Clerk of the Board:			



County of Sonoma Agenda Item Summary Report

Clerk of the Board
575 Administration Drive
Santa Rosa, CA 95403

Agenda Item Number: 43
(This Section for use by Clerk of the Board Only.)

To: Board of Supervisors of Sonoma County

Board Agenda Date: November 13, 2018

Vote Requirement: Majority

Department or Agency Name(s): Department of Health Services

Staff Name and Phone Number:

Barbie Robinson, 565-7876

Supervisorial District(s):

Title: World AIDS Day 2018

Recommended Actions:

Adopt a resolution proclaiming December 1, 2018 as World AIDS Day in Sonoma County.

Executive Summary:

The Department of Health Services requests the Sonoma County Board of Supervisors to proclaim December 1, 2018 as World AIDS Day in Sonoma County.

Discussion:

The World Health Organization established World AIDS Day in 1988 to focus attention on the devastating impact of the HIV/AIDS epidemic and to provide an opportunity for government, local agencies, community groups, associations, and individuals to demonstrate the importance of the fight against HIV/AIDS.

The HIV Service Providers Coalition of HIV prevention and care agencies are planning a number of events during the week surrounding World AIDS Day. These events are designed to increase awareness and understanding of human immunodeficiency virus infection (HIV) and acquired immune deficiency syndrome (AIDS), to promote testing for HIV and to encourage Sonoma County residents to get involved locally and globally by volunteering at or donating to one of the many local HIV prevention and care agencies in Sonoma County. This year's theme, which marks the 30th anniversary of World AIDS Day, is "Know Your Status." Several local events scheduled for World AIDS Day are listed later in this report.

Statistics regarding HIV/AIDS globally, country-wide, state-wide, and county-wide are provided below to inform the reader and reinforce the importance of the fight against HIV/AIDS.

Global HIV/AIDS Statistics in 2017 (Source: WHO, UNAIDS)

- 36.9 million people globally were living with HIV.
- 19.5 million people were accessing antiretroviral therapy.
- An estimated 1.8 million people were newly infected with HIV.

- 940,000 people died from AIDS related illnesses.
- 35.4 million people have died from AIDS-related illnesses since the start of the epidemic.

United States HIV/AIDS Statistics for 2015 (Source: CDC)

- An estimated 38,500 persons were diagnosed with HIV infection.
- More than 1.1 million people are living with HIV/AIDS.
- Nearly 1 in 7 people living with HIV (15%) are not aware of their status.
- 18,303 people received an AIDS diagnosis.

California HIV/AIDS Statistics in 2016 (Source: CDPH)

- 5,061 people received a new diagnosis of HIV infection.
- Approximately 132,405 persons are living with HIV infection.

Sonoma County HIV/AIDS Statistics in 2017 (Source: CDPH, eHARS)

- 33 people received a new diagnosis of HIV infection.
- 5 received a simultaneous diagnosis of HIV infection and AIDS.
- Approximately 1,600 persons are living with HIV infection.

After a period of stability, it appears that the number of newly diagnosed HIV cases in Sonoma County is declining. However, this decline is not consistent across demographic categories. New cases are decreasing in men and in white individuals. The number of female and Hispanic/Latino cases are stable. Newly diagnosed persons with HIV infection or AIDS reside throughout the county. The majority of persons currently living with HIV or AIDS in Sonoma County are white males. The number of newly diagnosed AIDS cases continues to decline, primarily a result of effective treatment.

Beyond these statistics is the truth that HIV/AIDS touches all of us. We all have a loved one, a friend, or a colleague who is HIV positive. And all of us are potentially at risk for contracting HIV. World AIDS Day reminds us and encourages us to support awareness of HIV/AIDS including awareness of our own HIV status, and to support efforts to decrease stigma, to improve HIV prevention and to improve care for those already infected.

New prevention efforts for those at highest risk for contracting HIV are being adopted. These efforts include education for health care providers about pre-exposure prophylaxis (PrEP) which is supported by the Centers for Disease Control, the California Department of Public Health and many other public health organizations. We want clinicians to encourage people at highest risk for HIV to talk to their health care providers about pre-exposure prophylaxis. Pre-exposure prophylaxis, comprised of one pill once per day, significantly decreases the risk of contracting the HIV virus if an individual is exposed.

Every year there is a theme for World AIDS Day. This year is "Know Your Status." Everyone between the ages of 13 and 65 is encouraged to be tested at least once and those at higher risk to test much more often. Everyone should be tested and know their HIV status.

On December 1st, communities throughout the world commemorate those who have passed on, acknowledge the presence and risk of HIV/AIDS in their own lives, honor the work of those who strive to increase HIV/AIDS awareness, and commit to supporting efforts to care for HIV infected individuals and to halt new HIV infections.

The Department of Health Services and the HIV Service Providers Coalition are dedicated to HIV prevention and care in Sonoma County. These organizations and others are on a journey towards our

ambitious goal of “Know your Status, Getting to Zero, and Achieving an AIDS-free Generation.” Proclaiming December 1, 2018 as World AIDS Day in Sonoma County provides important support and encourages others to join our effort.

Local World AIDS Day Events for 2018

Event Name: Dine Out For Life

Where: Participating Sonoma County Restaurants

When: Thursday, November 29, 2018

More Info: 25% to 50% of sales will go to Food For Thought. Food for Thought distributes healthy food and meals to chronically ill HIV patients.

Event Name: Give Back Tuesday

Where: Rainbow Cattle Company in Guerneville

When: Tuesday, December 4, 2018; beginning at 6:00 P.M.

More Info: Raffle prizes and 20% of sales of drinks for the evening go to benefit the Sonoma County AIDS Emergency Fund. Funds help those diagnosed with HIV who have emergency expenses that are not covered by any other funding source.

Event Name: HIV and Hepatitis C Testing

Where: Sonoma State University Health Center

When: Tuesday, December 4, 2018

More Info: Face to Face will provide HIV and Hepatitis C testing services.

Prior Board Actions:

For several years past, the Board has adopted resolutions proclaiming December 1st as World AIDS Day in Sonoma County, most recently on November 15, 2016.

Strategic Plan Alignment Goal 1: Safe, Healthy, and Caring Community

Recognizing this day as a memorial for all who have died of HIV/AIDS in Sonoma County and a time to honor those who work with and care for HIV clients and those who strive to prevent future HIV infections supports HIV/AIDS prevention, stigma reduction, and improved care of HIV infected individuals.

Fiscal Summary			
Expenditures	FY 18-19 Adopted	FY 19-20 Projected	FY 20-21 Projected
Budgeted Expenses			
Additional Appropriation Requested			
Total Expenditures	0	0	0
Funding Sources			
General Fund/WA GF			
State/Federal			
Fees/Other			
Use of Fund Balance			
Contingencies			
Total Sources	0	0	0
Narrative Explanation of Fiscal Impacts:			
There are no fiscal impacts associated with this item.			
Staffing Impacts			
Position Title (Payroll Classification)	Monthly Salary Range (A – I Step)	Additions (Number)	Deletions (Number)
Narrative Explanation of Staffing Impacts (If Required):			
N/A			
Attachments:			
Resolution			
Related Items "On File" with the Clerk of the Board:			
None			



County of Sonoma

State of California

Date: November 13, 2018

Item Number: _____
Resolution Number: _____

4/5 Vote Required

Resolution of the Board of Supervisors of the County of Sonoma, State of California, Recognizing December 1, 2018 as World AIDS Day in Sonoma County

Whereas, the World Health Organization established World AIDS Day in 1988 to focus attention on the devastating impact of the HIV/AIDS epidemic and to provide an opportunity for government, local agencies, community groups, associations, and individuals to demonstrate the importance of the fight against HIV/AIDS;

Whereas, on December 1st, communities throughout the world commemorate those who have passed on and honor the work of those who strive to increase HIV/AIDS awareness, reduce fear and stigma by providing accurate information, promote testing, reduce risk for HIV transmission, and improve access to treatment and care;

Whereas, the theme for World AIDS Day 2018 is "Know Your Status," chosen by the World AIDS Campaign, an international coalition of HIV and AIDS groups and networks;

Whereas, the Department of Health Services and the HIV Service Providers Coalition are dedicated to HIV prevention and care in Sonoma County and are on a journey towards the ambitious goal of "Know your Status, Getting to Zero, and Achieving an AIDS-free Generation;" and

Whereas, proclaiming December 1, 2018 as World AIDS Day in Sonoma County provides important support and encourages others to join our effort.

Now, Therefore, Be It Resolved that the Board of Supervisors of the County of Sonoma, does hereby recognize December 1, 2018 as World AIDS Day in Sonoma County.

Supervisors:

Gorin:

Rabbitt:

Zane:

Hopkins:

Gore:

Ayes:

Noes:

Absent:

Abstain:

So Ordered.



County of Sonoma
Agenda Item
Summary Report

Clerk of the Board
575 Administration Drive
Santa Rosa, CA 95403

Agenda Item Number: 44
(This Section for use by Clerk of the Board Only.)

To: Board of Supervisors

Board Agenda Date: September 18, 2018

Vote Requirement: Majority

Department or Agency Name(s): Board of Supervisors

Staff Name and Phone Number:

Supervisor James Gore 565-2241

Supervisorial District(s):

Fourth

Title: Gold Resolution

Recommended Actions:

Approve Gold Resolution declaring November 26 through November 30, 2018 as California Clerk of the Board of Supervisors Week.

Executive Summary:

Prior Board Actions:

09/17/2018

Strategic Plan Alignment

Fiscal Summary - FY 16-17

Expenditures		Funding Source(s)	
Budgeted Amount	\$		\$
Add Appropriations Req'd.	\$	State/Federal	\$
	\$	Fees/Other	\$
	\$	Use of Fund Balance	\$
	\$	Contingencies	\$
	\$		\$
Total Expenditure	\$	Total Sources	\$

Narrative Explanation of Fiscal Impacts (If Required):			
Staffing Impacts			
Position Title (Payroll Classification)	Monthly Salary Range (A – I Step)	Additions (Number)	Deletions (Number)
Narrative Explanation of Staffing Impacts (If Required):			
Attachments:			
Gold Resolution to be presented offsite in December.			
Related Items “On File” with the Clerk of the Board:			

Date: November 13, 2018

Item Number: _____
Resolution Number: _____

4/5 Vote Required

**Resolution of the Board of Supervisors Recognizing November 26 Through November 30,
2018 As California Clerk Of The Board Of Supervisors Week**

Whereas, California counties provide many services that are essential to the lives of Californians; and

Whereas, the position of the Clerk of the Board of Supervisors plays an integral role in the function of California County government; and

Whereas, the Clerk of the Board performs many legally mandated functions that protect and preserve the rights of citizens to an open and accessible government; and

Whereas, the work performed by Clerks of the Board is a time honored and vital part of local government; and

Whereas, the Clerks' duties of record keeping is revered, their work among the earliest recorded on behalf of the public, and Clerks have long pledged to maintain their neutrality and impartiality of the proceedings of government; and

Whereas, the California Clerk of the Board of Supervisors Association, an affiliate of the California State Association of Counties, is organized to promote the principles of good government, to represent the interests of Clerks of the Board with legislative bodies and other professional organizations, to encourage the development of professional growth and education, and to support the objectives of all regional groups established within the Association; and

Whereas, it is most appropriate that we recognize the accomplishments of Clerks of the Board across the 58 counties in the State of California.

Now, Therefore, Be It Resolved that the Board of Supervisors of Sonoma County does hereby designate the week of November 26 through November 30, 2018 as "California Clerk of the Board of Supervisors Week" in recognition of the high level of services bestowed upon the

Resolution #

Date:

Page 2

people of the County of Sonoma and the people of California by Clerks of the Board.

Supervisors:

Gorin:

Rabbitt:

Gore:

Hopkins:

Zane:

Ayes:

Noes:

Absent:

Abstain:

So Ordered.



County of Sonoma Agenda Item Summary Report

Clerk of the Board
575 Administration Drive
Santa Rosa, CA 95403

Agenda Item Number: 45
(This Section for use by Clerk of the Board Only.)

To: Board of Supervisors

Board Agenda Date: November 13, 2018

Vote Requirement: Majority

Department or Agency Name(s): Board of Supervisors

Staff Name and Phone Number:

Supervisor David Rabbitt 565-2241

Supervisorial District(s):

Second District

Title: Gold Resolution

Recommended Actions:

Adopt a resolution of the Board of Supervisors honoring and commending John C. Brown on the occasion of his retirement as Petaluma City Manager and his 35 years of public service. (Second District)

Executive Summary:

John C. Brown is retiring as the City Manager of Petaluma, California after ten years of service. In addition to his tenure at the City of Petaluma, Mr. Brown has served over 35 years in public service for the counties of Yuba and Ventura, California and the cities of Jackson and Oxnard, California and Woodburn, Oregon.

Discussion:

N/A

Prior Board Actions:

N/A

Strategic Plan Alignment Goal 1: Safe, Healthy, and Caring Community

Fiscal Summary			
Expenditures	FY 16-17 Adopted	FY 17-18 Projected	FY 18-19 Projected
Budgeted Expenses			
Additional Appropriation Requested			
Total Expenditures			
Funding Sources			
General Fund/WA GF			
State/Federal			
Fees/Other			
Use of Fund Balance			
Contingencies			
Total Sources			
Narrative Explanation of Fiscal Impacts:			
Staffing Impacts			
Position Title (Payroll Classification)	Monthly Salary Range (A – I Step)	Additions (Number)	Deletions (Number)
Narrative Explanation of Staffing Impacts (If Required):			
N/A			
Attachments:			
Gold Resolution.			
Related Items "On File" with the Clerk of the Board:			



County of Sonoma

State of California

Date: November 13, 2018

Item Number: _____
Resolution Number: _____

4/5 Vote Required

**Resolution of the Board of Supervisors of the County of Sonoma, State of California,
Honoring and Commending John C. Brown on the Occasion of his Retirement as
Petaluma City Manager and 35 Years of Public Service**

Whereas, John C. Brown has served the community of Petaluma for ten years as City Manager providing strong and capable leadership through economic downturns, paving the way to build local business, housing and public infrastructure, and developing a strong leadership team to implement community services for the residents of Petaluma; and,

Whereas, Mr. Brown is retiring after thirty-five years in public service which, along with his tenure as Petaluma City Manager, includes serving as: City Administrator in Woodburn, Oregon, City Manager in Jackson, California, County Administrator in Yuba County, California, and early in his public service career financial and management analyst work for the County of Ventura and the City of Oxnard; and,

Whereas, Mr. Brown, a Southern California native, comes from a family with a strong commitment to public service, including educator, school administration and deputy agency head. Mr. Brown graduated with a Bachelor's Degree in Political Science from the University of California in 1980 at Santa Barbara and a Master's in Public Administration from California State University Northridge in 1987, where he graduated with distinction; and,

Whereas, Mr. Brown, using his strengths as a communicator, facilitator, and strategic planner, has been committed to inclusivity and built best practices and strong working relationships to increase the Hispanic and broader community's trust and access to government services; and,

Whereas, Mr. Brown, in the last 35 years of his public service, has delivered balanced budgets, fostered economic growth, built fund reserves, launched environmentally sound projects, increased funding to anti-poverty programs, expanded County park systems, supported the growth of local business, improved infrastructure, built strong leadership, and increased customer service, trust and access to government services for

Resolution #

Date: November 13, 2018

Page 2

residents; and,

Now, Therefore, Be It Resolved that the Board of Supervisors of the County of Sonoma recognize and honor John C. Brown on the occasion of his retirement from the City of Petaluma and his 35 years of public service.

Supervisors:

Gorin:

Rabbitt:

Zane:

Hopkins:

Gore:

Ayes:

Noes:

Absent:

Abstain:

So Ordered.



County of Sonoma Agenda Item Summary Report

Clerk of the Board
575 Administration Drive
Santa Rosa, CA 95403

Agenda Item Number: 46
(This Section for use by Clerk of the Board Only.)

To: Board of Directors of Sonoma County Water Agency

Board Agenda Date: November 13, 2018

Vote Requirement: Majority

Department or Agency Name(s): Sonoma County Water Agency

Staff Name and Phone Number:

David Royall (707)521-1892

Supervisorial District(s):

Title: Sonoma County Water Agency Appointment of Retiree Extra-Help

Recommended Actions:

Pursuant to Government Code §7522.56 approve the appointment of Susan Keach as an Environmental Compliance Inspector Retiree Extra-Help, in order to fill a critically needed position within 180 days of her retirement, with an appointment date as early as November 13, 2018.

Executive Summary:

Pursuant to the California Public Employees' Pension Reform Act (Pension Reform Act), Government Code §7522.56, an exception can be made to reappoint a retiree as extra-help provided the governing body certifies that the appointment is necessary to fill a critically needed position, in those circumstances where 180 days from the date of retirement has not yet passed. This approval must be in a noticed public meeting and not on a consent calendar. The Pension Reform Act includes other requirements in order for a retiree to be eligible for an Extra-Help appointment, such as not having accepted a retirement incentive and not having accepted unemployment arising out of prior public appointment. The individual and delegated agency staff have completed the Retiree Extra-Help Compliance Form certifying the appropriateness of the appointment.

Discussion:

Susan Keach, Environmental Compliance Inspector, retired on October 23, 2018. She entered Sonoma County Water Agency (Sonoma Water) service on February 11, 2003 as an Environmental Compliance Inspector Extra-Help and became a permanent employee in the classification of Environmental Compliance Inspector on February 8, 2011. At the time of her retirement, Ms. Keach performed the following functions for Sonoma Water:

- Development of Commercial/Industrial Waste Water Permits and Discharge Permits
- Commercial/Industrial User Waste Water Sampling and Inspections
- Commercial/Industrial User Project Plan Review and Survey Evaluation
- Site Visit follow-up on Illegal Discharges

- Correspondence with Commercial/Industrial users and Permit Sonoma
- County Safe Medicine Program Implementation and Tracking

Existing staff in the section includes two Environmental Compliance Inspectors and one Environmental Compliance Technician. Beginning in November or early December, one Environmental Compliance Inspector will be taking family bonding leave. Additionally, at the same time, the Environmental Compliance Technician will be leaving Sonoma Water to pursue an opportunity with the Coast Guard in an Officer Training program. The Environmental Compliance section has a need for Ms. Keach’s skills and experience to help train new staff as well as continue critical operations in the section.

This position is currently vacant and will be recruited as it is an ongoing critical need for Sonoma Water’s Environmental Services Section.

Sonoma Water has consulted with the Human Resources Department which is supportive of the recommended action.

In accordance with Government Code section 7522.56, Sonoma Water is asking the Board to certify as follows:

- Susan Keach’s appointment to Environmental Compliance Inspector, Retiree Extra-Help is necessary to fill a critically needed position within 180 days of her retirement date;
- Susan Keach did not accept retirement incentives upon her retirement; and
- Susan Keach’s appointment shall not exceed 960 hours per year.
- Per Internal Revenue Code section 401(a)(36), Susan Keach meets the requirement of being of normal retirement age.

If the Board of Directors makes the foregoing certifications, Susan Keach will be hired as of November 13, 2018 as Environmental Compliance Inspector, Retiree Extra-Help.

Prior Board Actions:

None.

Strategic Plan Alignment Goal 4: Civic Services and Engagement

The Water Agency Strategic Plan: Organizational Goal 1; Increase organizational efficiency, effectiveness, and resilience to natural disasters. The position will fill a critical operational need for Sonoma Water.

Fiscal Summary			
Expenditures	FY 18-19 Adopted	FY 19-20 Projected	FY 20-21 Projected
Budgeted Expenses	\$30,400		
Additional Appropriation Requested			
Total Expenditures	\$30,400		
Funding Sources			
General Fund/WA GF	\$30,400		
State/Federal			
Fees/Other			
Use of Fund Balance			
Contingencies			
Total Sources	\$30,400		
Narrative Explanation of Fiscal Impacts:			
<p>The cost of this retiree extra help position is approximately \$30,400 assuming 3 months of work or 480 hours of the 960 annual maximum pursuant to Government Code section 7522.56.</p> <p>Salary and benefits are budgeted in the General Fund which is funded through water sales revenue, taxes and grants. The General Fund is reimbursed by our enterprise funds through project costing. These increased labor costs will be funded by existing funds in Sonoma Water’s enterprise funds. Sonoma Water’s cost accounting system allocates labor costs to Water Agency projects specific to its enterprise funds.</p>			
Staffing Impacts			
Position Title (Payroll Classification)	Monthly Salary Range (A – I Step)	Additions (Number)	Deletions (Number)
Narrative Explanation of Staffing Impacts (If Required):			
This is a Retiree Extra-Help appointment; no permanent allocations are being added or changed.			
Attachments:			
None.			
Related Items “On File” with the Clerk of the Board:			
None.			



County of Sonoma Agenda Item Summary Report

Clerk of the Board
575 Administration Drive
Santa Rosa, CA 95403

Agenda Item Number: 47
(This Section for use by Clerk of the Board Only.)

To: Board of Supervisors

Board Agenda Date: November 13, 2018

Vote Requirement: Majority

Department or Agency Name(s): Permit Sonoma

Staff Name and Phone Number:

Crystal Acker 565-8357

Supervisorial District(s):

1

Title: Agricultural Preserve expansion and new Land Conservation Act contract; Steve Shaffer, Jack London Ranch, LLC; AGP17-0011

Recommended Actions:

Hold a public hearing and adopt a resolution to expand an existing Agricultural Preserve (2-457) by adding 151.24 acres and approve a new Prime Land Conservation (Williamson) Act contract and Land Conservation Plan on the same 151.24 acre parcel located at 2600 London Ranch Rd., Glen Ellen; APN 054-050-037; Permit Sonoma File No. AGP17-0011; Supervisorial District 1.

Executive Summary:

Steve Shaffer seeks approval to expand an existing Agricultural Preserve Area (2-457) and execute a new Prime Land Conservation Act contract on a 151.24 acre parcel. The subject parcel is located on Sonoma Mountain and contains 121 acres of vineyard, an agricultural employee residence, a barn, and oak woodland. The base zoning of the site is LIA (Land Intensive Agriculture) B7 (frozen lot size), with LG/MTN (Local Guidelines for the Taylor/Sonoma/Mayacamas Mountains), RC50/50 (Riparian Corridor 50-foot setback for both structural development and agricultural cultivation), SR (Scenic Resource – Scenic Landscape Unit) combining districts.

Discussion:

Background:

As part of the Board of Supervisors' December 2011 update of the Sonoma County Uniform Rules for Agricultural Preserves and Farmland Security Zones ("Uniform Rules") the Board eliminated the distinction between Prime (Type I) and Non-Prime (Type II) Agricultural Preserves. This allows the County to enter into either a Prime or Non-Prime contract in any established Preserve. The subject land is located adjacent to established Agricultural Preserve Area Number 2-457.

As part of the update of the Uniform Rules, the County has implemented use of a Land Conservation Plan which is incorporated into a Land Conservation Act Contract. The Land Conservation Plan shows

locations of various agricultural, open space, permitted, and compatible land uses on contracted land. Future changes to the Land Conservation Plan may be approved by the Director of PRMD and recorded on title of the subject parcel.

The County may consider and approve expansion of an agricultural preserve concurrently with a request for a new contract.

Proposed Project:

Steve Shaffer, for Jack London Ranch LLC, seeks approval to expand an existing Agricultural Preserve Area (2-457) and execute a new Prime Land Conservation Act contract on a 151.24 acre parcel. The subject parcel is located on the eastern slope of Sonoma Mountain, approximately one mile southwest of Glen Ellen. The parcel contains 121 acres of vineyard; 1.74 acres of accessory agricultural and compatible land uses including a 700 square foot agricultural employee residence, a 1,500 square foot barn, horse corral, and pastureland; and approximately 28.5 acres of oak woodland (Attachment A). The vineyard was originally planted between 1973 and 1985. The base zoning of the site is LIA (Land Intensive Agriculture) B7 (frozen lot size), with LG/MTN (Local Guidelines for the Taylor/Sonoma/Mayacamas Mountains), RC50/50 (Riparian Corridor 50-foot setback for both structural development and agricultural cultivation), SR (Scenic Resource – Scenic Landscape Unit) combining districts.

The proposed contract will include one Assessor Parcel Number (APN 054-050-037), which surrounds three smaller parcels not included in the contract. These parcels (APNs 054-050-038, 054-050-039 & 054-050-040) were part of a three-lot minor subdivision (MNS87-418); the subject parcel was the designated remainder of that subdivision (Attachment B).

Enlargement of the Agricultural Preserve:

The 151.24 acre subject parcel is not currently included in the existing, adjacent Agricultural Preserve. This area will be added to Agricultural Preserve Number 2-457 to ensure that the boundaries are coterminous with the contracted area (Attachment C). Under the Uniform Rules (Rule 3.2), the Board approved Agricultural Preserve areas to be unilaterally applied; therefore, a prime contract is consistent with a Type II Preserve. The parcel qualifies for inclusion in an Agricultural Preserve, and thus enlargement of the current agricultural preserve is permitted.

New Land Conservation (Williamson) Act Contract:

To be eligible for a new Prime Land Conservation Act contract, the subject parcel must be comprised of a single legal parcel at least 10 acres in size, have 50% of the total parcel dedicated to permanent crop uses, and meet the minimum income requirements of the Williamson Act. In addition, other uses of the property must be compatible with the agricultural uses and occupy collectively no more than 5 acres or 15 percent of the land, whichever is less. The subject parcel is 151.24 acres in size, and has 121 acres of land planted with premium wine grapes (Merlot, Cabernet Sauvignon, Zinfandel and Syrah) which exceeds the 50% requirement. Over the past five years, the vineyard has exceeded the minimum requirement of \$1,000.00 gross income per acre, and therefore, qualifies for a Land Conservation Contract for prime agricultural land. The structures are all agricultural or listed as compatible uses, and do not exceed 5 acres.

Staff Recommendation:

Staff recommends the Board of Supervisors approve the request because all of the state and local requirements for a Prime Land Conservation Act Contract for the 151.24 +/- acres within the expanded Agricultural Preserve have been met.

Land Conservation Act contracts assist in the preservation of agricultural land throughout Sonoma County. In exchange for retaining land in agricultural production, the landowner receives reduced property taxes.

Prior Board Actions:

None

Strategic Plan Alignment Goal 2: Economic and Environmental Stewardship

Agricultural Preserves and Land Conservation Act Contracts support agriculture and agribusiness by assisting in the preservation of agricultural land through the incentive of reduced property taxes in exchange for retaining the land in agricultural production.

Fiscal Summary

Expenditures	FY 18-19 Adopted	FY 19-20 Projected	FY 20-21 Projected
Budgeted Expenses			
Additional Appropriation Requested			
Total Expenditures			
Funding Sources			
General Fund/WA GF			
State/Federal			
Fees/Other			
Use of Fund Balance			
Contingencies			
Total Sources			

Narrative Explanation of Fiscal Impacts:

Approval of the Land Conservation Act Contract means that the owner will pay a reduced property tax assessment based upon the value of the agricultural uses rather than the land value under Proposition 13. This results in a reduction in the County's share of property tax revenue for each parcel under a Land Conservation Act Contract. The amount of this reduction for an individual contract depends on parcel-specific variables including the Proposition 13 status of the land and the value of the agricultural crop, and is determined annually by the Assessor's Office. For this particular contract, the Assessor estimates the property assessment value will be reduced by approximately \$400,000. Property taxes are generally

1.1% of assessed value. The Board approves new contracts due to the importance of the County's agricultural economy despite the reduced property tax revenue.

Staffing Impacts

Position Title (Payroll Classification)	Monthly Salary Range (A – I Step)	Additions (Number)	Deletions (Number)

Narrative Explanation of Staffing Impacts (If Required):

N/A

Attachments:

Draft Board of Supervisors Resolution
 Attachment A: Site Plan
 Attachment B: Non-Participating Parcels Map
 Attachment C: Agricultural Preserve Area Expansion Map

Related Items "On File" with the Clerk of the Board:

Land Conservation Act Contract with attached Exhibit A (legal description) and Exhibit B (Land Conservation Plan with attached Site Plan).



County of Sonoma
State of California

Date: November 13, 2018

Item Number: _____
Resolution Number: _____

AGP17-0011 Crystal Acker

4/5 Vote Required

Resolution Of The Board Of Supervisors Of The County Of Sonoma, State Of California, Approving The Request By Steve Shaffer For Jack London Ranch, LLC To (1) Expand An Existing Agricultural Preserve (2-457) By Adding 151.24+/- Acres And (2) Approve A New Prime Land Conservation Act Contract And Land Conservation Plan On The Same 151.24+/- Acre Parcel Located At 2600 London Ranch Rd., Glen Ellen; APN 054-050-037.

Whereas, a request has been made by Steve Shaffer, Lack London Ranch, LLC, to authorize the Chair of the Board of Supervisors to approve an expansion of an existing Agricultural Preserve (2-457) by adding 151.24 acres and establish a new Prime Land Conservation Act Contract and Land Conservation Plan on the same 151.24 acre parcel located at 2600 London Ranch Road, Glen Ellen; APN (054-050-037); Supervisorial District No. 1; and

Whereas, on December 13, 2011, the Board of Supervisors adopted updated Sonoma County Uniform Rules for Agricultural Preserves and Farmland Security Zones (Uniform Rules) (Resolution No. 11-0678). The Uniform Rules were last amended November 7, 2017, by Resolution 17-0438; and

Whereas, consistent with the Uniform Rules, the Land Conservation Act Contract form incorporates a Land Conservation Plan identifying the various uses of the contracted land. Future changes to identified land uses require amendment of the Land Conservation Plan. The Board, pursuant to Resolution No. 11-0678, has authorized the Director of PRMD to approve amendments to executed Land Conservation Plans; and

Whereas, the Board of Supervisors finds that the 151.24 acre parcel, is currently located adjacent to Agricultural Preserve 2-457, meets the requirements for inclusion in that preserve, and presently meets the requirements for a new Prime Land Conservation Act Contract; and

Whereas, consistent with the Uniform Rules, the Board of Supervisors may concurrently consider and approve both the enlargement of Agricultural Preserve 2-457 and the new Land Conservation Contract; and

Resolution #

Date:

Page 2

Whereas, in the Uniform Rules (Rule 3.2), there is not a distinction between the two types of preserves; thus, a prime contract is consistent with a Type II Preserve.

Whereas, the inclusion of the 151.24 acres, identified as APN 054-050-037, into Agricultural Preserve 2-457 is consistent with the Sonoma County General Plan and the applicable provisions of state law; and

Whereas, the 151.24 acre parcel will meet the requirements for a new Prime Land Conservation Act Contract, upon inclusion of the 151.24 acre parcel into the Agricultural Preserve 2-457.

Now, Therefore, Be It Resolved that the Board of Supervisors, having considered the file information, staff report, and all public comments, makes the following specific findings concerning the requirements for enlargement of Agricultural Preserve 2-457:

1. Pursuant to Government Code Section 51231 and under the County's Uniform Rules (Uniform Rule 3.5.A.) the Board of Supervisors may modify an existing Agriculture Preserve by a Resolution after a public hearing. Pursuant to Government Code Section 51237, the Resolution and enlarged Agricultural Preserve Map depicting the 151.24 acres added to the preserve area will be recorded.
2. Pursuant to Government Code Section 51234, enlargement of an Agricultural Preserve must be consistent with the General Plan. Also, the use of any land within an agricultural preserve must be restricted by zoning that is compatible with the agricultural or open space uses of the land within the preserve subject to Land Conservation contracts. Enlarging the existing Agricultural Preserve 2-457 is consistent with the General Plan because the land is devoted to agricultural use, is contiguous to an existing Agricultural Preserve, is designated Land Intensive Agriculture under the General Plan and the zoning is LIA (Land Intensive Agriculture) which restricts land to agricultural uses or compatible uses. With over 50% of the 151.24 acres used for vineyards, the parcel is deemed devoted to agriculture. The enlargement of the existing Agricultural Preserve Area does not result in any loss of land under the Land Conservation Act program since 151.24 acres is being added.
3. Generally, an Agricultural Preserve must contain at least 100 contiguous acres of land unless the Board of Supervisors finds that a smaller preserve is necessary due to the unique characteristics. Agricultural Preserve 2-457 is already larger than 100 acres. This request adds 151.24 acres to Agricultural Preserve 2-457, totaling 1,480 acres.
4. The enlargement of Agricultural Preserve 2-457 can be considered concurrently with the application for a new contract and approved by one action.
5. Pursuant to Section 15317 of the CEQA Guidelines, the project is Categorical Exempt from CEQA as an expansion of an established Agricultural Preserve and the

making of a new contract under the Williamson Act.

Be It Further Resolved that the Board of Supervisors, having considered the file information, staff report, and all public comments, makes the following specific findings concerning the requirements for a new Prime Land Conservation Act Contract ("Contract"):

- a) Land is within an Agricultural Preserve: The parcel is currently located adjacent to Agricultural Preserve 2-457. This parcel will be concurrently added to the Agricultural Preserve to ensure that the boundaries are coterminous with the contract. The Board of Supervisors may approve an application for the establishment or alteration of an agricultural preserve concurrently with its approval of an application for a contract or contracts within the preserve.
- b) Agricultural Use of the Land: In Sonoma County, this means that at least 50% of the land is used for agriculture purposes. The 151.24 acre parcel is planted in 121 acres of vineyards, which exceeds the 50% requirement to be deemed devoted to agricultural use.
- c) Single Legal Parcel Requirement: The land proposed for the contract is comprised of a single legal parcel made up of Sonoma County Assessor's Parcel Number 054-050-037.
- d) Minimum Parcel Size: The land must be at least 10 acres in size for a Prime Land Conservation Act contract. The 151.24 acre parcel exceeds the 10-acre minimum parcel size for a new Prime Land Conservation Act Contract.
- e) Minimum Income Requirement: For vineyard land, the minimum income requirement is \$1,000.00 per planted acre gross annual income. The vineyard operation has generated an average gross annual income of \$8,400 between the years of 2013 and 2017, which exceeds the minimum annual income requirements.
- f) Accessory Agricultural Uses: Accessory agricultural structures are allowed on contracted land provided they are incidental, related, and subordinate to the qualifying agricultural use. The parcel has an existing 1,500 square foot agriculturally exempt barn used to store equipment, vehicles, and other items used exclusively in the vineyard operation (permitted under AEX07-0053).
- g) Non-Agricultural Compatible Uses: Non-accessory agricultural uses and structures are considered compatible uses if enumerated in the Uniform Rules under Rule 8.3. Compatible uses must be limited to 5 acres or 15% of the total acreage, whichever is less. The parcel contains approximately 1.74 acres of compatible land uses including a 700 square foot agricultural employee residence, a horse corral, and pastureland, which is less than and therefore complies with the 5-acre maximum.

Resolution #

Date:

Page 4

h) Prime Agricultural Land: Prime Agricultural Land is defined as land planted with fruit- or nut-bearing trees, vines, bushes, or crops which have a nonbearing period of less than five years and meet the minimum income requirements. Prime land also means land that qualifies for rating as class I or class II in the National Resource Conservation Service land use capability classifications, or land that qualifies for rating 80 through 100 in the Storie Index Rating. The parcel contains 121 acres of vineyards and meets the income generation requirements for Prime contracts. Therefore, it meets the definition of Prime Agricultural land.

Be It Further Resolved that the Board of Supervisors finds the requested action categorically exempt from the California Environmental Quality Act pursuant to Section 15317 of the State CEQA Guidelines, which provides that establishment of Agricultural Preserves and the making of a new Land Conservation (Williamson) Act Contract is exempt from the California Environmental Quality Act.

Be It Further Resolved that the Board of Supervisors hereby grants the request by Steve Shaffer, Jack London Ranch, LLC, by approving a the expansion of Preserve 2-457 and the new Prime Land Conservation Act Contract and attached Land Conservation Plan, to restrict the 151.24 +/- acre parcel located at 2600 London Ranch Rd., Glen Ellen; APN 054-050-037.

Be It Further Resolved that the Clerk of the Board of Supervisors is hereby instructed to record within 20 days and no later than December 31, 2018 (1) this Resolution and (2) the associated Land Conservation Act Contract and attached Land Conservation Plan with the Office of the Sonoma County Recorder.

Be It Further Resolved that the Board of Supervisors designates the Clerk of the Board as the custodian of the documents and other material which constitute the record of proceedings upon which the decision herein is based. These documents may be found at the office of the Clerk of the Board, 575 Administration Drive, Room 100-A, Santa Rosa, California 95403.

Supervisors:

Gorin:

Rabbitt:

Zane:

Hopkins:

Gore:

Ayes:

Noes:

Absent:

Abstain:

So Ordered.

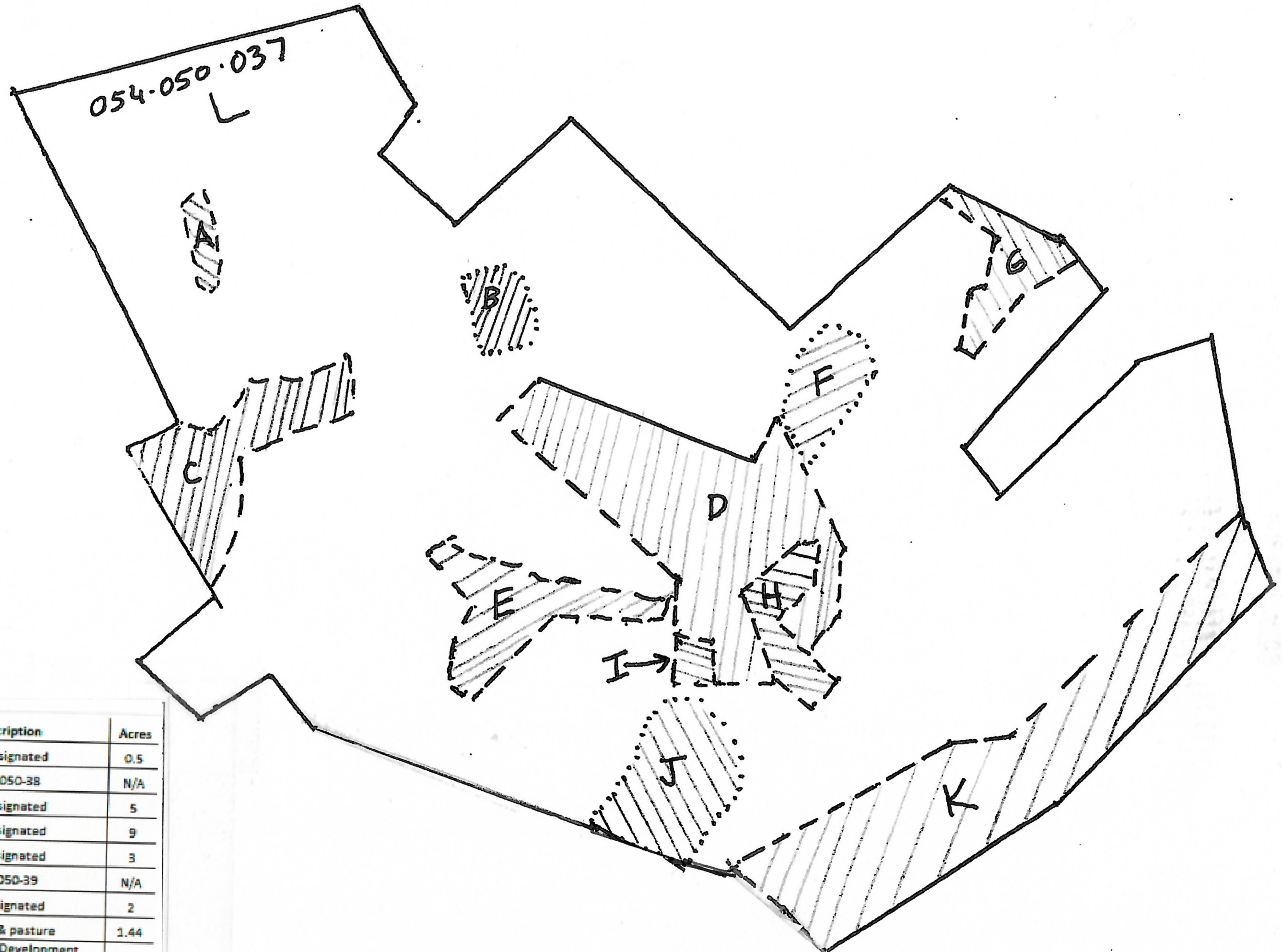

Area	Description	Acres
A	Undesignated	0.5
B	054-050-38	N/A
C	Undesignated	5
D	Undesignated	9
E	Undesignated	3
F	054-050-39	N/A
G	Undesignated	2
H	Ag Barn & pasture	1.44
I	Compatible Development (worker Housing) ~700 sq ft	0.3
J	054-050-16	N/A
K	Undesignated	9
L	Vineyard	121
Total Acreage		151.24

Attachment A Site Plan

AGP17-0011 NON-PARTICIPATING PARCELS

2600 London Ranch Road, Glen Ellen

APN 054-050-037



Project parcel in yellow

Vineyard: 121 acres

Agricultural improvements: 1.74 acres

Including 700 square foot agricultural worker housing unit, barn, corral, and pastureland

Undesignated oak woodland: 28.5 acres

Non-participating parcels in white

APNs 054-050-038, 054-050-039 & 054-050-040 were recorded under subdivision (MNS87-418).

The subject parcel was the designated remainder of that subdivision

Existing Agricultural Preserve Area

Proposed Agricultural Preserve Area

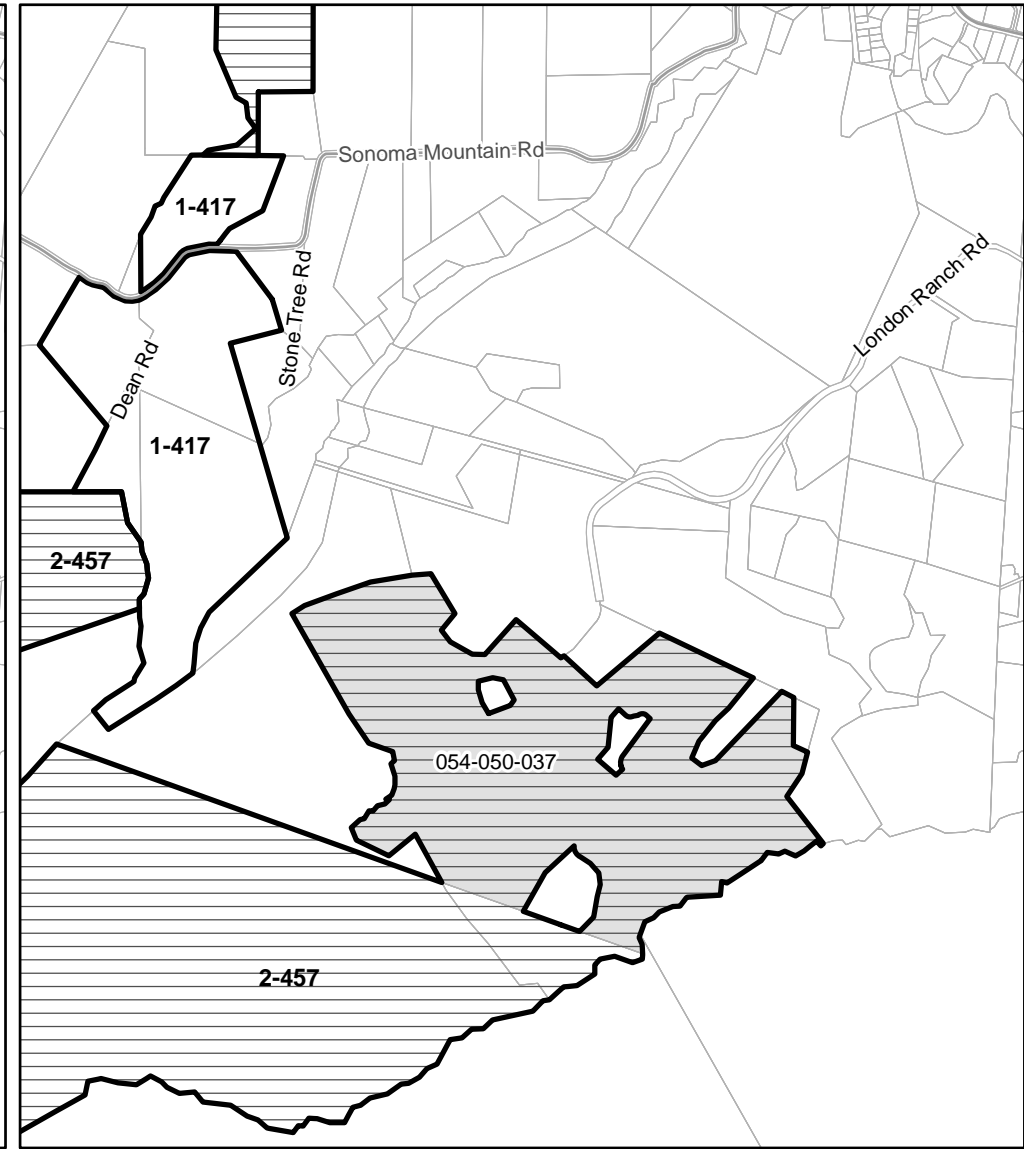
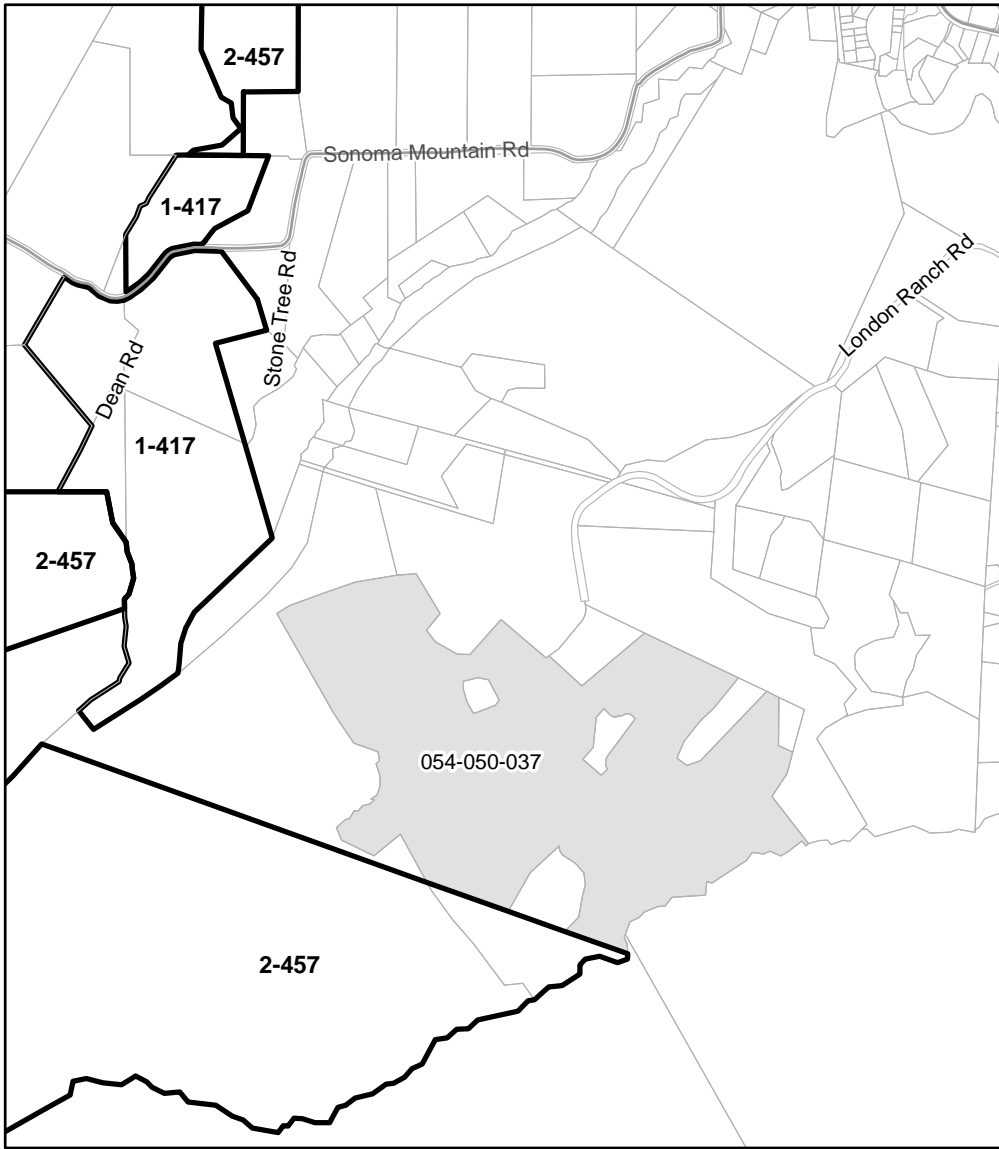

1 inch equals 1,500 feet

Agricultural Preserve Amendment Data

- Subject Area and/or Parcel
- Existing Agricultural Preserve Boundary
- Proposed Agricultural Preserve Boundary [Expand 2-457]

Basemap Data

- Parcels

File: AGP17-0011
 APN: 054-050-037
 Resolution No.: TBD
 Adopted Date: TBD

Agricultural Preserve Expansion

County of Sonoma
 Permit and Resource Management Department
 2550 Ventura Avenue, Santa Rosa, California 95403



County of Sonoma Agenda Item Summary Report

Clerk of the Board
575 Administration Drive
Santa Rosa, CA 95403

Agenda Item Number: 48
(This Section for use by Clerk of the Board Only.)

To: Sonoma County Board of Supervisors

Board Agenda Date: November 13, 2018

Vote Requirement: Majority

Department or Agency Name(s): Permit Sonoma

Staff Name and Phone Number:

Hannah Spencer x1928

Supervisorial District(s):

Fifth

Title: Technical Corrections to Zoning for Properties Located at 15600 Highway 1 and 14500 Meyers Grade Rd, Jenner; File ZCE18-0011

Recommended Actions:

Hold a public hearing and adopt three Resolutions and three Ordinances finding the project exempt from the California Environmental Quality Act (CEQA) and approving technical zoning corrections to the Official Zoning Database and Coastal Zoning Database for two legal parcels of record.

Executive Summary:

Permit Sonoma periodically identifies zoning and/or land use discrepancies to improve and maintain the accuracy of the Official Zoning Database (OZD) and Coastal Zoning Database. Any discrepancies and minor zoning amendments are then brought forward as technical corrections. Correcting zoning databases to accurately reflect applicable base zoning districts based on property boundaries eliminates split zoning and ensures the integrity and reliability of the information on which both the public and staff rely. The purpose of this request is to correct zoning errors that were made in the 1990's and to remove split zoning resulting from a subsequent lot line adjustment approval for 9.73 acres of land on two properties, located at 15600 Highway 1 and 14500 Meyers Grade Rd, Jenner. The request does not propose any changes to the General Plan or Local Coastal Plan Land-Use designations. On October 4, 2018, the Planning Commission reviewed the project and adopted resolutions recommending approval on a 5-0 vote.

Discussion:

Tom Berry, on behalf of the property owners Robert Mann, and Brian Wares and Rachel Curran, together with Permit Sonoma; are requesting amendments to the Official Zoning Database and Coastal Zoning Database for two legal parcels of record, located at 15600 Highway 1 and 14500 Meyers Grade Rd, Jenner. The properties are partially within the Coastal Zone, about 5 miles north of Jenner. Zoning for the properties is TP (Timberland Production), B6 160-acre density / TP (Timberland Production) CC

(Coastal Zone) B6 160/640-acre density/acres minimum, RC 50/50 (Riparian Corridor with 50-foot setbacks), RC 100/50 (Riparian Corridor with 100-foot and 50-foot setbacks), SR (Scenic Resources).

Background:

While processing the zone change request (ZCE18-0011), staff discovered zoning errors that resulted from transcribing zoning maps during the 1991 and 1993 zoning map updates. These zoning errors affect a total of 9.03 acres of land on the above listed properties. Without realizing the prior zoning errors, Permit Sonoma approved recordation of a lot line adjustment for the two properties (File No. LLA16-0023), which resulted in split zoning for both parcels and creation of additional Assessor Parcel Numbers. The purpose of this request is to correct the zoning errors made in the 1990's and as requested by the landowners, to complete minor zone changes to remove split zoning resulting from the lot line adjustment (LLA16-0023).

This application involves phasing a small portion of land out of TP (Timberland Production) zoning district and placing an equal amount of land into TP (Timberland Production) zoning district. Timberland Production zoning imposes additional land use restrictions for the purpose of conserving and protecting forestland and in exchange, the landowner receives the Timber Preserve Zone (TPZ) assessment-property tax benefit. Since 1982, the state has required all timberland zoned parcels to be within a TPZ, thus all timberland production-zoned land receives TPZ assessment. Similar to a Land Conservation contract, TPZs are in effect for 10 years and auto renew annually until the landowner files a zone change request to phase out of the TPZ assessment program. Details about each of the technical corrections and timberland zoning requirements are outlined in the attached Planning Commission Staff Report dated October 4, 2018.

General Plan, Local Coastal Plan, and Zoning Consistency:

Both parcels are designated "Resources and Rural Development Land Use" by the General Plan and "Timber Land Use" by the Local Coastal Plan. The project is consistent with the General Plan, Local Coastal Plan, and Zoning, as described in the attached Resolutions, in that the proposed changes do not result in changes to General Plan or Local Coastal Plan land use designations, nor in any changes to the assigned combining zone districts. Portions of both parcels lie within the Local Coastal Plan. Therefore, the parcels will remain with a split density of 160 acres per dwelling unit and 160/640 (acres per dwelling unit)/acres minimum with combining zones of CC (Coastal Zone), RC (Riparian Corridor) 50-foot and 100-foot setbacks, SR (Scenic Resources).

Environmental Review:

Adoption of the proposed ordinances is exempt from the California Environmental Quality Act (CEQA) pursuant to Section 15061(b)(3) (general rule/common sense) of the state CEQA Guidelines, as it can be seen with certainty that the project will have no significant effect on the environment since the project

consists of technical corrections that resolve inadvertent zoning errors and minor changes that remove split zoning resulting from a prior project approval.

To maintain a permanent record, staff prepared separate draft Ordinances for each zoning correction (Exhibits attached) as follows:

- Ordinance (Exhibit A) proposes to correct zoning errors made in 1991 and 1993 for land owned by Robert Mann, Brian Wares and Rachel Curran (affecting 9.03 acres total);
- Ordinance (Exhibit B) proposes to remove split zoning for land owned by Brian Wares and Rachel Curran (affecting 0.7 acres total); and,
- Ordinance (Exhibit C) proposes to remove split zoning for land owned by Robert Mann (affecting 0.7 acres total).

Prior Board Actions:

None.

Strategic Plan Alignment Goal 4: Civic Services and Engagement

Correcting zoning databases to accurately reflect applicable base zoning districts based on property boundaries eliminates split zoning and ensures the integrity and reliability of the information on which both the public and staff rely.

Fiscal Summary			
Expenditures	FY 18-19 Adopted	FY 19-20 Projected	FY 20-21 Projected
Budgeted Expenses			
Additional Appropriation Requested			
Total Expenditures			
Funding Sources			
General Fund/WA GF			
State/Federal			
Fees/Other			
Use of Fund Balance			
Contingencies			
Total Sources			
Narrative Explanation of Fiscal Impacts:			
N/A			
Staffing Impacts			
Position Title (Payroll Classification)	Monthly Salary Range (A – I Step)	Additions (Number)	Deletions (Number)
Narrative Explanation of Staffing Impacts (If Required):			
N/A			
Attachments:			
<ul style="list-style-type: none"> • Attachment A: Draft Resolution <ul style="list-style-type: none"> - Exhibit A: draft Ordinance with Exhibit to correct zoning errors made in 1991 and 1993 for land owned by Robert Mann, Brian Wares and Rachel Curran • Attachment B: Draft Resolution <ul style="list-style-type: none"> - Exhibit B: draft Ordinance with Exhibit to remove split zoning for land owned by Brian Wares and Rachel Curran • Attachment C: Draft Resolution <ul style="list-style-type: none"> - Exhibit C: draft Ordinance with Exhibit to remove split zoning for land owned by Robert Mann 			

- Attachment D: Planning Commission staff report and Resolutions
- Attachment E: Draft Planning Commission October 4, 2018 Meeting Minutes

Related Items “On File” with the Clerk of the Board:

None.



County of Sonoma

State of California

Date: November 13, 2018

Item Number: _____

Resolution Number: _____

ZCE18-0011 Hannah Spencer



4/5 Vote Required

Resolution of the Board of Supervisors of the County of Sonoma, State of California, finding the project exempt from the California Environmental Quality Act (CEQA), approving amendments to the Official Zoning Database and Coastal Zoning Database, and directing the submission of the amendments to the California Coastal Commission for approval, for property located at 15600 Highway 1 and 14500 Meyers Grade Road, Jenner; APN 109-170-032, -033, and -034; Supervisorial District No. 5.

Whereas, the applicant, Tom Berry, filed an application with the Sonoma County Permit and Resource Management Department to rezone 9.03 acres of land from the TP (Timberland Production), B6 160-acre density / TP (Timberland Production) CC (Coastal Zone) B6 160/640-acre density/acres minimum, RC 50/50 (Riparian Corridor with 50-foot setbacks), RC 100/50 (Riparian Corridor with 100-foot and 50-foot setbacks), SR (Scenic Resources) to the RRD (Resources and Rural Development) B6 160-acre density / RRD (Resources and Rural Development) CC (Coastal Zone) B6 160/640-acre density/acres minimum, RC 50/50 (Riparian Corridor 50-foot setbacks), RC 100/50 (Riparian Corridor with 100-foot and 50-foot setbacks), SR (Scenic Resources) district, or other appropriate district on property located at 15600 Highway 1 and 14500 Meyers Grade Road, Jenner; APN 109-170-032, -033, and -034; Supervisorial District No. 5; and,

Whereas, this project has been found to be categorically exempt from CEQA pursuant to CEQA Guidelines, Section 15061(b)(3) as it can be seen with certainty that the project will have no significant effect on the environment since the project consists of technical corrections and minor changes that resolve zoning errors; and,

Whereas, Permit Sonoma periodically identifies zoning and/or land use discrepancies to improve and maintain the accuracy of the Official Zoning Database and Coastal Zoning Database. Any discrepancies and minor zoning amendments are then brought forward as technical corrections to improve the zoning databases; and,

Whereas, while processing PRMD File No. ZCE18-0011, Permit Sonoma staff discovered zoning discrepancies that affect Robert Mann's parcel located at 15600 Highway 1 (APN 109-170-032, -033) and Rachel Curran's and Brian Wares' ("the Currans") parcel located at 14500 Meyers Grade Rd (APN 109-170-034); and,

Whereas, historic zoning maps and PRMD records show the County inadvertently rezoned the Currans' land in 1991, from the A1 (Primary Agriculture) / AP (Primary Agriculture) base zoning district to the A1 (Primary Agriculture) / TP (Timberland Production) base zoning district; and again in 1993, by rezoning the Currans' land from the A1 (Primary Agriculture) / TP (Timberland Production) base zoning district to the TP (Timberland Production) base zoning district; and

Whereas, the Board of Supervisors adopted Ordinance No. 4643 rezoning agricultural and resource lands to match the new General Plan designations and lands in the remote coastal mountain ranges that were previously designated as A1 (Primary Agriculture) and AP (Primary Agriculture) and had no agriculture and/or were not capable of supporting an economically viable agricultural enterprise (due to constraints such as parcel size, soils, and water availability), were rezoned to the RRD (Resources and Rural Development) base zoning district; and,

Whereas, consistent with Ordinance No. 4643, the Currans' land located at 14500 Meyers Grade Rd (formerly identified as APN 109-170-010) should have been rezoned from the A1 (Primary Agriculture) / AP (Primary Agriculture) base zoning districts to the RRD (Resources and Rural Development) base zoning district during the 1993 zoning map update; and,

Whereas, in 2016, 0.7 acres of land was exchanged between the Currans' and Robert Mann in Lot Line Adjustment File No. LLA16-0023 and as a result, 0.7 acres of inaccurately zoned land (currently identified as APN 109-170-032 and -033) was transferred to Robert Mann; and

Whereas, the proposed zone change will correct technical zoning errors that resulted from the inadvertent rezoning that occurred in 1991 and 1993, affecting land identified as APN 109-170-032, -033, and -034; and

Whereas, the California Coastal Act requires a resolution adopted by the legislative body formally submitting an ordinance for certification by the Coastal Commission; and

Whereas, in accordance with the provisions of law, the Planning Commission held a public hearing on October 4, 2018, at which time all interested persons were given an opportunity to be heard; and

Whereas, by a 5-0 vote, the Planning Commission adopted Resolution number 18-018 recommending that the Board of Supervisors find the project to be exempt from CEQA and approve the requested amendments to the Official Zoning Database and Coastal

Resolution #

Date: November 13, 2018

Page 3

Zoning Database.

Now, Therefore, be it Resolved, that the Board of Supervisors, having considered the file information, report from staff, and all public comments, and the proposed Ordinance does make the following findings:

1. The proposed zone changes are necessary to correct errors in the Official Zoning Database and Coastal Zoning Database that resulted from inadvertent rezoning in 1991 and 1993 and to ensure the accuracy and reliability of the planning information on which the public relies.
2. The proposed zone changes are consistent and compatible with the Sonoma County General Plan and Local Coastal Plan in that the changes include technical corrections to zoning that will not result in changes to the Resources and Rural Development Land Use Designation of the General Plan nor to the Timber Land Use Designation of the Local Coastal Plan. The "General Plan/Coastal Plan/Zoning Consistency" table in Appendix E of the adopted Local Coastal Plan provides that the Timberland Production and Resources and Rural Development zoning districts are consistent with both and the Resources and Rural Development Land Use Designation of the General Plan and the Timber Land Use Designation of the Local Coastal Plan. The proposed changes are being undertaken to ensure consistency with the Local Coastal Plan and land use maps are consistent with the purpose and intent of the Coastal Act.
3. The proposed zone changes are non-substantive in nature and will not change the development potential that would otherwise be allowed by the Local Coastal Plan.
4. The project is exempt from the California Environmental Quality Act under the General Rule, Section 15061(b)(3), as it can be seen with certainty that the project will not have a significant effect on the environment because the proposed changes to the Official Zoning Database and Coastal Zoning Database consist of technical corrections and minor changes that resolve inadvertent zoning errors to ensure the accuracy and reliability of the County's zoning information and further, that the proposed changes will not result in any physical change to land or increase development potential; and

Be It Further Resolved that the Board authorizes staff to submit the zone changes to the Coastal Zoning Database to the California Coastal Commission for certification.

Resolution #

Date: November 13, 2018

Page 4

Be It Further Resolved that the County of Sonoma will carry out the above Sonoma County Local Coastal Program Amendment in a manner fully consistent with the California Coastal Act (Coastal Act Section 30510) and that these amendments will take place automatically upon Coastal Commission certification.

Be It Further Resolved, that the Board of Supervisors designates the Clerk of the Board as the custodian of the documents and other material which constitute the record of proceedings upon which the decision herein is based, including the original executed Contract and Land Conservation Plan. These documents may be found at the office of the Clerk of the Board, 575 Administration Drive, Room 100-A, Santa Rosa, California 95403.

Supervisors:

Gorin:

Rabbitt:

Zane:

Hopkins:

Gore:

Ayes:

Noes:

Absent:

Abstain:

So Ordered.

ORDINANCE NO. ()

AN ORDINANCE OF THE BOARD OF SUPERVISORS OF THE COUNTY OF SONOMA, STATE OF CALIFORNIA, AMENDING THE OFFICIAL ZONING DATABASE AND COASTAL ZONING DATABASE OF THE COUNTY OF SONOMA, ADOPTED BY REFERENCE BY SECTION 26-02-110 OF THE SONOMA COUNTY CODE, BY RECLASSIFYING CERTAIN REAL PROPERTY FROM THE TP (TIMBERLAND PRODUCTION), B6 160-ACRE DENSITY / TP (TIMBERLAND PRODUCTION) CC (COASTAL ZONE) B6 160/640-ACRE DENSITY/ACRES MINIMUM, RC 50/50 (RIPARIAN CORRIDOR WITH 50-FOOT SETBACKS), RC 100/50 (RIPARIAN CORRIDOR WITH 100-FOOT AND 50-FOOT SETBACKS), SR (SCENIC RESOURCES) TO THE RRD (RESOURCES AND RURAL DEVELOPMENT), B6 160-ACRE DENSITY / RRD (RESOURCES AND RURAL DEVELOPMENT) CC (COASTAL ZONE) B6 160/640-ACRE DENSITY/ACRES MINIMUM, RC 50/50 (RIPARIAN CORRIDOR WITH 50-FOOT SETBACKS), RC 100/50 (RIPARIAN CORRIDOR WITH 100-FOOT AND 50-FOOT SETBACKS), SR (SCENIC RESOURCES) ZONING DISTRICT FOR 9.03 ACRES OF LAND LOCATED AT 15600 HIGHWAY 1 AND 14500 MEYERS GRADE ROAD, JENNER; APN 109-170-032, -033, AND -034.

The Board of Supervisors of the County of Sonoma, State of California, ordains as follows:

Section I. The Official Zoning Database (OZD) and Coastal Zoning Database (CZD) of the County, adopted by reference by Section 26-02-110 of the Sonoma County Code, are amended by reclassifying the following real property from the TP (Timberland Production), B6 160-acre density / TP (Timberland Production) CC (Coastal Zone) B6 160/640-acre density/acres minimum, RC 50/50 (Riparian Corridor with 50-foot setbacks), RC 100/50 (Riparian Corridor with 100-foot and 50-foot setbacks), SR (Scenic Resources) to the RRD (Resources and Rural Development) B6 160-acre density / RRD (Resources and Rural Development) CC (Coastal Zone) B6 160/640-acre density/acres minimum, RC 50/50 (Riparian Corridor 50-foot setbacks), RC 100/50 (Riparian Corridor with 100-foot and 50-foot setbacks), SR (Scenic Resources) district, for 9.03 acres of land located at located at 15600 Highway 1 and 14500 Meyers Grade Road, Jenner; APN 109-170-032, -033, and -034. File No. ZCE18-0011. The Director of the Permit and Resource Management Department is directed to reflect this amendment in the OZD and the CZD of the County as shown on the attached Exhibit A.

Section II. The Proposed Project is exempt from the California Environmental Quality Act (CEQA) pursuant to Section 15061(b)(3) of the State CEQA guidelines as it can be seen with certainty that the project will have no significant effect on the environment since the project consists of a technical corrections and minor changes that resolve inadvertent zoning errors.

Section III. If any section, subsection, sentence, clause, or phrase of this Ordinance is for any reason held to be unconstitutional or invalid, such decision shall not affect the

validity of the remaining portion of this Ordinance. The Board of Supervisors hereby declares that it would have passed this Ordinance and every section, subsection, sentence, clause or phrase thereof irrespective of the fact that any one or more sections, subsections, sentences, clauses or phrases be declared unconstitutional or invalid.

SECTION IV: This Ordinance shall be and the same is hereby declared to be in full force and effect automatically from and after thirty (30) days following California Coastal Commission certification, and shall be carried out in a manner fully consistent with the California Coastal Act. This item involves an amendment to the Local Coastal Program and is not effective until and unless approved by the California Coastal Commission.

SECTION V: This Ordinance shall be published once before the expiration of fifteen (15) days after said passage, with the names of the Supervisors voting for or against the same, in a newspaper of general circulation, published in the County of Sonoma, State of California.

In regular session of the Board of Supervisors of the County of Sonoma, introduced on the ___ day of ___, 2018, and finally passed and adopted this ___ day of ___, 2018, on regular roll call of the members of said Board by the following vote:

SUPERVISORS:

Gorin: ___ Rabbitt: ___ Zane: ___ Hopkins: ___ Gore: ___

Ayes: ___ Noes: ___ Absent: ___ Abstain: ___

WHEREUPON, the Chair declared the above and foregoing Ordinance duly adopted and

SO ORDERED.

James Gore
Chair, Board of Supervisors
County of Sonoma

ATTEST:

Sheryl Bratton,
Clerk of the Board of Supervisors

Existing Zoning

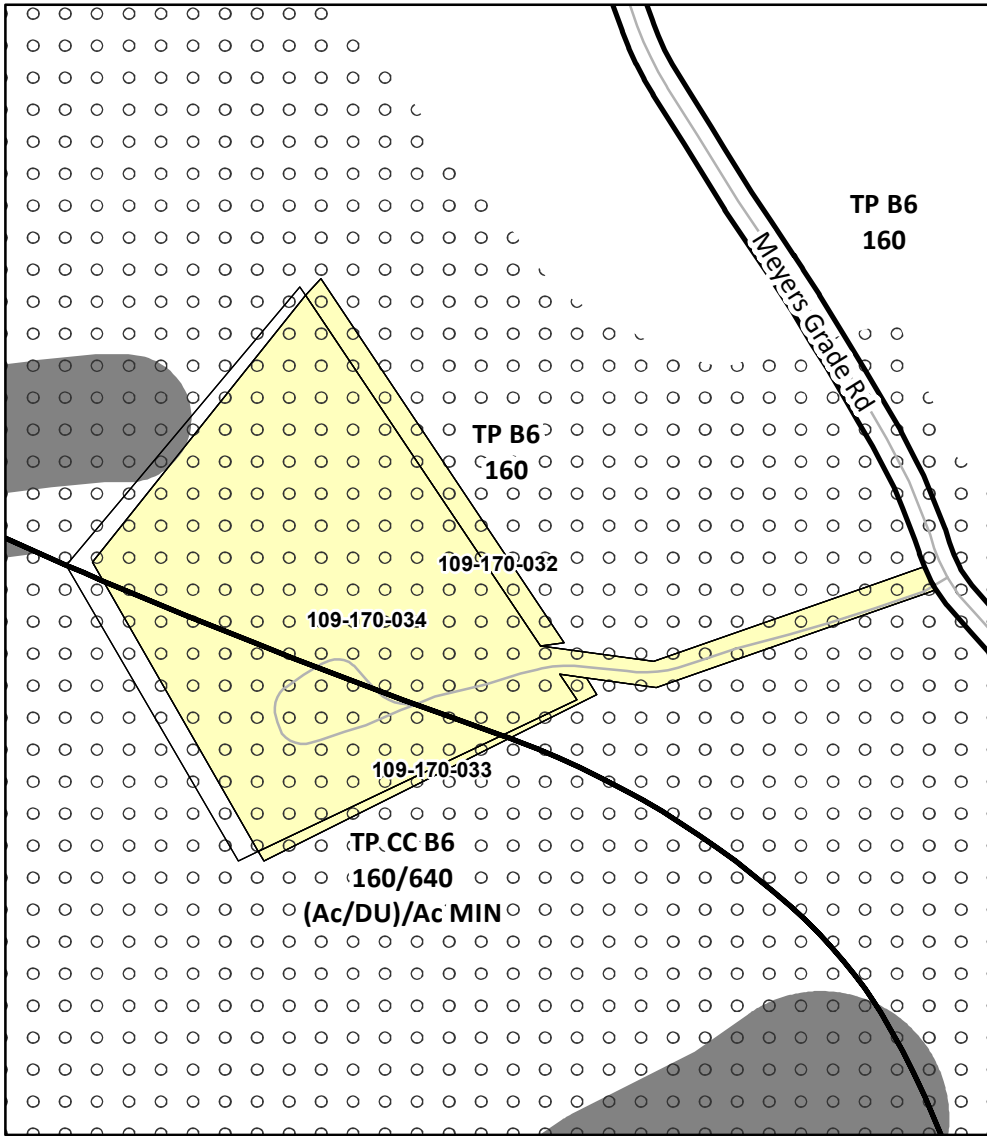

Proposed Zoning

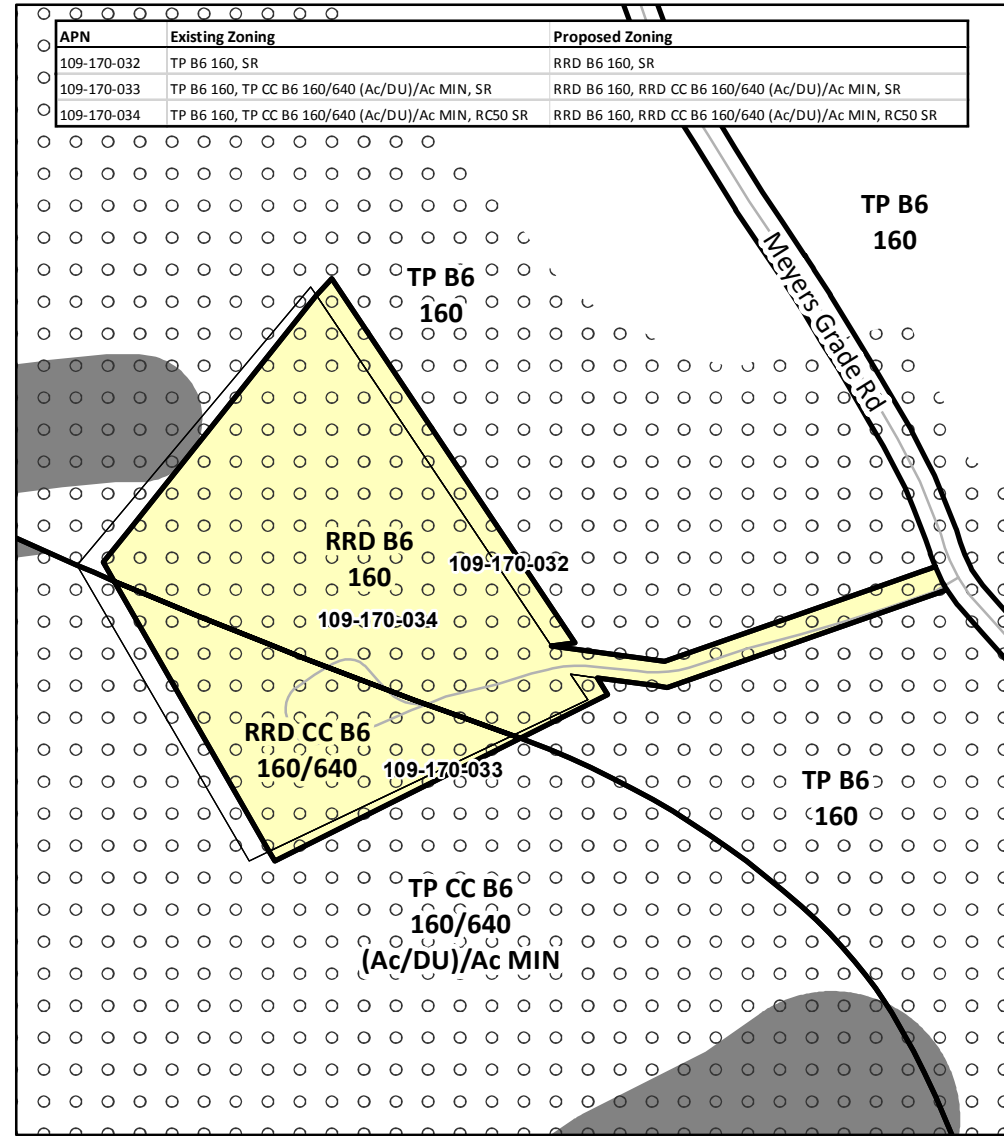

APN	Existing Zoning	Proposed Zoning
109-170-032	TP B6 160, SR	RRD B6 160, SR
109-170-033	TP B6 160, TP CC B6 160/640 (Ac/DU)/Ac MIN, SR	RRD B6 160, RRD CC B6 160/640 (Ac/DU)/Ac MIN, SR
109-170-034	TP B6 160, TP CC B6 160/640 (Ac/DU)/Ac MIN, RC50 SR	RRD B6 160, RRD CC B6 160/640 (Ac/DU)/Ac MIN, RC50 SR

Base Map Data

- Subject Parcel
- Parcel
- Basezoning by Area
- Street

Zoning Combining Districts

- RC Riparian Corridor
- SR Scenic Resource

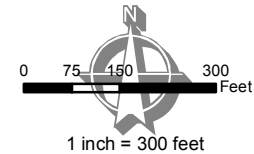

FILE: ZCE18-0011-A
 APNs: 109-170-032, -033, & -034
 Ordinance No. TBD
 Sectional District Map No. TBD

Permit and Resource Management Department
 Project Review Section
 2550 Ventura Avenue, Santa Rosa, CA 95403
 (707) 565-1965 Fax (707) 565-1103



County of Sonoma

State of California

Date: November 13, 2018

Item Number: _____
Resolution Number: _____

ZCE18-0011 Hannah Spencer

4/5 Vote Required

Resolution of the Board of Supervisors of the County of Sonoma, State of California, finding the project exempt from the California Environmental Quality Act (CEQA), approving an amendment to the Official Zoning Database and Coastal Zoning Database, and directing the submission of the amendment to the California Coastal Commission for approval, for property located at 14500 Meyers Grade Road, Jenner; APN 109-170-035; Supervisorial District No. 5.

Whereas, the applicant, Tom Berry, filed an application with the Sonoma County Permit and Resource Management Department to rezone 0.7 acres of land from the TP (Timberland Production), B6 160-acre density / TP (Timberland Production) CC (Coastal Zone) B6 160/640-acre density/acres minimum, RC 50/50 (Riparian Corridor with 50-foot setbacks), RC 100/50 (Riparian Corridor with 100-foot and 50-foot setbacks), SR (Scenic Resources) to the RRD (Resources and Rural Development) B6 160-acre density / RRD (Resources and Rural Development) CC (Coastal Zone) B6 160/640-acre density/acres minimum, RC 50/50 (Riparian Corridor 50-foot setbacks), RC 100/50 (Riparian Corridor with 100-foot and 50-foot setbacks), SR (Scenic Resources) district, or other appropriate district on property located at 14500 Meyers Grade Road, Jenner; APN 109-170-035; Supervisorial District No. 5; and,

Whereas, this project has been found to be categorically exempt from CEQA pursuant to CEQA Guidelines, Section 15061(b)(3) as it can be seen with certainty that the project will have no significant effect on the environment since the project consists of a minor change that removes split zoning resulting from a prior project approval; and,

Whereas, Permit Sonoma periodically identifies zoning and/or land use discrepancies to improve and maintain the accuracy of the Official Zoning Database and Coastal Zoning Database. Any discrepancies and minor zoning amendments are then brought forward as technical corrections to improve the zoning databases; and,

Resolution #

Date: November 13, 2018

Page 2

Whereas, while processing PRMD File No. ZCE18-0011, Permit Sonoma staff discovered the approval and recordation of Lot Line Adjustment File No. LL16-0023 between Brian Wares' and Rachel Curran's ("the Currans) land located at 14500 Meyers Grade Rd (formerly APN 109-170-010; currently APN 109-170-034, -035) and Robert Mann's land located at 15600 Highway 1 (formerly APN 109-170-023; currently APN 109-170-032, -033, -036) resulted in split zoning in which the Currans received 0.7 acres of land that is zoned TP (Timberland Production) with Timber Preserve Zone (TPZ) Assessment; and

Whereas, the majority of the Currans' land (APN 109-170-034) is zoned RRD (Resources and Rural Development); and,

Whereas, to remove the split zoning that resulted from LLA16-0023 on the Currans' land consistent with Government Code Section 51120, the Board of Supervisors must authorize the County Assessor to phase the Currans' 0.7 acres of land located at 14500 Meyers Grade Road, Jenner (APN 109-170-035), out of TPZ Assessment; and,

Whereas, effective 10 years from the date of approval, the Official Zoning Database and Coastal Zoning Database will identify 0.7 acres of land located at 14500 Meyers Grade Road, Jenner (APN 109-170-035) with a RRD (Resources and Rural Development) base zoning district; and,

Whereas, property taxes for land located at 14500 Meyers Grade Road, Jenner (APN 109-170-035), will increase immediately upon approval of the rezoning, and continue to increase annually and incrementally over the ensuing 10 years that the TPZ Assessment restrictions remain in place; and,

Whereas, the California Coastal Act requires a resolution adopted by the legislative body formally submitting an ordinance for certification by the Coastal Commission; and

Whereas, in accordance with the provisions of law, the Planning Commission held a public hearing on October 4, 2018, at which time all interested persons were given an opportunity to be heard; and

Whereas, by a 5-0 vote, the Planning Commission adopted Resolution number 18-020 recommending that the Board of Supervisors find the project to be exempt from CEQA and approve the requested amendment to the Official Zoning Database and Coastal Zoning Database.

Now, Therefore, be it Resolved, that the Board of Supervisors, having considered the file information, report from staff, and all public comments, and the proposed Ordinance does make the following findings:

1. The proposed zone change is necessary to remove split zoning in the Official Zoning Database and Coastal Zoning Database that resulted from prior

approval of File No. LLA16-0023 to ensure the accuracy and reliability of the planning information on which the public relies.

2. The proposed zone change is consistent and compatible with the Sonoma County General Plan and Local Coastal Plan in that the proposed change includes a technical correction to zoning that will not result in changes to the Resources and Rural Development Land Use Designation of the General Plan nor to the Timber Land Use Designation of the Local Coastal Plan. The “General Plan/Coastal Plan/Zoning Consistency” table in Appendix E of the adopted Local Coastal Plan provides that the Timberland Production and Resources and Rural Development zoning districts are consistent with both and the Resources and Rural Development Land Use Designation of the General Plan and the Timber Land Use Designation of the Local Coastal Plan. The proposed change is being undertaken to ensure consistency with the Local Coastal Plan and land use maps is consistent with the purpose and intent of the Coastal Act.
3. Authorizing 0.7 acres of the Currans’ land located at 14500 Meyers Grade Road, Jenner (APN 109-170-035) to phase out of TPZ Assessment, is consistent with Government Code Sections 51120 and 51140.
4. The proposed zone change is non-substantive in nature and will not change the development potential that would otherwise be allowed by the Local Coastal Plan.
5. The project is exempt from the California Environmental Quality Act under the General Rule, Section 15061(b)(3), as it can be seen with certainty that the project will not have a significant effect on the environment because the proposed change to the Official Zoning Database and Coastal Zoning Database consists of a technical correction that removes split zoning resulting from a prior project approval and further, that the proposed change will not result in any physical change to land or increase development potential; and

Be It Further Resolved, that the Board authorizes the County Assessor to phase the Currans’ 0.7 acres of land located at 14500 Meyers Grade Road, Jenner (APN 109-170-035), out of TPZ Assessment; and,

Be It Further Resolved, that the Board authorizes staff to submit the zone change to the Coastal Zoning Database to the California Coastal Commission for certification.

Resolution #

Date: November 13, 2018

Page 4

Be It Further Resolved that the County of Sonoma will carry out the above Sonoma County Local Coastal Program Amendment in a manner fully consistent with the California Coastal Act (Coastal Act Section 30510) and that the amendment will take place automatically upon Coastal Commission certification.

Be It Further Resolved, that the Board of Supervisors designates the Clerk of the Board as the custodian of the documents and other material which constitute the record of proceedings upon which the decision herein is based, including the original executed Contract and Land Conservation Plan. These documents may be found at the office of the Clerk of the Board, 575 Administration Drive, Room 100-A, Santa Rosa, California 95403.

Supervisors:

Gorin:

Rabbitt:

Zane:

Hopkins:

Gore:

Ayes:

Noes:

Absent:

Abstain:

So Ordered.

ORDINANCE NO. ()

AN ORDINANCE OF THE BOARD OF SUPERVISORS OF THE COUNTY OF SONOMA, STATE OF CALIFORNIA, AMENDING THE OFFICIAL ZONING DATABASE AND COASTAL ZONING DATABASE OF THE COUNTY OF SONOMA, ADOPTED BY REFERENCE BY SECTION 26-02-110 OF THE SONOMA COUNTY CODE, BY RECLASSIFYING CERTAIN REAL PROPERTY FROM THE TP (TIMBERLAND PRODUCTION), B6 160-ACRE DENSITY / TP (TIMBERLAND PRODUCTION) CC (COASTAL ZONE) B6 160/640-ACRE DENSITY/ACRES MINIMUM, RC 50/50 (RIPARIAN CORRIDOR WITH 50-FOOT SETBACKS), RC 100/50 (RIPARIAN CORRIDOR WITH 100-FOOT AND 50-FOOT SETBACKS), SR (SCENIC RESOURCES) TO THE RRD (RESOURCES AND RURAL DEVELOPMENT), B6 160-ACRE DENSITY / RRD (RESOURCES AND RURAL DEVELOPMENT) CC (COASTAL ZONE) B6 160/640-ACRE DENSITY/ACRES MINIMUM, RC 50/50 (RIPARIAN CORRIDOR WITH 50-FOOT SETBACKS), RC 100/50 (RIPARIAN CORRIDOR WITH 100-FOOT AND 50-FOOT SETBACKS), SR (SCENIC RESOURCES) ZONING DISTRICT FOR 0.7 ACRES LOCATED AT 14500 MEYERS GRADE ROAD, JENNER; APN 109-170-035.

The Board of Supervisors of the County of Sonoma, State of California, ordains as follows:

Section I. The Official Zoning Database (OZD) and Coastal Zoning Database (CZD) of the County, adopted by reference by Section 26-02-110 of the Sonoma County Code, are amended by reclassifying the following real property from the TP (Timberland Production), B6 160-acre density / TP (Timberland Production) CC (Coastal Zone) B6 160/640-acre density/acres minimum, RC 50/50 (Riparian Corridor with 50-foot setbacks), RC 100/50 (Riparian Corridor with 100-foot and 50-foot setbacks), SR (Scenic Resources) to the RRD (Resources and Rural Development) B6 160-acre density / RRD (Resources and Rural Development) CC (Coastal Zone) B6 160/640-acre density/acres minimum, RC 50/50 (Riparian Corridor 50-foot setbacks), RC 100/50 (Riparian Corridor with 100-foot and 50-foot setbacks), SR (Scenic Resources) district, for 0.7 acres of land located at located at 14500 Meyers Grade Road, Jenner; APN 109-170-035. File No. ZCE18-0011. The Director of the Permit and Resource Management Department is directed to reflect this amendment in the OZD and the CZD of the County as shown on the attached Exhibit A.

Section II. The Proposed Project is exempt from the California Environmental Quality Act (CEQA) pursuant to Section 15061(b)(3) of the State CEQA guidelines as it can be seen with certainty that the project will have no significant effect on the environment since the project consists of a technical correction and minor change that removes split zoning resulting from a prior project approval.

Section III. On the date 10 years from the effective date of the ordinance, the Official Zoning Database and Coastal Zoning Database will identify 0.7 acres of land located at 14500 Meyers Grade Road, Jenner (APN 109-170-035), with a RRD (Resources and

Rural Development) base zoning district. As part of the rezone, the Board of Supervisors approve the County Assessor to phase APN 109-170-035 out of Timber Production Zone (TPZ) Assessment. Property taxes for APN 109-170-035 will increase immediately upon approval of the rezoning, and continue to increase annually and incrementally over the ensuing 10 years that the TPZ Assessment restrictions remain in place.

Section IV. If any section, subsection, sentence, clause, or phrase of this Ordinance is for any reason held to be unconstitutional or invalid, such decision shall not affect the validity of the remaining portion of this Ordinance. The Board of Supervisors hereby declares that it would have passed this Ordinance and every section, subsection, sentence, clause or phrase thereof irrespective of the fact that any one or more sections, subsections, sentences, clauses or phrases be declared unconstitutional or invalid.

SECTION V: This Ordinance shall be and the same is hereby declared to be in full force and effect automatically from and after thirty (30) days following California Coastal Commission certification, and shall be carried out in a manner fully consistent with the California Coastal Act. This item involves an amendment to the Local Coastal Program and is not effective until and unless approved by the California Coastal Commission.

SECTION VI: This Ordinance shall be published once before the expiration of fifteen (15) days after said passage, with the names of the Supervisors voting for or against the same, in a newspaper of general circulation, published in the County of Sonoma, State of California.

In regular session of the Board of Supervisors of the County of Sonoma, introduced on the ___ day of ___, 2018, and finally passed and adopted this ___ day of ___, 2018, on regular roll call of the members of said Board by the following vote:

SUPERVISORS:

Gorin: ___ Rabbitt: ___ Zane: ___ Hopkins: ___ Gore: ___

Ayes: _____ Noes: _____ Absent: _____ Abstain: _____

WHEREUPON, the Chair declared the above and foregoing Ordinance duly adopted and

SO ORDERED.

James Gore
Chair, Board of Supervisors
County of Sonoma

ATTEST:

Sheryl Bratton,
Clerk of the Board of Supervisors

Existing Zoning

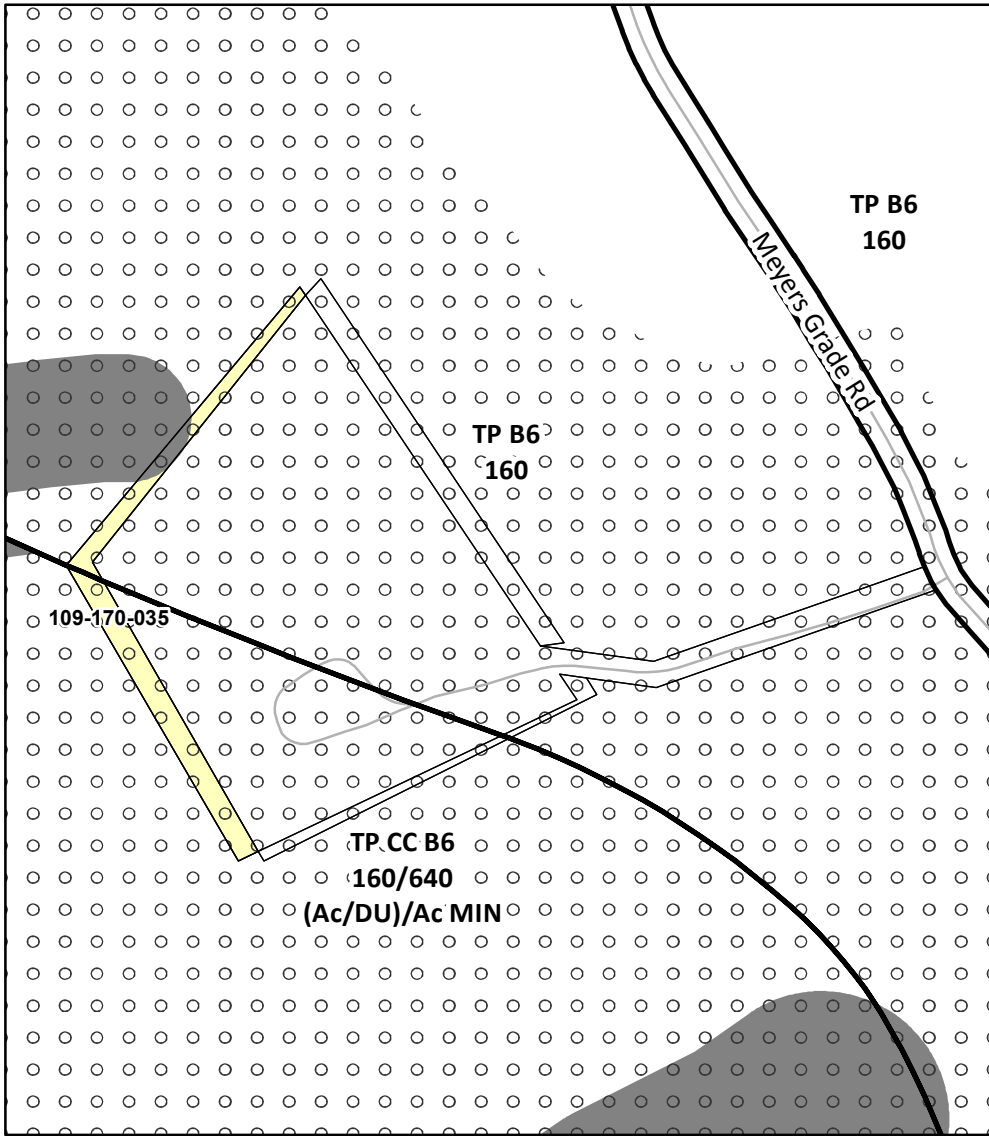



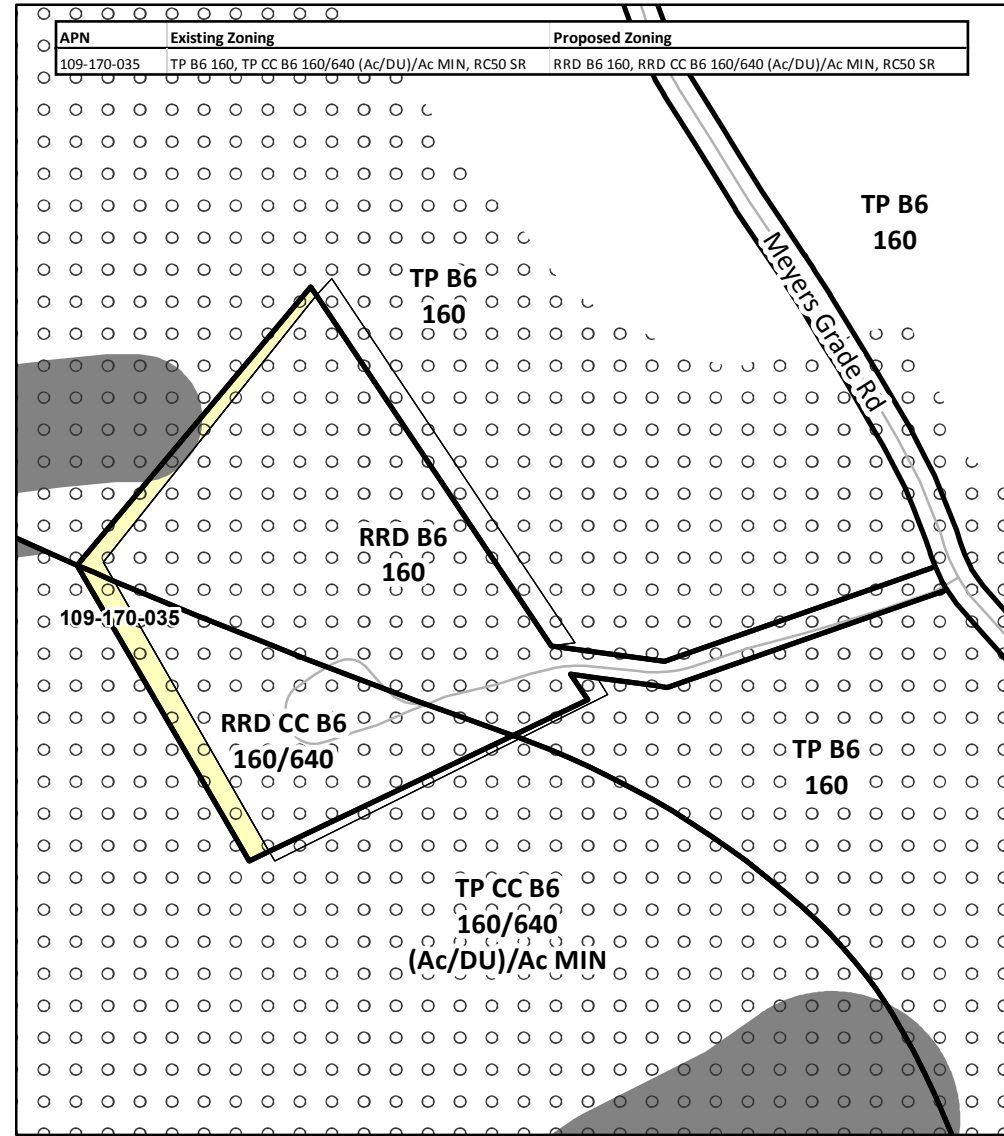

Proposed Zoning





APN	Existing Zoning	Proposed Zoning
109-170-035	TP B6 160, TP CC B6 160/640 (Ac/DU)/Ac MIN, RC50 SR	RRD B6 160, RRD CC B6 160/640 (Ac/DU)/Ac MIN, RC50 SR

Base Map Data

-  Subject Parcel
-  Parcel
-  Basezoning by Area
-  Street

Zoning Combining Districts

-  RC Riparian Corridor
-  SR Scenic Resource

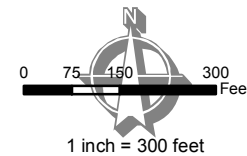

FILE: ZCE18-0011-C
 APN: 109-170-035
 Ordinance No. TBD
 Sectional District Map No. TBD

Permit and Resource Management Department
 Project Review Section
 2550 Ventura Avenue, Santa Rosa, CA 95403
 (707) 565-1965 Fax (707) 565-1103



County of Sonoma

State of California

Date: November 13, 2018

Item Number: _____

Resolution Number: _____

ZCE18-0011 Hannah Spencer



4/5 Vote Required

Resolution of the Board of Supervisors of the County of Sonoma, State of California, finding the project exempt from the California Environmental Quality Act (CEQA), approving an amendment to the Official Zoning Database and Coastal Zoning Database, and directing the submission of the amendment to the California Coastal Commission for approval, for property located at 15600 Highway 1, Jenner; APN 109-170-032, and -033; Supervisorial District No. 5.

Whereas, the applicant, Tom Berry, filed an application with the Sonoma County Permit and Resource Management Department to rezone 0.7 acres of land from the RRD (Resources and Rural Development) B6 160-acre density / RRD (Resources and Rural Development) CC (Coastal Zone) B6 160/640-acre density/acres minimum, RC 50/50 (Riparian Corridor 50-foot setbacks), RC 100/50 (Riparian Corridor with 100-foot and 50-foot setbacks), SR (Scenic Resources) district to the TP (Timberland Production), B6 160-acre density / TP (Timberland Production) CC (Coastal Zone) B6 160/640-acre density/acres minimum, RC 50/50 (Riparian Corridor with 50-foot setbacks), RC 100/50 (Riparian Corridor with 100-foot and 50-foot setbacks), SR (Scenic Resources) district on property located at 15600 Highway 1, Jenner; APN 109-170-032 and -033; Supervisorial District No. 5,

Whereas, this project has been found to be categorically exempt from CEQA pursuant to CEQA Guidelines, Section 15061(b)(3) as it can be seen with certainty that the project will have no significant effect on the environment since the project consists of a minor change that removes split zoning resulting from a prior project approval; and,

Whereas, Permit Sonoma periodically identifies zoning and/or land use discrepancies to improve and maintain the accuracy of the Official Zoning Database and Coastal Zoning Database. Any discrepancies and minor zoning amendments are then brought forward as technical corrections to improve the zoning databases; and,

Resolution #

Date: November 16, 2018

Page 2

Whereas, while processing PRMD File No. ZCE18-0011, Permit Sonoma staff discovered inadvertent split zoning that resulted from approval of LLA16-0023, affecting Robert Mann's parcel located at 15600 Highway 1 (APN 109-170-032, -033); and

Whereas, the 0.7 acres of land located at 15600 Highway 1, Jenner (APN 109-170-032, -033) contains the soils and climate capable of producing timber and is contiguous to timberland already zoned as timberland production; and,

Whereas, the proposed zone change will remove the split zoning resulting from approval and recordation of LLA16-0023; and,

Whereas, consistent with Government Code Section 51113.5, the Board of Supervisors must authorize the County Assessor to assign Timber Preserve Zone (TPZ) Assessment to Robert Mann's land located at 15600 Highway 1, Jenner (APN 109-170-032, -033); and,

Whereas, the California Coastal Act requires a resolution adopted by the legislative body formally submitting an ordinance for certification by the Coastal Commission; and

Whereas, in accordance with the provisions of law, the Planning Commission held a public hearing on October 4, 2018, at which time all interested persons were given an opportunity to be heard; and

Whereas, by a 5-0 vote, the Planning Commission adopted Resolution number 18-019 recommending that the Board of Supervisors find the project to be exempt from CEQA and approve the requested amendment to the Official Zoning Database and Coastal Zoning Database.

Now, Therefore, be it Resolved, that the Board of Supervisors, having considered the file information, report from staff, and all public comments, and the proposed Ordinance does make the following findings:

1. The proposed zone change is necessary to remove split zoning in the Official Zoning Database and Coastal Zoning Database that resulted from prior approval of File No. LLA16-0023 to ensure the accuracy and reliability of the planning information on which the public relies.
2. The proposed zone change is consistent and compatible with the Sonoma County General Plan and Local Coastal Plan in that the proposed change includes a technical correction to zoning that will not result in changes to the Resources and Rural Development Land Use Designation of the General Plan nor to the Timber Land Use Designation of the Local Coastal Plan. The "General Plan/Coastal Plan/Zoning Consistency" table in Appendix E of the adopted Local Coastal Plan provides that the Timberland Production and Resources and Rural Development zoning districts are consistent with both and

the Resources and Rural Development Land Use Designation of the General Plan and the Timber Land Use Designation of the Local Coastal Plan. The proposed zone change is being undertaken to ensure consistency with the Local Coastal Plan and land use maps is consistent with the purpose and intent of the Coastal Act.

3. Placing Robert Mann's 0.7 acres of land located at 15600 Highway 1, Jenner (APN 109-170-032, -033), into timberland production zoning and TPZ Assessment meets the criteria of Government Code Section 51104(f) and (g) because the land contains the soils and climate capable of producing timber and is contiguous to timberland already zoned as timberland production and therefore is consistent with Government Code Sections 51113.5 and 51141.
4. The proposed zone change is non-substantive in nature and will not change the development potential that would otherwise be allowed by the Local Coastal Plan.
5. The project is exempt from the California Environmental Quality Act under the General Rule, Section 15061(b)(3), as it can be seen with certainty that the project will not have a significant effect on the environment because the proposed change to the Official Zoning Database and Coastal Zoning Database consists of a technical correction that removes split zoning resulting from a prior project approval and further, that the proposed change will not result in any physical change to land or increase development potential; and

Be It Further Resolved, that the Board authorizes the County Assessor to assign TPZ Assessment to Robert Mann's land located at 15600 Highway 1, Jenner; APN 109-170-032, and -033; Supervisorial District No. 5.

Be It Further Resolved that the Board authorizes staff to submit the zone change to the Coastal Zoning Database to the California Coastal Commission for certification.

Be It Further Resolved, that the County of Sonoma will carry out the above Sonoma County Local Coastal Program Amendment in a manner fully consistent with the California Coastal Act (Coastal Act Section 30510) and that the amendment will take place automatically upon Coastal Commission certification.

Be It Further Resolved, that the Board of Supervisors designates the Clerk of the Board as the custodian of the documents and other material which constitute the record of proceedings upon which the decision herein is based, including the original executed Contract and Land Conservation Plan. These documents may

Resolution #

Date: November 16, 2018

Page 4

be found at the office of the Clerk of the Board, 575 Administration Drive, Room 100-A, Santa Rosa, California 95403.

Supervisors:

Gorin:

Rabbitt:

Zane:

Hopkins:

Gore:

Ayes:

Noes:

Absent:

Abstain:

So Ordered.

ORDINANCE NO. ()

AN ORDINANCE OF THE BOARD OF SUPERVISORS OF THE COUNTY OF SONOMA, STATE OF CALIFORNIA, AMENDING THE OFFICIAL ZONING DATABASE AND COASTAL ZONING DATABASE OF THE COUNTY OF SONOMA, ADOPTED BY REFERENCE BY SECTION 26-02-110 OF THE SONOMA COUNTY CODE, BY RECLASSIFYING CERTAIN REAL PROPERTY FROM THE RRD (RESOURCES AND RURAL DEVELOPMENT), B6 160-ACRE DENSITY / RRD (RESOURCES AND RURAL DEVELOPMENT) CC (COASTAL ZONE) B6 160/640-ACRE DENSITY/ACRES MINIMUM, RC 50/50 (RIPARIAN CORRIDOR WITH 50-FOOT SETBACKS), RC 100/50 (RIPARIAN CORRIDOR WITH 100-FOOT AND 50-FOOT SETBACKS), SR (SCENIC RESOURCES) TO TP (TIMBERLAND PRODUCTION), B6 160-ACRE DENSITY / TP (TIMBERLAND PRODUCTION) CC (COASTAL ZONE) B6 160/640-ACRE DENSITY/ACRES MINIMUM, RC 50/50 (RIPARIAN CORRIDOR WITH 50-FOOT SETBACKS), RC 100/50 (RIPARIAN CORRIDOR WITH 100-FOOT AND 50-FOOT SETBACKS), SR (SCENIC RESOURCES) ZONING DISTRICT FOR 0.7 ACRES LOCATED AT 15600 HIGHWAY 1, JENNER; APN 109-170-032, AND -033.

The Board of Supervisors of the County of Sonoma, State of California, ordains as follows:

Section I. The Official Zoning Database (OZD) and Coastal Zoning Database (CZD) of the County, adopted by reference by Section 26-02-110 of the Sonoma County Code, is amended by reclassifying the following real property from the RRD (Resources and Rural Development), B6 160-acre density / RRD (Resources and Rural Development) CC (Coastal Zone) B6 160/640-acre density/acres minimum, RC 50/50 (Riparian Corridor with 50-foot setbacks), RC 100/50 (Riparian Corridor with 100-foot and 50-foot setbacks), SR (Scenic Resources) to the TP (Timberland Production) B6 160-acre density / TP (Timberland Production) CC (Coastal Zone) B6 160/640-acre density/acres minimum, RC 50/50 (Riparian Corridor 50-foot setbacks), RC 100/50 (Riparian Corridor with 100-foot and 50-foot setbacks), SR (Scenic Resources) district, for 0.7 acres located at located at 15600 Highway 1, Jenner; APN 109-170-032, and -033. File No. ZCE18-0011. The Director of the Permit and Resource Management Department is directed to reflect this amendment in the OZD and the CZD of the County as shown on the attached Exhibit A.

Section II. The Proposed Project is exempt from the California Environmental Quality Act (CEQA) pursuant to Section 15061(b)(3) of the State CEQA guidelines as it can be seen with certainty that the project will have no significant effect on the environment since the project consists of technical corrections and minor changes that remove split zoning resulting from a prior project approval.

Section III. The Board of Supervisors authorizes the County Assessor to assign Timber Production Zone (TPZ) Assessment to Robert Mann's land located at 15600 Highway 1, Jenner; APN 109-170-032, and -033.

Section IV. If any section, subsection, sentence, clause, or phrase of this Ordinance is for any reason held to be unconstitutional or invalid, such decision shall not affect the validity of the remaining portion of this Ordinance. The Board of Supervisors hereby declares that it would have passed this Ordinance and every section, subsection, sentence, clause or phrase thereof irrespective of the fact that any one or more sections, subsections, sentences, clauses or phrases be declared unconstitutional or invalid.

SECTION V: This Ordinance shall be and the same is hereby declared to be in full force and effect automatically from and after thirty (30) days following California Coastal Commission certification, and shall be carried out in a manner fully consistent with the California Coastal Act. This item involves an amendment to the Local Coastal Program and is not effective until and unless approved by the California Coastal Commission.

SECTION VI: This Ordinance shall be published once before the expiration of fifteen (15) days after said passage, with the names of the Supervisors voting for or against the same, in a newspaper of general circulation, published in the County of Sonoma, State of California.

In regular session of the Board of Supervisors of the County of Sonoma, introduced on the ___ day of ___, 2018, and finally passed and adopted this ___ day of ___, 2018, on regular roll call of the members of said Board by the following vote:

SUPERVISORS:

Gorin: ___ Rabbitt: ___ Zane: ___ Hopkins: ___ Gore: ___

Ayes: _____ Noes: _____ Absent: _____ Abstain: _____

WHEREUPON, the Chair declared the above and foregoing Ordinance duly adopted and

SO ORDERED.

James Gore
Chair, Board of Supervisors
County of Sonoma

ATTEST:

Sheryl Bratton,
Clerk of the Board of Supervisors

Existing Zoning

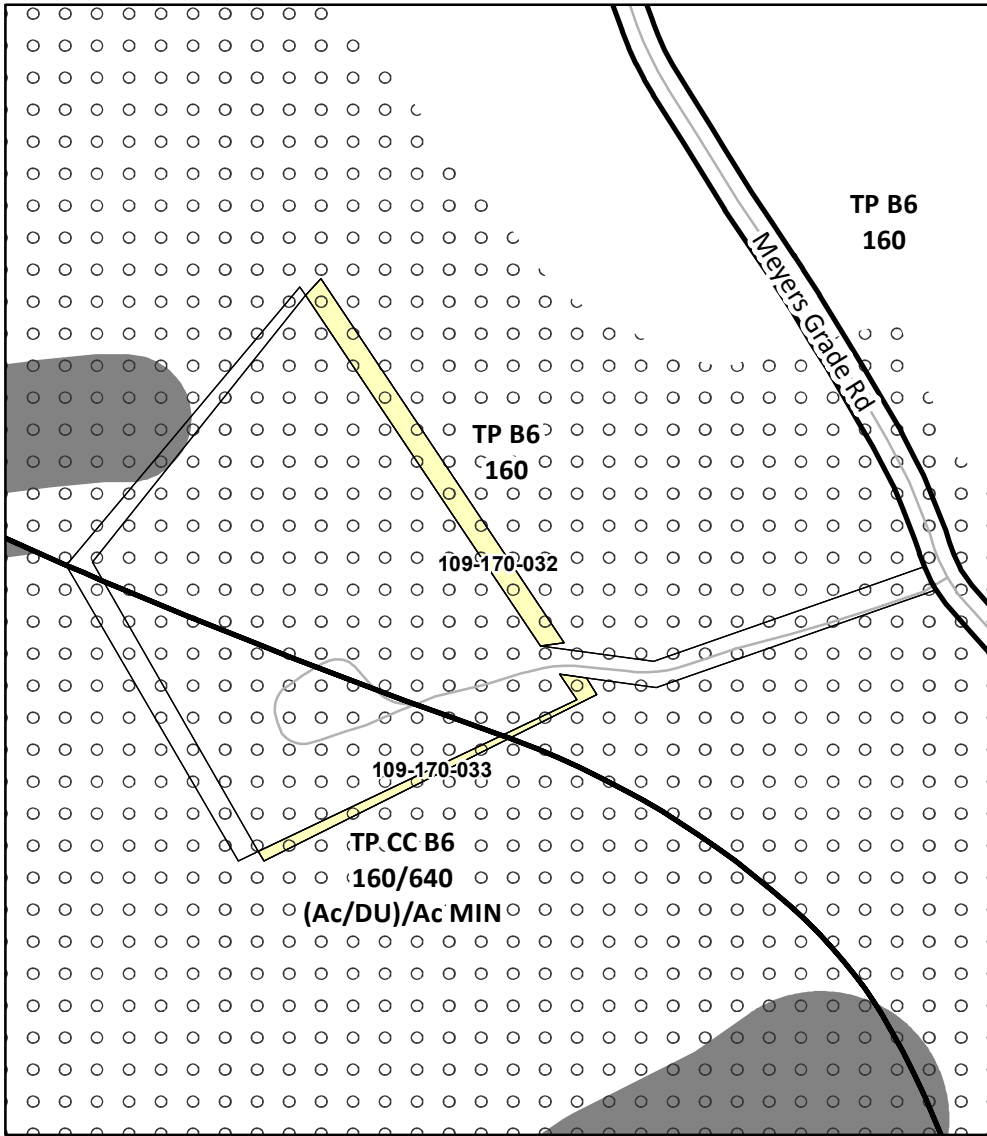

Proposed Zoning

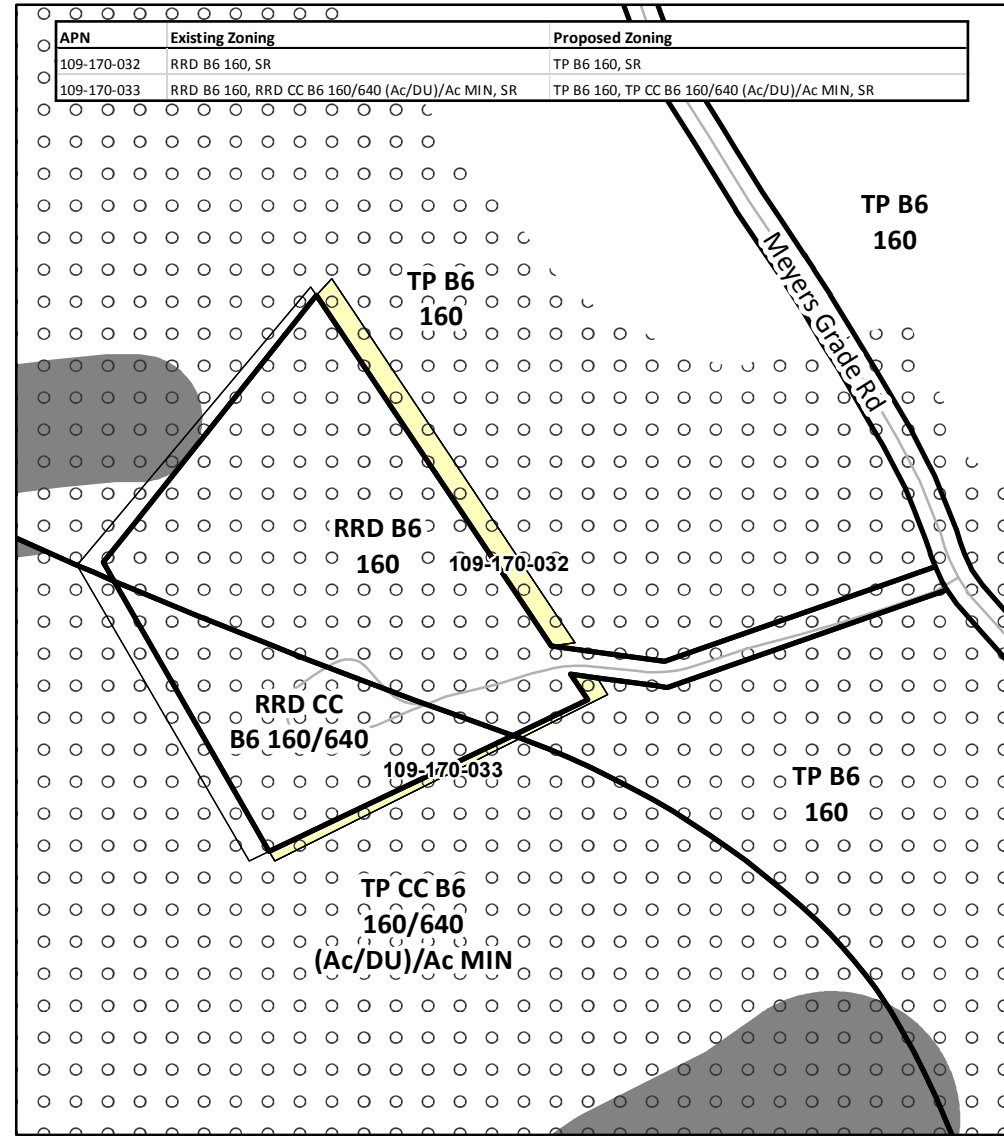

APN	Existing Zoning	Proposed Zoning
109-170-032	RRD B6 160, SR	TP B6 160, SR
109-170-033	RRD B6 160, RRD CC B6 160/640 (Ac/DU)/Ac MIN, SR	TP B6 160, TP CC B6 160/640 (Ac/DU)/Ac MIN, SR

Base Map Data

- Subject Parcel
- Parcel
- Basezoning by Area
- Street

Zoning Combining Districts

- RC Riparian Corridor
- SR Scenic Resource

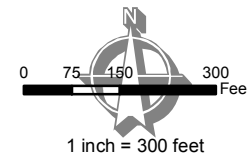

FILE: ZCE18-0011-B
 APNs: 109-170-032, & -033
 Ordinance No. TBD
 Sectional District Map No. TBD

Permit and Resource Management Department
 Project Review Section
 2550 Ventura Avenue, Santa Rosa, CA 95403
 (707) 565-1965 Fax (707) 565-1103



Sonoma County Planning Commission **STAFF REPORT**

Sonoma County Permit and Resource Management Department

2550 Ventura Avenue, Santa Rosa, CA 95403
(707) 565-1900 FAX (707) 565-1103

FILE: ZCE18-0011
DATE: October 4, 2018
TIME: 1:05pm
STAFF: Hannah Spencer

Board of Supervisors hearing will be held at a later date and will be noticed at that time.

SUMMARY

Applicants: Tom Berry and County of Sonoma

Owners: Rachel Curran and Brian Wares
Robert Mann

Location: 14500 Meyers Grade Rd, Jenner; APNs 109-170-034 and -035.
15600 Highway 1, Jenner; APNs 109-170-032 and -033.

Subject: Technical Corrections to the Official Zoning Database and Coastal Zoning Database.

PROPOSAL: Amend the Official Zoning Database and Coastal Zoning Database to correct minor technical errors resulting from zoning map updates and prior approval of a noncontroversial lot line adjustment.

Environmental Determination: Categorically Exempt, CEQA Guidelines Section 15061(b)(3)

General Plan: Resources and Rural Development 160 and 640 acre densities

Specific/Area Plan: None
Land Use: N/A

Ordinance Reference: Sections 26-02-110 and 26-02-130

Zoning: TP (Timberland Production), B6 160 / TP (Timberland Production) CC (Coastal Zone) B6 160/640 (Ac/DU)/AcMIN, RC (Riparian Corridor) 50-foot and 100-foot setbacks, SR (Scenic Resources)

Land Conservation Contract: N/A

RECOMMENDATION: Adopt the Resolution recommending that the Board of Supervisors approve the proposed amendments to the Official Zoning Database as technical corrections.

ANALYSIS

Executive Summary:

Permit Sonoma periodically identifies zoning and/or land use discrepancies to improve and maintain the accuracy of the Official Zoning Database (OZD) and Coastal Zoning Database. Any discrepancies and minor zoning and land use amendments are then brought forward as technical corrections to improve the databases. While processing PRMD File No. ZCE18-0011, staff discovered zoning discrepancies that resulted from transcribing zoning maps during the 1991 and 1993 zoning map updates. These zoning discrepancies affect a total of 9.73 acres of land on two properties, located at 15600 Highway 1 and 14500 Meyers Grade Rd, Jenner. Without realizing the zoning discrepancies, Permit Sonoma approved a lot line adjustment for the two parcels in 2016, which resulted in inaccurate split zoning for both parcels. The purpose of this application is to correct the County's errors made in the 1990's and to complete minor zone changes to correct zoning discrepancies resulting from the 2016 lot line adjustment. This application does not propose any changes to General Plan or Local Coastal Plan land use designations.

Background:

While processing PRMD File No. ZCE18-0011, staff discovered zoning discrepancies that affect 0.7 acres of Robert Mann's 386.98-acre parcel located at 15600 Highway 1 (APN 109-170-032, -033, -036) and his neighbor's 9.03-acre parcel (owned by Rachel Curran and Brian Wares, "the Currans") located at 14500 Meyers Grade Road (APN 109-170-034, -035). Historic zoning maps and Permit Sonoma records show the County inadvertently zoned the Currans' 9.03-acre parcel in 1991, from the A1 (Primary Agriculture) / AP (Primary Agriculture) base zoning district to A1 (Primary Agriculture) / TP (Timberland Production) base zoning. The A1 (Primary Agriculture) zoning district applied to the Currans' portion of land that is outside of the Local Coastal Plan and, the AP (Primary Agriculture) zoning district applied to the Currans' portion of land that is within the Local Coastal Plan.

As part of the implementation of the 1989 General Plan, the Board of Supervisors adopted Ordinance No. 4643 rezoning agricultural and resource lands to match the new General Plan designations. In 1993, the County updated zoning maps to reflect these new land use and zoning designations. During this zoning map update, the County inadvertently zoned the Currans' entire parcel as TP (Timberland Production) base zoning.

Believing the Currans' land to be correctly zoned for timberland production, the County approved a lot line adjustment (file #LLA16-0023) between Robert Mann's parcel and the Currans' parcel, in which 0.7 acres of land was exchanged. According to staff's review of historic zoning maps and consultation with the Assessor's Office, Robert Mann's parcel is correctly zoned TP (Timberland Production) and has Timber Preserve Zone (TPZ) assessment value; yet the Curran's land is incorrectly zoned TP (Timberland Production) and therefore did not receive TPZ assessment value until the lot line adjustment went into effect. Further in the staff report, it provides information and history of timberland production zoning versus TPZ assessment value.

Due to the County's inadvertent rezoning of the Curran's parcel in the 1990's, the 2016 lot line adjustment resulted in the following:

- Robert Mann received 0.7 acres of land from the Currans that is incorrectly zoned TP (Timberland Production) and therefore does not have TPZ assessment. The Assessor assigned his property three Assessor Parcel Numbers with one APN receiving TPZ assessment.

- The Currans received 0.7 acres of Robert Mann's land that is correctly zoned TP (Timberland Production) with TPZ Assessment. The Assessor assigned their property two Assessor Parcel Numbers with one APN receiving TPZ assessment.

Robert Mann wishes for his entire property to remain in Timberland Production zoning and the TPZ assessment program. The Currans wish to correct their property's inaccurate zoning designation by rezoning to Resources and Rural Development. Both landowners would like their properties restored to a single APN. The proposed changes will allow the Assessor's Office to correctly assign TPZ assessment to Robert Mann's property and assign each property a single APN.

Project Description:

The primary purpose of the proposed changes is to correct technical errors in zoning that resulted from the 1991 and 1993 zoning map updates. Minor zone changes are also included in the project to remove split zoning resulting from a 2016 lot line adjustment approval. These proposed changes involve phasing a small portion of land out of Timberland Production zoning and placing an equal amount of land into Timberland Production zoning. Timberland Production zoning imposes additional land use restrictions for the purpose of conserving and protecting forestland and in exchange, the landowner receives a property tax reduction.

The proposed changes, as described below, will not result in any changes to the General Plan or Local Coastal Plan land use designations. The parcels are designated Resources and Rural Development which is consistent with Timberland Production and Resources and Rural Development zoning districts. No changes to combining zones are needed. The parcels will remain with a split density of 160 acres per dwelling unit and 160/640 (acres per dwelling unit)/acres minimum and combining zones of CC (Coastal Zone), RC (Riparian Corridor) 50-foot and 100-foot setbacks, SR (Scenic Resources).

- A. Amendment to Zoning – Correcting zoning errors.** Correct inadvertent errors made to the zoning designation for property located at 14500 Meyers Grade Rd (APN 109-170-034) and property located at 15600 Highway 1 (APN 109-170-032 and -033) during the 1991 and 1993 zoning map updates, by rezoning APN 109-170-032, -033, and -034 from the TP (Timberland Production) base zoning district to the RRD (Resources and Rural Development) base zoning district.
- B. Amendments to Zoning – Minor zone changes.** Implement minor zone changes to remove split zoning resulting from a prior lot line adjustment approval. In 2016, two properties located at 14500 Meyers Grade Rd and 15600 Highway 1 in Jenner exchanged 0.7 acres of land via Lot Line Adjustment file No. LLA16-0023. Due to inadvertent zoning errors that occurred in 1991 and 1993, the lot line adjustment resulted in split zoning for each parcel.
- For the Curran's property located at 14500 Meyers Grade Rd**, initiate a rezone for 0.7 acres of land identified as APN109-170-035, to the RRD (Resources and Rural Development) base zoning district. Upon approval of the rezone, the County will record a Resolution authorizing TPZ Phase-Out for APN109-170-035. Effective 10 years from the date of approval, the Official Zoning Database will identify APN 109-170-035 with base zoning of RRD (Resources and Rural Development). This zone change will result in the Curran's entire property assigned to the RRD (Resources and Rural Development) base zoning district.
 - For Robert Mann's property located at 15600 Highway 1**, rezone 0.7 acres of land identified as APN109-170-032 and -033 from the RRD (Resources and Rural Development) base zoning district to the TP (Timberland Production) base zoning district and record a Resolution authorizing TPZ Assessment for this land. This zone change will

result in Robert Mann's entire property assigned to the TP (Timberland Production) base zoning district with TPZ Assessment.

Site Characteristics:

The Curran's property located at 14500 Meyers Grade Rd is 9.03 acres in size and contains a residence, accessory structures and corrals. Their property is accessed from Meyers Grade Rd and is entirely surrounded by Robert Mann's property. Robert Mann's property located at 15600 Highway 1 is 386.98 acres in size and remains undeveloped. Mann's land is primarily covered in conifer forest and coastal grasslands. Both properties straddle the border of the Coastal Zone about 5 miles north of Jenner.

Surrounding Land Use and Zoning:

North: Parcels ranging from 3 acres to over 400 acres in size; base zoning is Timberland Production and Resources and Rural Development with allowable densities of 160 and 640 acres per dwelling unit.

East: Parcel of 425 acres in size; base zoning is Timberland Production with an allowable density of 160 and 640 acres per dwelling unit.

West: Parcels ranging from 385 acres to over 700 acres in size; base coastal zoning is Land Extensive Agriculture and Timberland Production with allowable densities of 160 and 640 acres per dwelling unit.

South: Parcels ranging from 8 acres to over 200 acres in size; base coastal zoning is Timberland Production with allowable densities of 160 and 640 acres per dwelling unit.

DISCUSSION OF ISSUES

Issue #1: General Plan Consistency

The primary purpose for the proposed changes to zoning is to ensure consistency between the General Plan and other planning documents and ordinances. Correcting zoning to accurately reflect applicable base zoning districts based on property boundaries eliminates split zoning and ensures the integrity and reliability of the information on which both the public and staff rely. Further, the zoning corrections and amendments do not result in changes to the Resources and Rural Development Land Use Designation of the General Plan nor to the Resources and Rural Development Land Use Designation of the Local Coastal Plan.

Issue #2: Zoning

As part of the implementation of the 1989 General Plan, the Board of Supervisors adopted Ordinance No. 4643 rezoning agricultural and resource lands to match the new General Plan land use designations. As a result, lands in the remote coastal mountain ranges previously zoned as A1 (Primary Agriculture) and AP (Primary Agriculture) and, either contained no agriculture, or were not capable of supporting an economically viable agricultural enterprise (due to constraints such as parcel size, soils, and water availability), were rezoned to the RRD (Resources and Rural Development) zoning district.

The historic zoning issues and site constraints listed below indicate the Currans' parcel should've been zoned RRD (Resources and Rural Development) during the zoning map updates resulting from Ordinance No. 4643.

- Prior to zoning errors made by the County, the parcel was zoned A1 (Primary Agriculture) / AP (Primary Agriculture).
- The parcel is located in the remote coastal mountain ranges of Sonoma County.
- The parcel is located in a Groundwater Availability Class 4 (Water Scarce Area).
- The parcel is less than 10 acres in size and likely too small to support an economically viable agricultural enterprise.

The Currans' property is surrounded by land zoned for timberland production. The nearest parcel that is zoned for resources and rural development is located approximately 1,200 feet to the northeast. Therefore, rezoning the Currans' land to the RRD (Resources and Rural Development) base zoning district would result in spot zoning. The County of Sonoma has attempted to implement a comprehensive land use plan through its Zoning Ordinance and spot zoning is generally considered undesirable. However, in this case spot zoning would be necessary because the Currans' property was inadvertently zoned for timberland production zoning (as discussed above) and does not meet the criteria for placing land into the TPZ Assessment program for timberland production zoned lands.

Although rezoning the Currans' property would result in spot zoning, rezoning this land to the Resources and Rural Development base zoning district would be consistent with the property's General Plan and Local Coastal Plan land use designation of Resources and Rural Development.

Issue #2: Timberland Production Zoning

The purpose of the Timberland Production zoning district is to provide for the conservation and protection of land capable of producing timber and forest products. Landowners receive reduced property taxes until timber harvest and a yield tax is then imposed. A TPZ (Timberland Preserve Zone) is a 10-year restriction on the use of land to the growing and harvesting of timber and compatible uses approved by the County in return for property tax benefits. All timberland production-zoned land is required to be located within a TPZ. Thus, all timberland production-zoned land receives TPZ assessment. Robert Mann's property was zoned TP (Timberland Production) shortly after the State passed the Forest Taxation Reform Act of 1976. Since the Timberland Productivity Act of 1982, his property has also been included in a TPZ.

To rezone land out of timberland production, Government Code Sections 51120 and 51140 requires the landowner submit a request to phase-out of timberland production zoning and the County record a Resolution approving the rezone and authorizing TPZ Phase-Out. The new zoning becomes effective 10 years from the date of approval of the rezone. Property taxes increase immediately upon approval, and continue to increase annually and incrementally over the ensuing 10 years that the TPZ restrictions remain in place.

To place land into timberland production zoning, Government Code Sections 51113.5 and 51104 (f) and (g) require the landowner submit a petition to place the land in timberland production zoning and demonstrate the land is capable of producing timber. The land must also be contiguous to timberland already zoned as timberland production. Upon approval of the rezone, Government Code Section 51141 requires recordation of a Resolution approving the rezone and authorizing the land be placed in TPZ Assessment.

On May 23, 2018, staff consulted with Cal Fire's Forester for the Sonoma-Lake-Napa Unit on the technical errors that resulted from zoning discrepancies affecting Robert Mann's property and the Currans' property. Cal Fire concurred with Permit Sonoma's proposal to make technical zoning

corrections to both properties. Normally, an immediate phase out of timberland zoning requires a timberland conversion permit that would be obtained from Cal Fire. However, Cal Fire is not requiring the Currans' obtain a timberland conversion permit due to the fact that that it was mistakenly zoned for timberland production. Cal Fire also concurred with Permit Sonoma's proposal to include Robert Mann's .7 acres into the timberland production zoning and TPZ assessment program, as there would be no net change in the TPZ acres.

STAFF RECOMMENDATION

Staff recommends the Planning Commission adopt the attached Resolutions recommending that the Board of Supervisors approve the proposed Zone Changes as technical corrections, authorizing to place Robert Mann's land into TPZ assessment, and authorizing the Currans' land to phase out of TPZ assessment.

FINDINGS FOR RECOMMENDED ACTION

1. The proposed amendments are necessary to correct errors and remove split zoning in the Official Zoning Database and Coastal Zoning Database that resulted from inadvertent rezoning in 1991 and 1993 and prior project approval of LLA16-0023, to ensure the accuracy and reliability of the planning information on which the public relies.
2. The proposed amendments are consistent and compatible with the Sonoma County General Plan and Local Coastal Plan in that the changes include technical corrections to zoning that ensure the integrity and reliability of the information on which both the public and staff rely. Further, the zoning corrections do not result in changes to the Resources and Rural Development Land Use Designation of the General Plan nor to the Resources and Rural Development Land Use Designation of the Local Coastal Plan.
3. Authorizing 0.7 acres of the Currans' land located at 14500 Meyers Grade Road, Jenner (APN 109-170-035) to phase out of TPZ Assessment is consistent with Government Code Sections 51120 and 51140.
4. Placing Robert Mann's 0.7 acres of land located at 15600 Highway 1, Jenner (APN 109-170-032, -033), into timberland production zoning and TPZ Assessment meets the criteria of Government Code Section 51104(f) and (g) because the land contains the soils and climate capable of producing timber and is contiguous to timberland already zoned as timberland production and therefore is consistent with Government Code Sections 51113.5 and 51141.
5. The proposed Amendments are exempt from the California Environmental Quality Act ("CEQA") under Section 15061(b)(3), as it can be seen with certainty that the project will have no significant effect on the environment since the project consists of technical corrections and minor changes that resolve zoning errors and remove split zoning resulting from a prior project approval.

LIST OF ATTACHMENTS

- EXHIBIT A: Draft Ordinance and Exhibit correcting zoning errors made by County in 1991 & 1993
- EXHIBIT B: Draft Ordinance and Exhibit phasing Currans' land out of TP zoning to remove split zoning

- EXHIBIT C: Draft Ordinance and Exhibit placing Robert Mann's land into TP zoning to remove split zoning
 - EXHIBIT D: Vicinity Map
 - EXHIBIT E: General Plan Land Use Map
 - EXHIBIT F: Assessor's Parcel Map (Current and pre-2016 lot line adjustment)
 - EXHIBIT G: Timberland zoning and TPZ Government Code References
 - EXHIBIT H: Draft Resolution correcting zoning errors made by County in 1991 & 1993
 - EXHIBIT I: Draft Resolution phasing Currans' land out of TP zoning to remove split zoning
 - EXHIBIT J: Draft Resolution placing Robert Mann's land into TP zoning to remove split zoning
-

ORDINANCE NO. ()

AN ORDINANCE OF THE BOARD OF SUPERVISORS OF THE COUNTY OF SONOMA, STATE OF CALIFORNIA, AMENDING THE OFFICIAL ZONING DATABASE AND COASTAL ZONING DATABASE OF THE COUNTY OF SONOMA, ADOPTED BY REFERENCE BY SECTION 26-02-110 OF THE SONOMA COUNTY CODE, BY RECLASSIFYING CERTAIN REAL PROPERTY FROM THE TP (TIMBERLAND PRODUCTION), B6 160-ACRE DENSITY / TP (TIMBERLAND PRODUCTION) CC (COASTAL ZONE) B6 160/640-ACRE DENSITY/ACRES MINIMUM, RC 50/50 (RIPARIAN CORRIDOR WITH 50-FOOT SETBACKS), RC 100/50 (RIPARIAN CORRIDOR WITH 100-FOOT AND 50-FOOT SETBACKS), SR (SCENIC RESOURCES) TO THE RRD (RESOURCES AND RURAL DEVELOPMENT), B6 160-ACRE DENSITY / RRD (RESOURCES AND RURAL DEVELOPMENT) CC (COASTAL ZONE) B6 160/640-ACRE DENSITY/ACRES MINIMUM, RC 50/50 (RIPARIAN CORRIDOR WITH 50-FOOT SETBACKS), RC 100/50 (RIPARIAN CORRIDOR WITH 100-FOOT AND 50-FOOT SETBACKS), SR (SCENIC RESOURCES) ZONING DISTRICT FOR 9.03 ACRES OF LAND LOCATED AT 15600 HIGHWAY 1 AND 14500 MEYERS GRADE ROAD, JENNER; APN 109-170-032, -033, AND -034.

The Board of Supervisors of the County of Sonoma, State of California, ordains as follows:

Section I. The Official Zoning Database (OZD) and Coastal Zoning Database (CZD) of the County, adopted by reference by Section 26-02-110 of the Sonoma County Code, are amended by reclassifying the following real property from the TP (Timberland Production), B6 160-acre density / TP (Timberland Production) CC (Coastal Zone) B6 160/640-acre density/acres minimum, RC 50/50 (Riparian Corridor with 50-foot setbacks), RC 100/50 (Riparian Corridor with 100-foot and 50-foot setbacks), SR (Scenic Resources) to the RRD (Resources and Rural Development) B6 160-acre density / RRD (Resources and Rural Development) CC (Coastal Zone) B6 160/640-acre density/acres minimum, RC 50/50 (Riparian Corridor 50-foot setbacks), RC 100/50 (Riparian Corridor with 100-foot and 50-foot setbacks), SR (Scenic Resources) district, for 9.03 acres of land located at located at 15600 Highway 1 and 14500 Meyers Grade Road, Jenner; APN 109-170-032, -033, and -034. File No. ZCE18-0011. The Director of the Permit and Resource Management Department is directed to reflect this amendment in the OZD and the CZD of the County as shown on the attached Exhibit A.

Section II. The Proposed Project is exempt from the California Environmental Quality Act (CEQA) pursuant to Section 15061(b)(3) of the State CEQA guidelines as it can be seen with certainty that the project will have no significant effect on the environment since the project consists of a technical corrections and minor changes that resolve inadvertent zoning errors.

Section III. If any section, subsection, sentence, clause, or phrase of this Ordinance is for any reason held to be unconstitutional or invalid, such decision shall not affect the

validity of the remaining portion of this Ordinance. The Board of Supervisors hereby declares that it would have passed this Ordinance and every section, subsection, sentence, clause or phrase thereof irrespective of the fact that any one or more sections, subsections, sentences, clauses or phrases be declared unconstitutional or invalid.

SECTION IV: This Ordinance shall be and the same is hereby declared to be in full force and effect automatically from and after thirty (30) days following California Coastal Commission certification, and shall be carried out in a manner fully consistent with the California Coastal Act. This item involves an amendment to the Local Coastal Program and is not effective until and unless approved by the California Coastal Commission.

SECTION V: This Ordinance shall be published once before the expiration of fifteen (15) days after said passage, with the names of the Supervisors voting for or against the same, in a newspaper of general circulation, published in the County of Sonoma, State of California.

In regular session of the Board of Supervisors of the County of Sonoma, introduced on the ___ day of ___, 2018, and finally passed and adopted this ___ day of ___, 2018, on regular roll call of the members of said Board by the following vote:

SUPERVISORS:

Gorin: ___ Rabbitt: ___ Zane: ___ Hopkins: ___ Gore: ___

Ayes: ___ Noes: ___ Absent: ___ Abstain: ___

WHEREUPON, the Chair declared the above and foregoing Ordinance duly adopted and

SO ORDERED.

James Gore
Chair, Board of Supervisors
County of Sonoma

ATTEST:

Sheryl Bratton,
Clerk of the Board of Supervisors

Existing Zoning

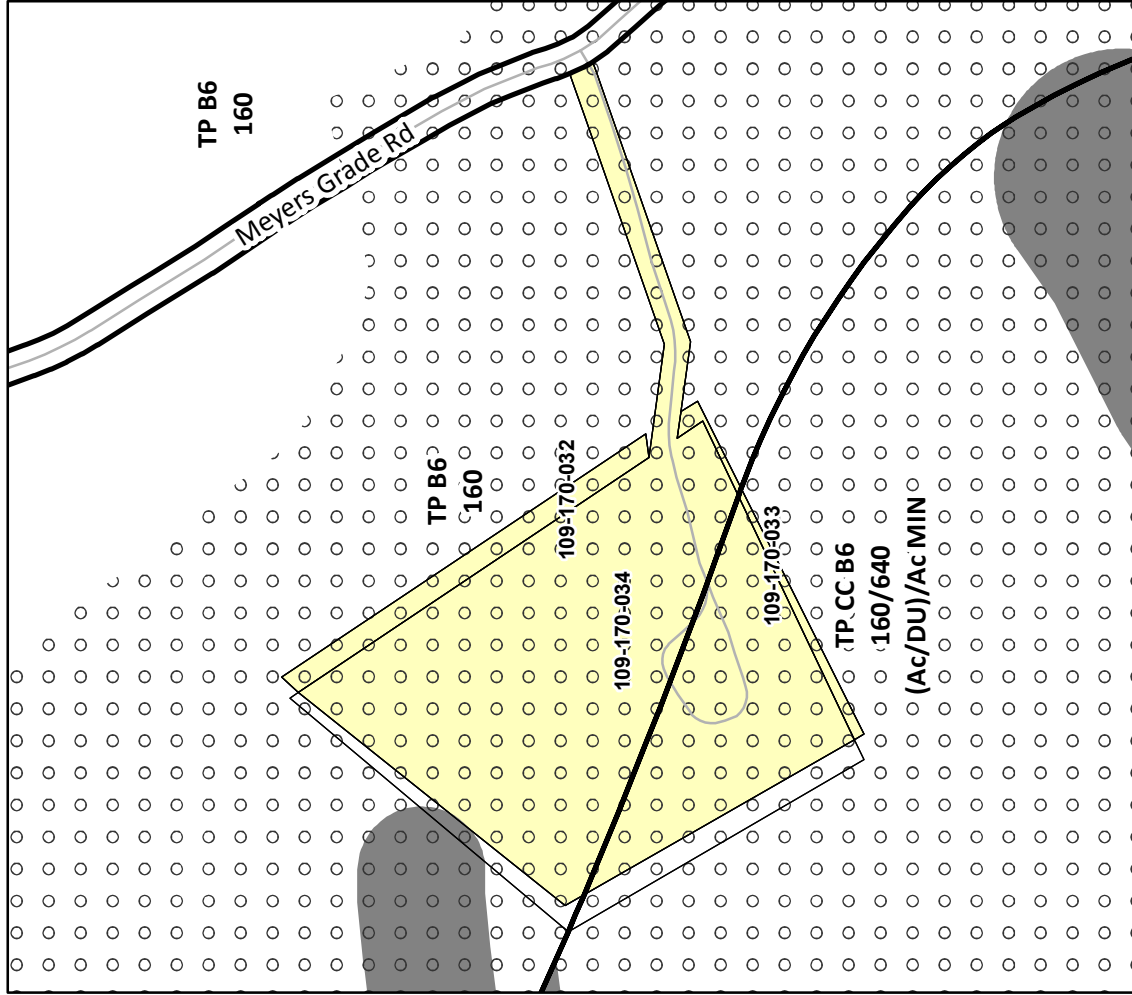

Proposed Zoning

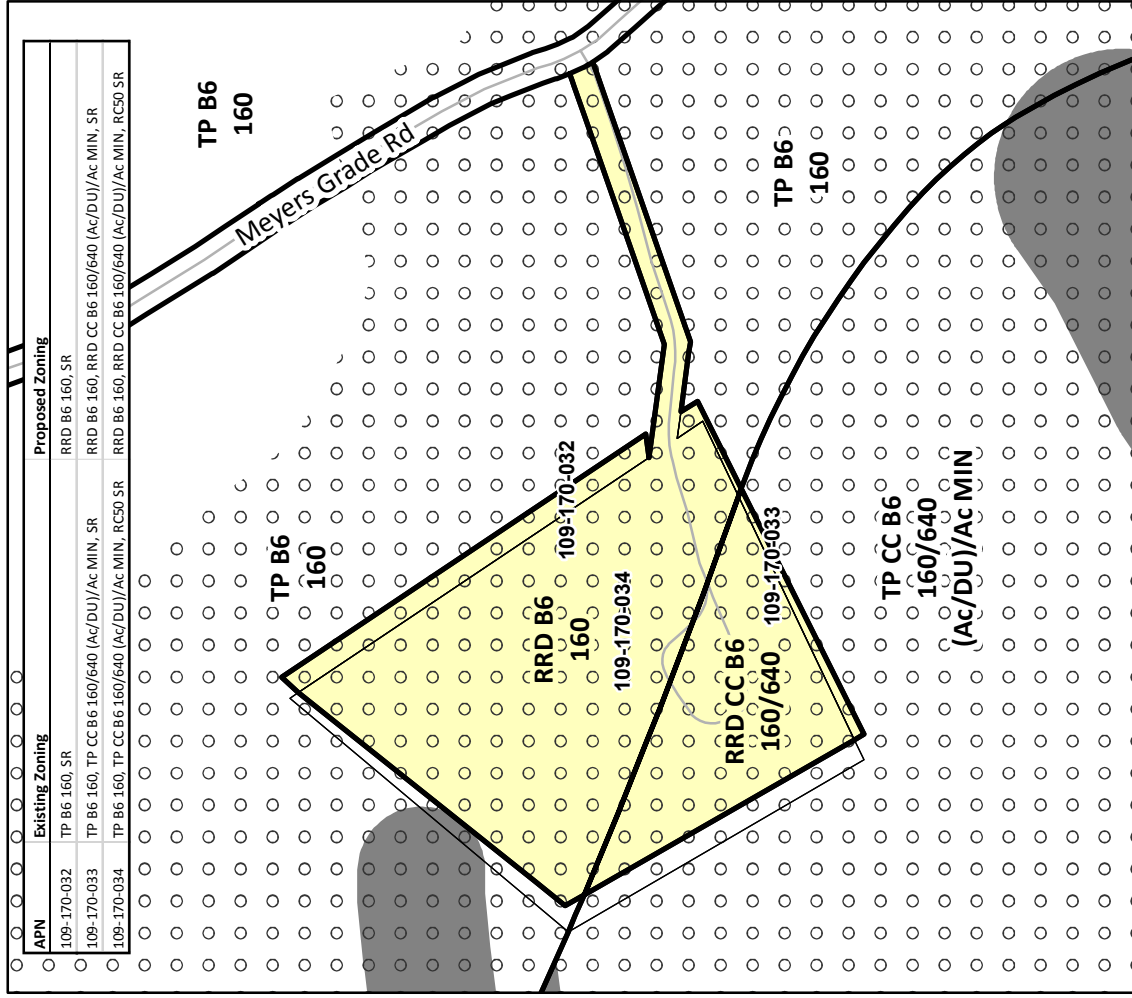

Zoning Combining Districts

- RC Riparian Corridor
- SR Scenic Resource

Base Map Data

- Attachment
- Subject Parcel
- Parcel
- Base zoning by Area
- Street

FILE: ZCE18-0011-A
 APNs: 109-170-032, -033, & -034
 Ordinance No. TBD
 Sectional District Map No. TBD

1 inch = 300 feet

Permit and Resource Management Department
 Project Review Section
 2550 Ventura Avenue, Santa Rosa, CA 95403
 (707) 565-1965 Fax (707) 565-1103

ORDINANCE NO. ()

AN ORDINANCE OF THE BOARD OF SUPERVISORS OF THE COUNTY OF SONOMA, STATE OF CALIFORNIA, AMENDING THE OFFICIAL ZONING DATABASE AND COASTAL ZONING DATABASE OF THE COUNTY OF SONOMA, ADOPTED BY REFERENCE BY SECTION 26-02-110 OF THE SONOMA COUNTY CODE, BY RECLASSIFYING CERTAIN REAL PROPERTY FROM THE TP (TIMBERLAND PRODUCTION), B6 160-ACRE DENSITY / TP (TIMBERLAND PRODUCTION) CC (COASTAL ZONE) B6 160/640-ACRE DENSITY/ACRES MINIMUM, RC 50/50 (RIPARIAN CORRIDOR WITH 50-FOOT SETBACKS), RC 100/50 (RIPARIAN CORRIDOR WITH 100-FOOT AND 50-FOOT SETBACKS), SR (SCENIC RESOURCES) TO THE RRD (RESOURCES AND RURAL DEVELOPMENT), B6 160-ACRE DENSITY / RRD (RESOURCES AND RURAL DEVELOPMENT) CC (COASTAL ZONE) B6 160/640-ACRE DENSITY/ACRES MINIMUM, RC 50/50 (RIPARIAN CORRIDOR WITH 50-FOOT SETBACKS), RC 100/50 (RIPARIAN CORRIDOR WITH 100-FOOT AND 50-FOOT SETBACKS), SR (SCENIC RESOURCES) ZONING DISTRICT FOR 0.7 ACRES LOCATED AT 14500 MEYERS GRADE ROAD, JENNER; APN 109-170-035.

The Board of Supervisors of the County of Sonoma, State of California, ordains as follows:

Section I. The Official Zoning Database (OZD) and Coastal Zoning Database (CZD) of the County, adopted by reference by Section 26-02-110 of the Sonoma County Code, are amended by reclassifying the following real property from the TP (Timberland Production), B6 160-acre density / TP (Timberland Production) CC (Coastal Zone) B6 160/640-acre density/acres minimum, RC 50/50 (Riparian Corridor with 50-foot setbacks), RC 100/50 (Riparian Corridor with 100-foot and 50-foot setbacks), SR (Scenic Resources) to the RRD (Resources and Rural Development) B6 160-acre density / RRD (Resources and Rural Development) CC (Coastal Zone) B6 160/640-acre density/acres minimum, RC 50/50 (Riparian Corridor 50-foot setbacks), RC 100/50 (Riparian Corridor with 100-foot and 50-foot setbacks), SR (Scenic Resources) district, for 0.7 acres of land located at located at 14500 Meyers Grade Road, Jenner; APN 109-170-035. File No. ZCE18-0011. The Director of the Permit and Resource Management Department is directed to reflect this amendment in the OZD and the CZD of the County as shown on the attached Exhibit A.

Section II. The Proposed Project is exempt from the California Environmental Quality Act (CEQA) pursuant to Section 15061(b)(3) of the State CEQA guidelines as it can be seen with certainty that the project will have no significant effect on the environment since the project consists of a technical correction and minor change that removes split zoning resulting from a prior project approval.

Section III. On the date 10 years from the effective date of the ordinance, the Official Zoning Database and Coastal Zoning Database will identify 0.7 acres of land located at 14500 Meyers Grade Road, Jenner (APN 109-170-035), with a RRD (Resources and

Rural Development) base zoning district. As part of the rezone, the Board of Supervisors approve the County Assessor to phase APN 109-170-035 out of Timber Production Zone (TPZ) Assessment. Property taxes for APN 109-170-035 will increase immediately upon approval of the rezoning, and continue to increase annually and incrementally over the ensuing 10 years that the TPZ Assessment restrictions remain in place.

Section IV. If any section, subsection, sentence, clause, or phrase of this Ordinance is for any reason held to be unconstitutional or invalid, such decision shall not affect the validity of the remaining portion of this Ordinance. The Board of Supervisors hereby declares that it would have passed this Ordinance and every section, subsection, sentence, clause or phrase thereof irrespective of the fact that any one or more sections, subsections, sentences, clauses or phrases be declared unconstitutional or invalid.

SECTION V: This Ordinance shall be and the same is hereby declared to be in full force and effect automatically from and after thirty (30) days following California Coastal Commission certification, and shall be carried out in a manner fully consistent with the California Coastal Act. This item involves an amendment to the Local Coastal Program and is not effective until and unless approved by the California Coastal Commission.

SECTION VI: This Ordinance shall be published once before the expiration of fifteen (15) days after said passage, with the names of the Supervisors voting for or against the same, in a newspaper of general circulation, published in the County of Sonoma, State of California.

In regular session of the Board of Supervisors of the County of Sonoma, introduced on the ___ day of ___, 2018, and finally passed and adopted this ___ day of ___, 2018, on regular roll call of the members of said Board by the following vote:

SUPERVISORS:

Gorin: ___ Rabbitt: ___ Zane: ___ Hopkins: ___ Gore: ___

Ayes: _____ Noes: _____ Absent: _____ Abstain: _____

WHEREUPON, the Chair declared the above and foregoing Ordinance duly adopted and

SO ORDERED.

James Gore
Chair, Board of Supervisors
County of Sonoma

ATTEST:

Sheryl Bratton,
Clerk of the Board of Supervisors

Existing Zoning

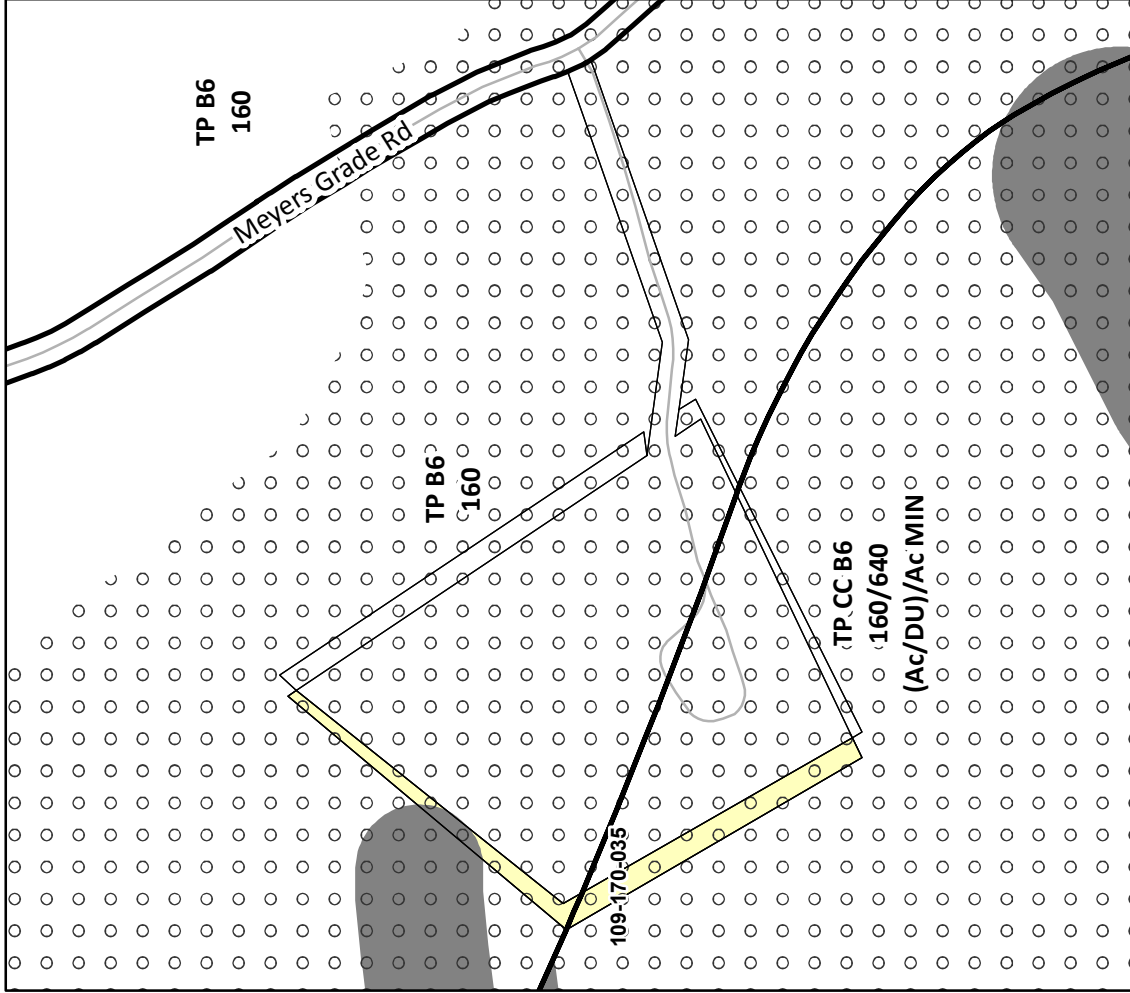

Proposed Zoning

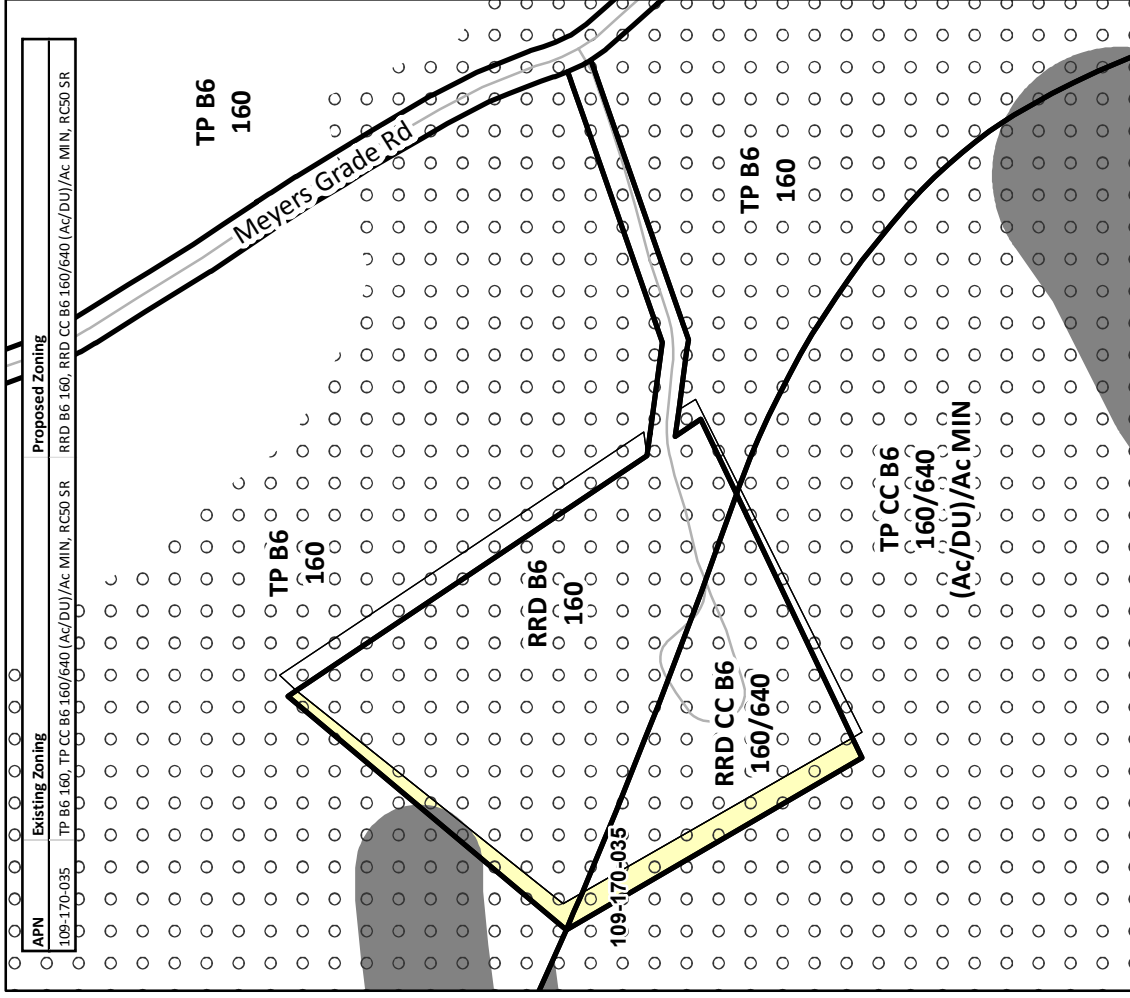

APN	Existing Zoning	Proposed Zoning
109-170-035	TP B6 160, TP CC B6 160/640 (Ac/DU)/Ac MIN, RC50 SR	RRD B6 160, RRD CC B6 160/640 (Ac/DU)/Ac MIN, RC50 SR

Base Map Data

- Subject Parcel
- Parcel
- Base zoning by Area
- Street

Zoning Combining Districts

- RC Riparian Corridor
- SR Scenic Resource

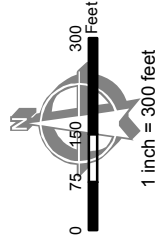

FILE: ZCE18-0011-C
 APN: 109-170-035
 Ordinance No. TBD
 Sectional District Map No. TBD

Permit and Resource Management Department
 Project Review Section
 2550 Ventura Avenue, Santa Rosa, CA 95403
 (707) 565-1965 Fax (707) 565-1103

ORDINANCE NO. ()

AN ORDINANCE OF THE BOARD OF SUPERVISORS OF THE COUNTY OF SONOMA, STATE OF CALIFORNIA, AMENDING THE OFFICIAL ZONING DATABASE AND COASTAL ZONING DATABASE OF THE COUNTY OF SONOMA, ADOPTED BY REFERENCE BY SECTION 26-02-110 OF THE SONOMA COUNTY CODE, BY RECLASSIFYING CERTAIN REAL PROPERTY FROM THE RRD (RESOURCES AND RURAL DEVELOPMENT), B6 160-ACRE DENSITY / RRD (RESOURCES AND RURAL DEVELOPMENT) CC (COASTAL ZONE) B6 160/640-ACRE DENSITY/ACRES MINIMUM, RC 50/50 (RIPARIAN CORRIDOR WITH 50-FOOT SETBACKS), RC 100/50 (RIPARIAN CORRIDOR WITH 100-FOOT AND 50-FOOT SETBACKS), SR (SCENIC RESOURCES) TO TP (TIMBERLAND PRODUCTION), B6 160-ACRE DENSITY / TP (TIMBERLAND PRODUCTION) CC (COASTAL ZONE) B6 160/640-ACRE DENSITY/ACRES MINIMUM, RC 50/50 (RIPARIAN CORRIDOR WITH 50-FOOT SETBACKS), RC 100/50 (RIPARIAN CORRIDOR WITH 100-FOOT AND 50-FOOT SETBACKS), SR (SCENIC RESOURCES) ZONING DISTRICT FOR 0.7 ACRES LOCATED AT 15600 HIGHWAY 1, JENNER; APN 109-170-032, AND -033.

The Board of Supervisors of the County of Sonoma, State of California, ordains as follows:

Section I. The Official Zoning Database (OZD) and Coastal Zoning Database (CZD) of the County, adopted by reference by Section 26-02-110 of the Sonoma County Code, is amended by reclassifying the following real property from the RRD (Resources and Rural Development), B6 160-acre density / RRD (Resources and Rural Development) CC (Coastal Zone) B6 160/640-acre density/acres minimum, RC 50/50 (Riparian Corridor with 50-foot setbacks), RC 100/50 (Riparian Corridor with 100-foot and 50-foot setbacks), SR (Scenic Resources) to the TP (Timberland Production) B6 160-acre density / TP (Timberland Production) CC (Coastal Zone) B6 160/640-acre density/acres minimum, RC 50/50 (Riparian Corridor 50-foot setbacks), RC 100/50 (Riparian Corridor with 100-foot and 50-foot setbacks), SR (Scenic Resources) district, for 0.7 acres located at located at 15600 Highway 1, Jenner; APN 109-170-032, and -033. File No. ZCE18-0011. The Director of the Permit and Resource Management Department is directed to reflect this amendment in the OZD and the CZD of the County as shown on the attached Exhibit A.

Section II. The Proposed Project is exempt from the California Environmental Quality Act (CEQA) pursuant to Section 15061(b)(3) of the State CEQA guidelines as it can be seen with certainty that the project will have no significant effect on the environment since the project consists of technical corrections and minor changes that remove split zoning resulting from a prior project approval.

Section III. The Board of Supervisors authorizes the County Assessor to assign Timber Production Zone (TPZ) Assessment to Robert Mann's land located at 15600 Highway 1, Jenner; APN 109-170-032, and -033.

Section IV. If any section, subsection, sentence, clause, or phrase of this Ordinance is for any reason held to be unconstitutional or invalid, such decision shall not affect the validity of the remaining portion of this Ordinance. The Board of Supervisors hereby declares that it would have passed this Ordinance and every section, subsection, sentence, clause or phrase thereof irrespective of the fact that any one or more sections, subsections, sentences, clauses or phrases be declared unconstitutional or invalid.

SECTION V: This Ordinance shall be and the same is hereby declared to be in full force and effect automatically from and after thirty (30) days following California Coastal Commission certification, and shall be carried out in a manner fully consistent with the California Coastal Act. This item involves an amendment to the Local Coastal Program and is not effective until and unless approved by the California Coastal Commission.

SECTION VI: This Ordinance shall be published once before the expiration of fifteen (15) days after said passage, with the names of the Supervisors voting for or against the same, in a newspaper of general circulation, published in the County of Sonoma, State of California.

In regular session of the Board of Supervisors of the County of Sonoma, introduced on the ___ day of ___, 2018, and finally passed and adopted this ___ day of ___, 2018, on regular roll call of the members of said Board by the following vote:

SUPERVISORS:

Gorin: ___ Rabbitt: ___ Zane: ___ Hopkins: ___ Gore: ___

Ayes: _____ Noes: _____ Absent: _____ Abstain: _____

WHEREUPON, the Chair declared the above and foregoing Ordinance duly adopted and

SO ORDERED.

James Gore
Chair, Board of Supervisors
County of Sonoma

ATTEST:

Sheryl Bratton,
Clerk of the Board of Supervisors

Existing Zoning

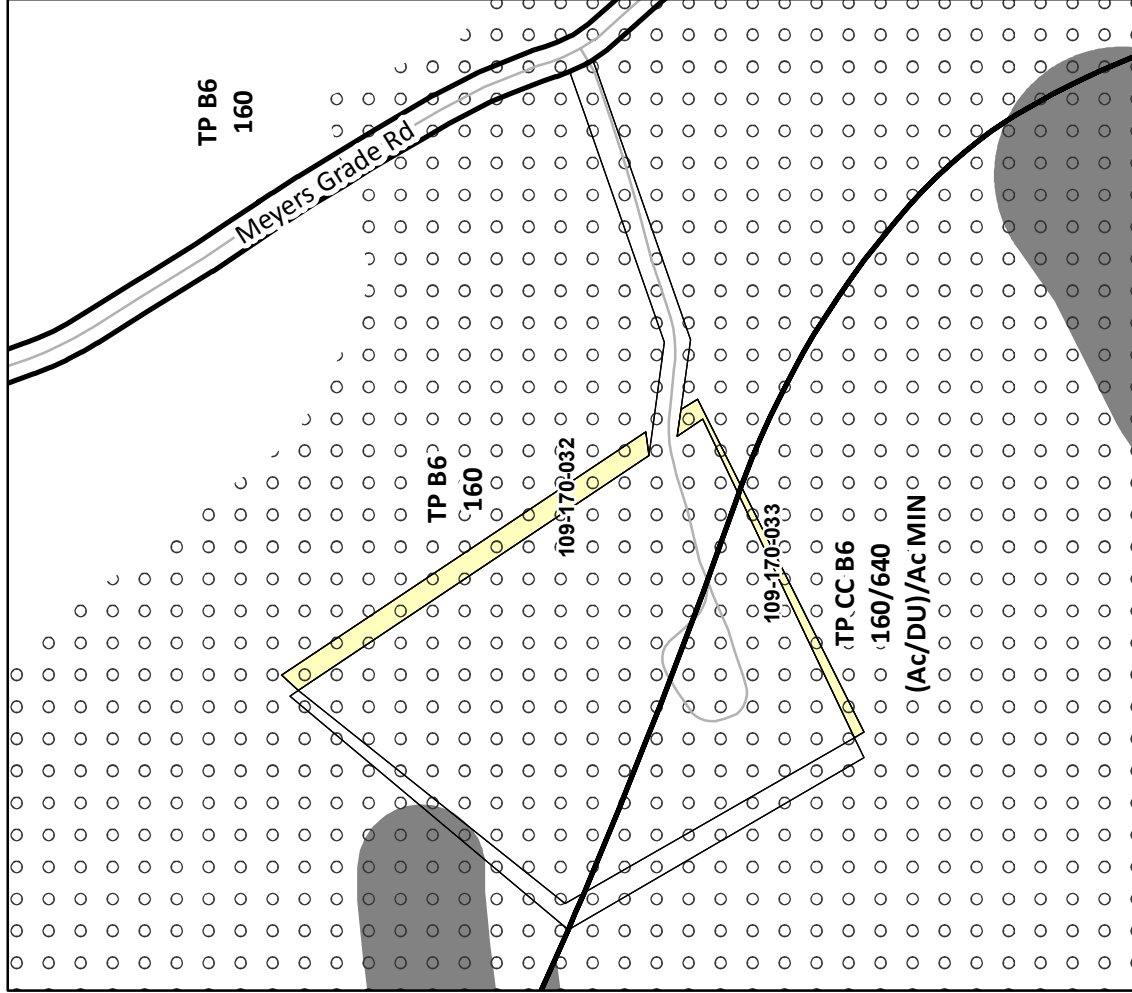

Proposed Zoning

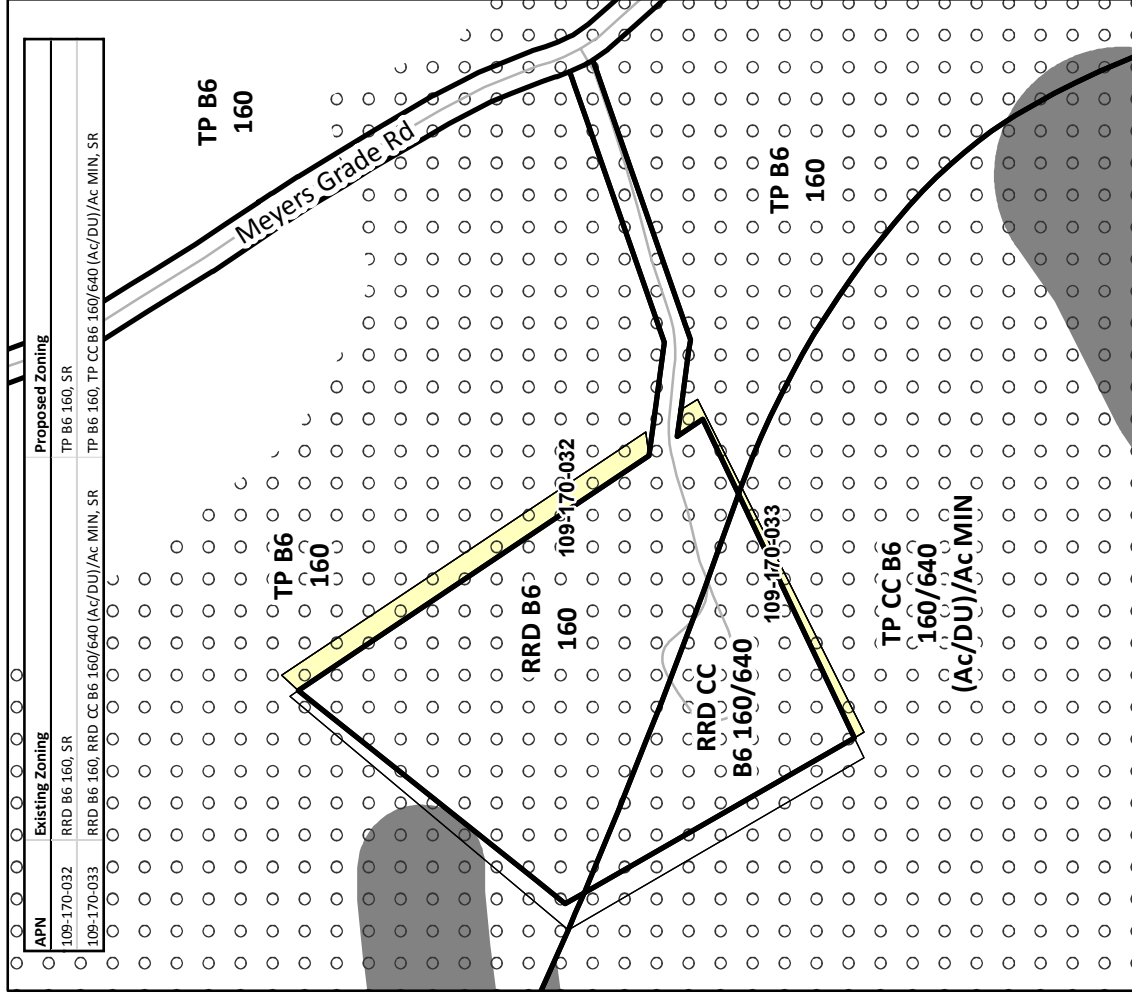

APN	Existing Zoning	Proposed Zoning
109-170-032	RRD B6 160, SR	TP B6 160, SR
109-170-033	RRD B6 160, RRD CC B6 160/640 (Ac/DU)/Ac MIN, SR	TP B6 160, TP CC B6 160/640 (Ac/DU)/Ac MIN, SR

Base Map Data

- Subject Parcel
- Parcel
- Base zoning by Area
- Street

Zoning Combining Districts

- RC Riparian Corridor
- SR Scenic Resource

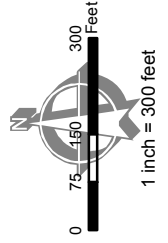

FILE: ZCE18-0011-B
 APNs: 109-170-032, & -033
 Ordinance No. TBD
 Sectional District Map No. TBD

Permit and Resource Management Department
 Project Review Section
 2550 Ventura Avenue, Santa Rosa, CA 95403
 (707) 565-1965 Fax (707) 565-1103

VICINITY MAP



GENERAL PLAN LAND USE MAP

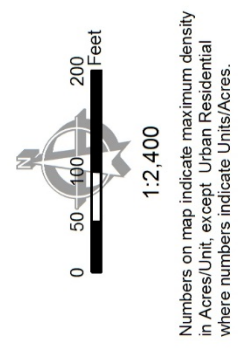
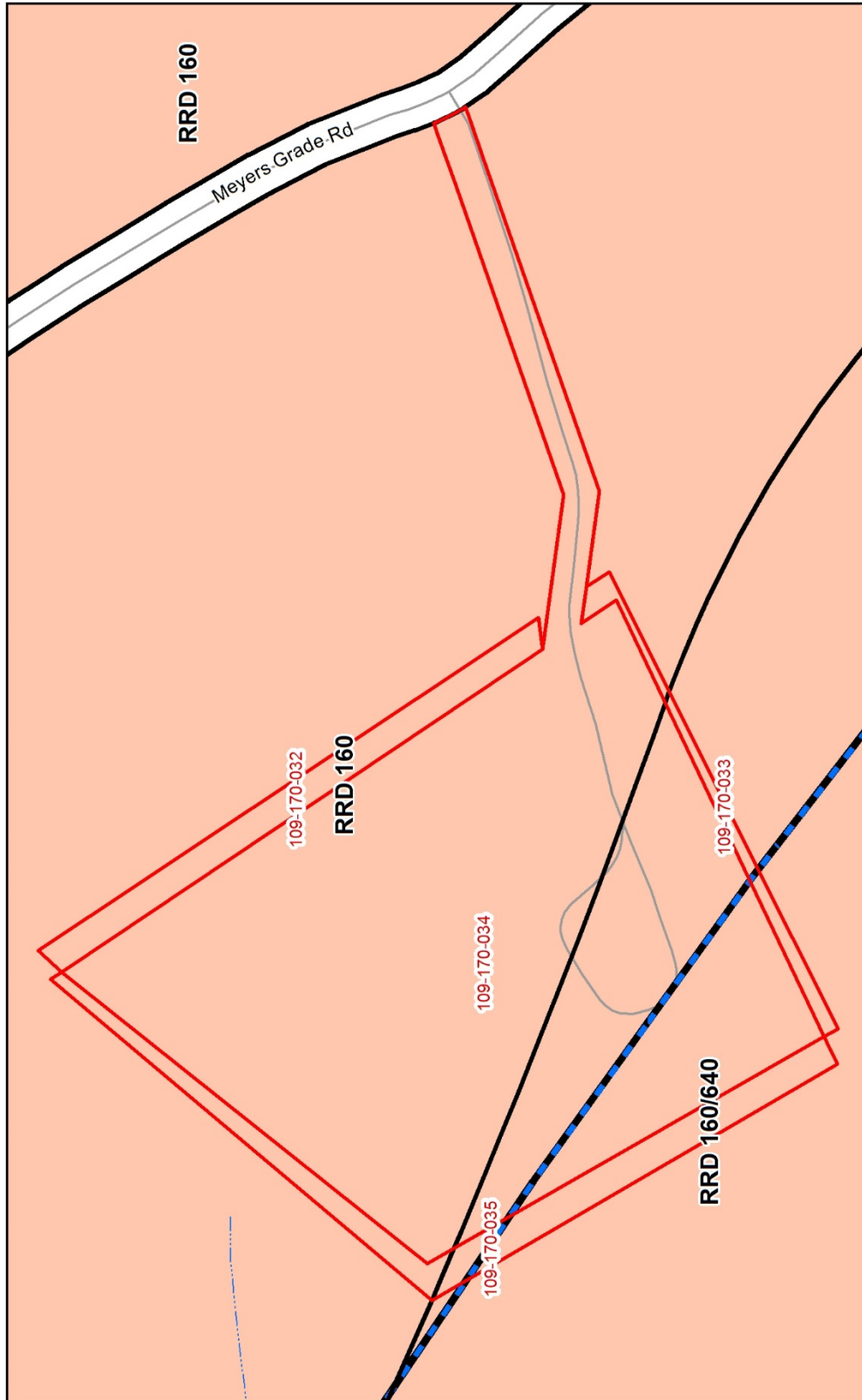

Base Map Data

- Subject Parcel
- Coastal Commission Boundary
- Street
- Intermittent Stream

General Plan Land Use

- Land Use by Area
- Resources & Rural Development

COUNTY ASSESSOR'S PARCEL MAP

MUNIZ RANCHO
T8N R12W

TAX RATE AREA
83-001

109-17

SCALE: 1"=1000'

REVISED
01-06-82
05-19-82
09-24-01=31-LSL
04-03-17=36-KB

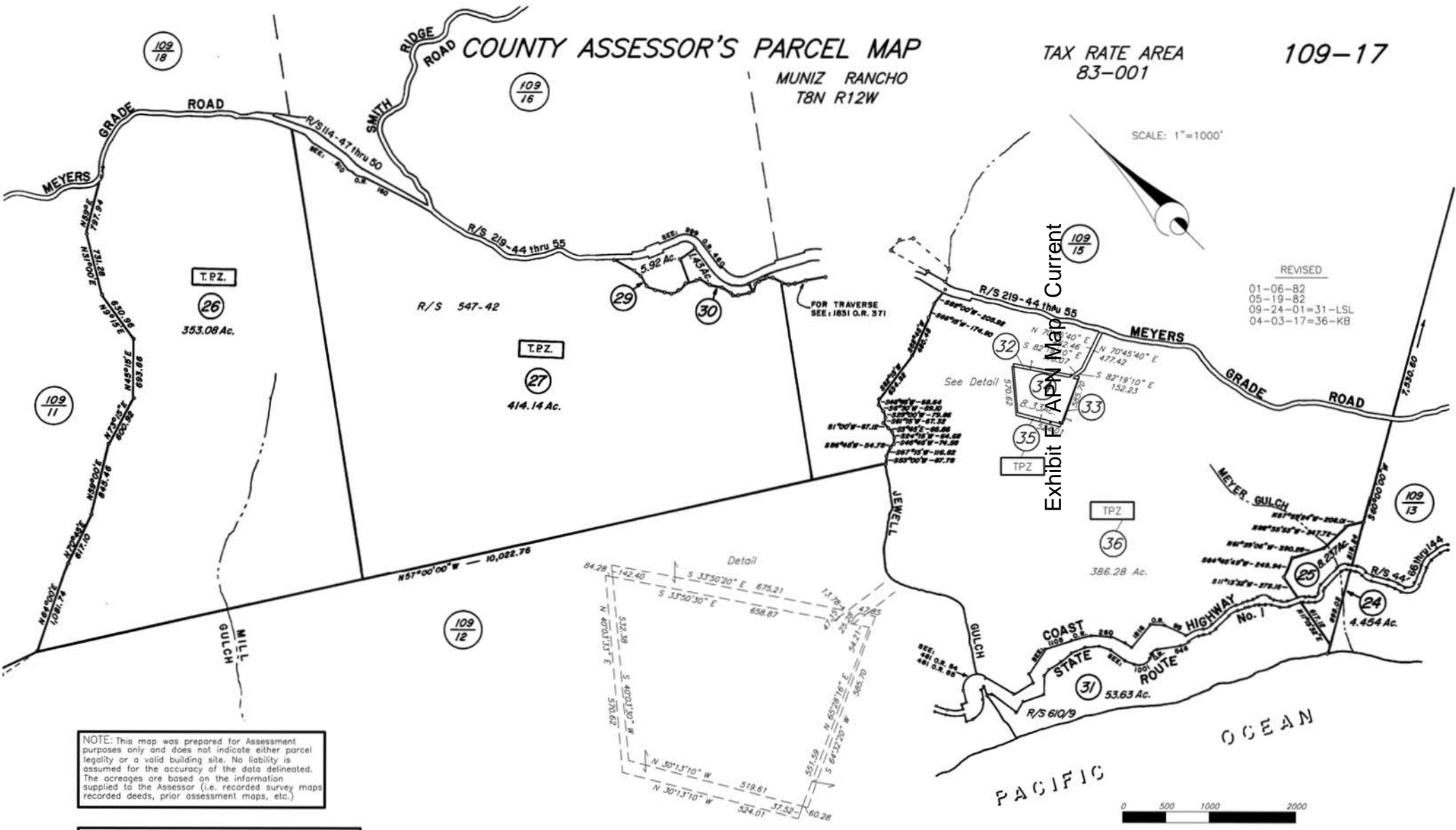

NOTE: This map was prepared for Assessment purposes only and does not indicate either parcel legality or a valid building site. No liability is assumed for the accuracy of the data delineated. The acreages are based on the information supplied to the Assessor (i.e. recorded survey maps, recorded deeds, prior assessment maps, etc.)

NOTE: Assessor's parcels do not necessarily constitute legal lots. To verify legal parcel status, check with the appropriate city or county community development or planning division.

Assessor's Map Bk. 109, Pg. 17
Sonoma County, Calif. (ACAD)

HYBRID 03-30-17 KB

MUNIZ RANCHO

T. 8 N. R. 12 W.

TAX RATE AREA
83-001

109-17

Revised
1-13-78
1-6-82
5-19-82
LSL 9-24-01-31

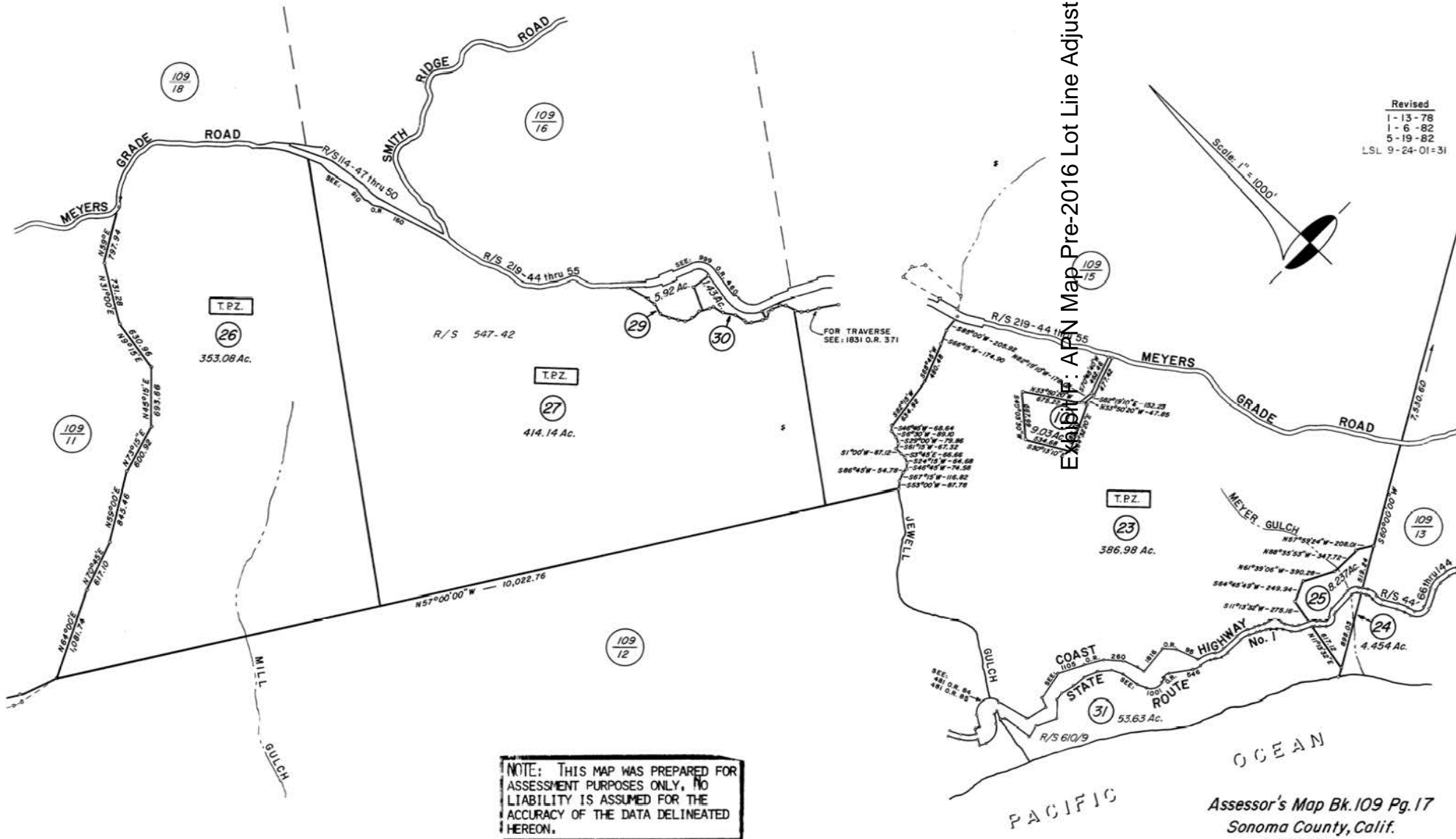

EX-101: APN Map Pre-2016 Lot Line Adjustment

NOTE: THIS MAP WAS PREPARED FOR ASSESSMENT PURPOSES ONLY. NO LIABILITY IS ASSUMED FOR THE ACCURACY OF THE DATA DELINEATED HEREON.

Assessor's Map Bk. 109 Pg. 17
Sonoma County, Calif.
dwn. 5-19-82

Cal Gov Code § 51104

Currency Statement Missing

Deering's California Codes Annotated > GOVERNMENT CODE > Title 5 Local Agencies > Division 1 Cities and Counties > Part 1 Powers and Duties Common to Cities and Counties > Chapter 6.7 Timberland > Article 1 General Provisions

§ 51104. Definitions

As used in this chapter, unless otherwise apparent from the context:

- (a) "Board" means the board of supervisors of a county or city and county, whether general law or chartered, which establishes or proposes to establish a timberland production zone pursuant to this chapter.
- (b) "Contiguous" means two or more parcels of land that are adjoining or neighboring or are sufficiently near to each other, as determined by the board or council, that they are manageable as a single forest unit.
- (c) "Council" means the city council of a city, whether general law or chartered, which establishes or proposes to establish a timberland production zone pursuant to this chapter.
- (d) "County" or "city" means the county or city having jurisdiction over the land.
- (e) "Timber" means trees of any species maintained for eventual harvest for forest products purposes, whether planted or of natural growth, standing or down, on privately or publicly owned land, including Christmas trees, but does not mean nursery stock.
- (f) "Timberland" means privately owned land, or land acquired for state forest purposes, which is devoted to and used for growing and harvesting timber, or for growing and harvesting timber and compatible uses, and which is capable of growing an average annual volume of wood fiber of at least 15 cubic feet per acre.
- (g) "Timberland production zone" or "TPZ" means an area which has been zoned pursuant to Section 51112 or 51113 and is devoted to and used for growing and harvesting timber, or for growing and harvesting timber and compatible uses, as defined in subdivision (h).

With respect to the general plans of cities and counties, "timberland preserve zone" means "timberland production zone."

(h) "Compatible use" is any use which does not significantly detract from the use of the property for, or inhibit, growing and harvesting timber, and shall include, but not be limited to, any of the following, unless in a specific instance such a use would be contrary to the preceding definition of compatible use:

- (1) Management for watershed.
- (2) Management for fish and wildlife habitat or hunting and fishing.
- (3) A use integrally related to the growing, harvesting and processing of forest products, including but not limited to roads, log landings, and log storage areas.
- (4) The erection, construction, alteration, or maintenance of gas, electric, water, or communication transmission facilities.
- (5) Grazing.

Cal Gov Code § 51104

(6)A residence or other structure necessary for the management of land zoned as timberland production.

(i)"Parcel" means that portion of an assessor's parcel that is timberland, as defined.

(j)"Anniversary date" means the anniversary of the date on which zoning is established pursuant to Section 51112 or 51113 takes effect.

(k)"Tax rate area" means a geographical area in which there is a unique combination of tax levies.

(l)"Nonconforming use" means any use within a TPZ which lawfully existed on the effective date of zoning established pursuant to Sections 51112 and 51113, and continuing since that time, which is not a compatible use.

History

Added Stats 1976 ch 176 § 4.5, effective May 24, 1976, as Gov C § 51100. Amended Stats 1977 ch 853 § 4, effective September 17, 1977; Stats 1979 ch 373 § 161; Amended and renumbered Stats 1982 ch 1489 § 1.

Deering's California Codes Annotated
Copyright © 2018 Matthew Bender & Company, Inc.
a member of the LexisNexis Group. All rights reserved.

End of Document

Cal Gov Code § 51113.5

Currency Statement Missing

Deering's California Codes Annotated > GOVERNMENT CODE > Title 5 Local Agencies > Division 1 Cities and Counties > Part 1 Powers and Duties Common to Cities and Counties > Chapter 6.7 Timberland > Article 2 Timberland Production Zones

§ 51113.5. Petition by owner to add to timberland production zone; Land exchanges

(a)After March 1, 1977, an owner with timberlands in a timberland production zone pursuant to Section 51112 or 51113 may petition the board or council to add to his or her timberland production lands that meet the criteria of subdivisions (f) and (g) of Section 51104 and that are contiguous to the timberland already zoned as timberland production. Section 51113 shall not apply to these lands.

(b)In the event of land exchanges with, or acquisitions from, a public agency in which the size of an owner's parcel or parcels zoned as timberland production pursuant to Section 51112 or 51113 is reduced, the timberland production shall not be removed from the parcel except pursuant to Section 51121 and except for a cause other than the smaller parcel size.

History

Added Stats 1976 ch 176 § 4.5, effective May 24, 1976. Amended Stats 1977 ch 853 § 7, effective September 17, 1977; Stats 1982 ch 1489 § 7.

Deering's California Codes Annotated
Copyright © 2018 Matthew Bender & Company, Inc.
a member of the LexisNexis Group. All rights reserved.

End of Document

Cal Gov Code § 51113

Currency Statement Missing

Deering's California Codes Annotated > GOVERNMENT CODE > Title 5 Local Agencies > Division 1 Cities and Counties > Part 1 Powers and Duties Common to Cities and Counties > Chapter 6.7 Timberland > Article 2 Timberland Production Zones

§ 51113. Zoning of land as timberland production upon petition of owner

(a)

(1) An owner may petition the board or council to zone his or her land as timberland production. The board or council by ordinance, after the advice of the planning commission pursuant to Section 51110.2, and after public hearing, shall zone as timberland production all parcels submitted to it by petition pursuant to this section, which meet all of the criteria adopted pursuant to subdivision (c). Any owner who has so petitioned and whose land is not zoned as timberland production may petition the board or council for a rehearing on the zoning.

(2) This section shall not be construed as limiting the ability of the board or council to zone as timberland production any parcel submitted upon petition that is timberland, defined pursuant to subdivision (f) of Section 51104, and which is in compliance with the compatible use ordinance adopted by the board or council pursuant to Section 51111.

(b) The board or council, on or before March 1, 1977, by resolution, shall adopt procedures for initiating, filing, and processing petitions for timberland production zoning and for rezoning. The rules shall be applied uniformly throughout the county or city.

(c) On or before March 1, 1977, the board or council by ordinance shall adopt a list of criteria required to be met by parcels being considered for zoning as timberland production under this section. The criteria shall not impose any requirements in addition to those listed in this subdivision and in subdivision (d). The following shall be included in the criteria:

(1) A map shall be prepared showing the legal description or the assessor's parcel number of the property desired to be zoned.

(2) A plan for forest management shall be prepared or approved as to content, for the property by a registered professional forester. The plan shall provide for the eventual harvest of timber within a reasonable period of time, as determined by the preparer of the plan.

(3)

(A) The parcel shall currently meet the timber stocking standards as set forth in [Section 4561 of the Public Resources Code](#) and the forest practice rules adopted by the State Board of Forestry and Fire Protection for the district in which the parcel is located, or the owner shall sign an agreement with the board or council to meet those stocking standards and forest practice rules by the fifth anniversary of the signing of the agreement. If the parcel is subsequently zoned as timberland production under subdivision (a), failure to meet the stocking standards and forest practice rules within this time period provides the board or council with a ground for rezoning of the parcel pursuant to Section 51121.

(B) Upon the fifth anniversary of the signing of an agreement, the board shall determine whether the parcel meets the timber stocking standards in effect on the date that the agreement was signed. Notwithstanding the provisions of Article 4 (commencing with Section 51130), if the parcel fails to

Cal Gov Code § 51113

meet the timber stocking standards, the board or council shall immediately rezone the parcel and specify a new zone for the parcel, which is in conformance with the county general plan and whose primary use is other than timberland.

(4) The parcel shall be timberland, as defined in subdivision (f) of Section 51104.

(5) The parcel shall be in compliance with the compatible use ordinance adopted by the board or council pursuant to Section 51111.

(d) The criteria required by subdivision (c) may also include any or all of the following:

(1) The land area concerned shall be in the ownership of one person, as defined in [Section 38106 of the Revenue and Taxation Code](#), and shall be comprised of single or contiguous parcels of a certain number of acres, not to exceed 80 acres.

(2) The land shall be a certain site quality class or higher under [Section 434 of the Revenue and Taxation Code](#), except that the parcel shall not be required to be of the two highest site quality classes.

History

Added Stats 1976 ch 176 § 4.5, effective May 24, 1976. Amended Stats 1977 ch 853 § 6, effective September 17, 1977; Stats 1982 ch 1489 § 6; [Stats 1998 ch 972 § 5 \(SB 989\)](#).

Deering's California Codes Annotated
Copyright © 2018 Matthew Bender & Company, Inc.
a member of the LexisNexis Group. All rights reserved.

End of Document

Cal Gov Code § 51120

Currency Statement Missing

Deering's California Codes Annotated > GOVERNMENT CODE > Title 5 Local Agencies > Division 1 Cities and Counties > Part 1 Powers and Duties Common to Cities and Counties > Chapter 6.7 Timberland > Article 3 Rezoning

§ 51120. Procedure upon filing of owner's written notice of desire to rezone; Rehearing upon denial of request

- (a) If the owner desires in any year to rezone a parcel from its current timberland production zone, the owner shall give written notice, naming the new zone desired, and shall follow procedures established pursuant to Sections 65854 to 65857, inclusive. Unless the written notice is given at least 90 days prior to the anniversary date of initial zoning, the zoning term shall be deemed extended.
- (b) Within 120 days of receipt of the written notice of an owner's desire to rezone a parcel, the board or council, after a public hearing, shall rule on the request for rezoning.
- (c) The board or council by a majority vote of the full body may remove the parcel from the timberland production zone and shall specify a new zone for the parcel.
- (d) The new zone approved pursuant to subdivision (c) shall become effective 10 years from the date of approval. Upon rezoning the parcel shall be valued pursuant to [Section 426 of the Revenue and Taxation Code](#), in the same manner as if a restriction were terminated as provided for in Section 51091 or 51245.
- (e) If the board or council denies the owner's request for change of zone pursuant to subdivision (b), the owner may petition for a rehearing.

History

Added Stats 1976 ch 176 § 4.5, effective May 24, 1976. Amended Stats 1982 ch 1489 § 17.

Deering's California Codes Annotated
Copyright © 2018 Matthew Bender & Company, Inc.
a member of the LexisNexis Group. All rights reserved.

End of Document

Cal Gov Code § 51121

Currency Statement Missing

Deering's California Codes Annotated > GOVERNMENT CODE > Title 5 Local Agencies > Division 1 Cities and Counties > Part 1 Powers and Duties Common to Cities and Counties > Chapter 6.7 Timberland > Article 3 Rezoning

§ 51121. Procedure upon written notice of board or council of intent to rezone; Protest by owner; Effective term of new zone

- (a) If the board or council after public hearing and by a majority vote of the full body desires in any year not to extend the term of zoning, the county or city shall give written notice of its intent to rezone following procedures established pursuant to subdivision (b) of Section 51113. A proposed new zone shall be specified. Unless the written notice is given at least 90 days prior to the anniversary date of the initial zoning, the zoning term shall be deemed extended.
- (b) Upon receipt by the owner of a notice of intent to rezone from the county or city, the owner may make written protest of the notice and may appeal to the board or council within 30 days of notice from the county or city. The board or council may at any time prior to the anniversary date withdraw the notice of intent to rezone.
- (c) The board or council shall hold a public hearing on the proposed change and by a majority vote of the full body may reaffirm its intent to change the zoning and specify a new zone.
- (d) A new zone of a parcel shall be effective 10 years from the date of the reaffirmation vote pursuant to subdivision (c). Upon rezoning the parcel shall be valued pursuant to [Section 426 of the Revenue and Taxation Code](#).
- (e) The owner may petition to be reheard.

History

Added Stats 1976 ch 176 § 4.5, effective May 24, 1976. Amended Stats 1977 ch 853 § 10, effective September 17, 1977.

Deering's California Codes Annotated
Copyright © 2018 Matthew Bender & Company, Inc.
a member of the LexisNexis Group. All rights reserved.

End of Document

[Cal Gov Code § 51140](#)

Currency Statement Missing

Deering's California Codes Annotated > GOVERNMENT CODE > Title 5 Local Agencies > Division 1 Cities and Counties > Part 1 Powers and Duties Common to Cities and Counties > Chapter 6.7 Timberland > Article 5 Removal From Zone

§ 51140. Certification and effective date of rezoning

Upon rezoning, the board or council shall certify the rezoning indicating the new zone and its effective date.

History

Added Stats 1976 ch 176 § 4.5, effective May 24, 1976.

Deering's California Codes Annotated
Copyright © 2018 Matthew Bender & Company, Inc.
a member of the LexisNexis Group. All rights reserved.

End of Document

[Cal Gov Code § 51141](#)

Currency Statement Missing

Deering's California Codes Annotated > GOVERNMENT CODE > Title 5 Local Agencies > Division 1 Cities and Counties > Part 1 Powers and Duties Common to Cities and Counties > Chapter 6.7 Timberland > Article 5 Removal From Zone

§ 51141. Certification together with map recorded by city or county; Assessment for tax purposes

A copy of the certification of rezoning together with the map and assessor's parcel numbers for the rezoned land shall be recorded by the city or county in the recorder's office in the same manner as deeds are recorded, and commencing on the lien date next following the effective date of the new zone, such land shall be assessed on the same basis as real property is assessed generally in that county. The assessor may require a description of the portion of the property rezoned as provided in [Section 456 of the Revenue and Taxation Code](#).

History

Added Stats 1976 ch 176 § 4.5, effective May 24, 1976.

Deering's California Codes Annotated
Copyright © 2018 Matthew Bender & Company, Inc.
a member of the LexisNexis Group. All rights reserved.

End of Document

Resolution Number 18-018

County of Sonoma
Santa Rosa, California

October 4, 2018
ZCE18-0011 Hannah Spencer

RESOLUTION OF THE PLANNING COMMISSION, COUNTY OF SONOMA, STATE OF CALIFORNIA, FINDING THE PROJECT EXEMPT FROM CEQA AND RECOMMENDING APPROVAL OF THE ZONE CHANGE TO THE BOARD OF SUPERVISORS AS REQUESTED BY TOM BERRY AND THE COUNTY OF SONOMA, FOR PROPERTY LOCATED AT 15600 HIGHWAY 1 AND 14500 MEYERS GRADE ROAD, JENNER; APN 109-170-032, -033, AND -034.

WHEREAS, the applicant, Tom Berry, filed an application with the Sonoma County Permit and Resource Management Department to rezone 9.03 acres of land from the TP (Timberland Production), B6 160-acre density / TP (Timberland Production) CC (Coastal Zone) B6 160/640-acre density/acres minimum, RC 50/50 (Riparian Corridor with 50-foot setbacks), RC 100/50 (Riparian Corridor with 100-foot and 50-foot setbacks), SR (Scenic Resources) to the RRD (Resources and Rural Development) B6 160-acre density / RRD (Resources and Rural Development) CC (Coastal Zone) B6 160/640-acre density/acres minimum, RC 50/50 (Riparian Corridor 50-foot setbacks), RC 100/50 (Riparian Corridor with 100-foot and 50-foot setbacks), SR (Scenic Resources) district, or other appropriate district on property located at 15600 Highway 1 and 14500 Meyers Grade Road, Jenner; APN 109-170-032, -033, and -034; Supervisorial District No. 5; and,

WHEREAS, this project has been found to be categorically exempt from CEQA pursuant to CEQA Guidelines, Section 15061(b)(3) as it can be seen with certainty that the project will have no significant effect on the environment since the project consists of technical corrections and minor changes that resolve zoning errors; and,

WHEREAS, in accordance with the provisions of law, the Planning Commission held a public hearing on October 4, 2018, at which time all interested persons were given an opportunity to be heard; and,

WHEREAS, Permit Sonoma periodically identifies zoning and/or land use discrepancies to improve and maintain the accuracy of the Official Zoning Database and Coastal Zoning Database. Any discrepancies and minor zoning amendments are then brought forward as technical corrections to improve the zoning databases; and,

WHEREAS, while processing PRMD File No. ZCE18-0011, Permit Sonoma staff discovered zoning discrepancies that affect Robert Mann's parcel located at 15600 Highway 1 (APN 109-170-032, -033) and Rachel Curran's and Brian Wares' ("the Currans") parcel located at 14500 Meyers Grade Rd (APN 109-170-034); and,

WHEREAS, historic zoning maps and PRMD records show the County inadvertently rezoned the Currans' land in 1991, from the A1 (Primary Agriculture) / AP (Primary Agriculture) base zoning district to the A1 (Primary Agriculture) / TP (Timberland Production) base zoning district;

and again in 1993, by rezoning the Currans' land from the A1 (Primary Agriculture) / TP (Timberland Production) base zoning district to the TP (Timberland Production) base zoning district; and,

WHEREAS, the Board of Supervisors adopted Ordinance No. 4643 rezoning agricultural and resource lands to match the new General Plan designations and lands in the remote coastal mountain ranges that were previously designated as A1 (Primary Agriculture) and AP (Primary Agriculture) and had no agriculture and/or were not capable of supporting an economically viable agricultural enterprise (due to constraints such as parcel size, soils, and water availability), were rezoned to the RRD (Resources and Rural Development) base zoning district; and,

WHEREAS, consistent with Ordinance No. 4643, the Currans' land located at 14500 Meyers Grade Rd (formerly identified as APN 109-170-010) should have been rezoned from the A1 (Primary Agriculture) base zoning district to the RRD (Resources and Rural Development) base zoning district during the 1993 zoning map update; and,

WHEREAS, in 2016, 0.7 acres of land was exchanged between the Currans' and Robert Mann in Lot Line Adjustment File No. LLA16-0023 and as a result, 0.7 acres of inaccurately zoned land (currently identified as APN 109-170-032 and -033) was transferred to Robert Mann; and,

WHEREAS, the proposed zone change will correct technical zoning errors that resulted from the inadvertent rezoning that occurred in 1991 and 1993, affecting land identified as APN 109-170-032, -033, and -034; and,

WHEREAS, the Planning Commission recommends that the Board of Supervisors find the project exempt from CEQA.

NOW, THEREFORE, BE IT RESOLVED that the Planning Commission makes the following findings:

1. The proposed amendments are necessary to correct errors in the Official Zoning Database and Coastal Zoning Database that resulted from inadvertent rezoning in 1991 and 1993 and to ensure the accuracy and reliability of the planning information on which the public relies.
2. The proposed amendments are consistent and compatible with the Sonoma County General Plan and Local Coastal Plan in that the changes include technical corrections to zoning that ensure the integrity and reliability of the information on which both the public and staff rely. Further, the zoning corrections do not result in changes to the Resources and Rural Development Land Use Designation of the General Plan nor to the Resources and Rural Development Land Use Designation of the Local Coastal Plan.
3. The proposed Amendments are exempt from the California Environmental Quality Act ("CEQA") under Section 15061(b)(3), as it can be seen with certainty that the project will have no significant effect on the environment since the project consists of technical corrections and minor changes that resolve inadvertent zoning errors.

BE IT FURTHER RESOLVED, that the Planning Commission recommends that the Board of Supervisors approve the requested Zone Change; and,

BE IT FURTHER RESOLVED, that the Planning Commission recommends that the Board of Supervisors authorizes staff to submit amendments to the Coastal Zoning

Database forthwith to the California Coastal Commission for certification.

BE IT FURTHER RESOLVED that the Planning Commission designates the Secretary of the Planning Commission as the custodian of the documents and other material which constitute the record of proceedings upon which the decision herein is based. These documents may be found at the office of the Sonoma County Permit and Resource Management Department, 2550 Ventura Avenue, Santa Rosa, CA 95403.

THE FOREGOING RESOLUTION was introduced by Commissioner Davis, who moved its adoption, seconded by Commissioner Carr, and adopted on roll call by the following vote:

Commissioner Carr	Aye
Commissioner Reed	Aye
Commissioner Shahhosseini	Aye
Commissioner Kelley	Aye
Commissioner Davis	Aye

Ayes: 5 Noes: 0 Absent: 0 Abstain: 0

WHEREUPON, the Chair declared the above and foregoing Resolution duly adopted; and

SO ORDERED.

Resolution Number 18-019

County of Sonoma
Santa Rosa, California

October 4, 2018
ZCE18-0011 Hannah Spencer

RESOLUTION OF THE PLANNING COMMISSION, COUNTY OF SONOMA, STATE OF CALIFORNIA, FINDING THE PROJECT EXEMPT FROM CEQA AND RECOMMENDING APPROVAL OF THE ZONE CHANGE TO THE BOARD OF SUPERVISORS AS REQUESTED BY TOM BERRY, FOR PROPERTY LOCATED AT 15600 HIGHWAY 1, JENNER; APN 109-170-032, AND -033.

WHEREAS, the applicant, Tom Berry, filed an application with the Sonoma County Permit and Resource Management Department to rezone 0.7 acres of land from the RRD (Resources and Rural Development) B6 160-acre density / RRD (Resources and Rural Development) CC (Coastal Zone) B6 160/640-acre density/acres minimum, RC 50/50 (Riparian Corridor 50-foot setbacks), RC 100/50 (Riparian Corridor with 100-foot and 50-foot setbacks), SR (Scenic Resources) district to the TP (Timberland Production), B6 160-acre density / TP (Timberland Production) CC (Coastal Zone) B6 160/640-acre density/acres minimum, RC 50/50 (Riparian Corridor with 50-foot setbacks), RC 100/50 (Riparian Corridor with 100-foot and 50-foot setbacks), SR (Scenic Resources) district on property located at 15600 Highway 1, Jenner; APN 109-170-032 and -033; Supervisorial District No. 5;

WHEREAS, this project has been found to be categorically exempt from CEQA pursuant to CEQA Guidelines, Section 15061(b)(3) as it can be seen with certainty that the project will have no significant effect on the environment since the project consists of a technical correction and a minor change that removes split zoning resulting from a prior project approval; and,

WHEREAS, in accordance with the provisions of law, the Planning Commission held a public hearing on October 4, 2018, at which time all interested persons were given an opportunity to be heard; and

WHEREAS, Permit Sonoma periodically identifies zoning and/or land use discrepancies to improve and maintain the accuracy of the Official Zoning Database and Coastal Zoning Database. Any discrepancies and minor zoning amendments are then brought forward as technical corrections to improve the zoning databases; and,

WHEREAS, while processing PRMD File No. ZCE18-0011, Permit Sonoma staff discovered inadvertent split zoning that resulted from approval of LLA16-0023, affecting Robert Mann's parcel located at 15600 Highway 1 (APN 109-170-032, -033); and,

WHEREAS, the 0.7 acres of land located at 15600 Highway 1, Jenner (APN 109-170-032, -033) contains the soils and climate capable of producing timber and is contiguous to timberland already zoned as timberland production; and,

WHEREAS, the proposed zone change will remove the split zoning resulting from approval and recordation of LLA16-0023; and,

WHEREAS, consistent with Government Code Section 51113.5, the Board of Supervisors must authorize the County Assessor to assign Timber Preserve Zone (TPZ) Assessment to Robert Mann's land located at 15600 Highway 1, Jenner (APN 109-170-032, -033); and

WHEREAS, the Planning Commission recommends that the Board of Supervisors find the project exempt from CEQA.

NOW, THEREFORE, BE IT RESOLVED that the Planning Commission makes the following findings:

1. The proposed amendment is necessary to remove split zoning in the Official Zoning Database and Coastal Zoning Database that resulted from prior approval of LLA16-0023 to ensure the accuracy and reliability of the planning information on which the public relies.
2. The proposed amendment is consistent and compatible with the Sonoma County General Plan and Local Coastal Plan in that the change includes a technical correction to zoning that results in accurately reflecting the applicable base zoning district based on property boundaries and eliminates split zoning. Further, the zoning correction does not result in a change to the Resources and Rural Development Land Use Designation of the General Plan nor to the Resources and Rural Development Land Use Designation of the Local Coastal Plan.
3. Placing Robert Mann's 0.7 acres of land located at 15600 Highway 1, Jenner (APN 109-170-032, -033), into timberland production zoning and TPZ Assessment meets the criteria of Government Code Section 51104(f) and (g) because the land contains the soils and climate capable of producing timber and is contiguous to timberland already zoned as timberland production and therefore is consistent with Government Code Sections 51113.5 and 51141.
4. The proposed Amendment is exempt from the California Environmental Quality Act ("CEQA") under Section 15061(b)(3), as it can be seen with certainty that the project will have no significant effect on the environment since the project consists of a minor change that removes split zoning resulting from a prior project approval.

BE IT FURTHER RESOLVED, that the Planning Commission recommends that the Board of Supervisors approve the requested Zone Change; and

BE IT FURTHER RESOLVED, that the Planning Commission recommends that the Board of Supervisors authorize the County Assessor to assign TPZ Assessment to Robert Mann's land located at 15600 Highway 1, Jenner; APN 109-170-032, and -033; Supervisorial District No. 5.

BE IT FURTHER RESOLVED, that the Planning Commission recommends that the Board of Supervisors authorizes staff to submit amendments to the Coastal Zoning Database forthwith to the California Coastal Commission for certification.

BE IT FURTHER RESOLVED that the Planning Commission designates the Secretary of the Planning Commission as the custodian of the documents and other material which constitute the record of proceedings upon which the decision herein is based. These documents may be found at the office of the Sonoma County Permit and Resource Management Department, 2550 Ventura Avenue, Santa Rosa, CA 95403.

THE FOREGOING RESOLUTION was introduced by Commissioner Davis, who moved its adoption, seconded by Commissioner Carr, and adopted on roll call by the following vote:

Commissioner Carr	Aye
Commissioner Reed	Aye
Commissioner Shahhosseini	Aye
Commissioner Kelley	Aye
Commissioner Davis	Aye

Ayes: 5 Noes: 0 Absent: 0 Abstain: 0

WHEREUPON, the Chair declared the above and foregoing Resolution duly adopted; and

SO ORDERED.

Resolution Number 18-020

County of Sonoma
Santa Rosa, California

October 4, 2018
ZCE18-0011 Hannah Spencer

RESOLUTION OF THE PLANNING COMMISSION, COUNTY OF SONOMA, STATE OF CALIFORNIA, FINDING THE PROJECT EXEMPT FROM CEQA AND RECOMMENDING APPROVAL OF THE ZONE CHANGE TO THE BOARD OF SUPERVISORS AS REQUESTED BY TOM BERRY FOR PROPERTY LOCATED AT 14500 MEYERS GRADE ROAD, JENNER; APN 109-170-035.

WHEREAS, the applicant, Tom Berry, filed an application with the Sonoma County Permit and Resource Management Department to rezone 0.7 acres of land from the TP (Timberland Production), B6 160-acre density / TP (Timberland Production) CC (Coastal Zone) B6 160/640-acre density/acres minimum, RC 50/50 (Riparian Corridor with 50-foot setbacks), RC 100/50 (Riparian Corridor with 100-foot and 50-foot setbacks), SR (Scenic Resources) to the RRD (Resources and Rural Development) B6 160-acre density / RRD (Resources and Rural Development) CC (Coastal Zone) B6 160/640-acre density/acres minimum, RC 50/50 (Riparian Corridor 50-foot setbacks), RC 100/50 (Riparian Corridor with 100-foot and 50-foot setbacks), SR (Scenic Resources) district, or other appropriate district on property located at 14500 Meyers Grade Road, Jenner; APN 109-170-035; Supervisorial District No. 5; and,

WHEREAS, this project has been found to be categorically exempt from CEQA pursuant to CEQA Guidelines, Section 15061(b)(3) as it can be seen with certainty that the project will have no significant effect on the environment since the project consists of a technical correction and minor change that removes split zoning; and,

WHEREAS, in accordance with the provisions of law, the Planning Commission held a public hearing on October 4, 2018, at which time all interested persons were given an opportunity to be heard; and,

WHEREAS, Permit Sonoma periodically identifies zoning and/or land use discrepancies to improve and maintain the accuracy of the Official Zoning Database and Coastal Zoning Database. Any discrepancies and minor zoning amendments are then brought forward as technical corrections to improve the zoning databases; and,

WHEREAS, while processing PRMD File No. ZCE18-0011, Permit Sonoma staff discovered the approval and recordation of Lot Line Adjustment File No. LL16-0023 between the Currans' land located at 14500 Meyers Grade Rd (formerly APN 109-170-010; currently APN 109-170-034, -035) and Robert Mann's land located at 15600 Highway 1 (formerly APN 109-170-023; currently APN 109-170-032, -033, -036) resulted in split zoning in which the Currans received 0.7 acres of land that is zoned TP (Timberland Production) with Timber Preserve Zone (TPZ) Assessment; and

WHEREAS, the majority of the Currans' land (APN 109-170-034) is zoned RRD (Resources and Rural Development); and,

WHEREAS, to remove the split zoning that resulted from LLA16-0023 on the Currans' land consistent with Government Code Section 51120, the Board of Supervisors must authorize the County Assessor to phase the Currans' 0.7 acres of land located at 14500 Meyers Grade Road, Jenner (APN 109-170-035), out of TPZ Assessment; and,

WHEREAS, effective 10 years from the date of approval, the Official Zoning Database and Coastal Zoning Database will identify 0.7 acres of land located at 14500 Meyers Grade Road, Jenner (APN 109-170-035) with a RRD (Resources and Rural Development) base zoning district; and,

WHEREAS, property taxes for land located at 14500 Meyers Grade Road, Jenner (APN 109-170-035), will increase immediately upon approval of the rezoning, and continue to increase annually and incrementally over the ensuing 10 years that the TPZ Assessment restrictions remain in place; and,

WHEREAS, the Planning Commission recommends that the Board of Supervisors find the project exempt from CEQA.

NOW, THEREFORE, BE IT RESOLVED that the Planning Commission makes the following findings:

1. The proposed amendment is necessary to remove split zoning in the Official Zoning Database and Coastal Zoning Database that resulted from prior approval of LLA16-0023 to ensure the accuracy and reliability of the planning information on which the public relies.
2. The proposed amendment is consistent and compatible with the Sonoma County General Plan and Local Coastal Plan in that the change includes a technical correction to zoning that results in accurately reflecting the applicable base zoning district based on property boundaries and eliminates split zoning. Further, the zoning correction does not result in a change to the Resources and Rural Development Land Use Designation of the General Plan nor to the Resources and Rural Development Land Use Designation of the Local Coastal Plan.
3. Authorizing 0.7 acres of the Currans' land located at 14500 Meyers Grade Road, Jenner (APN 109-170-035) to phase out of TPZ Assessment, is consistent with Government Code Sections 51120 and 51140.
4. The proposed Amendment is exempt from the California Environmental Quality Act ("CEQA") under Section 15061(b)(3), as it can be seen with certainty that the project will have no significant effect on the environment since the project consists of a minor change that removes split zoning resulting from a prior project approval.

BE IT FURTHER RESOLVED, that the Planning Commission recommends that the Board of Supervisors approve the requested Zone Change; and,

BE IT FURTHER RESOLVED, that the Planning Commission recommends that the Board of Supervisors approves the County Assessor to phase the Currans' 0.7 acres of land located at 14500 Meyers Grade Road, Jenner (APN 109-170-035), out of TPZ Assessment; and,

BE IT FURTHER RESOLVED, that the Planning Commission recommends that the

Board of Supervisors authorizes staff to submit the amendment to the Coastal Zoning Database forthwith to the California Coastal Commission for certification.

BE IT FURTHER RESOLVED that the Planning Commission designates the Secretary of the Planning Commission as the custodian of the documents and other material which constitute the record of proceedings upon which the decision herein is based. These documents may be found at the office of the Sonoma County Permit and Resource Management Department, 2550 Ventura Avenue, Santa Rosa, CA 95403.

THE FOREGOING RESOLUTION was introduced by Commissioner Davis, who moved its adoption, seconded by Commissioner Carr, and adopted on roll call by the following vote:

Commissioner Carr	Aye
Commissioner Reed	Aye
Commissioner Shahhosseini	Aye
Commissioner Kelley	Aye
Commissioner Davis	Aye

Ayes: 5 Noes: 0 Absent: 0 Abstain: 0

WHEREUPON, the Chair declared the above and foregoing Resolution duly adopted; and

SO ORDERED.



Date:

Sonoma County Planning Commission

DRAFT MINUTES

Permit Sonoma
2550 Ventura Avenue, Santa Rosa, CA 95403
(707) 565-1900 FAX (707) 565-1103

Date: October 4, 2018
Meeting No.: 18-12

ROLL CALL

Greg Carr
Larry Reed
Komron Shahhosseini
Ariel Kelley
Pamela Davis, Chair

STAFF MEMBERS

Jennifer Barrett
Hannah Spencer
Arielle Kohn, Secretary
Leslie A. Thomsen, Deputy County Counsel

1:00 PM Call to order and Pledge of Allegiance

Minutes Approved – August 2, 2018

Minutes Continued - Combined PC/BZA – November 9, 2017

Correspondence

Board of Zoning Adjustments/Board of Supervisors Actions

Commissioner Announcements/Disclosures

Public Appearances

PLANNING COMMISSION UNCONTESTED CALENDAR

PC Item No.: 1
Time: 1:05 pm
File: ZCE18-0011
Applicant: Tom Berry and County of Sonoma
Owners: Rachel Curran, Brian Wares and Robert Mann
Cont. from: N/A
Staff: Hannah Spencer
Env. Doc: Categorically Exempt, CEQA Guidelines Section 15061(b)(3)

Proposal: Amend the Official Zoning Database and Coastal Zoning Database to correct minor technical errors resulting from zoning map updates and prior approval of a noncontroversial lot line adjustment.

Location: 14500 Meyers Grade Rd and 5600 Highway 1 in Jenner
APNS: 109-170-034, -035 and 109-170-032, -033
District: 5

Zoning: TP (Timberland Production), B6 160 / TP (Timberland Production) CC (Coastal Zone) B6 160/640 (Ac/DU)/AcMIN, RC (Riparian Corridor) 50-foot and 100-foot setbacks, SR (Scenic Resources)

Hannah Spencer summarized the staff report, which incorporated herein by reference.

Public Hearing Opened: 1:16

Tom Berry, applicant, stated that when the Lot Line Adjustment was approved in 2016, the current situation would normally have been addressed at that time, but it was not. In the mean time, a title nightmare has been created involving grant deeds which created separate parcels, extra tax bills, and an inaccurate property description to to the parcels being dropped from title. Mr. Berry asked for resolution of the problem.

Public Hearing Closed at 1:20

Commissioner Davis asked staff whether these zoning errors would have affected the Lot Line Adjustment. Staff Spencer stated that a way would have been found to approve it after consultation with CalFire. **Deputy Director Barrett** added that we would have required a rezone as a condition of approval. **Commissioner Carr** stated it should have been corrected earlier, and asked staff if the Assessor was OK with the proposed solution. Staff Spencer stated there were no issues with it, and the main issue has been why the current parcel was missing the TPZ assessment.

Action: **Commissioner Davis** motioned to recommend approval of the technical corrections to the Board of Supervisors. The motion also included recommending approval of the two other resolutions. Seconded by **Commissioner Carr** and passed with a 5-0 vote.

Appeal Deadline: N/A

Resolution No.: 18-018

Resolution No.: 18-019 (Zone change at 15600 Highway 1, Jenner APN 109-170-032 and -033)

Resolution No.: 18-020 (Zone change at 14500 Meyers Grade Road, Jenner APN 109-170-035)

Vote:

Commissioner Carr - aye

Commissioner Reed - aye

Commissioner Shahhosseini - aye

Commissioner Kelley - aye

Commissioner Davis - aye

Ayes: 5

Noes: 0

Absent: 0

Abstain: 0



County of Sonoma Agenda Item Summary Report

Clerk of the Board
575 Administration Drive
Santa Rosa, CA 95403

Agenda Item Number: 49
(This Section for use by Clerk of the Board Only.)

To: Board of Directors of the Sonoma County Agricultural Preservation and Open Space District

Board Agenda Date: November 13, 2018

Vote Requirement: Majority

Department or Agency Name(s): Sonoma County Agricultural Preservation and Open Space District

Staff Name and Phone Number:

Misti Arias, 565- 7264
Jennifer Kuszmar, 565-7266

Supervisorial District(s):

Title: 2018 Matching Grant Program Funding Recommendations

Recommended Actions:

Accept Recommendations for Projects and Funding Amounts for the 2018 Matching Grant Program Cycle.

Executive Summary:

The Sonoma County Agricultural Preservation and Open Space District offers a competitive Matching Grant Program for urban open space, natural resource restoration, and recreation projects every two years. During the 2018 funding cycle, the Sonoma County Agricultural Preservation and Open Space District received nine applications totaling \$7.1 million in funding. Sonoma County Agricultural Preservation and Open Space District is recommending funding five projects for a total of \$2,426,943 and is requesting that the Board of Directors accept these recommendations.

Discussion:

Background

Through the Sonoma County Agricultural Preservation and Open Space District's ("Ag + Open Space") Expenditure Plan, Sonoma County voters have authorized Ag + Open Space to fund urban open space, natural resource restoration, and recreation projects through a competitive Matching Grant Program ("Program"). The Program is available to cities, the County, other public agencies, and 501(c)3 nonprofit organizations.

Since 1994, the Program has provided over \$33 million in funding for projects in each of the county's nine incorporated cities and in numerous unincorporated areas. Program funding has allowed our public and nonprofit partners to leverage funds to develop and implement diverse and innovative projects throughout Sonoma County's communities. Some projects funded through the Program include the Windsor Town Green and Keiser Park in Windsor; Sonoma Garden Park and Nathanson Creek Restoration in Sonoma; Alman Marsh and Paula Lane Open Space Preserve in Petaluma; Prince Gateway

Park and Bayer Neighborhood Park and Gardens in Santa Rosa; Tomodachi and Skategarden Parks in Sebastopol; Giorgi Park in Healdsburg; Falletti Ranch in Cotati; and numerous projects in unincorporated areas such as Forever Forestville in Forestville, and Creekside Park in Monte Rio.

2018 Matching Grant Program Funding Cycle

For the last several Program cycles, Ag + Open Space has budgeted around \$2 million per cycle. Following the October 2017 fires, the Ag + Open Space General Manager opted to double the budget to allocate \$4 million to the 2018 Program cycle to provide additional funding to support eligible projects within burned areas. Higher than anticipated sales-tax revenues were sufficient to support the increase to the budget this funding cycle.

In January 2018, Ag + Open Space opened the 2018 funding cycle with two informational public meetings. When the application period closed on June 6, 2018, Ag + Open Space had received nine applications for a total funding request of \$7.1 million. Applicant project locations were distributed throughout the county and from a variety of eligible entities. One application was deemed ineligible per the Program Guidelines, leaving eight eligible applications for a total request of \$6.9 million.

Application Review and Evaluation

During the application review process, an inter-disciplinary committee of Ag + Open Space staff and the Matching Grant Subcommittee (“Subcommittee”) reviewed and evaluated applications using the Program Guidelines evaluation criteria. The Subcommittee is comprised of three representatives from the Advisory Committee and two from the Fiscal Oversight Commission. Additionally, the Administrative and Fiscal Services Manager evaluated each applicant’s fiscal solvency/liquidity. The inter-disciplinary staff team and the Subcommittee met twice to discuss projects and to develop preliminary recommendations.

During the evaluation and review process, projects are considered individually to determine how well they fulfill the Program’s goals and criteria. Examples include an analysis of project readiness, match funding security, contribution toward geographic diversity, and public support. Through the evaluation process, staff and the Subcommittee may prioritize projects that protect new lands to increase the amount of urban open space as well as those that provide new opportunities for recreation, connections within and between communities and other protected lands, and habitat restoration. Throughout this process, staff and the Subcommittee were committed to following a consistent approach in its review, ,applying the same rationale across all funding applications and ultimately in the funding recommendations.

Staff and the Subcommittee have developed a suite of recommended projects and funding amounts for each project. Staff and the Subcommittee recommend funding five projects. These recommendations were presented at the Ag + Open Space Advisory Committee on September 27, 2018, and to the Fiscal Oversight Commission on October 4, 2018. The Advisory Committee and the Fiscal Oversight Commission supported the staff and Subcommittee recommendations.

Summaries of all applications, including attributes and considerations and funding recommendations can be found below.

Funding Recommendations

Of the eight eligible applications received, none were for projects in burned areas or for eligible projects that would aid in fire recovery efforts. Because the Program budget was increased to provide additional funding for projects located within the burn zone, and because no applications received involved burned areas, staff and the Subcommittee’s recommendation is to fund the most competitive projects in this cycle at a funding level that is historically consistent with previous funding cycle allocations, i.e., approximately \$2 million. Furthermore, staff and the Subcommittee recommend that any funds not allocated in the 2018 MGP cycle be retained for the next Program cycle for eligible projects located in areas that burned during the October 2017 fires. Staff anticipates that it will receive competitive applications in the next Program cycle that can be awarded to projects located in burned areas that will aid in recovery and rebuilding of community open spaces impacted by the devastating fires.

The five projects recommended for funding include two acquisition projects, two improvement – public access/recreational development, and one ‘combination’ project which includes both acquisition and improvement – public access/recreational development for a total recommended funding amount of \$2,426,943.

The table below reflects the funding recommendations for each application received. These recommendations reflect those of staff and the Subcommittee with support from the Advisory Committee and Fiscal Oversight Commission. Staff requests that the Board accept these recommendations as presented.

Projects Recommended

Project	Applicant/ Co- Applicant	Type of Project	Size (acres)	Funding Request	Recommendation
AmeriCorps Trail Development Project	City of Sebastopol	Improvement - Public Access / Recreation Development	12.4	\$126,943	\$126,943
Badger Park Russian River Access	City of Healdsburg	Improvement - Public Access / Recreation Development	20	\$1,000,000	\$500,000
Cooper Creek Addition - Taylor Mountain Regional Park & Open Space Preserve	Sonoma County Regional Parks	Acquisition	54	\$742,000	\$500,000
Helen Putnam Regional Park Extension	Earth Island Institute	Acquisition	44-58	\$1,000,000	\$800,000

Project	Applicant/ Co-Applicant	Type of Project	Size (acres)	Funding Request	Recommendation
McNear Peninsula Acquisition and Access Improvements	City of Petaluma / Friends of the Petaluma River	Combination: Acquisition & Improvement - Public Access / Recreation Development	20.8	\$750,000	\$500,000
TOTAL				\$3,618,943	\$2,426,943

Projects Not Recommended

Project	Applicant/ Co-Applicant	Type of Project	Size (acres)	Funding Request	Recommendation
Balletto Field Restoration	Laguna de Santa Rosa Foundation	Improvement - Restoration	64.9	\$124,257	ineligible
Clara's Garden	Windsor Historical Society / Town of Windsor	Improvement - Public Access/Recreation Development	2.2	\$133,339	\$0
La Cresta Ridge and Ravine	City of Petaluma / O.W.L.	Combination: Acquisition & Improvement - Public Access/Recreation Development	12.6	\$747,000	\$0
Mission Bell Farm	Blue Wing Adobe Trust	Acquisition	2.7	\$2,500,000	\$0
TOTAL				\$3,504,596	\$0

Next Steps

The Board's acceptance of projects into the Program does not in itself guarantee funding, but rather represents a commitment by Ag + Open Space to work with the project applicants to meet all Program requirements for the proposed grant. Project implementation will then occur in accordance with the Program Guidelines, including approval of a Matching Grant Agreement by the District's Board of Directors, following review of the proposed transaction by the District's Fiscal Oversight Commission.

The Matching Grant Agreement identifies the roles and responsibilities of the District and the grantee, and includes requirements that must be met in order for Ag + Open Space to disburse funds. The Matching Grant Agreement will require that the grantee conveys a Conservation Easement over the project's land to ensure the preservation of the property's open space values by prohibiting incompatible development, in perpetuity. A Recreation Covenant is also generally required of recreation

projects, ensuring that the project site will remain open to the public for park and open space use in perpetuity.

Ag + Open Space staff will continue to work with the Subcommittee, County Counsel and your Board to refine and improve the Program Guidelines, evaluation criteria, and application process in preparation for the next Program funding cycle.

Project Summaries

THE FOLLOWING MGP 2018 APPLICATIONS ARE RECOMMENDED FOR FUNDING

1. PROJECT: AmeriCorps Trail Development
APPLICANT: City of Sebastopol
LOCATION: Laguna de Santa Rosa near Morris St.
ACREAGE: 12.4 acres
FUNDING REQUEST: \$126,943
MATCH: \$126,943
SECURE: \$1,439 City in-kind project management
SECURE: \$87,079 City CIP Budget
SECURE: \$28,000 Laguna Foundation WPP grant
SECURE: \$10,425 City in-kind O&M
TOTAL MATCH: \$126,943

TOTAL PROJECT COST: \$253,886

SCOPE: The City of Sebastopol will develop new trails and access points to connect with the existing the AmeriCorps Trail. Project includes a new trail extension over Zimpher Creek to Hwy 12 and natural resource restoration components to be completed by the Laguna de Santa Rosa Foundation as a part of their WPP grant.

This project is recommended for full funding up to the \$126,943 request primarily for the following reasons:

- The project would result in an additional 12 acres protected near to other Ag + Open Space protected lands in the Laguna de Santa Rosa (Balletto Ranch, Tomodachi Park, Meadowlark Field, Laguna Trail), will provide new recreational opportunities, and include a natural resource restoration component.*
- The project demonstrates readiness to be completed within the MGP deadlines with secure match and 80% construction plans complete.*

2. PROJECT: Badger Park River Access
APPLICANT: City of Healdsburg
LOCATION: Badger Park, Heron Drive, Healdsburg
ACREAGE: 20 acres
FUNDING REQUEST: \$1,000,000
MATCH: \$1,000,000
SECURE: \$50,000 Community Services Capital Improvement Fund

SECURE: \$400,000 Park Impact Fund
SECURE: \$1,158,500 Bond proceeds
TOTAL MATCH: \$1,608,500 SECURE

TOTAL PROJECT COST: \$2,608,500 (MGP proposal is a part of a larger park redevelopment project that would not include any MGP funds.)

SCOPE: The City of Healdsburg will officially incorporate the Russian River into Badger Park, providing the City's first authorized river access point. The project may also include additional parking and/or a permanent restroom as a part of the river access improvements.

This project is recommended for funding for up to 50% of the \$1,000,000 request primarily for the following reasons:

- *The project will result in protection of as much as 20 acres and at least a quarter-mile of mature riparian vegetation along Russian River and will provide permanent public access for enjoyment of the River.*
- *The project has match secured and ready to contribute toward the implementation of the project.*

3. PROJECT: Cooper Creek Addition – Taylor Mountain Regional Park & Open Space Preserve

APPLICANT: Sonoma County Regional Parks
LOCATION: Santa Rosa at Allan Way and future Farmer's Lane Extension
ACREAGE: 54 acres
FUNDING REQUEST: \$742,000
MATCH: \$742,000
SECURE: \$5,000 Sonoma County Regional Parks Foundation
SECURE: \$2,000 Sonoma County Trails Council
SECURE: \$15,000 SCTC in-kind labor
SECURE: \$750 Redwood Empire Mountain Bike Alliance
SECURE: \$5,000 Redwood Empire Mountain Bike Alliance in-kind labor
SECURE: \$40,000 Regional Parks
PENDING: \$220,000 Habitat Conservation Fund, CA State Parks
PENDING: \$350,000 River Parkways, CA Natural Resources Agency
TOTAL MATCH: \$67,750 SECURE (\$637,350 including pending grant applications)

TOTAL PROJECT COST: \$1,484,000 (MGP Costs) + \$316,000 estimated for community engagement and master planning, environmental review, trail development.

SCOPE: Regional Parks seeks acquire 54 acres in Santa Rosa to expand Taylor Mountain Regional Park and Open Space Preserve.

This project is recommended for funding for up to 66% of the \$742,000 request primarily for the following reasons:

- *The project will result in 54 additional acres protected to be added to the 1,105 acre Taylor Mountain Regional Park and Open Space Preserve.*
- *The project has multiple benefits including scenic values, new recreational opportunities, and natural resource protection.*

4. PROJECT: Helen Putnam Regional Park Extension
 APPLICANT: Earth Island Institute (Kelly Creek Protection Project)
 LOCATION: D Street and Windsor Drive, Petaluma
 ACREAGE: 44-acre minimum / 58.65-acre maximum
 FUNDING REQUEST: \$1,000,000
 MATCH: \$3,010,000
 SECURE: \$3,000,000 Schwab Charitable donor-advised fund
 SECURE: \$10,000 individual donation
 SECURE: \$1,000,000 Sonoma Land Trust donor-advised fund (for development)
TOTAL MATCH: \$4,010,000 SECURE

TOTAL PROJECT COST: \$4,100,000 (for 44 acres) or \$11,000,000 (for 58.65 acres)

SCOPE: The Kelly Creek Project of the Earth Island Institute seeks to acquire either 44 or 58.65 acres in southwest Petaluma adjacent to Helen Putman Regional Park for eventual transfer to Sonoma County Regional Parks to expand the Regional Park.

This project is recommended for funding for up to 80% of the \$1,000,000 request primarily for the following reasons:

- *The project will protect at least 44 acres of land adjacent to Helen Putnam Regional Park and includes critical habitat for California Red Legged Frog.*
- *The project demonstrates readiness to proceed with a purchase and sales agreement, secure match, and funding set aside for initial park development and/or operations and maintenance.*

5. PROJECT: McNear Peninsula Acquisition + Access
 APPLICANT: City of Petaluma + Friends of the Petaluma River (FOPR)
 LOCATION: McNear Peninsula, Petaluma
 ACREAGE: 20.75 acres
 FUNDING REQUEST: \$750,000
 MATCH: \$750,000
 ANTICIPATED: \$27,000 City in-kind
 ANTICIPATED: \$346,550 FOPR
 PENDING: \$477,450 Coastal Conservancy
TOTAL MATCH: \$851,000 anticipated and pending (for development)

TOTAL PROJECT COST: \$1,500,000

SCOPE: The City of Petaluma seeks to acquire 20.75 acres of McNear Peninsula to be added to Steamer Landing Park. The City and co-applicant Friends of the Petaluma River intend to match funds for the project development of the parcel for low-intensity recreation.

This project is recommended for funding for up to 66% of the \$742,000 request primarily for the following reason:

- *The project will result in an additional 20.75 acres of protected land on the McNear Peninsula, providing new opportunities for low-intensity recreation and education.*

THE FOLLOWING MGP 2018 APPLICATIONS ARE NOT RECOMMENDED FOR FUNDING

- 1. PROJECT: Balletto Field Wetland Restoration Project**
APPLICANT: Laguna Foundation
LOCATION: Balletto Field, Sebastopol (Laguna Trail)
ACREAGE: 64.9 acres
FUNDING REQUEST: \$124,257
MATCH: \$126,027
SECURE: \$75,000 WPP Grant
SECURE: \$37,027 Regional Parks
SECURE: \$6,200 Laguna Foundation (not included in match calculation)
ANTICIPATED: \$14,000 volunteer in-kind labor
TOTAL: \$112,027 SECURE (\$126,027 incl. anticipated)

TOTAL PROJECT COST: \$250,284

Project is considered ineligible as the Conservation Easement on Balletto Field was acquired through the acquisition of a conservation easement outside of the MGP. This is considered ineligible per the MGP Guidelines.

This project is not recommended for funding as it is an ineligible project.

- 2. PROJECT: Clara's Garden Restoration**
APPLICANT: Windsor Museum + Historical Society and Town of Windsor
LOCATION: Clara's Garden at the Hembree House and Museum, Windsor
ACREAGE: Approximately 0.5 acres
FUNDING REQUEST: \$133,339
MATCH: \$133,339
TOTAL MATCH: \$133,339 SECURE Windsor Museum and Historical Society

TOTAL PROJECT COST: \$266,678

SCOPE: The Town of Windsor and the Windsor Historical Society would provide improved access, including additional ADA access to Clara's Garden from the Windsor Creek Trail and the Windsor History Museum and would add park amenities such as seating areas, replacing and enhancing garden plantings and restoration of a historic outdoor fireplace.

This project is not recommended for funding for the following reasons:

- *Staff and the Subcommittee recommended funding for the most competitive projects, keeping the total award to around \$2.5 million in order to reserve funding for projects located in burned areas in the 2020 funding cycle.*

- 3. PROJECT: La Cresta Ridge and Ravine**
APPLICANT: City of Petaluma / OWL (as fiscal sponsor of West Petaluma Hills Coalition)

LOCATION: La Cresta Drive, Petaluma
 ACREAGE: 13.61 acres
 FUNDING REQUEST: \$747,000
 MATCH: \$747,000
 SECURED: \$4,532 Cash and in-kind donations
 SECURED: \$3,000 Rose Foundation for improvement through 12/2018
 ANTICIPATED: \$21,750 City in-kind
 ANTICIPATED: \$6,750 WPH, SLCRR
 ANTICIPATED: \$52,000 Grants, donations, volunteers
 ANTICIPATED: \$50,000 Pledges from WPH
 PENDING: \$50,000 Joseph and Vera Long Foundation
 TOTAL: \$7,532 SECURE (\$188,032 with anticipated and pending)

TOTAL PROJECT COST: \$1,494,000

SCOPE: The City of Petaluma and the community groups Save La Cresta Ridge and Ravine and West Petaluma Hills Coalition seek to acquire 13.6 acres in south west Petaluma.

This project is not recommended for funding for the following reasons:

- *Staff and the Subcommittee recommended funding for the most competitive projects, keeping the total award to around \$2.5 million in order to reserve funding for projects located in burned areas in the 2020 funding cycle.*

4. PROJECT: Mission Bell Farm
 APPLICANT: Blue Wing Adobe Trust
 LOCATION: East Spain Street, Sonoma
 ACREAGE: 2.72 acres
 FUNDING REQUEST: \$2,500,000
 MATCH: \$2,500,000 (for 1:1 match but purchase agreement = \$7M)
 TOTAL MATCH: \$ 2.3 million anticipated in pledges (as of 9/18/18)

TOTAL PROJECT COST: \$7,000,000

SCOPE: The Blue Wing Adobe Trust seeks to acquire 2.7 acres in downtown Sonoma for open space.

This project is not recommended for funding for the following reasons:

- *Staff and the Subcommittee recommended funding for the most competitive projects, keeping the total award to around \$2.5 million in order to reserve funding for projects located in burned areas in the 2020 funding cycle.*

Prior Board Actions:

October 25, 2016: The Board accepted seven projects into the Program for a total funding amount of \$3,408,124.

October 14, 2014: The Board accepted seven projects into the Program for a total funding amount of \$2,582,715.

September 18, 2012: The Board accepted staff and subcommittee funding recommendations and accepted six projects into the Program for a total of \$2,000,000.

December 6, 2011: The Board approved revisions to the Program.

Strategic Plan Alignment Goal 1: Safe, Healthy, and Caring Community

Project implemented by the Matching Grant Program will promote healthy communities by providing permanently protected lands within and near Sonoma County’s cities and unincorporated communities.

Fiscal Summary

Expenditures	FY 18-19 Adopted	FY 19-20 Projected	FY 20-21 Projected
Budgeted Expenses	0		
Additional Appropriation Requested			
Total Expenditures			

Funding Sources

General Fund/WA GF			
State/Federal			
Fees/Other			
Use of Fund Balance			
Contingencies			
Total Sources	0		

Narrative Explanation of Fiscal Impacts:

A total of \$2,426,943 in funding is being recommended for approval. The fiscal impacts of this action will not be realized until the District completes negotiations of all grant related requirements and they are authorized by the Board to execute a Matching Grant Agreement. No budget adjustment is required for the proposed increases. The funding for each project will be budgeted within the fiscal year it is anticipated for completion.

Staffing Impacts

Position Title (Payroll Classification)	Monthly Salary Range (A – I Step)	Additions (Number)	Deletions (Number)

Narrative Explanation of Staffing Impacts (If Required):

Attachments:

1. Map of all Matching Grant Program Projects including 2018 Applications
2. Map of Projects Recommended for 2018 Program Cycle

Related Items "On File" with the Clerk of the Board:

1. 2018 Matching Grant Program Application
2. 2018 Matching Grant Program Guidelines
3. 2018 Matching Grant Program Applications for the following projects:
 - a. AmeriCorps Trail
 - b. Badger Park River Access
 - c. Balletto Field Restoration
 - d. Clara's Garden Restoration
 - e. Cooper Creek Addition – Taylor Mountain Regional Park and Open Space Preserve
 - f. Helen Putnam Regional Park Extension
 - g. La Cresta Ridge and Ravine
 - h. McNear Peninsula Acquisition and Access
 - i. Mission Bell Farm

Matching Grant Program 2018 Cycle

Applications, Active
& Completed Projects

- + 2018 MGP Applications
- ◇ Active Matching Grant Projects
- Completed or Executed Matching Grant Project
- Unincorporated Towns
- ▭ Urban Growth Boundary
- ▭ Incorporated City Land

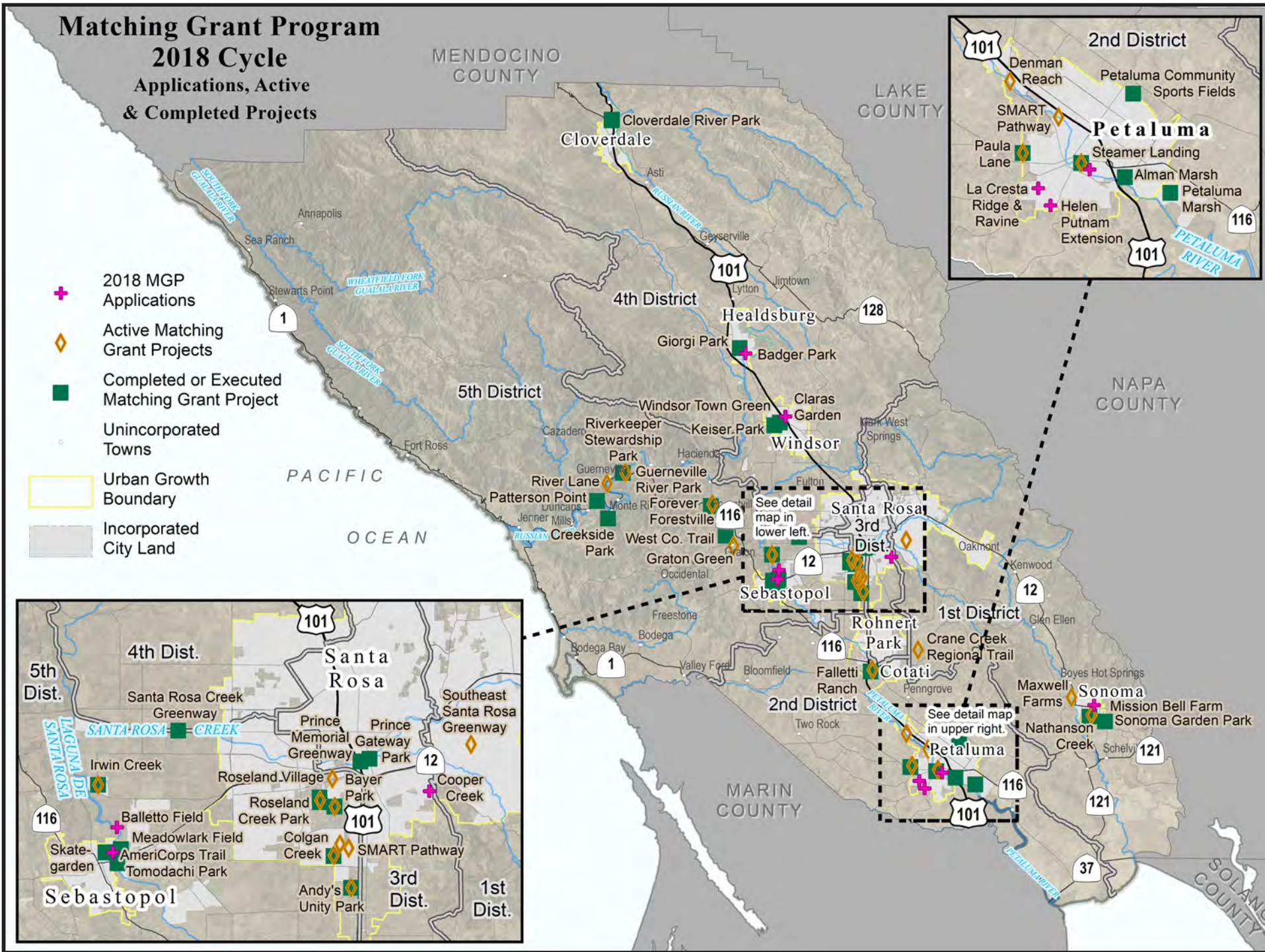

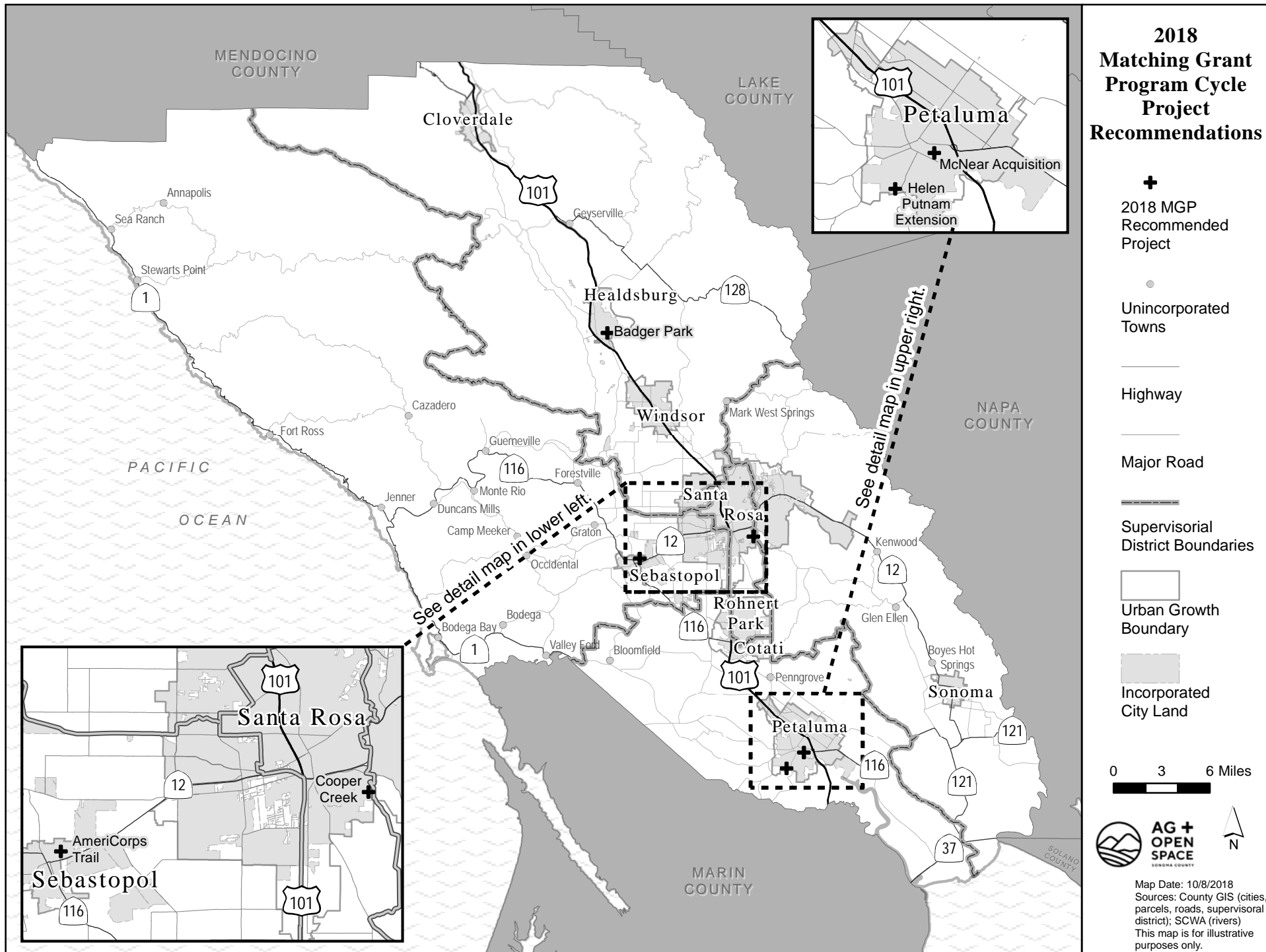

2018 Matching Grant Program Cycle Project Recommendations

- +** 2018 MGP Recommended Project
- Unincorporated Towns
- Highway
- Major Road
- Supervisorial District Boundaries
- Urban Growth Boundary
- Incorporated City Land



Map Date: 10/8/2018
 Sources: County GIS (cities, parcels, roads, supervisorial district); SCWA (rivers)
 This map is for illustrative purposes only.



**AG +
OPEN
SPACE**
SONOMA COUNTY

2018 MATCHING GRANT PROGRAM

From the Ag + Open Space Expenditure Plan:

*“5. Other open space projects include, but are not limited to, **urban open space** and **recreation projects within and near incorporated cities** and other **urbanized** areas of Sonoma County. Funds for these projects shall be available to cities, the County, and other entities through a **matching grant program**, with **preference** given to **acquisition** and **development** projects that **link communities**. Examples of these projects include creek restoration and enhancement, such as along the Petaluma River, Santa Rosa Creek and Laguna de Santa Rosa, trails, athletic fields, and urban greenspace.”*

ELIGIBILITY + PROGRAM REQUIREMENTS



- **Eligible Applicants**

- ✓ Public Agencies (e.g., City, County, Park District)
- ✓ 501(c)3 Non-profits

- **Eligible Projects**

- ✓ Acquisition
- ✓ Improvement
- ✓ Combination Projects

2018 MGP PROCESS



- Outreach and public workshop
- Application deadline – June 6
- Completeness, eligibility + financial review
- Information requests and site visits
- Staff & Subcommittee meetings
- Managers' meeting
- Advisory Committee – September 27
- Fiscal Oversight Commission- October 4
- Board of Directors – November 13

EVALUATION PROCESS



Eligible Projects:

- Protect urban open space
- Create connections within and between communities
- Provide recreational opportunities in urban areas
- Restore and enhance significant natural habitat

Competitive Projects:

- Have secure match
- Are ready for implementation/acquisition
- Fulfill an identified need
- Have broad community support

Matching Grant Program

2018 Cycle

Applications, Active
& Completed Projects

- 2018 MGP Applications
- Active Matching Grant Projects
- Completed or Executed Matching Grant Project
- Unincorporated Towns
- Urban Growth Boundary
- Incorporated City Land

MENDOCINO COUNTY

LAKE COUNTY

2nd District



Cloverdale

4th District

101

Healdsburg

128

5th District

1

Giorgi Park

Badger Park

Windsor Town Green

Claras Garden

Keiser Park

Windsor

Riverkeeper Stewardship Park

Guerneville River Park

Forestville

West Co Trail

Graton Green

Creekside Park

See detail map in lower left.

116

12

Santa Rosa

3rd Dist.

Sebastopol

1st District

12

Rohnert Park

Crane Creek Regional Trail

Falletti Ranch

Cotati

2nd District

Two Rock

See detail map in upper right.

116

101

Petaluma

NAPA COUNTY

Sonoma

Mission Bell Farm

Sonoma Garden Park

Nathanson Creek

Maxwell Farms

37

MARIN COUNTY

SOLANO COUNTY

PACIFIC

OCEAN



Matching Grant Program 2018 Cycle Applications

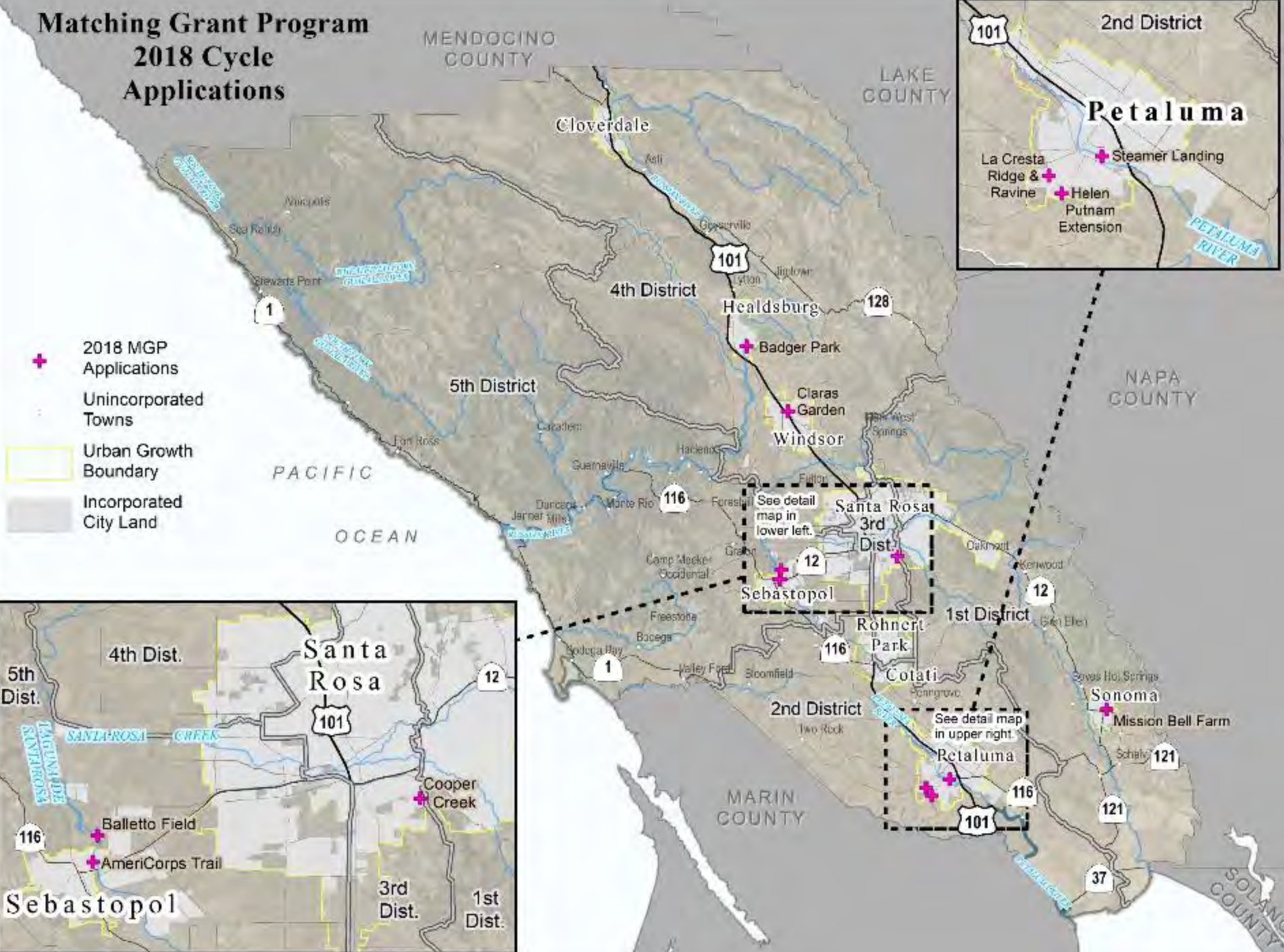

- + 2018 MGP Applications
- Unincorporated Towns
- Urban Growth Boundary
- Incorporated City Land



AMERICORPS TRAIL DEVELOPMENT



AMERICORPS TRAIL DEVELOPMENT

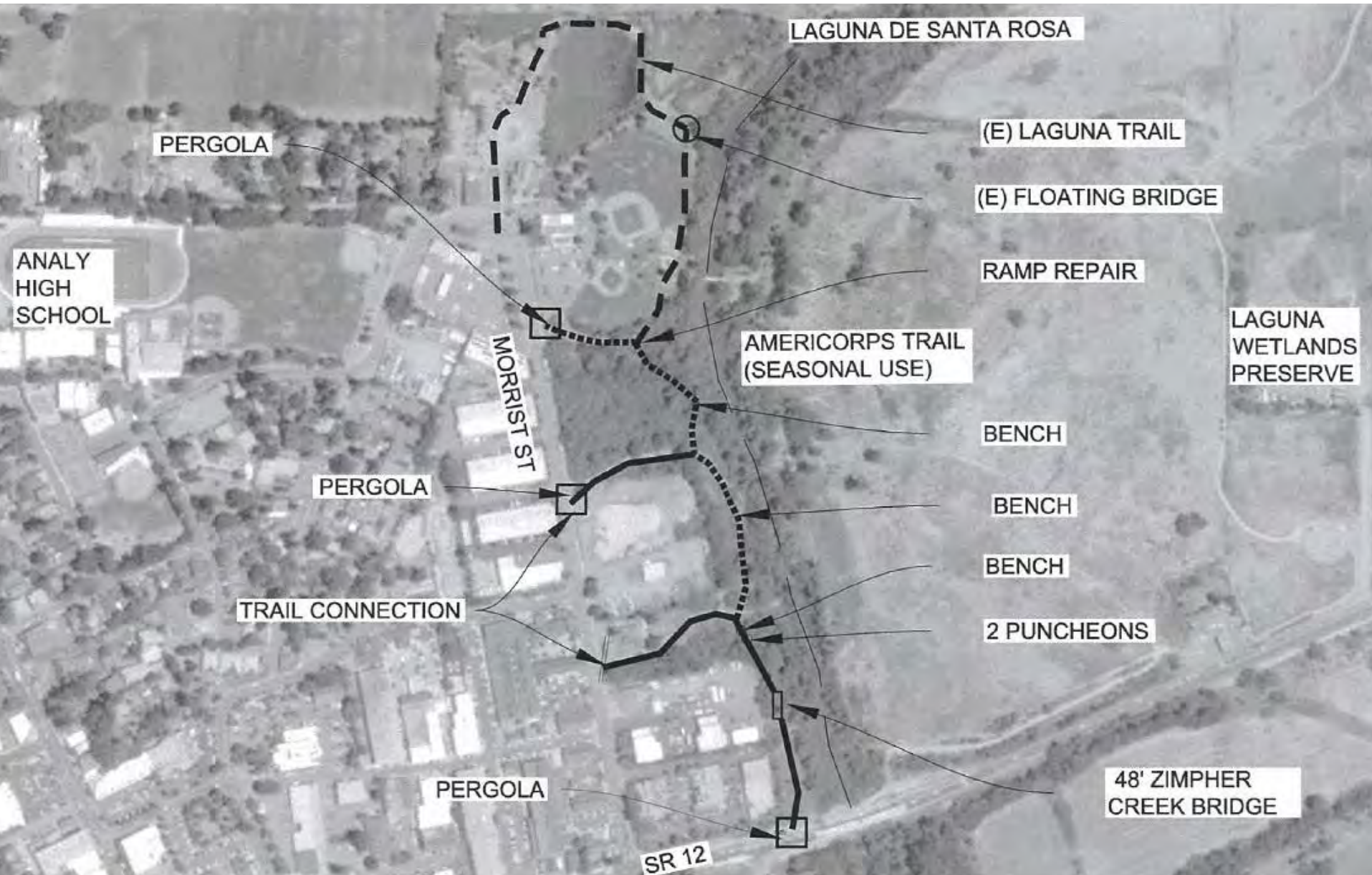



AG +
OPEN
SPACE
SONOMA COUNTY



BADGER PARK RIVER ACCESS





AG +
OPEN
SPACE
SONOMA COUNTY





COOPER CREEK ADDITION Taylor Mountain

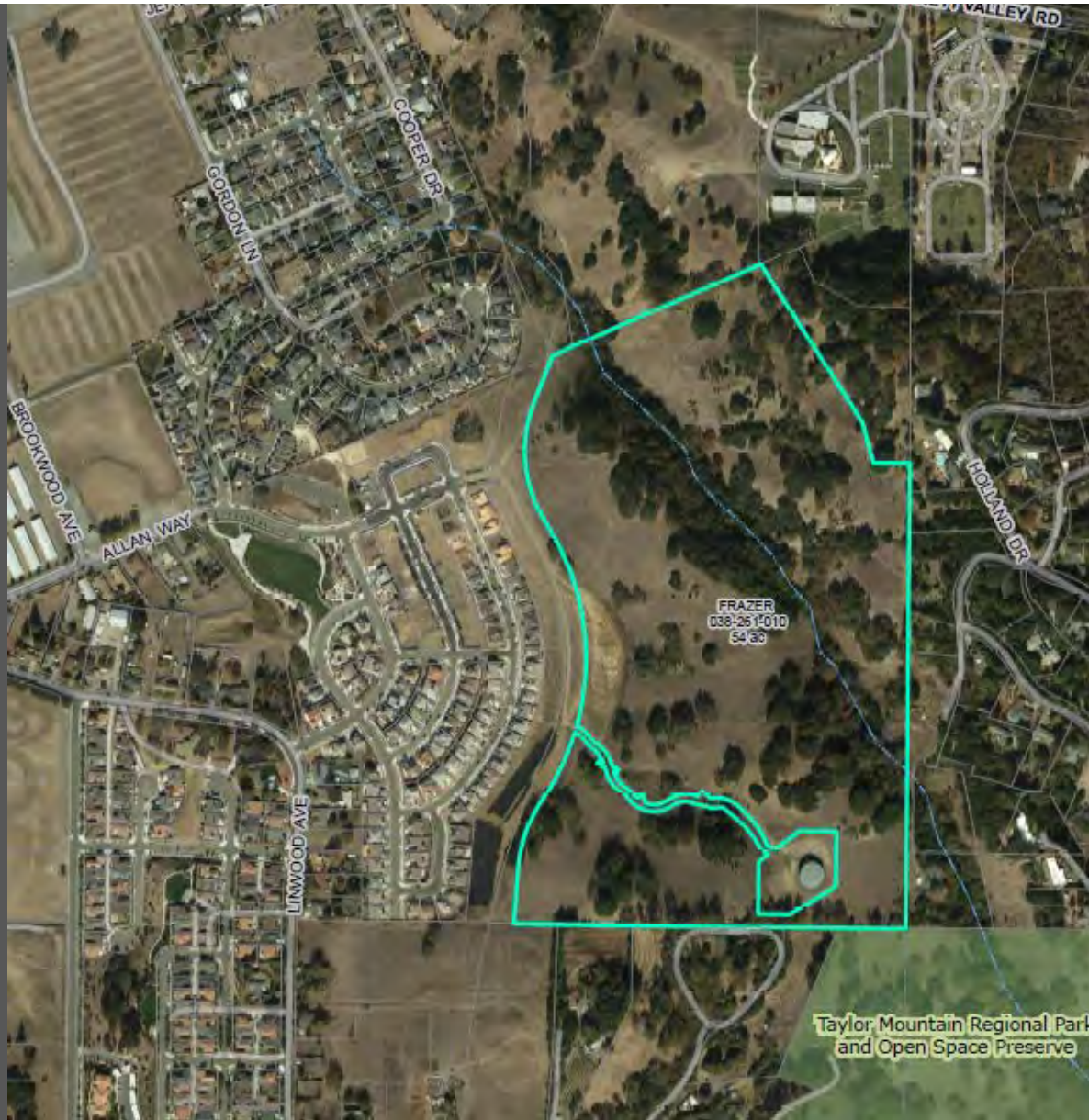



AG +
OPEN
SPACE
SONOMA COUNTY





HELEN PUTNAM REGIONAL PARK EXTENSION







AG +
OPEN
SPACE
SONOMA COUNTY



MCNEAR PENINSULA ACQUISITION + ACCESS





AG +
OPEN
SPACE
SONOMA COUNTY





MGP 2018 BUDGET



- **Program Budget typically around \$2 million every other year.**
- **2018 Program Funding set at \$4 million to provide additional funding for projects in burned areas.**
- **Final funding amounts determined by the Ag + Open Space Board of Directors.**

MGP 2018 RECOMMENDATIONS



Advisory Committee, Fiscal Oversight Commission, Subcommittee, & staff recommend \$2,426,943 for 5 projects.

- **2 Acquisition projects.**
- **2 Improvement projects.**
- **1 Combination (Acquisition + Improvement)**

Remaining funds from 2018 MGP budget would “roll-over” to 2020 MGP cycle for eligible projects in burned areas.

Project	Applicant/Co-Applicant	Type of Project	Size (acres)	Funding Request	Recommendation
AmeriCorps Trail Development Project	City of Sebastopol	Improvement - Public Access/Recreation Development	12.4	\$126,943	\$126,943
Badger Park Improvements and Russian River Access	City of Healdsburg	Improvement - Public Access/Recreation Development	20	\$1,000,000	\$500,000
Cooper Creek Addition - Taylor Mountain Regional Park & Open Space Preserve	Sonoma County Regional Parks	Acquisition	54	\$742,000	\$500,000
Helen Putnam Regional Park Extension	Earth Island Institute	Acquisition	44-58	\$1,000,000	\$800,000
McNear Peninsula Acquisition and Access Improvements	City of Petaluma / Friends of the Petaluma River	Acquisition & Improvement - Public Access/Recreation Development	20.8	\$750,000	\$500,000

RECOMMENDED BOARD ACTION



**Accept Recommendations for
Projects and Funding Amounts
for the 2018 Matching Grant
Program Cycle**

Project	Applicant/Co-Applicant	Type of Project	Size (acres)	Funding Request	Recommendation
AmeriCorps Trail Development Project	City of Sebastopol	Improvement - Public Access/Recreation Development	12.4	\$126,943	\$126,943
Badger Park Improvements and Russian River Access	City of Healdsburg	Improvement - Public Access/Recreation Development	20	\$1,000,000	\$500,000
Cooper Creek Addition - Taylor Mountain Regional Park & Open Space Preserve	Sonoma County Regional Parks	Acquisition	54	\$742,000	\$500,000
Helen Putnam Regional Park Extension	Earth Island Institute	Acquisition	44-58	\$1,000,000	\$800,000
McNear Peninsula Acquisition and Access Improvements	City of Petaluma / Friends of the Petaluma River	Acquisition & Improvement - Public Access/Recreation Development	20.8	\$750,000	\$500,000



County of Sonoma Agenda Item Summary Report

Clerk of the Board
575 Administration Drive
Santa Rosa, CA 95403

Agenda Item Number: 50
(This Section for use by Clerk of the Board Only.)

To: Board of Supervisors

Board Agenda Date: November 13, 2018

Vote Requirement: Majority

Department or Agency Name(s): Board of Supervisors

Staff Name and Phone Number:

James Gore 707-565-2241

Supervisorial District(s):

Fourth

Title: Fee Waiver

Recommended Actions:

Approve request for the Pacific Coast Air Museum for a fee waiver in the amount of \$650.00 for the Permit Sonoma event permit fee of \$650.00. The Pacific Coast Air Museum is a historical and cultural organization that has an annual Santa Claus Fly- In. The museum would like a fee waiver to bring the cost of this event within their budget.

Executive Summary:

Discussion:

Prior Board Actions:

Strategic Plan Alignment Goal 1: Safe, Healthy, and Caring Community

Fiscal Summary			
Expenditures	FY 18-19 Adopted	FY 19-20 Projected	FY 20-21 Projected
Budgeted Expenses			
Additional Appropriation Requested	650.00		
Total Expenditures			
Funding Sources			
General Fund/WA GF			
State/Federal			
Fees/Other			
Use of Fund Balance			
Contingencies	650.00		
Total Sources	650.00		
Narrative Explanation of Fiscal Impacts:			
Staffing Impacts			
Position Title (Payroll Classification)	Monthly Salary Range (A – I Step)	Additions (Number)	Deletions (Number)
Narrative Explanation of Staffing Impacts (If Required):			
Attachments:			
Related Items "On File" with the Clerk of the Board:			
Fee Waiver/Board Sponsorship Form			



County of Sonoma Agenda Item Summary Report

Clerk of the Board
575 Administration Drive
Santa Rosa, CA 95403

Agenda Item Number: 56
(This Section for use by Clerk of the Board Only.)

To: Board of Supervisors,

Board Agenda Date: November 13, 2018

Vote Requirement: Informational Only

Department or Agency Name(s): County Administrator's Office

Staff Name and Phone Number:

Niki Berrocal 707-565-2431

Supervisorial District(s):

All

Title: County of Sonoma Five Year Budget Improvement Plan 2019-2023
Five Year Fiscal Forecast FY 2018/19-FY 2022/23

Recommended Actions:

Receive and accept the County of Sonoma Five Year Budget Improvement Plan 2019-2023 and Five Year Fiscal Forecast FY 2018/19-FY 2022/23.

Executive Summary:

During the FY 2017/18 budget policy workshop, the Board of Supervisors directed staff to achieve a structurally balanced budget within four years. Shortly after the budget policy was adopted, the Sonoma Complex wildfires hit Sonoma County and destroyed 5,300 homes, 105 business, and took 24 lives. Given the County's recovery challenges from the wildfires and likely economic reset (as indicated by Vanguard in a recent New York Times article) in the coming years, it is important to develop a resilient and sustainable budget improvement plan over the next five years.

The Operations and Budget team have prepared a preliminary 5-year fiscal forecast (FY 2018/19 through FY 2022/23) that provides an outlook of the County's general fund financial capacity. The Operations and Budget team has also prepared a 5-year Budget Improvement Plan to move the County towards a budget that is:

- Fiscally Sustainable
- Transparent
- Strategically Aligned
- Performance Based

Discussion:

General Fund Fiscal Outlook

In advance of developing the budget, a fiscal projection of the General Fund operating budget is completed. The fiscal projections are developed using previous actuals and select current year revenue estimates. Staff considers impacts that may influence the County's financial health, including assessed property valuations, supplemental property tax growth, and debt obligations.

The forecast is neither a spending plan nor a projection of future policy decisions at the federal, state, or local level. Rather, the General Fund outlook is an illustration of known sources and uses for existing levels of County General Fund services and its annual investment.

At this time, based on FY 2017/18 actual revenue activity, as well as recent property value assessment information from the County Assessor's team, the updated County fiscal forecast assumes improved County General Fund Property Tax revenue growth of 4.1% for FY 2018/19, and future year property tax growth preliminary estimates of 4%; 3.5%; 3%; and 2.5% from FY 2019/20 through FY 2022/23.

Growth estimates in the outer years are tempered by several factors including fire recovery, the county's low housing inventory, and the aforementioned potential economic reset. Proposition 13 limits property valuation assessment to a 2% inflation factor, as long as properties are not sold.

Assumptions built into the FY 2018/19 Recommended Budget include (1) no cost of living adjustment for salaries and benefits, (2) flat internal service rates, (3) \$5.1 million of State property tax backfill, (4) new collection assumption for Transient Occupancy Tax based on FY 2017/18 actuals, and (5) remove all one-time revenues and expenditures. The five year forecast includes updated FY 2018/19 projected amounts that account for new information including: higher rate of growth from 2.5% to 4.1% on the assessment rolls; and new memorandums of understanding with bargaining units that were negotiated in 2018.

Attachment A shows the current five-year General Fund revenue and expenditure projections. Even with the benefit of property tax growth rate better than expected, the current projection shows that the FY 2018/19 Recommended Budget relies on utilizing \$2.7 million of General Fund Reserves to create a balanced Recommended Budget.

The 5-year projections show projected budget deficits in the following years:

- FY 18/19 \$ 2,950,691
- FY 19/20 \$ 2,617,084
- FY 20/21 \$ 3,195,231
- FY 21/22 \$ 5,224,414
- FY 22/23 \$ 8,602,118

Overall, FY 2017/18 unaudited actual expenses outpace revenues and when compared to FY 2016/17 actuals, FY 2017/18 revenues grew by 2% versus expenditure growth of 5%. As the organization transitions from reliance on previous yearend savings to a structurally balanced budget based on actuals, it is critical to align ongoing expenditures with ongoing revenues.

Staff will return to the Board on December 11th with the FY 2019/20 budget framework tools for balancing the budget that includes General Fund allocations based on revenue estimates considering ongoing operational expenditure trends. Given the projected \$3.2 million deficit for FY 2019/20, staff

will return with recommendations on different strategies and tools. One such strategy may be a recommendation to adopt a hiring freeze.

The five year forecast helps set the stage for the five year Budget Improvement Plan.

Long Term Budget Improvement Plan

The County Administrator's Office considered previous Board direction and input from internal stakeholders to create a five year Budget Improvement Plan. The purpose of the plan is to build financial resiliency so that the County can continue to focus on the highest priorities, while meeting our legal mandates. The plan identifies the following five goals:

- **Goal 1: Foster a balanced budget model that is sustainable for long-term financial planning, and is resilient to swings in revenues and expenditures.**
Under a balanced budget model, the County's ongoing revenues meet ongoing expenditures. A desired outcome is that the County is able to maintain community services and meet priority needs, while at the same time building General Fund Reserves to meet the Board's policy (two months operating revenues).
- **Goal 2: Leverage resources through enhanced integration and collaboration.**
Achieving this goal requires County departments and agencies to work collaboratively and become integrated around service delivery. True integration breaks down silos and allows services to be provided efficiently and seamlessly. The organizational benefit of true integration eliminates duplication of efforts and allows for shared resources to create stronger ties to each other and the services provided by the County as a whole.
- **Goal 3: Inventory county government services and identify alignment with Board priorities.**
The desired outcome of this goal is that the County departments and agencies consistently identify services provided both internally and externally along with the policy guidance (mandated/discretionary) for providing those services. The desired outcome is to understand what is being provided, by whom, at what level, and where it is prioritized. This exercise lays the foundation for the Board to prioritize limited funding toward mandated services and our highest priorities, while identifying key performance indicators as well as data for decision making.
- **Goal 4: Harness performance metrics that provide data for decision making.**
The desired outcome of this goal includes the identification of key performance metrics that inform the public about how well services are being delivered, what resources are needed to deliver those services, and inform budget decisions that may affect service levels and delivery. Publishing key performance metrics in the budget by FY 2021/22 will help the County assess the effectiveness of service delivery output vs. outcome and identify trends.
- **Goal 5: Present budget documents that are transparent, understandable, and inform the public and decision makers, and implement non-profit principles to achieve priority outcomes.**
The desired outcome of this goal aligns both the organization and community toward common purposes and priorities, better outcomes through enhanced partnership with non-profit service providers, educate both the County organization and the public about the budget, and provide multiple opportunities for input.

The Budget Improvement Plan is Attachment B and includes improvements to be implemented over the next five years to achieve the five goals listed above.

Budget Planning Efforts for FY 2019/20

Starting after the FY 2018/19 budget development cycle, the Operations and Budget team conducted a facilitated debrief and series of planning sessions. The objective of these sessions were to identify the structure for FY 2019/20, plan for effective and efficient processes, create a common understanding of process and tools, improve communication at all levels, and develop a long term vision for the next five years.

To improve communications and provide enhanced customer service, the Operations and Budget team created a new countywide team including Administrative Fiscal Officers and key financial staff from all County departments. This countywide fiscal team works together to address budget and finance issues, as well as innovations. In addition to the countywide fiscal team, an internal services project team has been created to assess internal services from the six internal service provider departments (County Counsel, General Services, Human Resources, Information Systems, Auditor-Controller-Treasurer Tax Collector, and the County Administrator's Office). The internal services project team includes customer departments too (Probation, Health Services, Sheriff, Human Services, Transportation and Public Works, and Child Support Services).

The internal services project team is completing a service inventory including identification of service mandates, a review of best practices, and have engaged in a benchmarking effort.

One of the initial outcomes is standardizing cost recovery goals to ensure fair and equitable practices countywide. The following internal services pricing principles will be included in the County Administrator's Administrative Policies:

1. Encouraging desirable organization level utilization behaviors.
2. Supporting sustainable services and service levels.
3. Review existing, new and expanded costs for market efficiencies.
4. Utilizing clear and effective allocation bases.
5. Complying with state and federal guidelines, especially for costs attributed to county and agency programs financed with state and/or federal funds.
6. Transparently accounting for costs in the appropriate place.
7. Treating similar types of costs in a consistent manner.
8. Maintaining documentation of costs associated with delivery of services, as well as the calculations completed to arrive at the final cost allocation.
9. Simplifying presentation so that customers understand the relationship between the costs incurred and the benefit received.

The committee is currently reviewing internal service rates and will have certain efficiencies built into the FY 2019/20 budget development cycle, such as fleet rates adjusting to reflect vehicle utilization, lowering collection toward replacement of non-public safety vehicles from 100% to 75%, and a streamlined facility maintenance methodology. The internal services project team is also developing a communication and improvement plan to be implemented in subsequent years. To continue implementation of best practices, it is important to establish this group as a standing committee to ensure cross departmental coordination and communication in the development of annual internal

service rates. The team will also explore a rate stabilization fund for General Fund departments to help solve for large swings in rates.

Next Steps

The County Administrator will return to the Board on December 11th, 2018 with the FY 2019/20 budget framework, updated five year fiscal illustrations, and known financial impacts to kick off the FY 2019/20 budget development cycle.

Prior Board Actions:

June 17th, 2016 – Adoption of a structurally balanced budget financial policy.

Strategic Plan Alignment Goal 2: Economic and Environmental Stewardship

Fiscal Summary

Expenditures	FY 18-19 Adopted	FY 19-20 Projected	FY 20-21 Projected
Budgeted Expenses			
Additional Appropriation Requested			
Total Expenditures			

Funding Sources

General Fund/WA GF			
State/Federal			
Fees/Other			
Use of Fund Balance			
Contingencies			
Total Sources			

Narrative Explanation of Fiscal Impacts:

--	--	--	--

Staffing Impacts

Position Title (Payroll Classification)	Monthly Salary Range (A – I Step)	Additions (Number)	Deletions (Number)

Narrative Explanation of Staffing Impacts (If Required):

Attachments:

Attachment A: Five-Year Fiscal Forecast FY 2018/19-FY 2022/23

Attachment B: Budget Improvement Plan 2019-2023

Related Items "On File" with the Clerk of the Board:

General Fund 5 year Fiscal Forecast - General Fund Only - Attachment A

GENERAL FUND ONLY FORECAST	FY 18-19	FY 18-19	FY 19-20	FY 20-21	FY 21-22	FY 22-23
	Budget	Projected	Projected	Projected	Projected	Projected
Taxes	273,934,468	282,423,976	287,651,286	297,122,025	305,497,291	312,749,766
Secured Property Tax	238,526,883	246,415,518	256,272,138	265,241,663	273,198,913	280,028,886
Assumed State Backfill ¹	5,149,900	5,149,900	-	-	-	-
Redevelopment Increment	(11,163,000)	(11,163,000)	(11,609,520)	(12,015,853)	(12,376,329)	(12,685,737)
Residual Property Tax RPTTF	3,000,000	3,000,000	3,120,000	3,229,200	3,326,076	3,409,228
Unsecured Property Tax	5,615,000	5,615,000	5,839,600	6,043,986	6,225,306	6,380,938
Supplemental Property Tax	2,960,000	2,960,000	3,078,400	3,186,144	3,281,728	3,363,772
Documentary Transfer Tax	5,000,000	5,000,000	5,000,000	5,000,000	5,000,000	5,000,000
Sales Tax	19,830,000	19,843,000	20,180,331	20,523,397	20,810,724	21,102,074
TOT	4,971,415	5,559,288	5,726,067	5,869,218	5,986,603	6,106,335
Other Taxes	44,270	44,270	44,270	44,270	44,270	44,270
Non-Tax Revenues	186,054,077	186,879,695	181,321,220	180,453,910	179,316,915	181,703,235
Licenses/Permits/Franchises	21,223,802	21,223,802	21,223,802	17,723,802	14,223,802	14,223,802
State and Federal Funds	76,895,215	77,626,742	79,185,190	80,776,101	82,095,128	83,436,385
Fines/Forfeitures/Penalties	9,487,718	9,487,718	7,887,718	7,887,718	7,887,718	7,887,718
Use of Money/Property	5,774,584	5,774,584	5,789,021	5,803,493	5,818,002	5,832,547
Charges for Services	47,543,903	47,637,994	48,383,372	49,225,079	50,067,094	50,908,284
Miscellaneous Revenues	3,876,037	3,876,037	3,569,378	3,605,071	3,641,122	3,677,533
Other Financing Sources ²	19,463,528	19,463,528	14,990,461	15,140,366	15,291,769	15,444,687
Special Items	292,280	292,280	292,280	292,280	292,280	292,280
Release of SB 90 Audit Reserve	1,497,011	1,497,011	-	-	-	-
Total Sources	459,988,545	469,303,671	468,972,506	477,575,935	484,814,206	494,453,001
Wages & Benefits	332,264,634	341,374,998	341,875,226	349,938,891	358,249,459	366,663,782
Wages and Benefits subject to CPI ³	213,683,428	220,227,467	218,491,305	223,407,360	228,434,025	233,573,791
Pension	39,484,356	40,693,562	41,180,209	42,948,899	44,793,555	46,717,438
Pension Obligation Bond	24,543,290	24,543,290	25,956,110	26,990,527	28,077,520	29,068,013
Other Post Employment Benefits	14,974,343	14,974,343	15,311,265	15,655,769	16,008,024	16,368,204
Medical Benefits	24,472,197	25,829,316	25,829,316	25,829,316	25,829,316	25,829,316
Other Capitated Benefits	15,107,020	15,107,020	15,107,020	15,107,020	15,107,020	15,107,020
Non-Salary & Benefit Expenses	127,723,910	130,879,364	129,714,364	130,832,275	131,789,161	136,391,337
Services & Supplies	119,832,341	120,848,351	119,057,196	119,023,912	118,989,629	122,559,318
Other Charges	24,549,482	24,592,083	25,040,472	25,541,281	26,052,107	26,573,149
Fixed Assets	4,762,038	4,762,038	4,000,000	4,000,000	4,000,000	4,000,000
Other Financing Uses	76,223,034	80,544,600	77,136,818	78,590,404	80,083,981	81,618,792
<i>Roads (ongoing adjt. w/growth)</i>	<i>15,137,637</i>	<i>15,137,637</i>	<i>15,440,390</i>	<i>15,749,198</i>	<i>16,064,181</i>	<i>16,385,465</i>
<i>In Home Support Services</i>	<i>24,696,857</i>	<i>24,696,857</i>	<i>25,561,247</i>	<i>26,455,891</i>	<i>27,381,847</i>	<i>28,340,211</i>
<i>Capital Projects/Facilities Maintenance</i>	<i>7,966,229</i>	<i>12,287,795</i>	<i>11,121,683</i>	<i>11,121,683</i>	<i>11,121,683</i>	<i>11,121,683</i>
<i>Other Transfers</i>	<i>26,921,190</i>	<i>26,921,190</i>	<i>23,497,366</i>	<i>23,732,340</i>	<i>23,969,663</i>	<i>24,209,360</i>
<i>Non-Transfer Other Financing Uses</i>	<i>1,501,121</i>	<i>1,501,121</i>	<i>1,516,132</i>	<i>1,531,293</i>	<i>1,546,606</i>	<i>1,562,072</i>
Reimbursements	(101,169,872)	(101,169,872)	(100,520,121)	(101,323,322)	(102,336,555)	(103,359,921)
Contingencies	3,526,887	1,302,164	5,000,000	5,000,000	5,000,000	5,000,000
Total Uses	459,988,545	472,254,362	471,589,591	480,771,166	490,038,620	503,055,119
Total Surplus (Deficit)⁴	0	(2,950,691)	(2,617,084)	(3,195,231)	(5,224,414)	(8,602,118)

¹ State Backfill does not include \$3.62 million in property tax backfill for 2017-18 that is yet to be received

² Other Financing Sources for FY 2018-19 include \$2.73 million in use of General Fund Reserves as well as various other one-time transfers in.

³ Wages and Benefits include \$5.8 million in budgeted salary savings to account for vacancies during the year

⁴ Prior year savings reserved for labor agreements will offset the 2018-19 projected deficit

General Fund 5 year Fiscal Forecast - Assumptions - Attachment A

Draft Sources:	FY 19-20	FY 20-21	FY 21-22	FY 22-23
	Projected	Projected	Projected	Projected
Property Tax	4.00%	3.50%	3.00%	2.50%
Sales Tax	1.70%	1.70%	1.40%	1.40%
TOT	3.00%	2.50%	2.00%	2.00%
Other Tax	0.00%	0.00%	0.00%	0.00%
Licenses and Permits	0.00%	0.00%	0.00%	0.00%
State and Federal*	2.50%	2.50%	2.00%	2.00%
Fines	0.00%	0.00%	0.00%	0.00%
Use of Money/Property	0.25%	0.25%	0.25%	0.25%
Other Charges**	1.63%	1.63%	1.63%	1.63%
Miscellaneous	1.00%	1.00%	1.00%	1.00%
Transfers	1.00%	1.00%	1.00%	1.00%
Other Financing Sources	1.00%	1.00%	1.00%	1.00%

*State Prop 172 Public Safety Funding grows at the Sales Tax percentage

**Other Charges include internal and some external charges, and are projected to increase at 1/2 the rate of salary and benefits

Uses: Salary and Benefits	FY 19-20	FY 20-21	FY 21-22	FY 22-23
	Projected	Projected	Projected	Projected
Salary and Prorated Benefits	2.86%	2.25%	2.25%	2.25%
Pension (non-POB)*	4.92%	4.30%	4.30%	4.30%
POB	Set at scheduled repayment rate			
OPEB	Tracks salary and benefits less reductions			
Medical Insurance	0%	0%	0%	0%

*Pension rates increase with salary and benefit growth compounding with an additional 2% growth to account for discount rate change, other assumption changes, and 0.5% accelerated unfunded liability.

Uses: Non-Salary and Benefits	FY 19-20	FY 20-21	FY 21-22	FY 22-23
	Projected	Projected	Projected	Projected
Services and Supplies	3.00%	3.00%	3.00%	3.00%
Other Charges	2.00%	2.00%	2.00%	2.00%
Fixed Assets	0.00%	0.00%	0.00%	0.00%
Transfers (except below)	1.00%	1.00%	1.00%	1.00%
Pavement	2.00%	2.00%	2.00%	2.00%
IHSS	3.50%	3.50%	3.50%	3.50%
Reimbursements	1.00%	1.00%	1.00%	1.00%

County of Sonoma County Administrator's Operations and Budget Team



FIVE YEAR BUDGET IMPROVEMENT PLAN 2019-2024

November 13th, 2018

FIVE YEAR BUDGET IMPROVEMENT PLAN 2019-2024

A year ago, the County responded to the most destructive wildfires in California history. The County's Recovery Framework in response to those wildfires is driving priorities for the current budget development cycle and throughout the scope of this five-year improvement plan. On June 17th, 2016, the Board adopted a fiscal policy to achieve a structurally balanced budget. The Board directed staff to achieve a structurally balanced budget by FY 2020/21. The wildfires have accelerated the movement toward a structurally balanced budget. The five-year forecast spanning FY 2018/19 – 2022/23 projects a deficit of \$2.9 million starting in FY 2018/19 increasing to \$8.6 million by FY 2022/23 given the trend in revenues over the forecast period still continues to be outpaced by expenditures at approximately 2%.

An economic reset is likely to occur in 2020 as predicted by Vanguard in a recent New York Times article. (Sommer, Jeff. "Vanguard Warns of Worsening Odds for the Economy and Markets" *The New York Times*, 10 August 2018.)

"Vanguard tracks data to predict the likelihood of a recession at certain points in the future. In recent years, the company has put the probability of a recession six months out at close to 10 percent. Now, Vanguard says the chances of one by late 2020 are between 30 and 40 percent. That's Vanguard's highest-ever estimate for that time frame, Mr. Davis said. A six-month forecast reported a greater than 40 percent probability before the recession that started in December 2007."

Due to the wildfire event, the likely economic reset, and the current five year fiscal forecast, it is imperative that the County maintain a focus on fiscal sustainability in order to be more resilient to swings in the economy and other potential events

BUDGET IMPROVEMENT PLAN OVERVIEW

As a part of achieving a structurally balanced budget the County Administrator's Office (CAO) engaged in a budget "debrief and planning process" to improve the County's budget and identify the steps and timeline necessary to make improvements. This Budget Improvement Plan is the culmination of those planning sessions and project team efforts over the last few months. The recommendations contained in the plan were coordinated with the County Administrator and the Auditor Controller Treasurer Tax Collector.

Additionally, to improve communications and provide enhanced customer service, the Operations and Budget team created a new countywide fiscal team of key financial staff from all county departments. To tackle specific issues, project teams were created including relevant financial staff to review administrative policy thresholds, internal services, development of a service inventory process, and General Fund allocation approaches. The fiscal team and related project teams are listed in **Attachment 1**. The countywide fiscal team began meeting monthly in July 2018 and beginning in October 2018 through the FY 2019/20 development cycle will meet twice a month to work through budget and finance issues and assess efficiencies.

Recovery from the Sonoma Complex wildfires has been the County's top priority and has required significant staff resources throughout the organization. A Disaster Finance Team was formed immediately after the fires to help the County navigate

through the complex Federal Emergency Management Agency claim process. To maximize the County's grant opportunities post disaster, a Grants Steering Committee was formed. To date, the Grants Steering Committee has assisted the Office of Recovery and Resiliency in reviewing and assessing grant applications. The Grant Steering Committee will continue in existence in order to support the Office of Recovery and Resiliency's efforts to maximize grant revenues focused on resiliency projects. In June 2018, the Board assigned \$6.5 million out of General Fund Reserves to be used toward recovery efforts including match requirements for recovery and resiliency related grants that may be awarded over the next two years. The majority of grant opportunities listed below will begin to be notified of award as early as the summer of 2019.

To date grants submitted during the tenure of the Grant Steering Committee include:

- 31 recovery grants: \$51 million
- 20 Hazard Mitigation Grant Program (HMGP) grants: \$39.7 million

If the County were awarded all of the above grants, the General Fund match requirement is estimated to be \$5.2 million.

VISION, MISSION, VALUES, AND GOALS

The Operations and Budget team has a long term vision for the County budget that provides a path for implementation of best practices for local government outcome budgeting. The team is pleased to share this Budget Improvement Plan and the steps identified over the next five years to achieve these goals.

VISION

Foster a resilient and sustainable balanced budget model for long-term organization and community health through effective and efficient fiscal principles, process, communication, training, and use of technology.

MISSION

Provide the Board of Supervisors, the public, and fiscal staff with sustainable, resilient countywide fiscal planning and operations.

VALUES

- Sustainability
- Transparency
- Strategic Alignment to Priorities
- Performance-based

GOALS

Goal 1: Foster a balanced budget model that is sustainable for long-term financial planning and is resilient to swings in revenues and expenditures.

Goal 2: Leverage resources through enhanced service delivery integration and stakeholder collaboration.

Goal 3: Inventory county government services and identify alignment with Board priorities.

Goal 4: Harness performance metrics that provide data for decision making.

Goal 5: Present budget documents that are transparent, understandable, inform the public and decision makers, and implement non-profit principles to achieve priority outcomes.

An overview of each goal, including desired outcomes and strategic actions, as well as improvement plan recommendations are described in the following sections.¹

Goal 1: Resilient, Balanced Budget

Foster a balanced budget model that is sustainable for long-term financial planning and is resilient to swings in revenues and expenditures.

Desired Outcomes

Under a balanced budget model, the County's ongoing revenues meet ongoing expenditures. A desired outcome is that the County is able to maintain community services and meet priority needs, while at the same time building General Fund Reserves to meet the Board's policy (reserves should equal two months operating revenues).

¹ To achieve these goals, the Operations and Budget team maintains a detailed 18-month work plan with the County Administrator. The details for each 18-month cycle of the five-year improvement plan, along with the current budget development cycle, are updated annually. The Operations and Budget team also takes the budget development framework to the Board each December.

Strategic Actions and Timeline

FY 18/19

The Operations and Budget team began the fiscal year with a single focus to ensure the resiliency and sustainability of the budget. Several strategic actions were initiated to help the County attain this desired outcome. Internal service providers are leading an inventory of services including identifying their level of mandate. As a part of this effort, staff bench-marked other jurisdictions for rate structures and satisfaction levels to assist the development of an internal services improvement plan.

Another strategic action that contributes to this goal is a renewed multi-year fiscal illustration of all funds to better understand the impacts of service delivery changes as well as revenue and expenditure pressures outside of the General Fund. The CAO is working with the Auditor Controller Treasurer Tax Collector to better assess trends with multiple data sets for more accurate estimates in the allocation of General Fund dollars and other funds' capacities. Utilizing these additional data sets will help establish resiliency for organization capacity into the future.

To maximize the County's capacity for recovery and resiliency in response to the Sonoma Complex Fires, the County Administrator created a Grants Steering Committee to maintain coordination across various parts of the County organization. The structure helps update the Board regarding disaster grants and resiliency grant efforts. The County has subject matter experts that are participating in the Grant Steering Committee who are guiding and reviewing submissions as needed for areas that do not already have the in-house expertise. The Grant Steering Committee fits into a larger structure of resiliency countywide. The Grant Steering Committee's vision is to be an

information sharing hub, where County resources and expertise are leveraged to attract external financial resources that move forward the strategic priorities of the County Board of Supervisors, departments, and districts. There is a resiliency network between the recovery priorities and their department leads, the Office of Recovery and Resiliency, the Operations and Budget Team, and the Disaster Finance team.

FY 19/20

In the budget development cycle for FY 19/20, internal services are aligning policies for equitable application and exploring the creation of an internal rate stabilization fund for General Fund departments to help smooth out impacts from future rate increases. FY 19/20 internal service rates will include updated service descriptions to better communicate what the various rates include. The internal service provider departments are also implementing a customer service model with common pricing principles. The intent is to implement common pricing principles across internal service providers. The best practices guidance, Government Finance Officers Association Best Practice for Pricing Internal Services, is **Attachment 2**. This guide is providing a best practice for improving the internal services framework and its new set of pricing principles.

Specific efficiencies include reduced collection rates for non-public safety fleet vehicles and streamlining facility operations and maintenance.

FY 20/21

The internal services committee will recommend an improvement implementation plan for longer term efficiencies that require in depth analysis spanning the next three

years. These efficiencies include process improvement reviews and analysis of data trends to inform improvements.

FY 21/22 and FY 22/23

The County Administrator, along with the Auditor Controller Treasurer Tax Collector, will develop and implement an incentive principle to invest in efficiencies and improvements identified by departments with one-time discretionary funds from year end balances. These identified innovations will allow the County to invest in programs and services that are tied to the Board's priorities. An example of innovative budgeting that stands out is from the City of Baltimore. According to Andrew Kleine, author of *City on the Line: How Baltimore Transformed Its Budget to Beat the Great Recession and Deliver Outcomes*, the city collects Requests for Results (RFR) for their outcome budgeting process. Baltimore's departments submit funding proposals where each proposal is required to address the following factors:

- Value – efficiency and effectiveness of the service.
- Alignment with priorities.
- Innovation – new solutions or process improvements.
- Are multiple priorities addressed? Preference is given to proposals that do.
- Funding leveraged – ability to leverage other funds, resources, or collaborations for service delivery.
- Evidence-based service delivery outcomes – professional best practices and empirical data to support the proposal.
- Inclusion in a strategic plan?
- Focus on customer service?

The City of Baltimore has changed budgeting from a process of allocating dollars to a process of purchasing results. With examples of success in other jurisdictions it is important to recognize “The budget can be a powerful tool for encouraging and rewarding collaboration.” (Kleine, Andrew, and Peter Hutchinson. *City on the Line: How Baltimore Transformed Its Budget to Beat the Great Recession and Deliver Outcomes*. Rowman & Littlefield, 2019.)

Goal 2: Integrate and Collaborate

Leverage resources through enhanced integration and collaboration.

Desired Outcomes

Achieving this goal requires County departments, agencies, and functions to work collaboratively and become integrated around service delivery. True integration breaks down silos and allows services to be provided efficiently and seamlessly. The organizational benefit of true integration eliminates duplication of efforts and allows for shared resources to create stronger ties to each other and the services provided by the County as a whole.

Strategic Actions and Timeline

FY 18/19

To assist countywide financial operations and build communications across departments, the County Administrator created a countywide fiscal team which meets one to two times monthly to discuss relevant issues, assignments, and partner to help solve complex issues together. This committee formed three subcommittees to help shape the service inventory project, General Fund allocation methodology, and

performance measurement objectives. The countywide fiscal team is a venue for any topic to be vetted by departmental fiscal staff and to help implement changes or respond to issues.

To ensure the county is taking an organized approach to outside funding opportunities, the County Administrator formed the Grants Steering Committee. This committee meets weekly to discuss grant opportunities, coordinate resources, and provide status updates. The outcome so far has been coordinated communication, sharing expertise, and enhanced participation by the county in multiple funding streams.

FY 19/20

To further enhance coordination across departments, the FY 2019/20 budget cycle will include cross-departmental budget workshops with the Board. The workshops will be broken down into the five functional areas: Administration and Finance, Health and Human, Development Services, Justice Services, and Natural Resources.

Attachment 3 includes a list of the departments by functional area. The workshops are intended to provide opportunities to collaborate on service delivery and efficiencies within a department cluster and address fiscal challenges. The Operations and Budget team will be collaborating in with the functional groups so that next year's priorities, challenges, and opportunities are addressed more holistically. The budget workshops are scheduled for April 9th – 10th, 2019.

FY 20/21

As departments discreetly identify services (see Goal 3 below) within functional areas, further opportunities for increased collaboration and efficiencies will be identified.

FY 21/22 and FY 22/23

Implement ongoing functional area collaboration in the fall of each year to plan for the upcoming budget cycle and revisit longer term goals, outcomes, and strategic actions holistically. Continue collaboration across functional areas toward community priorities and integration toward “*One County*” as a high-performance organization providing integrated services.

Goal 3: Service Inventory

Inventory county government services and identify alignment with Board priorities.

Desired Outcomes

The desired outcome of this goal is that County departments and agencies consistently identify services provided both internally and externally along with level of authority granted to the organization for providing those services (mandated/discretionary). The desired outcome is to understand what is being provided, by whom, at what level, and where it is prioritized.

The Operations and Budget team is exploring the Charlotte-Mecklenberg County approach to the service inventory exercise. This exercise lays the foundation for identifying key performance indicators as well as data for determining how well the services are being performed. The example below is a service level choice matrix that Charlotte-Mecklenberg County uses to identify all services provided by the organization. The budget is organized by department and services provided and is color coded to match the service level choice matrix below. A major benefit of this approach is knowing at a glance where the discretionary choices are.

	No Funding Choice	Funding Choice
No Program Choice	No Choices (Programs or Funding) FY2017 Total Dollars: \$436,069,461	No Program Choice Funding Choice FY2017 Total Dollars: \$815,738,008
Program Choice	Program Choice No Funding Choice FY2017 Total Dollars: \$22,522,549	Program Choice Funding Choice FY2017 Total Dollars: \$366,562,403

RED: MANDATED/MANDATED							
Item	FT	PT	Agency	County Dollars	Total Dollars	County % of Total	
CPCC - DEBT	0	0	CPC	8,901,176	9,945,379	90%	
CHILDCARE SERVICES (DSS)	0	0	DSS	791,571	46,358,837	2%	
MEDICAID RELATED PAYMENTS (DSS)	0	0	DSS	3,255,794	3,255,794	100%	
MEDICAID TRANSPORTATION (DSS)	0	0	DSS	25,668	5,100,000	1%	
DEBT SERVICE	0	0	DSV	125,334,799	133,411,288	94%	
CHARLOTTE AREA TRANSIT SYSTEM (FIN)	0	0	FIN	0	48,000,000	0%	
FIRE SERVICE DISTRICT (JCC)	0	0	JCC	0	4,782,633	0%	
LESF (JCC)	0	0	JCC	680,000	16,876,793	4%	
ABC PROFIT DISTRIBUTION	0	0	NDP	332,000	332,000	100%	
REVENUES (NDP)	0	0	NDP	-3,396,000	0		
CMS-DEBT	0	0	SCH	105,095,736	166,903,640	63%	
TRAINING DIVISION - MANDATED (SHF)	7	0	SHF	1,103,097	1,103,097	100%	
TOTAL:	7	0		242,123,841	436,069,461	56%	

Strategic Actions and Timeline

FY 18/19

The countywide fiscal team service inventory subcommittee was formed to assist in identifying the model for the FY 2019/20 service inventory exercise. The County is also engaging in updating the County's Continuity of Operations Plan (COOP) that will

assist in early identification of essential and/or mandated services for all departments and agencies.

FY 19/20

The first round of departments to develop a service inventory will be those in the following two functional areas: 1) Administrative and Fiscal Services Functional Area and 2) Developmental Services Functional Area. The forms for collecting this data will be issued to all departments at the same time allowing any department that already has the data to begin. This exercise will leverage the essential/mandated services identified in the Continuity of Operations Plan update currently underway.

FY 20/21 through FY 22/23

The second round of departments to develop a service inventory will be those departments in the remaining three functional areas: 1) Justice Services, 2) Health and Human Services, and 3) Natural Resources. This exercise will leverage the essential/mandated services identified in the Continuity of Operations Plan update happening for all departments and agencies in November 2019. It is anticipated that by the budget hearings for the FY 2020/21 budget, budgets will be broken out to the service level. The City of Bellevue, WA also uses outcome based budgeting at the service level to help them function as a high performance organization. Please see example below for how Bellevue's budget proposals are submitted for review. Bellevue uses "Budget One" to develop their budget. "Budget One" is a process that identifies the community's priorities called outcomes, prioritizes services to meet those outcomes, and funds those services with the available monies. Budget One encompasses all funds of the city and is a zero-based budget with recommendations prioritized by committee.

The Bellevue service level approach is an examination of the entire budget, not just incremental changes from the last budget with a commitment to innovation, efficiency, and sound business practice that is focused on citywide, not department, priorities. For Bellevue, this budgeting method provides a long-range strategic approach to an

City of Bellevue - Budget One 2017-2018 Operating Budget Proposal Summary

Economic Growth and Competitiveness

130.17NA **Title:** Downtown Parking Enforcement

Ranking **Department:** Transportation

5

	Budget:	<u>2017</u> \$107,290	<u>2018</u> \$109,896
	FTE:	0.00	0.00

This proposal will continue to provide enforcement for on-street parking in the Downtown. Short-term on-street parking in the Downtown creates turnover in parking spaces, thus increasing the overall parking availability for retail customers and general downtown visitors, a goal of the Downtown Subarea Plan. This proposal includes the funding needed to hire a contractor to provide enforcement services. The staffing and administration necessary to support this proposal are provided through the Traffic Engineering and Safety proposal.

<u>Performance Measure</u>	<u>Frequency</u>	<u>2014</u> <u>Actual</u>	<u>2015</u> <u>Actual</u>	<u>2016</u> <u>Target</u>	<u>2017</u> <u>Target</u>	<u>2018</u> <u>Target</u>
# Downtown parking spaces available	Months	310	343	300	300	310
Downtown parking complaints received/responded	Months	109	319	250	250	250

	Total:	<u>2017</u> Budget: \$19,047,632	<u>2018</u> \$20,494,875
		FTE:	61.10 62.10

affordable and sustainable budget and if expenditure reductions are necessary, service elimination is preferable to poor or marginal quality programs.

Goal 4: Performance Budgeting

Harness performance metrics that provide data for decision making.

Desired Outcomes

The desired outcome of this goal includes the identification of key performance metrics that inform the public about how well services are being delivered, what

resources are needed to deliver those services, and inform budget decisions that may affect service levels and delivery. Publishing key performance metrics in the budget help the County assess the effectiveness of service delivery output vs. outcome and identify trends.

Strategic Actions and Timeline

Once the Service Inventory is completed (Goal 3 above), then, performance metrics can be developed. Departments that already track key metrics for state or federal reporting can begin associating these with essential/mandated services. The mandated services exercise will inform decision making for service level priorities. These service level priorities are the framework for identifying key performance metrics for the County.

As the County strives to be more transparent, staff is learning about other jurisdictions that became award winning for best financial and performance management practices and how those jurisdictions transformed their organizations. One county (Charlotte-Mecklenberg County) utilized The Balanced Scorecard Institute to help track resource investments and results:



<https://www.balancedscorecard.org/BSC-Basics/About-the-Balanced-Scorecard>.

This is one method the County could consider when implementing performance measurement. The balanced scorecard data sets provide key performance indicators by program area that inform decision making about customer experience, financial performance, process performance, and organization capacity while tracking initiatives and outcomes against targets. Performance measures will inform future budget policy decisions measuring performance should generally answer the following questions: How much did we do? How well did we do it? Is anyone better off?

Goal 5: Community Engagement

Present budget documents that are transparent, understandable, inform the public and decision makers, and implement non-profit principles to achieve priority outcomes.

Desired Outcomes

The desired outcome of this goal aligns both the organization and community toward common purposes and priorities, better outcomes through enhanced partnership

with non-profit service providers, educate both the County organization and the public about the budget, and provide multiple opportunities for input.

Strategic Actions and Timeline

FY 18/19

In accordance with the County's Recovery and Resiliency Framework, cross departmental staff are working on developing principles and guidelines for performance-based contracting with our non-profit service providers to increase efficiency and effectiveness, particularly with regard to safety net service delivery. This will assist leadership in understanding how much is annually awarded to providers and establish performance expectations to ensure that the County's non-profit partners meet community service needs. The draft principles and guidance will be brought to the Board early next year for the Board's consideration. **Attachment 4** is a report of how much the County has provided to non-profit partners in FY 2017/18.

FY 19/20

To further enhance community engagement, staff will continue to work with the Community and Government Affairs team to produce the budget at a glance and develop a civics class for both the County organization and the public that will include a "*Budget 101*" component.

FY 20/21 through FY 22/23

Staff will work with the Community and Government Affairs team to conduct an employee and a community survey to capture the perspectives of the organization and public to inform budget priorities. Staff will begin delivering the civics class to both the county organization and the community as well as developing and implementing

feedback methods. The example below shows the type of data that can be gathered in a community survey. This example is from the City of Bellevue, WA and highlights community perceptions providing vital information to the organization for budget priorities and initiatives.



https://bellevuewa.gov/UserFiles/Servers/Server_4779004/File/pdf/Finance/2015_Vital_Signs_Bellevue_WEB_03.pdf

To gather priorities in a multitude of way and report out on various initiatives, staff will identify an online tool for interactive communication. As outlined in *Good Governance in the Public Sector* (International Public Sector Governance Framework (International Framework developed jointly by the Chartered Institute of Public Finance and Accountancy (CIPFA) and the International Federation of Accountants (IFAC) 2013) the public input tool must “ ensure that the services provided are contributing to the achievement of intended outcomes...has processes in place to collect and evaluate the views and experiences of people and organizations of all backgrounds...the interests of the more vocal stakeholder groups to be balanced with other stakeholders’ interests to ensure that no one group becomes too dominant...take into account the interests of future generations of tax payers and service users (intergenerational equity)” .

This five year Budget Improvement Plan details how the Operations and Budget team plan to achieve a resilient and sustainable balanced budget model for long-term organization and community health through effective and efficient fiscal principles, process, communication, training, and use of technology. The strategic actions outlined in the plan provide general direction for staff work plans and the various project team timelines. The Operations and Budget team will return to the Board as needed for direction on the implementation of these goals and their related recommendations.

The following staff contributed to the Five Year Budget Improvement Plan 2019-2023:

Sheryl Bratton, County Administrator

Christina Rivera, Assistant County Administrator

OPERATIONS AND BUDGET TEAM

Niki Berrocal, Deputy County Administrator

Peter Bruland, Principal Analyst

Michelle Arellano, Analyst III

Katherine DiPasqua, Analyst III

Nikolas Klein, Analyst III

Terri Wright, Analyst III

Joanna Lutman, Administrative Aide

Diana Wilson, Extra Help Administrative Aide

Special Thanks to Michele Bowman, Administrative Services Officer (backfill for

Michelle Arellano 3/18 - 10/18) and Ric Giardina, Workforce Development Coordinator

<http://sonomacounty.ca.gov/County-Administrators-Office/>

ATTACHMENT 1

County of Sonoma Fiscal Team FY 2018/19

Department	Name	Title	Projects
Agricultural Commissioner	Gina Lehl	Administrative Services Officer	Service Inventory
Agricultural Commissioner	Esther Martinez	Department Analyst	Net Cost Targets
Auditor Controller Treasurer Tax Collector	Julianne Kamplain	Administrative Services Officer II	
Child Support	Alicia Ceniceroz	Administrative Services Officer II	Net Cost Targets, Internal Services Customer Focus
Community Development Commission	Trish Blue	CDC Controller	Service Inventory
County Administrator	Niki Berrocal	Deputy County Administrator	All
County Administrator	Peter Bruland	Principal Analyst	Internal Services, Net Cost, Service Inventory
County Administrator	Michelle Arellano	Analyst III	Internal Services
County Administrator	Katherine DiPasqua	Analyst III	Internal Services
County Administrator	Nikolas Klein	Analyst III	
County Administrator	Terri Wright	Analyst III	
County Counsel	Kelli Logasa	Administrative Services Officer I	Internal Services
District Attorney	Renate Amantite	Administrative Services Officer II	
Economic Development Board	Rebekah Heinze	Department Analyst	
Fire & Emergency Services	Dagny Thomas	Fire & Emergency Services	
General Services	Tamra Pinoris	Administrative Services Officer II	Internal Services
General Services	Danielle Scannell	Supervising Accountant	Internal Services
Health Services	Susan Kelleher	Supervising Accountant	Net Cost Targets, Service Inventory
Health Services	Ryan Harrison	Supervising Accountant	
Health Services	Kelley Naiman	Department Accounting Manager	Net Cost Targets, Service Inventory, Internal Services Customer Focus
Human Resources	Gina Javier	Administrative Services Officer II	Internal Services, Service Inventory
Human Services	Tina Rivera	Department Administrative Services Director	Performance Metrics, Internal Services Customer Focus
Human Services	Roy Dajalos	Administrative Services Officer I	Net Cost Targets, Service Inventory
Information Systems	Shane Lewis	Administrative Services Officer II	Internal Services
Information Systems	Michele Bowman	Administrative Services Officer 1	Internal Services, Service Inventory, Net Cost
Open Space	Mary Dodge	OSA Administrative & Fiscal Services Manager	
Permit and Resource Management	Tamera De Censo	Administrative Services Officer II	
Permit and Resource Management	Regina De La Cruz	Administrative Services Officer II	
Permit and Resource Management	James Walsh	Accountant III	
Probation	Christine Williams	Administrative Services Officer II	Service Inventory, Internal Services Customer Focus
Public Defender	Trisha Griffus	Administrative Services Officer	Service Inventory
Regional Parks	Tasha Houweling	Administrative Officer II	
Sheriff Admin	Heidi Keith	Administrative Services Director	
Sheriff Detention	Connie Newton	Administrative Services Director	Internal Services Customer Focus
Transportation & Public Works	Monique Chapman	Administrative Services Officer II	Internal Services Customer Focus
UC Cooperative Extension	Deborah Curle	Department Analyst	
Water Agency	Lynne Rosselli	Administrative Services Officer II	

ATTACHMENT 1

Disaster Finance Team	
Member	Department
Ryan Burns	Auditor Controller Treasurer Tax Collector
Amanda Thompson	Auditor Controller Treasurer Tax Collector
Vanessa Thomas	Auditor Controller Treasurer Tax Collector
Kanchan Charan	Auditor Controller Treasurer Tax Collector
Damian Gonshorowski	Auditor Controller Treasurer Tax Collector
Olga Gray	Auditor Controller Treasurer Tax Collector
Niki Berrocal	County Administrator
Christina Rivera	County Administrator
Peter Bruland	County Administrator
Misha Bailey	County Administrator
Elizabeth Coleman	County Counsel
Aldo Mercado	County Counsel

ATTACHMENT 1

Grant Steering Committee FY 2018/19	
Member	Department
Kirsten Larsen	Community Development Commission
Niki Berrocal	County Administrator
Misha Bailey	County Administrator
Peter Bruland	County Administrator
Marissa Montenegro	County Administrator
Michael Gossman	County Administrator
Caerleon Safford	Fire and Emergency Services
Keith Lew	General Services
TBD	Health Services
Shane Lewis	Information Systems Department
Robert Butler	Information Systems Department
John Mack	Permit Sonoma
Lisa Hulette	Permit Sonoma
Hattie Brown	Regional Parks
Heidi Keith	Sheriff
Hunter McLaughlin	Transportation and Public Works
Joan Hultberg	Water Agency
Jake Spaulding	Water Agency

ATTACHMENT 1

Internal Services Committee	
Member	Department
Jennifer Calderon	Auditor Controller Treasurer Tax Collector
Levi Ehrlich	Auditor Controller Treasurer Tax Collector
Erick Fladseth	Auditor Controller Treasurer Tax Collector
Katherine DiPasqua	County Administrator
Niki Berrocal	County Administrator
Peter Bruland	County Administrator
Michelle Arellano	County Administrator
Kelli Logasa	County Counsel
Danielle Scannell	General Services
Tamra Pinoris	General Services
Kim Whalen	General Services
Marcia Chadbourne	Human Resources
Gina Javier	Human Resources
Michele Bowman	Information Systems Department
Shane Lewis	Information Systems Department

Internal Services Customer Focus Group	
Member	Department
Alicia Cenicerroz	Department of Child Support Services
Kelly Naiman	Department of Health Services
Tina Rivera	Human Services Department
Chris Williams	Probation
Monique Chapman	Transportation and Public Works
Connie Newton	Sheriff's Office



Government Finance Officers Association

BEST PRACTICE

Pricing Internal Services

BACKGROUND:

Internal services are those responsibilities a government provides to support its own internal operations. Common examples of internal services include information technology, payroll, motor pool, budgeting, legal, accounting, and human resources. Certain management objectives are served by creating a system to assign prices for the use of these internal services, which are then assessed to the departments that use the services. However, there is a cost to develop and maintain internal pricing systems. Governments must weigh the benefits of an internal services costing system against the cost and complexity of system design choices. Please note that this best practice is intended to apply to internal service charges regardless of whether it is accounted for in an internal service fund or as a general fund overhead allocation.

RECOMMENDATION:

GFOA recommends that governments follow these steps when considering an internal service pricing system:

1. Identify goals of internal service pricing;
2. Develop allocation strategy;
3. Define level of costing detail;
4. Determine cost of service;
5. Decide basis of allocation; and
6. Consider potential drawbacks.

Identify goals of internal service pricing. As a first step, GFOA recommends that governments identify the goals they hope to achieve through a pricing system for internal services. The goals will guide the design of the system. Potential goals for a pricing system include:

- *Govern demand for a service.* If the customers of an internal service are not charged based on their level of use they may have an incentive to over-use the service. Alternatively, charges may cause customers to limit their use of the service.
- *Develop enterprise rate models.* Government enterprises (e.g., a water utility) may use services provided by the general government. A pricing system could provide an input into the rate model used to calculate fees for the customers of the enterprise.
- *Calculate indirect cost reimbursement for grants.* Some grants may allow indirect costs to be reimbursed. An internal pricing system provides support for the reimbursement request.
- *Provide input for full-costing model.* A full costing model provides the total cost of a given service, which enables better informed budgeting and planning. The full cost of a program is equal to the direct cost of program plus the indirect costs. Internal service pricing is essential to calculating indirect costs.

- *Promote discussion about the value of the service provided.* Charging customer departments for use of a service will raise questions about the value received from the service and what the best service delivery model is (e.g., centralized, decentralized, outsourced, etc.). A pricing system can facilitate comparisons with alternative methods of service delivery, including outside providers.
- *Examine value of a shared service model.* Shared services are thought to deliver greater efficiency through economies of scale. A solid pricing model is important for determining if a shared service model is delivering on this promise.
- *Promote competition in service delivery.* Internal services could be run much like a private business, including service level agreements with customers and competition from outside providers (e.g., private firms). Accurate internal charges are essential for a level competitive field.¹
- *Ability to customize service levels for different customers.* A detailed rate model makes it easier to provide a higher level of service to a customer that demands it because they can be charged a higher fee.

Develop allocation strategy. After the goals have been identified, the organization must decide which internal services will be priced and allocated to user departments. To make this decision, it may be useful to differentiate between market services and those that have more of a policy or regulatory character.

- *Market services* are those where the user departments play the role of consumer. Examples of market services include IT, fleet, and perhaps facilities.
 - The charges for market services have application to goals like promoting competition in service delivery, governing demand, and/or examining the value of a shared service model. Charging user departments for regulatory/policy services could be necessary for goals like developing a full costing system or calculating indirect cost reimbursement for grants.
- *Policy or regulatory services* are used to establish organization-wide policies or ensure compliance with standards. Users of these services cannot be as easily described as customers, but more accurately as regulated. Examples of policy/regulatory services include budgeting, internal auditors, or a chief executive.

Define level of costing detail. Governments need to determine the level of detail associated with costing services.

- A *low level* of detail might define internal services at the department level (e.g., finance department, IT department). A low level of detail might be sufficient for a costing system with limited goals, such as developing enterprise rate models or obtaining reimbursement for indirect costs under a grant.
- A *high level* of detail would define services at the level of programs or other subunits (e.g., the various subdivisions of finance and IT cited earlier). A high level of detail might be needed for goals like governing the demand for service or promoting discussions about the value of a service.

In summary, a higher level of detail will lead to a more accurate costing system since the activities represented by the internal service categories will be more specified. However, more detail also leads to a more complex internal services pricing system. The government must decide if greater complexity (and its associated costs) will be worth the benefits.

Determine cost of service. With the internal services identified at either a high or low level of detail,

the next step is to determine the cost of the service. The elements of the cost that should be considered include:

- *Direct costs.* Direct costs are the most essential cost element. This includes the services personnel, materials, supplies, and contractors.
- *Interest costs from internal loans.* If the internal service takes loans from other parts of the government then a market interest rate may be applied.²
- *Services used from other support services.* A cost model can be designed such that the cost of the internal service reflects not only its direct costs, but also the indirect cost from other support services that it uses (e.g., an IT service uses payroll). This aspect of costing can be performed at varying levels of complexity methods that fully reflect how each internal service uses the services of other internal providers can become much more complex than those that provide less precise estimates.³

Decide basis of allocation. With cost of the service decided, the bases for allocating costs from the internal service to customers must be decided. Table 1 provides examples of internal services and cost allocation bases. Below are general principles that should be observed when determining bases.

- *Cause-and-effect relationship.* Costs should be allocated based on usage or causal factors relating to costs incurred by service provider. See Table 1 for examples of how cost bases for internal services can be related to the usage of various internal services.
- *Benefit received.* The basis for allocation should bear a relationship to the benefit the customer receives from the service. For example, while miles driven might be a good barometer of the benefit that police patrol receives from its vehicles, hours used might be a better measure for public works.
- *Fairness.* The method of cost allocation that will be used must be seen as fair and legitimate by the users of the costing system. The fee should be charged equitably based on use and other considerations.⁴ Users must understand how the costs are calculated and should have a role in determining how the price system will be structured.⁵
- *Legal constraints.* State laws may place constraints on how charges are developed. For example, if the charge for providing a service exceeds the true cost of the service, it could be construed as a tax under the law. Also, federal regulations on grants may place limits on internal charges against grant programs.⁶

Table 1 Examples of Internal Services Cost Allocation Bases

Internal Service	Allocation Basis
Payroll processing	Number of employees, number of checks
Budgeting	Labor hours, size of budget
Insurance	Number of employees, experience
Legal services	Direct labor hours
Office space / rent	Square feet of space occupied
Procurement services	Number of P.O.s, dollar volumes, direct labor
Vehicle costs	Miles driven, hours used
Information technology	Number of devices, server time, number of calls to help desk, direct labor hours

A government might also consider the accounting mechanism for the internal charge. An internal service fund provides the most detailed accounting, but also entails the most administrative effort. If the goals of the internal charge are modest (e.g., not charging back to federal grants, full cost recovery is not a goal), then it may be easier to simply recognize the charge as a general revenue in the general fund (or some other fund as may be appropriate to the circumstances).

Governments should also regularly review their internal charge rates against actual experience for appropriate adjustments. Governments should also develop guidelines to determine what will happen to excess funds should an internal charge generate cost recovery proceeds in excess of actual costs.

Consider potential drawbacks of internal costing systems. Finally, governments should be aware of the drawbacks of internal costing systems below and should consider mitigating strategies.

- *Diminished trust between providers and customers.* A charge system could create a suspicion among customers about how charges are developed and/or administered, especially if the basis of the charges is not adequately communicated to customers.
- *Subverting processes or not using shared services.* If customers perceive charges to be too high or unfair, they may respond by developing their own service capabilities. This can lead to duplication of resources and wasted effort.
- *Acrimony and debate over the charge system.* Even if users do not subvert the system, a costing system that is viewed negatively by users could generate a great deal of debate and discussion energy that could be better spent on other pursuits.
- *Costs exceed the benefits of the system.* A precise internal costing system can be relatively complex. Complexity entails cost, such as training managers to use cost information. Whether this complexity and cost is worth it should be seriously considered in light of the goals for the system and system design choices.
- *Unmet expectations.* Managers can become frustrated with the system if they do not understand what it can and cannot accomplish. For example, if internal charges cause users to lower their consumption of a service they may see their per unit cost rise as the fixed cost of service is now allocated over a lower volume.

Notes:

¹ However, it should be noted that comparing internal charges to a potential external service providers proposed fee cannot be the basis for a sound outsourcing decision because the external providers proposed cost must be compared to the internal costs the government will avoid (i.e., no longer have to incur) by using the external provider (known as avoidable costs). For example, there may be overhead costs included in an internal charge that will not be eliminated (avoided) by using an external provider.

² If used, the interest rate should be consistent with any governing laws/regulations.

³ For example, single step allocations are the least complex, but is less precise, while reciprocal allocations are more precise, but much more complex. For a complete explanation of these methods please consult. R. Gregory Michel. *Cost Analysis and Activity-Based Costing for Government*. (Chicago, Illinois: GFOA) 2004

⁴ For example, the customer may provide value back to the internal service in some way that justifies a lower charge.

⁵ IT governance systems are on example of a means for giving customer departments input into rate modeling decisions. See GFOAs publication *IT Budgeting and Decision Making* (2009)

⁶ For example, the Federal Office of Management and Budget circular A-87 outlines standards for determining costs which can be charged to Federal grants and reimbursement contracts.

203 N. LaSalle Street - Suite 2700 | Chicago, IL 60601-1210 | Phone: (312) 977-9700 - Fax: (312) 977-4806

LEGEND:
General Fund Contribution \$
Total Expenditures (including
Reimbursements) \$

ATTACHMENT 3

FY 2018/19 Adopted Budget by Functional Area

*Does not include non-Departmental General Programs and Initiatives

Administrative Support & Fiscal Services:

\$53.6M/\$316.0M

Auditor Controller Treasurer Tax Coll. - \$5.8M/\$146.5M

Clerk Recorder Assessor- \$13.1M/\$19.2M

Board of Supervisors/County Administrator - \$8.0M/\$9.7M

County Counsel- \$2.7M/\$6.6M

General Services - \$16.7M/\$25.2M

Human Resources - \$6.4M/\$85.2M

Information Systems - \$900K/\$23.7M

Development Services: \$30.3M/\$347.4M

Permit Sonoma - \$3.7M/\$32.1M

Transportation Public Works - \$15.6M/\$143.1M

Fire Emergency Services- \$2.1M/\$11.9M

Community Development - \$1.3M/\$60.9M

Economic Development - \$6.3M

Capital Projects - \$8.0M/\$93.1M

Health and Human Services:

\$38.7M/\$446.9M

Health - \$12.1M/\$165.9M

Human Services - \$26.6M/\$264.9M

In Home Support – \$1.4M

Child Support - \$14.7M

Justice Services: \$162.1M/\$276.7M

Court Support/GJ - \$8.0M/\$15.3M

District Attorney - \$16.6M/\$27.2M

Probation - \$35.6M/\$60.6M

Public Defender - \$10.9M/\$11.2M

Sheriff - \$90.4M/\$161.8M

IOLERO- \$600K

Natural Resources: \$7.5M/\$288.8M

Ag Commissioner - \$1.9M/\$6.6M

Open Space District - \$51.2M

Regional Parks - \$4.4M/\$25.5M

UC Cooperative Extension - \$1.2M

Water Agency - \$204.3M

FY 2017/18 Non-Profit Vendor Report	
Vendor by Department	FY17-18
6TH STREET PLAYERS	\$ 9,000
Economic Development Board	\$ 9,000
Action Network	\$ 82,736
Department of Health Services	\$ 82,736
ADB ENTERPRISE LLC	\$ 90,785
District Attorney Department	\$ 59,745
Sheriff Department	\$ 31,040
ALLIANCE MEDICAL CENTER	\$ 29,047
Department of Health Services	\$ 29,047
ALTERNATIVE FAMILY SERVICES INC	\$ 305,404
Department of Health Services	\$ 267,404
Human Services Department	\$ 38,000
ALZHEIMER'S ASSOCIATION	\$ 12,119
Human Services Department	\$ 12,119
Avance	\$ 15,086
Department of Health Services	\$ 15,086
BECOMING INDEPENDENT	\$ 39,415
Regional Parks Department	\$ 22,581
Sheriff Department	\$ 7,450
Transportation & Public Works	\$ 9,384
BODEGA BAY AREA CHAMBER OF COMMERCE	\$ 44,547
Economic Development Board	\$ 44,547
BODEGA VOLUNTEER FIRE DEPT	\$ 96,379
Fire and Emergency Services	\$ 96,379
BUCKELEW PROGRAMS	\$ 1,769,903
Department of Health Services	\$ 1,769,903
CALIFORNIA HUMAN DEVELOPMENT CORPORATION	\$ 1,030,712
Community Development Comm.	\$ 17,738
Department of Health Services	\$ 969,191
Human Services Department	\$ 43,783
CALIFORNIA PARENTING INSTITUTE	\$ 1,931,412
Department of Health Services	\$ 496,355
Economic Development Board	\$ 6,750
Human Services Department	\$ 1,408,855
Probation Department	\$ 19,452
Catholic Charities of San Francisco	\$ 142,927
Community Development Comm.	\$ 33,369
Department of Health Services	\$ 109,558
CATHOLIC CHARITIES OF THE DIOCESE OF SR	\$ 2,027,836
Community Development Comm.	\$ 1,031,710
Department of Health Services	\$ 359,511
District Attorney Department	\$ 92,730
Human Services Department	\$ 520,135
Probation Department	\$ 23,750
CINNABAR ARTS CORP	\$ 9,450

FY 2017/18 Non-Profit Vendor Report	
Vendor by Department	FY17-18
Economic Development Board	\$ 9,450
CLOVERDALE CHAMBER OF COMMERCE	\$ 12,604
Economic Development Board	\$ 12,604
CLOVERDALE SENIOR MULTI-PURPOSE CENTER	\$ 31,548
Human Services Department	\$ 31,548
COMMITTEE ON THE SHELTERLESS	\$ 466,159
Community Development Comm.	\$ 369,666
Human Services Department	\$ 96,494
COMMUNITY ACTION PARTNERSHIP OF	\$ 512,028
Community Development Comm.	\$ 84,479
Department of Health Services	\$ 376,582
Human Services Department	\$ 50,967
COMMUNITY BAPTIST CHURCH COLLABORATIVE	\$ 160,301
Department of Health Services	\$ 160,301
COMMUNITY CHILD CARE COUNCIL	\$ 1,021,636
Department of Health Services	\$ 884,367
Human Services Department	\$ 137,269
COMMUNITY SUPPORT NETWORK	\$ 1,840,156
Community Development Comm.	\$ 32,451
Department of Health Services	\$ 1,807,705
CONSERVATION CORPS NORTH BAY INC	\$ 733,571
Human Services Department	\$ 617,772
Open Space Department	\$ 11,766
Sonoma County Water Agency	\$ 104,034
COPPERTOWER FAMILY MEDICAL CENTER	\$ 34,500
Department of Health Services	\$ 34,500
Council on Aging Services for Seniors	\$ 1,534,684
Department of Health Services	\$ 89,318
District Attorney Department	\$ 43,532
Human Services Department	\$ 1,401,835
CSU CHICO RESEARCH FOUNDATION	\$ 11,900
Economic Development Board	\$ 11,900
DRUG ABUSE ALTERNATIVES CENTER	\$ 3,832,255
Department of Health Services	\$ 3,695,693
Human Services Department	\$ 136,562
DRY CREEK RANCHERIA BAND OF POMO INDIANS	\$ 20,000
Sonoma County Water Agency	\$ 20,000
EARLY LEARNING INSTITUTE	\$ 611,140
Department of Health Services	\$ 611,140
Extended Child Care Coalition of Sonoma	\$ 5,180
Human Services Department	\$ 5,180
GEYSERVILLE CHAMBER OF COMMERCE	\$ 8,295
Economic Development Board	\$ 8,295
Girl Scouts of Northern California	\$ 5,000
Agricultural Commissioner Dept	\$ 5,000

FY 2017/18 Non-Profit Vendor Report	
Vendor by Department	FY17-18
GOLD RIDGE RESOURCE CONSERVATION	\$ 268,568
Open Space Department	\$ 85,386
Sonoma County Water Agency	\$ 109,058
Transportation & Public Works	\$ 74,124
GOODWILL INDUSTRIES INC	\$ 2,268,433
Department of Health Services	\$ 997,720
District Attorney Department	\$ 37,500
Human Services Department	\$ 1,233,212
GREENINFO NETWORK	\$ 60,819
Open Space Department	\$ 60,819
Healdsburg Center for the Arts	\$ 6,500
Economic Development Board	\$ 6,500
HEALDSBURG CHAMBER OF COMMERCE	\$ 10,000
Economic Development Board	\$ 10,000
INDIVIDUALS NOW INC	\$ 1,575,442
Community Development Comm.	\$ 90,192
Department of Health Services	\$ 689,468
Human Services Department	\$ 795,782
INTERFAITH SHELTER NETWORK INC	\$ 955,897
Human Services Department	\$ 591,863
Probation Department	\$ 364,034
JEWISH FAMILY & CHILDRENS SVCS	\$ 43,074
Department of Health Services	\$ 21,649
Human Services Department	\$ 21,425
KAISER PERMANENTE	\$ 95,478
Fire and Emergency Services	\$ 8,124
Human Resources Department	\$ 87,354
LAGUNA DE SANTA ROSA FOUNDATION	\$ 345,866
Open Space Department	\$ 51,684
Sonoma County Water Agency	\$ 45,259
Transportation & Public Works	\$ 248,924
LANDPATHS	\$ 240,193
Open Space Department	\$ 230,167
Sonoma County Water Agency	\$ 10,026
Latino Service Providers	\$ 154,551
Department of Health Services	\$ 154,551
LAW ENFORCEMENT CHAPLAINCY SERVICE	\$ 32,500
Sheriff Department	\$ 32,500
LEAGUE OF WOMEN VOTERS INC	\$ 5,500
Clerk Recorder Assessor Dept	\$ 5,500
Legal Aid of Sonoma County	\$ 620,552
Community Development Comm.	\$ 195,843
Department of Health Services	\$ 21,291
District Attorney Department	\$ 46,625
Human Services Department	\$ 356,794

FY 2017/18 Non-Profit Vendor Report	
Vendor by Department	FY17-18
Life Technologies Corporation	\$ 29,816
Department of Health Services	\$ 29,816
LifeWorks of Sonoma County	\$ 138,331
Department of Health Services	\$ 129,352
Human Services Department	\$ 8,979
Lilliput Children's Services	\$ 386,993
Human Services Department	\$ 386,993
LOMI SCHOOL FOUNDATION	\$ 282,201
Department of Health Services	\$ 274,416
Human Services Department	\$ 7,785
Luther Burbank Memorial Foundation	\$ 21,200
Economic Development Board	\$ 21,200
MUSEUMS OF SONOMA COUNTY	\$ 15,000
Economic Development Board	\$ 15,000
NAMI SONOMA COUNTY	\$ 293,648
Department of Health Services	\$ 293,648
NATIONAL FIRE PROTECTION ASSOC	\$ 17,995
Sonoma County Water Agency	\$ 17,995
NORTH COAST OPPORTUNITIES	\$ 203,512
Human Services Department	\$ 203,512
NORTHERN CA CENTER FOR WELL BEING	\$ 202,042
Department of Health Services	\$ 196,055
Human Services Department	\$ 5,987
NURSE-FAMILY PARTNERSHIP	\$ 31,789
Department of Health Services	\$ 31,789
Occidental Arts & Ecology Center	\$ 17,774
Department of Health Services	\$ 17,774
ON THE MOVE	\$ 641,585
Community Development Comm.	\$ 14,185
Department of Health Services	\$ 227,887
Human Services Department	\$ 399,512
PERFORMING ARTISTS COALITION FOR THEATER	\$ 8,500
Economic Development Board	\$ 8,500
Petaluma Arts Council	\$ 6,500
Economic Development Board	\$ 6,500
PETALUMA HEALTH CENTER	\$ 135,572
Department of Health Services	\$ 77,172
Human Services Department	\$ 58,400
PETALUMA PEOPLE SERVICES	\$ 1,258,448
Community Development Comm.	\$ 95,416
Department of Health Services	\$ 536,480
Human Services Department	\$ 470,277
Probation Department	\$ 156,276
PETALUMA VISITORS CTR/PETALUMA HOLIDAYS	\$ 12,242
Economic Development Board	\$ 12,242

FY 2017/18 Non-Profit Vendor Report	
Vendor by Department	FY17-18
POSITIVE IMAGES	\$ 107,616
Department of Health Services	\$ 107,616
PUBLIC HEALTH INSTITUTE	\$ 34,975
Department of Health Services	\$ 34,950
REDWOOD COAST CHAMBER OF COMMERCE	\$ 6,800
Economic Development Board	\$ 6,800
REDWOOD COMMUNITY HEALTH COALITION	\$ 304,829
Department of Health Services	\$ 244,744
Sheriff Department	\$ 60,085
REDWOOD EMPIRE FOOD BANK	\$ 115,589
Community Development Comm.	\$ 15,589
Human Services Department	\$ 100,000
REDWOOD EMPIRE FOSTER	\$ 24,000
Human Services Department	\$ 24,000
REDWOOD PSYCHOLOGY CENTER INC	\$ 38,321
Department of Health Services	\$ 38,321
Regents of the University of California	\$ 705,125
Department of Health Services	\$ 6,090
Human Services Department	\$ 280,864
Sheriff Department	\$ 5,455
Sonoma County Water Agency	\$ 412,716
RESTORATIVE RESOURCES	\$ 154,894
Ind Office Law Enf Rvw/Outrch	\$ 58,428
Probation Department	\$ 96,467
River to Coast Children's Services	\$ 35,088
Department of Health Services	\$ 35,088
ROSELAND SCHOOL DISTRICT	\$ 46,333
Department of Health Services	\$ 46,333
RUSSIAN RIVER CHAMBER OF COMMERCE	\$ 120,424
Economic Development Board	\$ 82,776
General Services Department	\$ 37,648
Russian Riverkeeper	\$ 54,213
Community Development Comm.	\$ 11,326
Transportation & Public Works	\$ 42,887
Samuels & Associates	\$ 20,842
Department of Health Services	\$ 20,842
San Antonio Volunteer Fire Department	\$ 149,050
Fire and Emergency Services	\$ 149,050
SAN FRANCISCO ESTUARY INSTITUTE	\$ 90,555
PRMD Department	\$ 29,950
Sonoma County Water Agency	\$ 60,605
SANTA ROSA CHAMBER OF COMMERCE	\$ 94,047
Department of Health Services	\$ 62,547
Economic Development Board	\$ 31,500
Santa Rosa Community Health Centers	\$ 818,916

FY 2017/18 Non-Profit Vendor Report	
Vendor by Department	FY17-18
Department of Health Services	\$ 818,916
SANTA ROSA MEMORIAL HOSPITAL	\$ 24,327
Department of Health Services	\$ 24,327
SANTA ROSA SYMPHONY	\$ 11,000
Economic Development Board	\$ 11,000
SEARCH INSIDE YOURSELF LEADERSHIP INST	\$ 38,500
County Counsel Department	\$ 9,500
Human Resources Department	\$ 24,000
Open Space Department	\$ 5,000
SEBASTOPOL AREA SENIOR CENTER	\$ 78,356
Human Services Department	\$ 78,356
SEBASTOPOL CENTER FOR THE ARTS	\$ 6,300
Economic Development Board	\$ 6,300
SEBASTOPOL CHAMBER OF COMMERCE	\$ 15,921
Economic Development Board	\$ 15,921
SENECA FAMILY OF AGENCIES	\$ 4,391,766
Department of Health Services	\$ 1,049,979
Human Services Department	\$ 2,398,525
Probation Department	\$ 943,262
SENIOR ADVOCACY SERVICES	\$ 732,975
Human Services Department	\$ 732,975
SHANNON ARMITAGE	\$ 13,625
Sheriff Department	\$ 13,625
SONOMA CONSERVATORY OF DANCE	\$ 11,500
Economic Development Board	\$ 11,500
SONOMA COUNTY FAIR & EXPO INC	\$ 193,391
Department of Health Services	\$ 7,123
General Services Department	\$ 121,776
Human Resources Department	\$ 44,492
Sonoma County Water Agency	\$ 20,000
SONOMA COUNTY INDIAN HEALTH PROJECT INC	\$ 100,075
Department of Health Services	\$ 100,075
SONOMA COUNTY OFFICE OF EDUCATION	\$ 483,436
Department of Health Services	\$ 317,109
Human Services Department	\$ 26,999
Probation Department	\$ 20,428
Sheriff Department	\$ 118,900
Sonoma County Tourism	\$ 3,117,576
Economic Development Board	\$ 3,117,576
SONOMA ECOLOGY CENTER	\$ 354,310
Open Space Department	\$ 119,478
PRMD Department	\$ 129,817
Sonoma County Water Agency	\$ 92,229
Transportation & Public Works	\$ 12,786
SONOMA LAND TRUST	\$ 28,028

FY 2017/18 Non-Profit Vendor Report	
Vendor by Department	FY17-18
Sonoma County Water Agency	\$ 22,768
Transportation & Public Works	\$ 5,260
SONOMA VALLEY CHAMBER OF COMMERCE	\$ 10,897
Economic Development Board	\$ 10,897
Sonoma Valley Community Health Center	\$ 39,770
Department of Health Services	\$ 39,720
SONOMA VALLEY VISITORS BUREAU	\$ 94,000
Economic Development Board	\$ 94,000
South Coast Seniors Inc	\$ 13,457
Human Services Department	\$ 13,457
START SOCO	\$ 8,000
Economic Development Board	\$ 8,000
STEARNS CONRAD & SCHMIDT CONSULTING	\$ 86,402
Transportation & Public Works	\$ 86,402
STEWARDS OF THE COAST AND REDWOODS	\$ 5,609
Sonoma County Water Agency	\$ 5,609
SUNNY HILLS SERVICES	\$ 1,161,692
Department of Health Services	\$ 1,161,692
SUPPORT OUR STUDENTS	\$ 413,101
Department of Health Services	\$ 365,735
Human Services Department	\$ 18,609
Sheriff Department	\$ 28,756
THE CENTER FOR SOCIAL AND	\$ 435,802
Human Services Department	\$ 131,521
Probation Department	\$ 291,248
Sonoma County Water Agency	\$ 5,638
Transportation & Public Works	\$ 7,395
THE IMAGINE BUS PROJECT	\$ 18,654
Economic Development Board	\$ 7,500
Probation Department	\$ 11,154
THE MOSAIC PROJECT	\$ 6,000
Human Services Department	\$ 6,000
TLC CHILD & FAMILY SERVICES	\$ 721,440
Department of Health Services	\$ 119,182
Human Services Department	\$ 602,258
TMC DEVELOPMENT WORKING SOLUTIONS	\$ 8,168
Economic Development Board	\$ 8,168
TSUNAMI ENTERPRISES	\$ 5,134
Department of Health Services	\$ 5,134
UNITED WAY OF THE WINE COUNTRY	\$ 271,100
Department of Health Services	\$ 5,250
Human Services Department	\$ 265,850
Community Development Comm.	\$ 8,760
District Attorney Department	\$ 75,374
Human Services Department	\$ 93,784

FY 2017/18 Non-Profit Vendor Report	
Vendor by Department	FY17-18
Probation Department	\$ 20,260
VICTOR TREATMENT CENTERS INC	\$ 331,545
Department of Health Services	\$ 331,545
VINTAGE HOUSE	\$ 40,954
Human Services Department	\$ 40,954
Human Services Department	\$ 209,808
Probation Department	\$ 154,187
Transportation & Public Works	\$ 1,828,950
WATERWORKS INDUSTRIES INC.	\$ 36,055
Regional Parks Department	\$ 36,055
WEST COUNTY COMMUNITY SERVICES	\$ 859,151
Community Development Comm.	\$ 294,580
Department of Health Services	\$ 337,493
Human Services Department	\$ 227,078
WEST COUNTY HEALTH CENTERS	\$ 79,624
Community Development Comm.	\$ 6,167
Department of Health Services	\$ 73,457
WestEd	\$ 58,985
Probation Department	\$ 58,985
WILLOW GLEN CARE CENTER	\$ 306,180
Department of Health Services	\$ 306,180
Wilmar Volunteer Fire Dept	\$ 254,197
Fire and Emergency Services	\$ 254,197
Windsor Chamber Of Commerce	\$ 9,039
Economic Development Board	\$ 9,039
WOMENS RECOVERY SERVICES	\$ 387,797
Department of Health Services	\$ 376,926
Human Services Department	\$ 10,871
YWCA OF SONOMA COUNTY INC	\$ 291,262
Community Development Comm.	\$ 38,295
Department of Health Services	\$ 30,000
District Attorney Department	\$ 147,164
Human Services Department	\$ 75,803
Grand Total	\$ 47,340,950

NOTES:

1. Many of the contracts are supporting Health and Human Services mandates.
2. The data was collected through manual efforts by identifying non-profit vendors through purchasing.
3. This query represents payments made against contract encumbrances, not the entire contract amount.
4. This data set excludes payments under \$5,000.



County of Sonoma Agenda Item Summary Report

Agenda Item Number: 57
(This Section for use by Clerk of the Board Only.)

Clerk of the Board
575 Administration Drive
Santa Rosa, CA 95403

To: Board of Supervisors

Board Agenda Date: November 13, 2018

Vote Requirement: Majority

Department or Agency Name(s): County Administrator's Office

Staff Name and Phone Number:

Sheryl Bratton (707) 565-2431

Supervisorial District(s):

All

Title: Transient Occupancy Tax Program Options

Recommended Actions:

- a. Accept an update on options for the Transient Occupancy Tax program.
- b. Provide direction to staff.

Executive Summary:

The Transient Occupancy Tax (TOT) is levied at a rate of 12% in unincorporated Sonoma County. In 2016, voters approved Measure L, which authorized a 3% increase to the tax – from 9% to 12%.

On October 3rd, 2017, the Sonoma County Board of Supervisors (Board) adopted a policy to direct one-third of the first 9% of revenues received to the General Fund. The remaining two-thirds of the first 9%, and the 3% Measure L portion, were allocated according to the Community Investment Fund Policy for Fiscal Year (FY) 2018-19 budget. The Community Investment Fund Policy (Attachment E) includes a program to allocate Community Non-Profit Grants.

On June 5th, 2018, the Board approved the FY 2018-19 Community Non-Profit Grants Awards. At this time, staff was directed to return with alternative program options for the Board to consider a new range of approaches and strategies.

Discussion:

Program Options

Following is an overview of the current program compared to several new program funding allocation options for the Board's consideration. Attachment A shows the current program as included in the FY 2018-19 adopted budget, while the program options are displayed using a rough projection of FY 2019-20 revenue, to provide a more accurate representation of the options. The FY 2019-20 projection was derived in the following manner:

- TOT is projected to stay flat from FY 2017-18 to FY 2018-19. In FY 2017-18 the Auditor Treasurer Tax collected \$22,237,151, including Measure L.
- The FY 2019-20 projection assumes a 3% growth based on the updated FY2018-19 projection of \$22,237,151. This is a rough estimate and will be revised later this year when more information is available.

Current Program

Summary

- Two-thirds of the base 9% tax rate is dedicated to the Economic Development Board, Sonoma County Tourism, County Departments, Community Non-Profit Grants (see below for categories breakdown), and other County priorities.
- One-third of the base 9% tax rate is allocated to the General Fund.
- The remaining 3% Measure L tax rate is divided according to the Community Investment Fund Policy, which dedicates 20% to Roads, 20% to Parks, 20% to Fire Services, 13% to Affordable Housing, 8% to Enforcement and Compliance, 9% to Event Facilities such as Veterans Buildings, and 10% to Tourism Mitigation.
- Additionally, over the last 5 fiscal years, on average about \$1.8 million has been relied upon from accumulated fund balance to finance the program annually. Fund balance mainly result from actual collections exceeding projected revenues.

Budget Process

- The Community Investment Fund Committee, comprised of two Board members, works with staff to bring recommendations on grant awards for the full Board to approve. This occurs before the County of Sonoma Budget Hearings.

Grant Allocations

The full list of grants awarded over the last three fiscal years can be found in Attachment B. The FY 2018-19 Community Non-Profit Grant categories and funding levels are:

- *Chambers of Commerce Grants*: Allocates \$40,000 to entities for a 10% match award for membership dues that the Chambers collect.
- *Visitors Center Grants*: Allocates \$347,400 to fund visitor centers.
- *Visitor Way Finding & Signage Grants*: Allocates \$100,000 to install permanent signage related to visitor way finding and area identification.
- *Workforce Development and Scholarship Grants*: This category focuses on workforce development and allocates \$500,000.
- *Agricultural Promotion Grants*: Allocates a total of \$160,000 to support advertising campaigns and promotional activities to support agricultural and viticulture industries.
- *Historical Commissions*: Allocates \$60,000 to support historical preservation of the county's culture and historical records and architecture.
- *Major County Events*: Allocates \$300,000 to promote major events and cultural and artistic organizations which draw countywide, regional, state, and national interest.
- *Seasonal and Off Peak Grants*: Allocates a total of \$50,000 to promote seasonal programs, events, as well as events that occur during the off peak tourism season.

- *District Priorities*: Allocates \$250,000 between the five supervisorial districts to assist small cultural, artistic, and countywide events and organizations.

Option A – Current Funding, Modified Procedure

Summary

- All grant categories remain the same.
- Move funding for Departments (excluding Measure L), into the General Fund. These Departments would include the amount they typically receive from TOT in their General Fund request.
- The existing allocations to the General Fund, and the Measure L split, remain unchanged.

Budget Process

- The Board composed Community Investment Fund Committee will be dissolved.
- Staff would rank Community Non-Profit grant applications, and bring all applications to the full Board for consideration during Budget Hearings.

Option B – Eliminate some grants & incorporate Visitor Centers and Chambers of Commerce into the Sonoma County Tourism agreement

Summary

- Maintain the Workforce Development grant category.
- Increase District Priorities from \$250,000 total (\$50,000 per District) to \$500,000 (\$100,000 per District).
 - While not many Counties have grant programs directly from their Transient Occupancy Tax, it is not unusual for Supervisors to have funds allocated to meet district priorities. For instance, San Francisco Supervisors received \$1M each for the next two fiscal years, and in FY 2018-19 San Diego Supervisors each received approximately \$1.2M to meet needs in their respective districts.
 - If Sonoma County Supervisors direct staff to implement a Program Option that increases District Priority Funds, staff recommends that these funds roll-over from year to year, allowing Supervisors to fund more substantial projects. The existing process of bringing all expenditures to the Board of Supervisors for approval would continue.
- Direct staff to include funding Visitor Centers and Chambers of Commerce (total of \$387,400) in the Sonoma County Tourism contract starting in FY 2019-20, as a part of their existing allocation. See the 'Sonoma County Tourism' section below to see how this would affect Tourism funding.
- Eliminate all other grants.
- Move funding for County Departments (excluding Measure L), into the General Fund. These Departments would include the amount they typically receive from TOT in their General Fund request.
- The existing allocations to the General Fund, and the Measure L split, remain unchanged.

Budget Process

- The process for awarding District Priorities remains unchanged.
- The Board member composed Community Investment Fund Committee will be dissolved.
- Staff would rank Workforce Development applications, and bring all applications to the full Board for consideration during Budget Hearings.

Option C – Increase District Priorities, incorporate Visitor Centers and Chambers of Commerce into the Sonoma County Tourism agreement, and General Fund priorities

Summary

- Increase District Priorities from \$250,000 total (\$50,000 per District) to \$500,000 (\$100,000 per District).
- Direct staff to include funding Visitor Centers and Chambers of Commerce (total of \$387,400) in the Sonoma County Tourism contract starting in FY 2019-20, as a part of their existing allocation. See the ‘Sonoma County Tourism’ section below to see how this would affect Tourism funding.
- Eliminate remaining Community Non-Profit grants.
- Move the remainder of funds to General Fund priorities.
- Move funding for Departments (excluding Measure L), into the General Fund. These Departments would include the amount they typically receive from TOT in their General Fund request.
- The existing allocations to the General Fund, and the Measure L split, remain unchanged.

Budget Process

- The process for awarding District Priorities remains unchanged.
- The Board composed Community Investment Fund Committee will be dissolved.

Option D – District Priorities, incorporate Visitors Centers and Chambers of Commerce into the Sonoma County Tourism agreement

Summary

- Increase District Priorities from \$250,000 total (\$50,000 per District) to \$1,500,000 (\$300,000 per District).
- Direct staff to include funding Visitor Centers and Chambers of Commerce (total of \$387,400) in the Sonoma County Tourism contract starting in FY 2019-20, as a part of their existing allocation. See the ‘Sonoma County Tourism’ section below to see how this would affect Tourism funding.
- Eliminate remaining Community Non-Profit grants.
- Move the remainder to General Fund priorities.
- Move funding for Departments (excluding Measure L), into the General Fund. These Departments would include the amount they typically receive from TOT in their General Fund request.
- The existing allocations to the General Fund, and the Measure L split, remain unchanged.

Budget Process

- The process for awarding District Priorities remains unchanged.
- The Community Investment Fund Committee will be dissolved.

Sonoma County Tourism

Contract Timing and Amount

On October 3rd, 2017, the Board approved recommendations of the Measure L Ad Hoc Committee, which included recommendations on setting the Sonoma County Tourism TOT allocation, and a two-year contract for Sonoma County Tourism. Sonoma County Tourism is currently in the second year of the

two-year contract with the Economic Development Board. Starting in early 2019, staff will negotiate a new contract with Sonoma County Tourism, for approval by the Board.

Based on recommendations made to the Board by the Measure L Ad Hoc, in FY 2017-18 the County supplied \$3,117,576 to Sonoma County Tourism to execute their Annual Plan. In FY 2018-19 the County is allocating 1.25 percentage points of the first 9 percentage points of TOT collected within unincorporated Sonoma County to Sonoma County Tourism (the Adopted Budget projects this to be \$2,107,840).

The Measure L Ad Hoc developed this recommendation after reviewing staffing levels and the amount of funds received by the Tourism Bureau from 2008-2016 from both the Business Improvement Assessment (more information below) and from TOT. The Measure L Ad Hoc also reviewed funding and staffing levels of tourism bureaus in comparable California counties.

Business Improvement Assessment

On November 2, 2004, the Board adopted the ordinance creating the Sonoma County Tourism Business Improvement Area (Business Improvement Area) in various cities and in the unincorporated areas of the county. Under the ordinance, lodging establishments generating annual revenue of \$350,000 or more must pay an assessment equal to 2% of such revenue. All Business Improvement Area revenues received by the County are passed on to Sonoma County Tourism, less reimbursements and fees authorized by the Ordinance. In FY 2017-18 the Auditor Controller Treasurer Tax Collector collected \$5,276,779 on behalf of Business Improvement Area.

Potential Impacts to Sonoma County Tourism with Program Options

If the Board continues to allocate Sonoma County Tourism funding using the existing formula recommended by the Measure L Ad Hoc, based on the rough projections for FY 2019-20, their allocation of TOT could increase by \$278,021, to \$2,385,861.

There are currently two clauses in the Sonoma County Tourism contract which may be adjusted in future contracts. These two clauses include: 1) Sonoma County Tourism will expend \$100,000 over two years to secure state-wide or regional conferences, and 2) Sonoma County Tourism will expend a minimum of \$250,000 in FY 2017-18, and a minimum of \$100,000 in FY 2018-19 on tourism enhancement projects. Sonoma County Tourism expended the \$250,000 for FY 2017-18 on community grants, which can be viewed in Attachment G.

If the Board maintained the 1.25 percentage points of the first 9 percentage points of TOT for Sonoma County Tourism, and eliminated the two clauses outlined above, Sonoma County Tourism would have \$428,021 of un-budgeted revenue in FY 2019-20. This could be used to absorb the \$387,400 of Visitor Centers and Chambers of Commerce grants, as discussed in options B, C, and D above.

Audit Status

Sonoma County Tourism is required in their contract to complete three audits:

1. Section 2.2.1: Travel and Meal Reimbursements
2. Exhibit A 3.c: Financial Audit, receipt and/or expenditure of all funds received from County
3. Schedule 3.b: Independent Audit

All three audits will cover from January 1, 2016 - June 30 2017, and from July 1, 2017 - June 30, 2018.

The Auditor Controller Treasurer Tax Collector supplied four reputable auditors to Sonoma County Tourism for the Independent Audit (Maze & Associates; Vavernick Trine & Day; Moss Adams; and Pisenti & Brinker), and Sonoma County Tourism elected to use auditors from the list for all three audits.

Time period: January 1, 2016 - June 30, 2017

- *Section 2.2.1 Travel and Meal Reimbursements*

An auditor from the Auditor Controller Treasurer Tax Collector's list of recommendations will conduct this audit. The scope will be discussed with the Auditor Controller Treasurer Tax Collector, County Counsel, and the County Administrator's Office.

- *Exhibit A 3.c Financial Audit*

Dillwood Burkel and Millar completed the financial audit for this time period.

- *Schedule 3.b. Independent Audit*

Sonoma County Tourism is coordinating a meeting with an auditor from the Auditor Controller Treasurer Tax Collector's list, the County Administrator's Office, and the Auditor Controller Treasurer Tax Collector to establish the scope of this audit.

Time period: July 1, 2017 - June 30, 2018

- *Section 2.2.1 Travel and Meal Reimbursements*

Pisenti and Brinker are conducting the Travel and Meal Reimbursements audit. Sonoma County Tourism shared the proposed scope of work with the County for feedback. The Auditor Treasurer Tax Collector, County Counsel, and the County Administrator's Office reviewed and provided feedback on the scope of work. Pisenti & Brinker completed the fieldwork for the audit, and is currently drafting the audit report.

- *Exhibit A 3.c Financial Audit*

Pisenti and Brinker are conducting the Financial audit. Pisenti & Brinker completed the fieldwork for the audit, and are currently drafting the audit report.

- *Schedule 3.b. Independent Audit*

Sonoma County Tourism is coordinating a meeting with Maze and Associates, the County Administrator's Office, and the Auditor Controller Treasurer Tax Collector to establish the scope of this audit.

Contingencies for Sponsorships and Fee Waivers

Attachment C displays the use of contingencies for Fee Waivers and Sponsorships for Fiscal Years 2014-15, 2015-16, 2016-17, and 2017-18. The total use of contingencies for Sponsorships during this time was \$74,618, and the Fee Waivers totaled \$111,637. Staff will work to provide additional information to the Board for future direction.

Recommended Action

Given that Community Non-Profit Grant applications are normally opened in January of each year, staff is seeking direction on which program option the Board wishes to implement in FY 2019-20. Once direction is given, staff will return to the Board to implement the program direction.

Prior Board Actions:			
6-5-2018: Community Investment Fund Program Awards and Policy Update 10-03-2017: Measure L Ad Hoc Recommendations			
Strategic Plan Alignment		Goal 2: Economic and Environmental Stewardship	
Fiscal Summary			
Expenditures	FY 18-19 Adopted	FY 19-20 Projected	FY 20-21 Projected
Budgeted Expenses			
Additional Appropriation Requested			
Total Expenditures			
Funding Sources			
General Fund/WA GF			
State/Federal			
Fees/Other			
Use of Fund Balance			
Contingencies			
Total Sources			
Narrative Explanation of Fiscal Impacts:			
The item seeks staff direction. Fiscal impacts/changes will be reflected in the FY 2019-20 recommended budget.			
Staffing Impacts			
Position Title (Payroll Classification)	Monthly Salary Range (A – I Step)	Additions (Number)	Deletions (Number)
Narrative Explanation of Staffing Impacts (If Required):			
Attachments:			
Attachment A: Options Matrix			

Attachment B: Three Fiscal Years' Grant Applications

Attachment C: Contingency Reports

Attachment D: Measure L Policy Recommendations

Attachment E: Community Investment Fund Policy

Attachment F: Sonoma County Tourism - Local Tourism Enhancement Grants

Related Items "On File" with the Clerk of the Board:

Transient Occupancy Tax Program Options

	Current Program	Option A Current Funding, Modified Procedure	Option B Eliminate Some Grants	Option C District Grants and General Fund Priorities	Option D District Grants
Program Summary	<ul style="list-style-type: none"> No program changes General Fund Allocation: 1/3 of first 9% 	<ul style="list-style-type: none"> No changes to the allocation of funds Move Internal Funding to General Fund to support the Departments listed below 	<ul style="list-style-type: none"> Increase District Priorities to \$100k per District Maintain Workforce Development, eliminate other Grants Sonoma County Tourism funds Visitors Centers and Chambers from their existing allocation Remainder to General Fund priorities Move Internal Funds to General Fund to support the Departments listed below 	<ul style="list-style-type: none"> Increase District Priorities to \$100k per District Eliminate other grants Sonoma County Tourism funds Visitors Centers and Chambers from their existing allocation Remainder to General Fund priorities Move Internal Funds to General Fund to support the Departments listed below 	<ul style="list-style-type: none"> Increase District Priorities to \$300k per District Eliminate non-District grants Sonoma County Tourism funds Visitors Centers and Chambers from their existing allocation Remainder to General Fund priorities Move Internal Funds to General Fund to support the Departments listed below
Budget Process	<ul style="list-style-type: none"> Community Investment Fund Board Committee Approved before Budget Hearings 	<ul style="list-style-type: none"> Staff ranks applications Applications reviewed by the full Board Board allocates funds at the end of Budget Hearings 	<ul style="list-style-type: none"> Staff ranks applications Applications reviewed by the full Board Board allocates funds at the end of Budget Hearings 	<ul style="list-style-type: none"> District Grants may be awarded throughout the year 	<ul style="list-style-type: none"> District Grants may be awarded throughout the year

Funding	FY 18-19 Amount	% of Allocated TOT	FY 19-20 Amount	% of Projected TOT	FY 19-20 Amount	% of Projected TOT	FY 19-20 Amount	% of Projected TOT	FY 19-20 Amount	% of Projected TOT
---------	-----------------	--------------------	-----------------	--------------------	-----------------	--------------------	-----------------	--------------------	-----------------	--------------------

TOT External Funding Total	4,865,240	23%	5,143,261	22%	4,285,861	19%	3,785,861	17%	4,785,861	21%
District Grants/Priorities	250,000	1%	250,000	1%	500,000	2%	500,000	2%	1,500,000	7%
Workforce Development	500,000	2%	500,000	2%	500,000	2%	-	-	-	-
Major County Events & Org	300,000	1%	300,000	1%	-	-	-	-	-	-
Chambers of Commerce	40,000	0.2%	40,000	0.2%	-	-	-	-	-	-
Visitor Centers	347,400	2%	347,400	2%	-	-	-	-	-	-
Signage	100,000	0.5%	100,000	0%	-	-	-	-	-	-
Agricultural Promotion	160,000	1%	160,000	1%	-	-	-	-	-	-
Seasonal and Off Peak Programs	50,000	0.2%	50,000	0.2%	-	-	-	-	-	-
Historical Commissions	60,000	0.3%	60,000	0.3%	-	-	-	-	-	-
Contingencies for Grants	50,000	0.2%	50,000	0.2%	-	-	-	-	-	-
Sonoma County Tourism	2,107,840	10%	2,385,861	10%	2,385,861	10%	2,385,861	10%	2,385,861	10%
Fire Services	900,000	4%	900,000	4%	900,000	4%	900,000	4%	900,000	4%

TOT Internal Funding Total	6,645,410	31%	6,373,449	28%	7,166,272	31%	7,666,272	33%	6,666,272	29%
General Fund Priorities	-	-	-	-	792,823	3%	1,292,823	6%	292,823	1%
Office of Recovery and Resiliency	271,961	1%	-	-	-	-	-	-	-	-
Regional Parks	2,651,507	12%	2,651,507	12%	2,651,507	12%	2,651,507	12%	2,651,507	12%
ACTTC Collection	407,819	2%	407,819	2%	407,819	2%	407,819	2%	407,819	2%
ACTTC Audit	114,100	1%	114,100	0.5%	114,100	0.5%	114,100	0.5%	114,100	0.50%
Legal Services	41,810	0.2%	41,810	0.2%	41,810	0.2%	41,810	0.2%	41,810	0.18%
Economic Development Board	3,158,213	15%	3,158,213	14%	3,158,213	14%	3,158,213	14%	3,158,213	14%

Measure L	4,966,535	23%	5,726,066	25%	5,726,066	25%	5,726,066	25%	5,726,066	25%
Tourism Impact Funds - District Grants	500,535	2%	572,607	3%	572,607	3%	572,607	3%	572,607	3%
Roads Repairs and Improvements	1,000,000	5%	1,145,213	5%	1,145,213	5%	1,145,213	5%	1,145,213	5%
Regional Parks Department	1,000,000	5%	1,145,213	5%	1,145,213	5%	1,145,213	5%	1,145,213	5%
Fire Services	1,000,000	5%	1,145,213	5%	1,145,213	5%	1,145,213	5%	1,145,213	5%
Affordable Housing	621,000	3%	744,389	3%	744,389	3%	744,389	3%	744,389	3%
Veteran's Buildings/Event Facilities	460,000	2%	515,346	2%	515,346	2%	515,346	2%	515,346	2%
Code Enforcement and Compliance	385,000	2%	458,085	2%	458,085	2%	458,085	2%	458,085	2%

Existing General Fund	4,971,415	23%	5,726,066	25%	5,726,066	25%	5,726,066	25%	5,726,066	25%
-----------------------	-----------	-----	-----------	-----	-----------	-----	-----------	-----	-----------	-----

TOT Allocated	21,448,600	107%	22,968,843	100.3%	22,904,266	100%	22,904,266	100%	22,904,266	100%
TOT Projected	20,022,535		22,904,266		22,904,266		22,904,266		22,904,266	

FY 2018-19 Sonoma County Community Investment Fund Approved Grant Awards

Entity	Description of Funding Need	District	FY17-18 Grant Award	Amount Requested for FY18-19	Approved Award
Economic and Workforce Development					
Chambers of Commerce					Max: \$40,000
Cloverdale Chamber	10% Membership Match. Multi-Year grant for 3 years, FY18-19 through FY20-21. Funding will be determined each fiscal year, but organization does not need to re-apply for this period.	4	\$2,604	\$7,750	\$2,900
Geyserville Chamber	10% Membership Match. Multi-Year grant for 3 years, FY18-19 through FY20-21. Funding will be determined each fiscal year, but organization does not need to re-apply for this period.	4	\$2,095	\$2,367	\$2,425
Hispanic Chamber	10% Membership Match. Multi-Year grant for 3 years, FY18-19 through FY20-21. Funding will be determined each fiscal year, but organization does not need to re-apply for this period.	All	N/A	\$10,000	\$3,100
Mark West Chamber	10% Membership Match. Multi-Year grant for 3 years, FY18-19 through FY20-21. Funding will be determined each fiscal year, but organization does not need to re-apply for this period.	4	\$1,800	\$2,000	\$1,600
Monte Rio Chamber	10% Membership Match. Multi-Year grant for 3 years, FY18-19 through FY20-21. Funding will be determined each fiscal year, but organization does not need to re-apply for this period.	5	\$223	\$275	\$275
Russian River Chamber and Visitor Center	10% Membership Match. Multi-Year grant for 3 years, FY18-19 through FY20-21. Funding will be determined each fiscal year, but organization does not need to re-apply for this period.	5	\$4,442	\$5,300	\$4,000
Sebastopol Chamber and Visitor Center	10% Membership Match. Multi-Year grant for 3 years, FY18-19 through FY20-21. Funding will be determined each fiscal year, but organization does not need to re-apply for this period.	5	\$5,766	\$4,000	\$4,000
Sonoma Valley Chamber	10% Membership Match. Multi-Year grant for 3 years, FY18-19 through FY20-21. Funding will be determined each fiscal year, but organization does not need to re-apply for this period.	1	\$16,151	\$20,000	\$14,500
Windsor Chamber	10% Membership Match. Multi-Year grant for 3 years, FY18-19 through FY20-21. Funding will be determined each fiscal year, but organization does not need to re-apply for this period.	4	\$5,803	\$40,000	\$7,200
		Total	\$40,000	\$91,692	\$40,000

FY 2018-19 Sonoma County Community Investment Fund Approved Grant Awards

Entity	Description of Funding Need	District	FY17-18 Grant Award	Amount Requested for FY18-19	Approved Award
Visitors Centers					Max: N/A
Cloverdale Chamber of Commerce	Visitors Center Funding. Multi-Year grant for 3 years, FY18-19, FY19-20, and FY20-21.	4	\$10,000	\$30,000	\$10,000
Geyserville Chamber of Commerce	Visitors Center Funding. Multi-Year grant for 3 years, FY18-19, FY19-20, and FY20-21.	4	\$6,200	\$12,600	\$6,200
Healdsburg Chamber of Commerce and Visitor Center	Visitors Center Funding. Multi-Year grant for 3 years, FY18-19, FY19-20, and FY20-21.	4	\$10,000	\$25,000	\$10,000
Hispanic Chamber of Commerce	Visitors Center Funding.	All	N/A	\$35,000	\$0
Mark West Chamber of Commerce	Visitors Center Funding.	4	N/A	\$1,500	\$0
Petaluma Visitors Program	Visitors Center Funding. Multi-Year grant for 3 years, FY18-19, FY19-20, and FY20-21.	2	\$10,000	\$22,600	\$12,000
Russian River Chamber of Commerce and Visitor Center	Visitors Center Funding. Multi-Year grant for 3 years, FY18-19, FY19-20, and FY20-21.	5	\$78,800	\$102,600	\$80,800
Santa Rosa Visitor Center	Visitors Center Funding. Multi-Year grant for 3 years, FY18-19, FY19-20, and FY20-21.	3	\$31,000	\$31,000	\$31,000
Sebastopol Chamber of Commerce and Visitor Center	Visitors Center Funding. Multi-Year grant for 3 years, FY18-19, FY19-20, and FY20-21.	5	\$12,700	\$30,000	\$12,700
Sonoma Coast Visitor Center	Visitors Center Funding. Multi-Year grant for 3 years, FY18-19, FY19-20, and FY20-21.	5	\$82,900	\$82,000	\$82,000
Sonoma Valley Visitors Bureau	Visitors Center Funding. Multi-Year grant for 3 years, FY18-19, FY19-20, and FY20-21.	1	\$94,000	\$150,000	\$95,700
Windsor Chamber and Visitor Center	Visitors Center Funding. Multi-Year grant for 3 years, FY18-19, FY19-20, and FY20-21.	4	\$5,000	\$19,371	\$7,000
Total			\$342,400	\$541,671	\$347,400

FY 2018-19 Sonoma County Community Investment Fund Approved Grant Awards

Entity	Description of Funding Need	District	FY17-18 Grant Award	Amount Requested for FY18-19	Approved Award
Economic Development					Max: N/A
Economic Development Board	The Economic Development Board provides business assistance services to enable local businesses to maintain and expand their operations.		\$2,809,413	\$3,158,213	\$3,158,213
Total			\$2,809,413	\$3,158,213	\$3,158,213
Tourism Marketing Program					Max: N/A
Sonoma County Tourism	Per Community Investment Grant Program Policy, 1.25% of the first 9% of TOT revenue is allocated to Sonoma County Tourism for advertising and promotional efforts of Sonoma		\$3,117,576		\$2,107,840
Total			\$3,117,576		\$2,107,840
Visitor Way Finding and Signage					Max: \$100,000
Bodega Volunteer Fire Department	"Welcome to Bodega, CA" signs and a sign identifying the fire station	5	N/A	\$25,000	\$25,000
Fountaingrove District Winegrower Association	Signage for vineyards located in the Fountaingrove District	1,3	\$14,000	\$25,000	\$0
Geyserville Chamber	Directional signs for traffic from Dry Creek Road and Highway 128, business directory sign for downtown Geyserville, and various other signage	4	\$5,000	\$10,000	\$10,000
Petaluma Visitors Program	Replacement and addition of signage at the Petaluma Visitors Center	2	\$25,000	\$11,300	\$10,000
Sonoma Arts Live	Identifying signage for theater	1	N/A	\$5,000	\$0
Sonoma County Fair	Replace marquee sign at main entrance to the Sonoma County Fairgrounds	3	N/A	\$50,000	\$29,000
Sonoma Land Trust	Permanent signage for lands located at Sears Point Ranch and Glen Oaks Ranch	1,2	N/A	\$12,500	\$6,000
Sonoma Valley Historical Society Inc.	Digital way-finding program that identifies heritage tourism locations in Sonoma Valley	1	N/A	\$15,000	\$0
Sonoma Valley Vintners & Growers Alliance	Replace all winery directional arrows in Sonoma Valley	1	N/A	\$34,000	\$10,000
Sonoma Valley Visitors Bureau	Replace "Welcome to Sonoma Valley" signs	1	N/A	\$10,000	\$10,000
Winegrowers of Dry Creek Valley	Signage for vineyards located in Dry Creek Valley	4	\$15,000	\$15,000	\$0
Total			\$100,000	\$212,800	\$100,000

FY 2018-19 Sonoma County Community Investment Fund Approved Grant Awards

Entity	Description of Funding Need	District	FY17-18 Grant Award	Amount Requested for FY18-19	Approved Award
Workforce Development and Scholarships					Max: \$500,000
10,000 Degrees	This is a Multi-Year grant through FY 20-21. 10,000 Degrees Sonoma County College Prep, Access & Success Expansion Project. Support 30% of students from low-income families to enable them to attend and graduate from college.	All	\$150,000	\$100,000	\$100,000
Becoming Independent	Employing Abilities Workforce Program. Provide workforce training for individuals with intellectual or developmental disabilities. Request is for \$80,000 per year for three fiscal years (\$240,000 total). Recommending \$50,000 per year for 3 fiscal years.	All	\$0	\$80,000	\$50,000
California Indian Museum and Cultural Center	Tribal Ambassadors through Business project. Provides employment training to at-risk Native American youth ages 15-24 in Sonoma County. Request is for \$50,000 per year for three fiscal years (\$150,000 total).	All	N/A	\$50,000	\$0
Career Technical Education Foundation (CTE)	Workforce and Educational Strategies to Support Economic Recovery. Funds would support the following activities: participation in County Economic Recovery Planning Efforts, expansion of the North Bay Construction Corps, expand access to Work-Based Learning system, and develop new CTE sections (STEM). Request is for \$200,000 per year for three fiscal years (\$600,000 total). Recommending \$150,000 per year for 3 fiscal years.	All	\$50,000	\$200,000	\$150,000
Cinco de Mayo Santa Rosa Inc.	Scholarship program focusing on Latino students in underserved communities such as in the Roseland community.	All	N/A	\$10,000	\$0
Creative Sonoma Summer Arts Grants	Summer Arts Youth Program Grants to creative organizations fostering creativity and learning in local youth over the summer months.	All	\$100,000	\$150,000	\$100,000
Creative Sonoma Arts Education Grants	Arts Education Innovation Grants supports new and innovative ideas that engage underserved Sonoma County, California students, ages 2-18, through providing access to high-quality arts education.	All	\$24,000	\$50,000	\$25,000
Daily Acts Organization	Rebuilding Hope and Growing Green Jobs, One Garden at a Time Program to provide green job training to students and underserved young adults. Installation of 35 sustainable landscapes at fire-impacted homes in Sonoma County. In partnership with North Bay Conservation Corps and Career Technical Education Foundation.	All	N/A	\$131,259	\$20,000
Geyserville Chamber of Commerce	Scholarship program for Geyserville New Tech graduates who have volunteered with the Chamber and are going to attend college or trade school. Scholarships will be based on community service hours, grades, extra-curricular activities, and acceptance to college or trade school.	4	N/A	\$15,000	\$0

FY 2018-19 Sonoma County Community Investment Fund Approved Grant Awards

Entity	Description of Funding Need	District	FY17-18 Grant Award	Amount Requested for FY18-19	Approved Award	
Geyserville Odd Fellows #176	Scholarship program for Geyserville students to attend college or trade school. Scholarships based on merit and need.	4	N/A	\$6,000	\$0	
Hispanic Chamber of Commerce	Scholarship program for Sonoma County Latino students.	All	N/A	\$25,000	\$0	
LIME Foundation	Scholarship program for students to attend the NextGen Trades Academy. The Academy offers seven months of youth training in vocational trades such as construction, architecture, plumbing, roofing, green building, and solar technology.	All	N/A	\$25,350	\$25,350	
Los Cien Sonoma County Inc.	Scholarship program to allow students and families to attend Annual State of the Latino Community event.	All	N/A	\$5,000	\$4,650	
Russian River Chamber of Commerce	Business Workshop Series. Providing business skills such as marketing, social media, accounting, and technology for Russian River area businesses.	5	N/A	\$3,500	\$0	
Santa Rosa Chamber of Commerce - Mike Hauser Algebra Academy	This is a Multi-Year grant through FY 18-19. Algebra preparatory program and expansion for 8th & 9th graders in Sonoma County for whom English is a second language. 60% of enrolled students qualify as low income.	All	\$25,000	\$25,000	\$25,000	
Santa Rosa Symphony	Scholarship program for Training Young Musicians. Focused on serving students from underserved communities. Program emphasizes community engagement, responsibility, and teamwork.	All	N/A	\$15,000	\$0	
Sonoma Community Center	Master Artist Series of arts education workshops. Funds will be used for scholarships for seniors. Request is for \$12,000 per year for two fiscal years (\$24,000 total).	1	N/A	\$12,000	\$0	
Sonoma Valley Education Foundation	Youth Engagement Seminar, a two-week summer program focusing on leadership and civic engagement for students at Sonoma Valley High School.	1	N/A	\$14,256	\$0	
Sonoma Valley Education Foundation	Program to support STEM Career Academies at Sonoma Valley High School - Engineering, Design, and Technology Academy and AgriTechnology Academy. The program provides work-based learning opportunities.	1	N/A	\$50,000	\$0	
Teen Services Sonoma	Teen Services Sonoma Ready-to-Work Workforce Development Programs. Provides multi-tiered job readiness and career exploration for youth ages 14-24 in Sonoma Valley.	1	N/A	\$34,504	\$0	
Total				\$350,000	\$1,001,869	\$500,000

FY 2018-19 Sonoma County Community Investment Fund Approved Grant Awards

Entity	Description of Funding Need	District	FY17-18 Grant Award	Amount Requested for FY18-19	Approved Award
Community Services and Safety					
Parks, Recreation, and Event Facilities					Max: N/A
Regional Parks Department	Operations and Maintenance of existing facilities		\$2,651,507	\$2,651,507	\$2,651,507
Total			\$2,651,507	\$2,651,507	\$2,651,507
Community Non-Profit Grants					
Agricultural Promotion					Max: \$185,000
Petaluma Bounty (Petaluma Peoples Services Center)	Produce video promoting Sonoma County Farmers' Markets, and expansion of "Faces of the Market" campaign	All	N/A	\$26,000	\$14,000
Russian River Chamber of Commerce	Produce brochure promoting lower Russian River wineries	5	N/A	\$4,400	\$4,000
Sonoma County Farm Trails	Promotion of Sonoma County Farm Trails events	All	N/A	\$30,000	\$30,000
Sonoma County Harvest Fair	Promotion of Sonoma County Harvest Fair	3	N/A	\$30,000	\$10,000
Sonoma County Vintners	Promotion of Sonoma County wineries and of Sonoma County as a tourist destination	All	N/A	\$58,000	\$58,000
Sonoma Valley Vintners & Growers Alliance	Promotion of Sonoma Valley and development of the Sonoma Valley brand	1	N/A	\$24,700	\$24,000
Wine Road Northern Sonoma County	Promotion of wineries in Alexander, Dry Creek, and Russian River Valleys	4,5	N/A	\$60,000	\$10,000
Winegrowers of Dry Creek Valley	Promotion of 30th Annual Passport to Dry Creek Valley	4	N/A	\$25,000	\$10,000
Total			\$185,000	\$258,100	\$160,000
Historical Commissions					Max: \$60,000
Bodega Volunteer Fire Department	Post office preservation		N/A	\$50,000	\$0
Historical Records Commission	Ongoing historical record preservation		\$10,000	\$15,000	\$10,000
Landmarks Commission	Funding for preservation and restoration of historically significant buildings. Projects: Jack London Cottage porch restoration, Bosworth House chimney repair, Saw Mill Teepee rehabilitation, Marcy House re-roof, Petaluma Adobe stabilization, The Sea Ranch historic resources survey, and Henry N. Wallace collection inventory.		\$50,000	\$50,000	\$50,000
Total			\$60,000	\$115,000	\$60,000

FY 2018-19 Sonoma County Community Investment Fund Approved Grant Awards

Entity	Description of Funding Need	District	FY17-18 Grant Award	Amount Requested for FY18-19	Approved Award
Local Events, Organizations, and Economic Development Grants					Max: \$250,000
District 1	Assists small cultural, artistic, and countywide events and organizations with funding for advertising and economic development efforts to promote Sonoma County and encourage visitors to frequent the county throughout the entire year. Funds may also be used for activities that support community organizations. Funding recommendations are made at the discretion of each Supervisorial District.		\$50,000	\$50,000	\$50,000
District 2			\$50,000	\$50,000	\$50,000
District 3			\$50,000	\$50,000	\$50,000
District 4			\$50,000	\$50,000	\$50,000
District 5			\$50,000	\$50,000	\$50,000
Total			\$250,000	\$250,000	\$250,000
Major County Events and Organizations					Max: \$300,000
6th Street Playhouse	2018-2019 Season	All	\$10,000	\$50,000	\$10,000
Green Music Center at Sonoma State University	Summer 2018 and Fall/Winter 2018-2019 seasons	All	\$18,000	\$50,000	\$20,000
Healdsburg Jazz Festival Inc.	Year-round programming and 2019 Healdsburg Jazz Festival	4	\$10,000	\$25,000	\$10,000
Jack London Park Partners (Valley of the Moon Natural History Association)	55th Anniversary of Historic Park status and re-opening of the park's museum, House of Happy Walls	1	N/A	\$24,000	\$0
King Ridge Foundation	Levi's GranFondo cycling and running event (October 5-7, 2018)	3,5	\$0	\$50,000	\$0
KRCB North Bay Public Media	Documentary multi-media project about the history and legacy of the Works Progress Administration in Sonoma County	3	\$0	\$50,000	\$0
Luther Burbank Center for the Arts	2018-2019 Season	All	\$50,000	\$50,000	\$50,000
Luther Burbank Rose Parade & Festival	125th Luther Burbank Rose Parade & Festival	3	\$5,000	\$10,000	\$0
Museums of Sonoma County	2018-2019 series of exhibitions including an anniversary exhibition of the 2017 firestorm	All	\$40,000	\$50,000	\$40,000
My American DREAMS Foundation	Documentary films about Sonoma County immigrant youth	All	\$0	\$5,000	\$0
Pacific Coast Air Museum	Events series including Wings Over Wine Country, climb aboards, Aviation Summer School, September 11th Commemoration, Veteran's Day, and Santa Fly-in	4	\$10,000	\$20,000	\$10,000
Petaluma Downtown Association	Four events: Art & Garden Festival, two Antique Faires, Butter & Egg Days Parade	2	\$5,000	\$14,000	\$5,000
Russian River Chamber of Commerce	Documentary film series - Inspired: Russian River Valley	5	N/A	\$50,000	\$0
Santa Rosa Symphony	91st Season - year-round concert series and special events including Classical Concert Series, Family Concert Series, Pops Concert Series, Youth Orchestra Concerts, and Music Education Concerts	3	\$50,000	\$50,000	\$50,000
Sebastopol Center for the Arts	Year round visual, performing, literary, and film arts activities and events	5	\$25,000	\$50,000	\$25,000
Sonoma County Fairgrounds	2018 Sonoma County Fair	All	\$40,000	\$50,000	\$30,000
Sonoma County Farm Trails	45th Annual Gravenstein Apple Fair	All	\$13,000	\$20,000	\$20,000

FY 2018-19 Sonoma County Community Investment Fund Approved Grant Awards

Entity	Description of Funding Need	District	FY17-18 Grant Award	Amount Requested for FY18-19	Approved Award
Sonoma County Hot Air Balloon Classic	Sonoma County Hot Air Balloon Classic	4	N/A	\$15,000	\$0
Sonoma Ecology Center	Activities at Sugarloaf Ridge State Park, including special events and hikes	1	N/A	\$10,800	\$5,000
Sonoma International Film Festival	Sonoma International Film Festival (March 27-April 1, 2019)	1	\$10,000	\$25,000	\$10,000
Sonoma Volunteer Firefighters Association	Sonoma Valley 4th of July Parade & Festival with Fireworks Show	1	N/A	\$10,000	\$0
Summer Repertory Theatre Festival	2018 Season	3	\$10,000	\$15,000	\$10,000
Transcendence Theatre Company	Broadway Under the Stars - four performances - Stairway to Paradise, Fantastical Family Night, Shall We Dance, and Gala Celebration	1	N/A	\$50,000	\$5,000
Visit Santa Rosa and the City of Santa Rosa	IRONMAN events (May 11, 2018 and July 28, 2018)	2,3,4,5	\$50,000	\$50,000	\$0
Total				\$350,000	\$793,800
Seasonal and Off Peak Programs					Max: \$50,000
6th Street Playhouse	2018-2019 Off-Peak Season	All	N/A	\$5,000	\$0
Alexander Valley Film Society	Alexander Valley Film Festival	4	\$5,000	\$5,000	\$5,000
Bodega Bay Area Chamber of Commerce	Off season events including Crab Weekend	5	N/A	\$4,000	\$2,500
Bodega Bay Fisherman's Festival	Bodega Bay Fisherman's Festival	5	N/A	\$5,000	\$2,500
Bodega Volunteer Fire Department	Six events including dinners, all day festival, and crafts faire	5	N/A	\$5,000	\$2,500
Cinco de Mayo Santa Rosa Inc.	13th Annual Cinco de Mayo	3	N/A	\$5,000	\$2,500
Cinnabar Theater	The Great Petaluma Chili Cookoff	2	N/A	\$5,000	\$0
Cinnabar Theater	Night & Day event commemorating the music of Cole Porter	2	N/A	\$5,000	\$0
Cloverdale Chamber of Commerce	4th Annual 2018 Winter Festival	4	N/A	\$5,000	\$2,500
Cloverdale Citrus Fair	Cloverdale Citrus Fair	4	N/A	\$5,000	\$5,000
Corazon Healdsburg	Scopa Has a Dream event	4	N/A	\$10,000	\$0
Geyserville Chamber of Commerce	Four events: May Day; Wine, Beer and Spirits Festival; Fall Colors; Tractor Parade	4	N/A	\$10,000	\$0
Luther Burbank Center for the Arts (Luther Burbank Memorial Foundation)	Sonoma Strong Live Arts series	All	N/A	\$5,000	\$0
Main Stage West (Performing Artists Coalition for Theater)	Year-round performances	5	N/A	\$5,000	\$2,500

FY 2018-19 Sonoma County Community Investment Fund Approved Grant Awards

Entity	Description of Funding Need	District	FY17-18 Grant Award	Amount Requested for FY18-19	Approved Award
Monte Rio Chamber of Commerce	Three events: July 4th Weekend activities, Casino Night, and 18th Annual Charity Golf Tournament	5	N/A	\$5,000	\$5,000
Old Time Fiddle Fest (Cloverdale Citrus Fair)	42nd Cloverdale Old Time Fiddle Festival	4	N/A	\$2,500	\$0
Petaluma Museum Association	Year-round special events to celebrate 40th Anniversary of the Petaluma Historical Library & Museum	2	N/A	\$5,000	\$5,000
Railroad Square Music Festival	5th Annual Railroad Square Music Festival	3	N/A	\$5,000	\$0
Russian River Chamber of Commerce	Russian River Food & Wine Spring Fling	5	\$2,500	\$2,500	\$2,500
Sebastopol Area Senior Center	Holiday Store and Legacy Thrift Shop	5	N/A	\$2,765	\$0
Sebastopol Center for the Arts (Sonoma County Art Trails)	Sonoma County Art Trails	All	\$5,000	\$5,000	\$5,000
Sonoma Arts Live Theater Company	2018-2019 season	1	\$2,500	\$4,000	\$2,500
Sonoma County Farm Trails	Holidays Along the Farm Trails	All	\$5,000	\$5,000	\$0
Sonoma Valley Visitors Bureau	Holiday Lighting of the Plaza	1	N/A	\$5,000	\$2,500
Town of Windsor	Holiday Lights event, Month of Love Lights event	4	N/A	\$5,000	\$2,500
Town of Windsor	18th Annual Windsor Holiday and Tree Lighting Celebration	4	N/A	\$2,500	\$0
Wine Road Northern Sonoma County	Two events: 27th Annual Winter Wonderland, 42nd Annual Barrel Tasting	4	N/A	\$20,000	\$0
Winegrowers of Dry Creek Valley	Dry Creek Valley Winter Getaway Promotion	4	\$0	\$5,000	\$0
Total				\$25,000	\$153,265
					\$50,000

FY 2018-19 Sonoma County Community Investment Fund Approved Grant Awards

Entity	Description of Funding Need	District	FY17-18 Grant Award	Amount Requested for FY18-19	Approved Award
Program Integrity and Administration					
Collections/Audit Services					Max: N/A
ACTTC - Collections	Tax collection administration activities. Includes 40,000 for Extra Help for collections activities.		\$407,819	\$407,819	\$407,819
ACTTC - Audit	Audit services including program grant audits, collection audits and vacation rentals.		\$114,100	\$114,100	\$114,100
Total			\$521,919	\$521,919	\$521,919
Legal Services					
County Counsel					Max: N/A
County Counsel	Program and collections legal services		\$41,810	\$41,810	\$41,810
Total			\$41,810	\$41,810	\$41,810
Additional Expenditures					
FY 17-18 One-Time Behavioral Health Back-Fill					Max: N/A
FY 17-18 One-Time Behavioral Health Back-Fill	Transient Occupancy Tax funds were used to back-fill Department of Health Services budget shortfall for FY 17-18. No funds are included in the FY 18-19 Community Investment Grant Program budget.		\$925,000	N/A	N/A
CAO Office of Recovery and Resiliency	Funding to support staffing for the CAO Office of Recovery and Resiliency		\$124,899	\$271,961	\$271,961
Total			\$1,049,899	\$271,961	\$271,961
Reserves					
Allocate to Economic Uncertainty Reserve Fund					Max: N/A
Allocate to Economic Uncertainty Reserve Fund	Economic Uncertainty Revenue Fund contains \$1,032,201, or 10% of the total revenue of the first 9% of Transient Occupancy Tax. No additional contribution will be made to this Fund in FY		\$0	N/A	\$0
Allocate to Contingencies					Max: N/A
Allocate to Contingencies	\$50,000 of available contingencies for FY 18-19		\$50,000	N/A	\$50,000
Total			\$50,000	\$0	\$50,000

FY 2018-19 Sonoma County Community Investment Fund Approved Grant Awards

Entity	Description of Funding Need	District	FY17-18 Grant Award	Amount Requested for FY18-19	Approved Award
Measure L Revenue					
MEASURE L - 3% FUNDING					Total Available: \$4,966,535
Roads Repair and Improvement	Allocated to Transportation and Public Works for improvements to local roads.		\$1,000,000		\$1,000,000
Regional Parks Department	Funding will be prioritized to increase public access and support the development of new park facilities.		\$1,000,000		\$1,000,000
Fire and Emergency Services	To help alleviate the strain and to encourage greater regional consolidation within the county's fire system, funds will be available to support the Board's approval of a plan to establish an efficient, effective, and sustainable fire services delivery model.		\$1,000,000		\$1,000,000
Affordable Housing	Funds shall be allocated to the existing County Fund for Housing as well as to homeless service needs, administered by the Community Development Commission.		\$621,000		\$621,000
Event Facilities Improvements	Funds will be used to enhance recreational activities that benefit local tourism and the tourist industry, including, but not limited to, Veterans Halls (under contract or managed by the General Services Department).		\$460,000		\$460,000
Auditor-Controller Treasurer-Tax Collector - Collections	Funds two positions to enhance capacity to collect Transient Occupancy Tax.		\$218,000		\$218,000
Permit and Resource Management	Permit Sonoma and Auditor-Controller Treasurer-Tax Collector shared staff, creating a "one-stop shop" for vacation rentals and Transient Occupancy Tax collections.		\$61,000		\$61,000
Permit and Resource Management	"Data scrape" to search internet hosting sites to identify non-compliant Transient Occupancy Tax operators (service provided through a contracted entity).		\$76,000		\$17,000
Permit and Resource Management	Night/Weekend Code Enforcement for Vacation Rental Services - Code Enforcement by a private contractor for night/weekend vacation rentals.		\$30,000		\$89,000
Tourism Impact Fund	Funds will be used to meet unique and urgent needs of areas within unincorporated Sonoma County that are most impacted by tourism.		\$500,000		\$500,535
Total			\$4,966,000		\$4,966,535
Total Expenditures					\$15,577,185
Revenues					
FY 18-19 Projected Transient Occupancy Tax Collections	9% of the total 12% Transient Occupancy Tax collections (67% of total as 33% goes to General Fund).				\$10,087,520
FY 18-19 Measure L Projected Transient Occupancy Tax Collections	3% of the total 12% Measure L Transient Occupancy Tax collections.				\$4,966,535
Utilized Available Fund Balance	Utilization of Fund Balance.				\$523,130
Total Revenue					\$15,577,185

FY 2017-18 Sonoma County Community Investment Program Approved Grant Awards

Entity	Description of Funding Need	16/17 Ad Grant	Amount Requested for FY 17/18	Board of Supervisors Approved Awards
Category A1 - Chambers of Commerce				Max: \$40,000
Cloverdale Chamber	10% Membership Match	\$3,000	\$2,800	\$2,604
Geyserville Chamber	10% Membership Match	\$2,050	\$2,253	\$2,095
Mark West Chamber	10% Membership Match	\$2,000	\$2,000	\$1,800
Monte Rio Chamber	10% Membership Match	\$190	\$240	\$223
North Bay Black Chamber	10% Membership Match	N/A	\$1,200	\$1,116
Russian River Chamber and Visitor Center	10% Membership Match	\$6,000	\$4,776	\$4,442
Sebastopol Chamber and Visitors Center	10% Membership Match	\$6,500	\$7,000	\$5,766
Sonoma Valley Chamber	10% Membership Match	\$19,500	\$17,500	\$16,151
Windsor Chamber	10% Membership Match	N/A	\$6,240	\$5,803
Total			\$44,009	\$40,000
Category A2 - Visitors Center				Max: N/A
Cloverdale Chamber of Commerce	Visitors Center Funding	\$10,000	\$21,950	\$10,000
Geyserville Chamber of Commerce	Visitors Center Funding	\$6,500	\$10,000	\$6,200
Healdsburg Chamber of Commerce and Visitor Center	Visitors Center Funding	\$10,000	\$30,000	\$10,000
Petaluma Visitors Program	Visitors Center Funding	\$10,000	\$26,677	\$10,000
Redwood Coast Chamber of Commerce and Visitor Center	Visitors Center Funding	\$6,750	\$16,692	\$6,800
Russian River Chamber of Commerce and Visitor Center	Visitors Center Funding	\$78,800	\$100,000	\$78,800
Santa Rosa Visitor Center	Visitors Center Funding	\$31,000	\$31,000	\$31,000

FY 2017-18 Sonoma County Community Investment Program Approved Grant Awards

Entity	Description of Funding Need	16/17 Ad Grant	Amount Requested for FY 17/18	Board of Supervisors Approved Awards
Sebastopol Area Chamber of Commerce	Visitors Center Funding	\$13,350	\$30,000	\$12,700
Sonoma Coast Visitor Center	Visitors Center Funding	\$82,000	\$90,000	\$77,900
Sonoma Valley Visitor Bureau	Visitors Center Funding	\$94,000	\$130,000	\$94,000
Windsor Chamber of Commerce and Visitor Center	Visitors Center Funding	N/A	\$26,475	\$5,000
Total			\$512,794	\$342,400
Category A3 - Economic Development				Max: N/A
Economic Development Board	The Economic Development Board provides business assistance services to enable local businesses to maintain and expand their operations.	\$2,476,215	\$2,809,413	\$2,809,413
Sonoma County Lodging Association	Funds used for part-time director.	\$35,000	\$35,000	\$0
Total			\$2,844,413	\$2,809,413
Category A4 - Tourism Marketing Program				Max: N/A
Sonoma County Tourism	Advertising and promotional efforts. <i>Funding for Sonoma County Tourism is currently be evaluated by the Board of Supervisors and may be adjusted in FY 17-18.</i>	\$3,117,576	\$3,346,444	\$3,117,576
Total			\$3,346,444	\$3,117,576

FY 2017-18 Sonoma County Community Investment Program Approved Grant Awards

Entity	Description of Funding Need	16/17 Ad Grant	Amount Requested for FY 17/18	Board of Supervisors Approved Awards
Category A5 - Visitor Way Finding & Signage				Max: \$100,000
Fountaingrove District Winegrower Association	Permit and install AVA boundary signage at 5 major entry points to Fountaingrove District.	N/A	\$14,000	\$14,000
Geyserville Chamber	Business detail signs on main street of town, pointing tourists in the direction of businesses & visitor center.	\$4,000	\$5,000	\$5,000
Museums of Sonoma County	Permanent signage on B and 7th streets, identifying buildings of History and Art museums to direct public to entrances.	\$10,000	\$15,000	\$15,000
Petaluma Visitors Program	Replacement of "I" banners on light poles adjacent to Visitors Center.	\$10,000	\$2,437	\$2,500
Russian River Chamber	Kiosk in plaza, banners on light poles.	\$20,000	\$32,600	\$16,000
Sebastopol Center for the Arts	Second side of a two-sided monument sign with LED display to be placed in front of the Veterans Memorial and Sebastopol Center for the Arts buildings.	\$7,500	\$13,000	\$13,000
Sonoma Ecology Center	Sonoma Garden Park area identification signage.	\$10,000	\$12,000	\$12,000
Sonoma Valley Visitor Bureau	Signage to be located in rented advertising areas of BART stations and trains.	\$20,500	\$40,000	\$0
Windsor Chamber of Commerce	Outdoor, all weather kiosk.	N/A	\$7,500	\$7,500
Winegrowers of Dry Creek Valley	Replacement of 130 Winegrape Grower signs to include "Dry Creek Valley"	\$10,000	\$15,000	\$15,000
Total			\$156,537	\$100,000

FY 2017-18 Sonoma County Community Investment Program Approved Grant Awards

Entity	Description of Funding Need	16/17 Ad Grant	Amount Requested for FY 17/18	Board of Supervisors Approved Awards
Category A6 - Workforce Development and Scholarships				Max: \$400,000
10,000 Degrees	This is a Multi-Year grant through FY 20-21. 10,000 Degrees Sonoma County College Prep, Access & Success Expansion Program	\$150,000	\$100,000	\$100,000
Career Technical Education Foundation - Regional Advanced	This is a Multi-Year grant through FY 17-18. Regional Advanced Mechanics Program: Regional manufacturing training program to support local manufacturing needs for technicians and mechanics. Funding for program development, grants to high schools and SRJC for equipment, new course implementation, teacher externships and internship opportunities for students.	\$50,000	\$50,000	\$50,000
Creative Sonoma Summer Arts Grants	Summer Arts Youth Grants	\$100,000	\$100,000	\$100,000
Creative Sonoma Arts Education Grants	Program to support equitable access arts education for underserved Sonoma County schools	\$24,000	\$24,000	\$24,000
Community Foundation: Education/Mentorship (CTE)	This is a Multi-Year grant through FY 17-18. Career Technical Education: "New" courses at high schools and off campuses to develop local workforce in engineering/design or Advanced Tech & Manufacturing (STEM) county-wide.	\$51,000	\$51,000	\$51,000
Santa Rosa Chamber of Commerce - Mike Hauser Algebra Academy	This is a Multi-Year grant through FY 18-19. Algebra prep program and expansion for 8th & 9th graders in Sonoma County for whom English is a second language. 60% of enrolled students qualify as low income.	\$25,000	\$25,000	\$25,000
Sonoma County Grape Growers Foundation	Latino Vineyard Employee Management and Job Training Program: Sonoma County Ag Management Training (SCAMT). Request is for \$150,000 over 3 years (\$50,000 per year)	N/A	\$150,000	\$0
Becoming Independent	Employing Abilities Workforce Program. Request is for \$132,600 over 2 years (\$66,300 per year).	N/A	\$132,600	\$0
Total			\$632,600	\$350,000

FY 2017-18 Sonoma County Community Investment Program Approved Grant Awards

Entity	Description of Funding Need	16/17 Ad Grant	Amount Requested for FY 17/18	Board of Supervisors Approved Awards
Category B1 - Parks, Recreation and Event Facilities				Max: N/A
Regional Parks Department	Operations and Maintenance of existing facilities	\$2,651,507	\$2,651,507	\$2,651,507
Total			\$2,651,507	\$2,651,507
Category B2 - Community Impacts - Public Safety				Max: \$90,000
Bodega Bay Fire Protection District	Marine Electronics, Communications, Rescue Equipment/PPE, Training, Medical Equipment	\$15,000	\$90,000	\$15,000
Cazadero Community Services District	New roof and exhaust system for Station #1 Fire Hall and 4x4 brush truck	\$10,000	\$90,000	\$10,500
Geyserville Chamber of Commerce	Traffic sign	N/A	\$5,000	\$0
Monte Rio Fire Foundation	Two jet skis, trailer, and related equipment.	\$10,000	\$25,000	\$10,500
Russian River FPD	Purchase additional/upgrade swiftwater rescue equipment	\$20,000	\$36,330	\$15,000
Sonoma County FES (representing Volunteer Fire Companies in CSA#40)	Automatic External Defibrillators (AEDs)	N/A	\$39,060	\$39,000
Total			\$285,390	\$90,000

FY 2017-18 Sonoma County Community Investment Program Approved Grant Awards

Entity	Description of Funding Need	16/17 Ad Grant	Amount Requested for FY 17/18	Board of Supervisors Approved Awards
Category C - Agricultural Promotion				Max: \$185,000
Sonoma County Vintners group	Funds are managed by Sonoma County Vintners to promote collaborative advertising and promotional efforts with the agricultural sector. Sub-grant awards are distributed from the Sonoma County Vintners to: Sonoma County Winegrowers, Sonoma Valley Vintners and Growers, Sonoma County Farm Trails, Sonoma County Harvest Fair, Sonoma Wine Country Weekend, Wine Road Northern Sonoma County, and Winegrowers of Dry Creek Valley	\$185,000	\$185,000	\$160,000
Total			\$185,000	\$160,000
Category D - Historical Commissions				Max: \$60,000
Landmarks Commission	Funding for preservation and restoration of historically significant buildings.	\$50,000	\$50,000	\$50,000
Historical Records Commission	Ongoing historical record preservation	\$10,000	\$15,000	\$10,000
Museums of Sonoma County	Restoration project	N/A	\$4,000	\$0
Total			\$69,000	\$60,000
Category E - Local Events, Organizations and Economic Development				Max: \$250,000
District 1	Assists small cultural, artistic, and countywide events and organizations with funding for advertising and economic development efforts to promote Sonoma County and encourage visitors to frequent the county throughout the entire year.	\$46,472	\$50,000	\$50,000
District 2		\$18,216	\$50,000	\$50,000
District 3		\$20,280	\$50,000	\$50,000
District 4		\$31,504	\$50,000	\$50,000
District 5		\$53,528	\$50,000	\$50,000
Total			\$250,000	\$250,000

FY 2017-18 Sonoma County Community Investment Program Approved Grant Awards

Entity	Description of Funding Need	16/17 Ad Grant	Amount Requested for FY 17/18	Board of Supervisors Approved Awards
Category F - Major County Events and Organizations				Max: \$300,000
6th Street Playhouse	2017-18 Season	\$10,000	\$50,000	\$10,000
California Artisan Cheese Festival	California Artisan Cheese Festival	N/A	\$10,000	\$0
Cruisin' the Boulevard	Petaluma's Salute to American Graffiti	\$4,000	\$6,000	\$4,000
Green Music Center	2017-2018 Season	\$17,500	\$50,000	\$18,000
Healdsburg Jazz Festival, Inc.	Year round programming and 2018 Healdsburg Jazz Festival	\$10,000	\$45,000	\$10,000
King Ridge Foundation	Levi's GranFondo	N/A	\$50,000	\$0
Luther Burbank Center for the Arts	Luther Burbank Center for the Arts 2017-18 Season	\$45,000	\$50,000	\$50,000
Luther Burbank Rose Parade & Festival	Rose Parade and Festival	\$5,000	\$7,000	\$5,000
Museums of Sonoma County	10 major exhibitions	\$40,000	\$50,000	\$40,000
Pacific Coast Air Museum	Event series including Climb Aboards, Museum Open House, Flight Wing Hangar Talks, June Car Show, Aviation Summer School, September 11th Commemoration, Veteran's Day, and Santa Fly-in	\$10,000	\$10,000	\$10,000
Petaluma Downtown Association	4 Events: Art & Garden Festival, 2 Antique Faires, Butter & Egg Days Parade	\$5,000	\$14,000	\$5,000
Santa Rosa Symphony	90th Season - year round concert series and special events	\$50,000	\$50,000	\$50,000
Sebastopol Center for the Arts	20 art exhibitions, 12 music performances, 6 poetry events, 156 classes, film series, and at least 3 major events	\$25,000	\$50,000	\$25,000
Sonoma County Fair & Exposition, Inc.	Sonoma County Fair	\$40,000	\$50,000	\$40,000
Sonoma County Farm Trails	44th Annual Gravenstein Apple Fair	\$13,000	\$15,000	\$13,000
Sonoma International Film Festival	Sonoma International Film Festival	N/A	\$15,000	\$10,000
Sonoma Valley Visitors Bureau	Holidays in Sonoma Valley and Sonoma Valley Delicious!	N/A	\$50,000	\$0

FY 2017-18 Sonoma County Community Investment Program Approved Grant Awards

Entity	Description of Funding Need	16/17 Ad Grant	Amount Requested for FY 17/18	Board of Supervisors Approved Awards
Summer Repertory Theatre Festival	Summer Repertory Theatre Festival 2017 Season	\$5,000	\$15,000	\$10,000
Visit Santa Rosa (California Welcome Center SR)	IRONMAN triathlon events	N/A	\$50,000	\$50,000
Total			\$637,000	\$350,000
Category G1 - Department Activities				Max: N/A
Agricultural Commissioner	2018 CA State Fair Exhibit	\$20,000	\$27,098	\$14,000
Health Services Department	Russian River Blue Green Algae Monitoring	\$40,000	\$113,937	\$0
Sonoma County Fire and Emergency Services	SoCoAlert Marketing and Advertising	N/A	\$92,000	\$0
Sonoma County Library	Digital Photo Collection	\$25,000	\$50,000	\$0
Sonoma County Library	Table Top Scribe System and ST View Scan III	N/A	\$27,000	\$0
Total			\$196,098	\$14,000
Category G2 - Affordable Housing				Max: N/A
Set Aside Fund for Emergency Shelter	Maintained in Advertising Fund	\$60,000	\$60,000	\$60,000
Community Development Commission	Homeless Services - Funds Jones Hall (\$165,000)	\$165,000	\$165,000	\$165,000
Permit and Resource Management	Housing Element Implementation	\$150,000	\$150,000	\$150,000
Total			\$375,000	\$375,000

FY 2017-18 Sonoma County Community Investment Program Approved Grant Awards

Entity	Description of Funding Need	16/17 Ad Grant	Amount Requested for FY 17/18	Board of Supervisors Approved Awards
Category G3 - Collections/Audit Services				Max: N/A
ACTTC - Collections	Tax collection administration activities. Includes 40,000 for Extra Help for collections activities.	\$367,819	\$407,819	\$407,819
ACTTC - Audit	Audit services including program grant audits, collection audits and VRBO. Increased costs for audit in FY 17/18.	\$99,850	\$114,100	\$114,100
Total			\$521,919	\$521,919
Category G4 - Legal Services				Max: N/A
County Counsel	Program and collections legal services	\$51,810	\$41,810	\$41,810
Total			\$1,085,648	\$41,810
Category G5 - Program Administration				Max: N/A
CAO/BOS	Program staff support	\$432,093	\$576,068	\$576,068
Permit and Resource Management	Code Enforcement Vacation Rental Services	\$150,000	\$150,000	\$150,000
Total			\$726,068	\$726,068

FY 2017-18 Sonoma County Community Investment Program Approved Grant Awards

Entity	Description of Funding Need	16/17 Ad Grant	Amount Requested for FY 17/18	Board of Supervisors Approved Awards
Category H - Documentary Films				Max: \$30,000
Daily Acts Organization (application 1 of 2)	Film documenting the work done by Daily Acts Organization since its inception in 2002	N/A	\$10,000	\$0
Daily Acts Organization (application 2 of 2)	Community Resilience Challenge documentary	N/A	\$10,000	\$10,000
Human Rights Commission and KRCB	My American DREAMs Documentary films and Social Media Project	\$7,500	\$10,000	\$0
Inquiring Systems	Documentary film tracing the history of Sonoma Valley	N/A	\$10,000	\$10,000
KRCB North Bay Public Media	Three 3-minute documentary shorts promoting Sonoma County Regional Parks	\$10,000	\$10,000	\$0
Sonoma County Vintners	"Our Roots Grow Deep" - two or three 5-minute documentary videos	N/A	\$10,000	\$10,000
Winegrowers of Dry Creek Valley	Continue to document oral histories and evolution of the Dry Creek Valley wine region	\$5,000	\$10,000	\$0
Total			\$70,000	\$30,000
Category I - Seasonal and Off Peak Programs				Max: \$50,000
Alexander Valley Film Society	Alexander Valley Film Festival	\$5,000	\$5,000	\$5,000
Russian River Chamber of Commerce and Visitor Center	Spring Fling, Stumptown Daze Parade, Christmas Events	N/A	\$5,000	\$2,500
Sebastopol Center for the Arts (Art Trails)	Sonoma County Art Trails	\$5,000	\$5,000	\$5,000
Sebastopol Chamber of Commerce and Visitor Center	Apple Blossom Festival and Parade	\$5,000	\$5,000	\$5,000
Sonoma Arts Live Theater Company	Full Theatrical Season	N/A	\$5,000	\$2,500

FY 2017-18 Sonoma County Community Investment Program Approved Grant Awards

Entity	Description of Funding Need	16/17 Ad Grant	Amount Requested for FY 17/18	Board of Supervisors Approved Awards
Sonoma County Farm Trails	Holidays Along the Farm Trails	\$4,000	\$5,000	\$5,000
Sonoma County Vintners	Sonoma County Vintners Holiday Wine promotion	N/A	\$5,000	\$0
Sonoma Valley Vintners & Growers Alliance	Signature Sonoma Valley	N/A	\$15,000	\$0
Winegrowers of Dry Creek Valley	Dry Creek Valley - Winter Getaway Promotion	N/A	\$5,000	\$0
Total			\$55,000	\$25,000
Reserves				
Allocate to Economic Uncertainty Reserve Fund		\$300,000	N/A	\$0
Allocate to Contingencies	\$50,000 of available contingencies utilized on 6/20/17 (Balance is \$0)	\$300,000	N/A	\$0
Total to Reserves	Total Recommended			\$0
Total Expenditures				\$12,054,693
Revenues				
TOT Projected Collections	9% of the total 12% Transient Occupancy Tax collections			\$11,292,000
Utilized Available Fund Balance				\$682,693
One-Time Funds	Approved by the Board of Supervisors during FY 17-18 Budget Hearings			\$80,000
Total Revenues				\$12,054,693

FY 2017-18 Sonoma County Community Investment Program Approved Grant Awards

Entity	Description of Funding Need	16/17 Ad Grant	Amount Requested for FY 17/18	Board of Supervisors Approved Awards
MEASURE L - 3% FUNDING				Total Available: \$4,966,000
Roads Repair and Improvement	Allocated to Transportation and Public Works for improvements to local roads			\$1,000,000
Regional Parks Department	Funding will be prioritized to increase public access and support the development of new park facilities.			\$1,000,000
Fire and Emergency Services	To help alleviate the strain and to encourage greater regional consolidation within the county's fire system, funds will be available to support the Board's approval of a plan to establish and efficient, effective, and sustainable fire services delivery model.			\$1,000,000
Affordable Housing	Funds shall be allocated to the existing County Fund for Housing as well as to homeless service needs, administrated by the Community Development Commission.			\$621,000
Event Facilities Improvements	Funds will be used to enhance recreational activities that benefit local tourism and the tourist industry, including, but not limited to, Veterans Halls (under contract or managed by the General Services Department)			\$460,000
ACTTC - Collections	Add an additional 2.0 FTE's to enhance capacity to collect TOT.			\$218,000
Permit and Resource Management	PRMD - ACTTC shared staff, creating a "one-stop shop" for vacation rentals and TOT collections.			\$61,000
Permit and Resource Management	"Data scrape" that will search internet hosting sites to identify non-compliant TOT operators (service to be provided through a contracted entity).			\$76,000
Permit and Resource Management	Night/Weekend Code Enforcement for Vacation Rental Services - Code Enforcement by a private contractor for night/weekend vacation rentals.			\$30,000
Tourism Impact Fund	Funds will be used to meet unique and urgent needs of areas within unincorporated Sonoma County that are most impacted by tourism.			\$500,000
Total				\$4,966,000

FY 2016-17 Sonoma County Advertising Program Approved Grant Awards

Entity	Description of Funding Need	15-16 Advertising Grant	Amount Requested for 16-17	Approved Award
Category A1 - Chambers of Commerce				Max: \$40,000
Cloverdale Chamber	Membership match	\$2,500	\$3,000	\$3,000
Forestville Chamber	Membership match	\$700	\$700	\$700
Geyserville Chamber	Membership match	\$1,700	\$2,050	\$2,050
Mark West Chamber	Membership match	n/a	\$2,000	\$2,000
Monte Rio Chamber	Membership match	\$190	\$189	\$190
Russian River Chamber and Visitor Center	Membership match	\$4,000	\$6,500	\$6,000
Sebastopol Chamber and Visitors Center	Membership match	\$6,000	\$7,000	\$6,500
Sonoma Valley Chamber	Membership match	\$14,200	\$20,000	\$19,500
Total			\$41,439	\$39,940
Category A2 - Visitors Centers				Max: None
Cloverdale Visitors Center	Awarded in FY 15-16 for two consecutive FY.	\$10,000	\$10,000	\$10,000
Geyserville Visitors Center	1-year contract expires in June 2016.	\$5,000	\$19,000	\$6,500
Healdsburg Chamber & Visitors Center	Awarded in FY14-15 for three consecutive FY. 2nd year of contract	\$10,000	\$10,000	\$10,000
Petaluma	Awarded in FY14-15 for three consecutive FY. 2nd year of contract	\$10,000	\$10,000	\$10,000
Redwood Coast	Awarded in FY14-15 for three consecutive FY. 3rd year of contract	\$6,750	\$6,750	\$6,750
Russian River	Awarded in FY14-15 for three consecutive FY. 3rd year of contract	\$78,800	\$78,800	\$78,800
Santa Rosa	Awarded in FY14-15 for three consecutive FY. 3rd year of contract	\$31,000	\$31,000	\$31,000
Sebastopol	Awarded in FY14-15 for three consecutive FY. 3rd year of contract	\$13,350	\$13,350	\$13,350
Sonoma Coast (Bodega Bay)	Awarded in FY14-15 for three consecutive FY. 3rd year of contract	\$82,000	\$82,000	\$82,000
Sonoma Valley	Awarded in FY14-15 for three consecutive FY. 3rd year of contract	\$94,000	\$94,000	\$94,000
Total			\$354,900	\$342,400

FY 2016-17 Sonoma County Advertising Program Approved Grant Awards

Entity	Description of Funding Need	15-16 Advertising Grant	Amount Requested for 16-17	Approved Award
Category A3 - Economic Development				Max: None
Economic Development Department	Business Assistance Services	\$1,665,100	\$2,476,215	\$2,520,599
Sonoma County Lodging Association	Administrative staffing to provide advocacy and educational resources and increase marketing efforts.	\$35,000	\$35,000	\$35,000
Total			\$2,511,215	\$2,555,599
Category A4 - Tourism Marketing Program				Max: None
Sonoma County Tourism	Operations and Staffing	\$2,753,520	\$3,117,576	\$3,117,576
Total			\$3,117,576	\$3,117,576
Category A5 - Visitor Way Finding & Signage				Max \$100,000
Geyserville Chamber of Commerce	4 Welcome signs - south, north entrances on Geyserville Ave, as well as highway 128 entrance. One new sign for visitor center parking.	n/a	\$4,000	\$4,000
Healdsburg Performing Arts Theater, Inc. (DBA Raven Theater Windsor)	Restore historical marquee with unique neon design of Raven bird.	\$0	\$25,000	\$5,000
Museums of Sonoma County	Permanent signage along B Street for the new Art Museum and banners placed at the corner of B and 7th St.	\$20,000	\$10,000	\$10,000
Petaluma Visitors Program & Petaluma Arts Center	Permanent signage on utility poles in downtown Petaluma business district directing people to "Petaluma Visitors Program" and "Petaluma Arts Center".	n/a	\$28,837	\$10,000
Russian River Chamber of Commerce	Gateway Signage: 4 "Welcome To" signs: 116 South, from Hwy 1, and two "Welcome to Guerneville" signs in town and kiosk in downtown plaza, and lighting.	\$20,000	\$84,000	\$20,000
Sebastopol Center for the Arts	Permanent signage for Sebastopol Veterans Memorial Bldg to identify Sebastopol Center for the Arts in new location.	n/a	\$7,500	\$7,500
Sonoma Ecology Center	Internal way finding and internal signage in park.	\$9,550	\$11,500	\$10,000
Sonoma Valley Visitors Bureau	Sonoma Valley billboard program Hwy 37/121, official welcome sign to Sonoma County and Sonoma Valley.	\$20,000	\$20,700	\$20,500
Winegrowers of Dry Creek Valley	Replacement of 5 Welcome signs and major entrances to region, Dry Creek Rd, Westside Rd, Canyon Rd, Lytton Springs, and Dutcher.	n/a	\$15,000	\$10,000
Total			\$206,537	\$97,000

FY 2016-17 Sonoma County Advertising Program Approved Grant Awards

Entity	Description of Funding Need	15-16 Advertising Grant	Amount Requested for 16-17	Approved Award
Category A5 - Visitor Way Finding & Signage (ONE-TIME FUNDS)				
Sonoma County Fair & Exposition Center	Replacement of electronic sign at top of Grace Pavillion.	n/a	\$75,000	\$25,000
Total			\$75,000	\$25,000
Category A6 - Workforce Development and Scholarships				Max: \$400,000
10,000 Degrees	10,000 Degrees Sonoma County College Prep, Access & Success Expansion Program. Requesting \$300K/year for 5 years. Support for low-income Sonoma County students to attend and graduate from college. Includes funding for scholarships. Board approved funding of \$100K/year for 5 year term, ending in FY 2020-21. Board approved one-time funding of \$50,000 addition for FY 2016-17.	\$150,000	\$300,000	\$150,000
Career Technical Education Foundation - Ag and Food Career Exploration and Recruitment	Ag and Food Career Exploration and Recruitment administered by CTE Foundation in conjunction with Food Industry Group, Workforce Development Board, Santa Rosa Junior College, & Sonoma County Office of Education. Develop and promote career exploration and job placement opportunities in food and ag industry at high school and JC level.	n/a	\$25,000	\$0
Career Technical Education Foundation - Regional Advanced Mechanics Program	Regional Advanced Mechanics Program: Regional manufacturing training program to support local manufacturing needs for technicians and mechanics. Funding for program development, grants to high schools and SRJC for equipment, new course implementation, teacher externships and internship opportunities for students. Begins	\$50,000	\$50,000	\$50,000
Creative Sonoma Summer Arts Grants	Summer Arts Youth Grants	n/a	\$100,000	\$100,000
Creative Sonoma Arts Education Grants	Program to support equitable access arts education for underserved Sonoma County schools	n/a	n/a	\$24,000
Community Foundation: Arts Education Programs	Program to support equitable access arts education for underserved Sonoma County schools. Through collaboration with Creative Sonoma, funds will now be provided to Creative Sonoma to manage, with collaboration with the Community Foundation.	\$50,000	\$50,000	\$0
Community Foundation: Education/Mentorship	Career Technical Education: "New" courses at high schools and off campuses to develop local workforce in engineering/design or Advanced Tech & Manufacturing (STEM) county-wide. Year 4 of 5 year contract. FY 2013-14 through FY 2017-18.	\$51,000	\$51,000	\$51,000

FY 2016-17 Sonoma County Advertising Program Approved Grant Awards

Entity	Description of Funding Need	15-16 Advertising Grant	Amount Requested for 16-17	Approved Award
Santa Rosa Chamber of Commerce - Mike Hauser Algebra Academy	Algebra prep program and expansion for 8th & 9th graders in Sonoma County for whom English is a second language. 60% of enrolled students qualify as low income. Board approved funding of \$25,000/year for 3 year term, ending FY 2018-19.	\$35,000	\$35,000	\$25,000
		Total	\$611,000	\$400,000
Category B1 - Parks, Recreation and Event Facilities				Max: N/A
Regional Parks Department	Operations and Maintenance of existing facilities	\$2,331,431	\$2,751,507	\$2,651,507
General Services - Veteran's Buildings	Veteran's Building online marketing project	\$30,000	\$30,000	\$30,000
		Total	\$2,781,507	\$2,681,507
Category B1 - Parks, Recreation and Event Facilities (ONE-TIME FUNDS)				Max: N/A
Regional Parks Department - One-time Funds	Sonoma County Integrated Parks Plan (SCIPP) projects and 50th Anniversary Celebration	n/a	\$500,000	\$450,000
General Services - Veteran's Buildings - One-time Funds	Capital project improvements for Veteran's Buildings	n/a	\$684,403	\$400,000
		Total	\$1,184,403	\$850,000
Category B2 - Community Impacts - Public Safety				Max: \$90,000
Bodega Bay Fire Protection District	Safety training and education, utility vehicle for non-emergency and emergency response, AEDs.	\$35,000	\$90,000	\$15,000
Bodega Volunteer Fire Department	Station upgrades.	\$20,000	\$52,000	\$10,000
Cazadero Community Services District/Cazadero Volunteer Fire District	Exhaust system for Cazadero Fire Hall/Community Hall.	\$15,000	\$36,452	\$10,000
Monte Rio Fire Protection District	Maintain and improve Rescue Boat Program.	\$0	\$27,500	\$10,000
Occidental Fire Department	Auto Extrication Tool for motor vehicle related emergency response.	\$0	\$30,000	\$10,000
Russian River Chamber of Commerce & Visitors Center	Extension of contract with security firm to provide security services.	\$0	\$100,000	\$0

FY 2016-17 Sonoma County Advertising Program Approved Grant Awards

Entity	Description of Funding Need	15-16 Advertising Grant	Amount Requested for 16-17	Approved Award
Russian River FPD	CERT (Community Emergency Response Team) Program	\$0	\$15,000	\$0
Russian River FPD	Hydraulic rescue equipment, "Jaws of Life".	\$0	\$40,858	\$20,000
Timber Cove FPD	Rescue tool, Capstan, cylindrical shaft mounted on tailgate of rescue vehicle. Allows for faster and efficient rescue and increases safety for personnel.	\$0	\$12,904	\$5,000
Valley Moon FPD	Live fire structure for mandatory training.	\$20,000	\$70,000	\$10,000
Total			\$474,714	\$90,000
Category B2 - Community Impacts - Public Safety (ONE-TIME FUNDS)				Max: N/A
Fire and Emergency Services	Central Dispatch Costs for FY 16-17 - One Time Funding	n/a	\$768,000	\$768,000
Total			\$768,000	\$768,000
Category C - Agricultural Promotion				Max: \$185,000
Sonoma AgGregate/Sonoma County Vintners	SC Vintners, SC Winegrowers, SV Vintners & Growers, SC Farm Trails, SC Harvest Fair, Sonoma Wine Country Weekend, Wine Road	\$150,000	\$180,000	\$175,000
Wine Road – Northern Sonoma County Barrel	Barrel Tasting Weekends	\$5,000	\$5,000	\$3,000
Wine Road – Northern Sonoma County WINEland	Winter WINEland	\$5,000	\$5,000	\$3,000
Winegrowers of Dry Creek Valley - Passport	Passport to Dry Creek Valley	n/a	\$5,000	\$4,000
Total			\$195,000	\$185,000

FY 2016-17 Sonoma County Advertising Program Approved Grant Awards

Entity	Description of Funding Need	15-16 Advertising Grant	Amount Requested for 16-17	Approved Award
Category D - Historical Commissions				Max: \$50,000
Historical Records Commission	Peterson Prize an annual writing competition and general records preservation efforts	\$2,000	\$10,000	\$10,000
Landmarks Commission	Funding for preservation and restoration of historically significant buildings. Board approved \$10,000 additional funding, totaling \$50,000 for FY 2016-17.	\$28,000	\$60,000	\$50,000
Total			\$70,000	\$60,000
Category E - Local Events, Organizations and Economic Development				Max: \$160,000
District 1		\$41,440	\$43,229	\$43,229
District 2		\$16,056	\$16,096	\$16,096
District 3		\$18,368	\$18,340	\$18,340
District 4		\$29,072	\$29,603	\$29,603
District 5		\$55,064	\$52,732	\$52,732
Total			\$160,000	\$160,000
Category F - Local Events, Organizations and Economic Development				Max: \$300,000
American Legion Post 28	Petaluma Veterans Day Parade	n/a	\$11,000	\$4,000
Cruisin the Boulevard	Petaluma's Salute to American Graffiti	n/a	\$10,000	\$4,000
Luther Burbank Rose Parade & Festival	123 Annual Rose Parade and Festival	\$6,000	\$7,000	\$5,000
Sonoma County Farm Trails	Gravenstein Apple Fair	\$15,000	\$15,000	\$13,000
Sonoma Volunteer Firefighter Association	44th Annual July 4th Fireworks Show in Sonoma	n/a	\$10,000	\$3,000
Charles M. Schulz Museum and Research Center	General marketing program for Sept-Dec. 2016	n/a	\$12,700	\$5,000
Green Music Center at Sonoma State University	2016-17 Winter/Spring Season	n/a	\$50,000	\$17,500
Jack London Park Partners	2016 Jack London Centennial Celebration	n/a	\$35,000	\$8,500
Pacific Coast Air Museum	2 events: 1. Airshow 2016 presented by the Pacific Coast Air Museum (formerly Wings Over Wine Country), 2. Pacific Coast Air Museum event series (Climb Aboards and Special Events, Aviation Summer School, 9/11 Commemoration, Veteran's Day, Santa Fly-In)	\$20,000	\$25,000	\$10,000
Sonoma County Fair	2016 Sonoma County Fair	\$40,000	\$50,000	\$40,000

FY 2016-17 Sonoma County Advertising Program Approved Grant Awards

Entity	Description of Funding Need	15-16 Advertising Grant	Amount Requested for 16-17	Approved Award
Summer Repertory Theatre Festival	5 events: Gershwin's Nice Work if You Can Get It; Rock of Ages; Merrily We Roll Along; Boeing Boeing; The Little Dog Laughed	n/a	\$15,000	\$5,000
6th Street Playhouse	2016-17 6th Street Playhouse season	n/a	\$50,000	\$10,000
Healdsburg Jazz Festival, Inc.	2016-17 Healdsburg Jazz year round programming	\$12,000	\$45,000	\$10,000
Luther Burbank Memorial Foundation	Wells Fargo Center for the Arts 2016-17 Season	\$50,000	\$50,000	\$45,000
Museums of Sonoma County	Art and History Museum year round exhibition programs	\$43,000	\$50,000	\$40,000
Petaluma Downtown Association -	4 events: Butter & Egg Days Parade, 2 Antique Fairs, and The Art & Garden Festival	\$5,000	\$18,000	\$5,000
Santa Rosa Symphony	89th Season - year round concerts series, special events and integrated community	\$50,000	\$50,000	\$50,000
Sebastopol Center for the Arts	Year round art exhibitions, classes, musical performances, poetry events, special	\$40,000	\$50,000	\$25,000
Total			\$553,700	\$300,000
Category G1 - Department Activities				Max: None
Sonoma County Library	Digital Image Collection	\$33,350	\$40,000	\$25,000
Agricultural Commissioner	2017 CA State Fair Exhibit	\$14,000	\$20,000	\$20,000
Total			\$60,000	\$45,000
Category G1 - Department Activities (ONE-TIME FUNDS)				Max: None
CDC Department	Roseland Mural Project	n/a	\$71,000	\$12,000
Health Services Department	Russian River Monitoring	n/a	\$80,000	\$40,000
Sonoma County Fair Foundation	Saralee and Richard's Barn	\$200,000	\$75,000	\$75,000
Total			\$226,000	\$127,000

FY 2016-17 Sonoma County Advertising Program Approved Grant Awards

Entity	Description of Funding Need	15-16 Advertising Grant	Amount Requested for 16-17	Approved Award
Category G2 - Affordable Housing				
				Max: N/A
Set Aside Fund for Emergency Shelter	Maintain in Advertising Fund	\$60,000	\$60,000	\$60,000
Community Development Commission	Homeless Services	\$220,000	\$285,000	\$285,000
Permit and Resource Management	Housing Element Implementation	\$100,000	\$150,000	\$150,000
		Total	\$495,000	\$495,000
Category G2 - Affordable Housing (ONE-TIME)				
				Max: N/A
Workforce Housing Public-Private Partnership	Funds reserved under County Fund for Housing, administered through CDC.	\$0	\$1,000,000	\$1,000,000
		Total	\$1,000,000	\$1,000,000
Category G3 - Collections/Audit Services				
				Max: N/A
ACTTC - Collections	Tax collection administration activities	\$367,819	\$367,819	\$367,819
ACTTC - Audit	Audit services including program grant audits, collection audits and VRBO	\$99,850	\$99,850	\$99,850
		Total	\$467,669	\$467,669
Category G4 - Legal Services				
				Max: N/A
County Counsel	Program and collections legal services	\$41,810	\$51,810	\$51,810
		Total	\$51,810	\$51,810
Category G5 - Program Administration				
				Max: N/A
CAO/BOS	Program staff support	\$380,000	\$432,093	\$432,093
PRMD	Code Enforcement Vacation Rental Services	\$150,000	\$150,000	\$150,000
PRMD	Code Enforcement Vacation Rental Services - Night/Weekend	\$95,940	\$95,940	\$95,940
EFS Administration costs		\$1,787	\$1,787	\$1,787
		Total	\$679,820	\$679,820

FY 2016-17 Sonoma County Advertising Program Approved Grant Awards

Entity	Description of Funding Need	15-16 Advertising Grant	Amount Requested for 16-17	Approved Award
Category H - Documentary Films				Max: \$30,000
KRCB North Bay Public Media	Short documentaries that promote "rural art" in Sonoma County.	\$0	\$10,000	\$10,000
Museums of Sonoma County	Short documentary on Sonoma County artist Ned Kahn, creator of prominent kinetic sculpture titled "erratic fence".	\$0	\$10,000	\$7,500
*KRCB - Sonoma County Human Rights Commission	NorthBay DREAMers Documentary Film and Social Media Project.	\$0	\$5,000	\$7,500
Winegrowers of Dry Creek Valley	Oral Histories project documenting the history and evolution of the Dry Creek Valley wine region.	n/a	\$10,000	\$5,000
Total			\$35,000	\$30,000
Category I - Seasonal and Off Peak Programs				Max: \$50,000
Alexander Valley Film Society	Alexander Valley Film Festival	\$5,000	\$5,000	\$3,000
Courtney's Pumpkin Patch	Event on 10/1/16.	n/a	\$1,000	\$0
Duncans Mills Association	This organization is not a non-profit	n/a	\$5,000	\$0
Geyserville Chamber of Commerce	3 events: May Day, Fall Colors, Tractor Parade	n/a	\$11,300	\$5,000
King Ridge Foundation (formerly VeloStreet, Inc.)	Levi's GranFondo	n/a	\$50,000	\$5,000
Kut Ups of Rohnert Park	Summer Main Stage Shows	\$1,400	\$2,000	\$0

FY 2016-17 Sonoma County Advertising Program Approved Grant Awards

Entity	Description of Funding Need	15-16 Advertising Grant	Amount Requested for 16-17	Approved Award
Performing Arts Coalition for Theater, Inc (dba Main Stage West)	End of 2016 season, first half of 2017 season	n/a	\$5,000	\$4,000
Sebastopol Center for the Arts	Sonoma County Art Trails	\$10,000	\$10,000	\$5,000
Sebastopol Chamber (Apple Blossom Festival and Parade)	71st Apple Blossom Festival and Parade	\$5,000	\$5,000	\$5,000
Sonoma International Film Festival	Sonoma International Film Festival (5 days)	\$12,000	\$17,000	\$5,000
Sonoma County Farm Trails	Holidays Along the Farm Trails	n/a	\$5,000	\$4,000
Sonoma Valley Visitors Bureau	4 events: Holidays in Sonoma Valley, Sonoma Valley Olive Season, Romance in Sonoma Valley, Sonoma Valley Girlfriends and Guys Getaways	\$8,000	\$50,000	\$5,000
Total			\$166,300	\$41,000
Reserves				
Allocate to Economic Uncertainty				\$300,000
Allocate to Contingencies				\$89,676
Total				\$389,676
Total Expenditures				\$15,008,997
Revenues				
TOT Collections				\$10,628,100
Interest on pooled cash				\$25,000
Available Fund Balance				\$4,388,907
Total				\$15,042,007
Total Revenues				\$15,042,007

Description	Amount
CALLE	
CALLE Task Force stipend, training/travel, & program	\$111,600
Extend CALLE Task Force support through June 30, 2015	\$39,830
TOTAL	\$151,430
Department Support	
County Counsel salary equity adjustments	\$134,100
Animal Care & Control support for FY 2013-14 staffing	\$7,500
Agricultural Commissioner's Office Re-organization - Chief Environmental Engineer	\$52,000
Health-Animal Care: partial year increased staffing cost	\$35,145
Agricultural Commissioner partial year increased staff to provide land sustainability engineering	\$52,000
General Services Director position succession staffing costs	\$50,000
2nd Q Consolidated Budget Adjustment	\$128,000
County Counsel fees for Winery Events Study Session Report	\$68,272
County Counsel (CBA)	\$10,000
Janitorial Services Living Wage Ordinance implementation (CBA)	\$97,532
District Attorney CBA for 1.0 FTE Legal Assistant and 1.0 FTE Legal Secretary to support increased workload associated with use of Body Worn Camera video in review of cases and preparation for trial, including transcription of audio components	\$148,302
Public Defender to fund 1.0 FTE Deputy Public Defender IV to provide criminal legal services in an additional misdemeanor courtroom, which was established by the Sonoma County Superior Court to meet increased misdemeanor caseload demand	\$145,017
Health Services one-time to finance an Environmental Health Program Manager to support cannabis ordinance development and related work	\$152,760
Misc Classification Changes & Budget Adjustments (Fleet Operations)	\$4,903
Blue Green Algae	\$35,884
District Attorney Time Limited Legal Processor II Positions	\$116,824
Consolidate Behavioral Health Services	\$1,006,338
Funds to add one aide to each district to align with comparable counties' staffing levels	\$165,500
TOTAL	\$2,410,077
Disaster Response & Recovery	
Disaster Response and Recovery Fund Contribution	\$1,900,000
TOTAL	\$1,900,000
Election Costs	
Registrar of Voters June 2015 election costs	\$530,000
Regional Parks Special Transactions and Use Tax Ordinance ballot measure costs	\$280,000
PRMD Community Separators Protection Ordinance ballot measure costs	\$279,585
Cannabis ballot measure	\$400,000
TOTAL	\$1,489,585

Facilities

Re-budget prior year transfer to Central Mechanical Plant capital project	\$94,695
Veterans Memorial Buildings	\$70,391
Chanate Property Repurposing	\$100,000
General Services contract with First Alarm & Professional Event Security for security patrols	\$75,336
County parking lot sweeping for NPDES compliance	\$82,810
Operating cost for returning mgt of Vets Bldgs to General Svcs Dpt	\$55,180
TOTAL	\$478,412

Groundwater

Santa Rosa Plan Underground Study	\$20,000
TOTAL	\$20,000

Infrastructure

Arnold Drive Bike Lane Feasibility Study	\$50,000
Quiet Zones at Railroad Crossings	\$800,000
TOTAL	\$850,000

Legal

Outside Counsel and Technical Consultant	\$87,500
Legal Services Agreement & In-House Support for Sonoma Complex Fires PG&E Litigation	\$17,046
TOTAL	\$104,546

Outside Agency Support

Resource Conservation Districts county-wide land conservation aid and education	\$160,000
Sheriff Chaplaincy 3-year agreement	\$24,200
Preschool Facilities Grant Program	\$305,000
Palms Inn Single Room Occupancy Units	\$200,000
Agreement with Sonoma County Public Law Library	\$40,000
Resource Conservation District 2-Year Memorandum of Understanding Agreement	\$250,000
United Way Earn It-Keep It-Save It Contract	\$200,000
Volunteer Fire Companies Operations Funding	\$100,000
Ceres Project Medi-Cal Project Equipment Funding	\$35,000
Dispatch Services	\$850,000
Law Enforcement Chaplaincy Program	\$25,000
Legal Aid	\$180,000
TOTAL	\$2,369,200

Parks

Regional Park Planning and Maintenance	\$40,000
Sonoma County Integrated Parks Plan	\$28,177
Name change of fields at Ragle Ranch to Rudy Theirller Memorial Athletic Fields	\$2,500
Andy's Unity Park - Construction Re-Bid Aware and Direction on Funding Gap	\$698,559
TOTAL	\$769,236

Permit Sonoma (PRMD) Work

Community Separator Work Plan	\$57,250
TOTAL	\$57,250

Senior	
IHSS Public Authority / SEIU Local 2015 MOU	\$204,137
Aging Together Initiative	\$10,000
Senior Homeless Prevention Program	\$37,500
Senior Meals Contract	\$238,850
TOTAL	\$490,487

Sponsorships	
Sebastopol Center for the Arts for the AARP Tax-Aide Program Sebastopol Veteran's Memorial Building	\$4,525
Russian River Sister's free Christmas dinner at the Guerneville Veteran's Memorial Building	\$760
Operation Access medical volunteers event "Healthy Spirits - A Celebration of Operation Access Medical Volunteers"	\$2,500
Contribution to Leadership Institute for Ecology and the Economy's workshop: A Call to Advance Social Equity Workshop	\$1,000
Sponsorship Deputy Sheriff Deeds Memorial Highway Sinage	\$35,000
Art Ibleto's Pasta King Fundraiser for Nepal	\$1,770
Sponsorship of the 2016 Latino State of the County Event	\$8,000
Sponsorship of the 17th Annual Tribute to Veterans	\$500
Sponsorship of Latino State of the County Event	\$8,000
Petaluma Education Foundation Fee Waiver	\$5,198
Sebastopol Veteran's Memorial Building for the AARP Tax-Aide Program	\$4,625
Sebastopol Center for the Arts for Redwood Empire Food Bank	\$2,740
TOTAL	\$74,618

Upstream Investments	
Program Planning and Evaluation Analyst for Upstream Investments technical assistance	\$82,970
TOTAL	\$82,970

Veterans Services	
Senior OA for Veterans Service Office	\$50,163
TOTAL	\$50,163

Veterans/Students Services	
Subsidized Transit Fare Program for College Students & Veterans (partial year)	\$155,500
Subsidized Transit Program	\$115,000
Transit Fare Program for Veterans & College Students	\$123,916
Subsidized Transit Fare Program for Veterans & College Students	\$73,021
TOTAL	\$467,437

Fee Waivers

Bodega Volunteer Fire Dept.'s Big Event	\$1,864
National Night Out Farm Watch Parade	\$136
Community and Family Service Agency's community meals program and annual Thanksgiving free meal at the Guerneville Veteran's Building during FY 14-15	\$4,763
Slow Food Russian River to operate a community apple press at Luther Burbank Experiment Farm	\$2,500
Building permit and driveway inspection fees for Sonoma County Horse Council for the improvements to the equestrian parking lot at Bodega Head on Bayflat Road	\$573
Historic Rio Nido sign project	\$1,142
Building permit fees for the Rancho Adobe Fire District incurred in the replacement of HVAC	\$156
Fee Waivers	\$19,919
Forestville Youth Park BBQ - Fee Waiver	\$4,347
Boys & Girls Club Probation Fee Waiver for Fingerprinting	\$2,000
Bodega Bay Fire Dept. 4th July Fireworks Regional Parks Permit Fee	\$1,143
Cloverdale Food Pantry Xmas in June - Building Fee Waiver	\$1,085
Occidental Center for the Arts - Fee Waiver Use Permit Modification	\$1,247
Council on Aging - Fee Waiver for Health Inspection Fees	\$8,369
Health Inspection Fees for Sonoma Home Meals	\$914
Kenwood July 4th Hometown Parade Fee Waiver	\$586
Blood Centers Sonoma Veterans Building Fee Waiver	\$3,950
Occidental Center for the Arts Use Permit	\$2,426
Monte Rio Russian River Car Show	\$1,645
Bodega Volunteer Fire Big Event	\$1,864
Day Use Parking Fees for Sea Ranch	\$10,000
Rent Reduction for the Kindergym Program	\$4,885
Regional Parks Day Use Fee Waiver to Honor Veterans	\$3,500
Russian River Car Show	\$1,923
Bodega Volunteer Fire Dept.'s Big Event	\$2,007
Redwood Empire Food Bank Veterans Building Fee Waiver	\$9,430
Regional Parks Day Use Fee Waiver for Veterans	\$2,100
West County Community Services, Free Dinners Program	\$1,789
Penngrove Holiday Parade of Lights	\$821
West County Community Services Thanksgiving Event	\$501
Russian River Sisters of Perpetual Indulgence Free Community Christmas Dinner	\$619
Veterans of Foreign Wars Black History Program	\$538
Veterans of Foreign Wars Shelter Thank You Event	\$151
Hwy 101 Forum at Petaluma Veterans Building	\$491
Forestville Youth Park Fundraiser	\$4,636
Occidental Center for the Arts Fool's Day Parade	\$847
Redwood Empire Food Bank Guerneville Veterans Building Fee Waiver	\$2,400
Redwood Empire Food Bank Santa Rosa Veterans Building Fee Waiver	\$2,310
Rotary Club of Rohnert Park-Cotati for Veterans Appreciation	\$1,076
Health Inspection Fees for Sonoma Home Meals	\$984
TOTAL	\$111,637

Youth Services

Youth Ecology Corps and Fire Mt. Pilot	\$102,500
TOTAL	\$102,500

Total For Fiscal Years FY 2014-15, 2015-16, 2016-17, and 2017-18	\$11,979,548
---	---------------------

<i>Annual Average</i>	<i>\$2,994,887</i>
-----------------------	--------------------

 <p style="text-align: center;">County of Sonoma Agenda Item Summary Report</p> <p>Clerk of the Board 575 Administration Drive Santa Rosa, CA 95403</p>	<p>Agenda Item Number: (This Section for use by Clerk of the Board Only.)</p>
<p>To: Board of Supervisors</p>	
<p>Board Agenda Date: October 3, 2017</p>	<p>Vote Requirement: Majority</p>
<p>Department or Agency Name(s): County Administrator's Office</p>	
<p>Staff Name and Phone Number: Sheryl Bratton 707-565-2431</p>	<p>Supervisorial District(s): All</p>
<p>Title: Measure L Ad Hoc Recommendations</p>	
<p>Recommended Actions:</p>	
<p>Approve final recommendations of the Measure L Ad Hoc Committee on Transient Occupancy Tax (TOT) policies, including areas of community investment with TOT revenue;</p> <p>Adopt a Resolution to authorize the necessary budgetary adjustments for two positions within the Auditor-Controller Treasurer-Tax Collector's Office to ensure the County collects all TOT revenue that is due and provides the public with accountability;</p> <p>Approve an Agreement between the Economic Development Board and the Sonoma County Tourism Bureau for services and programs promoting tourism in Sonoma County funded by assessments from within the Sonoma County Tourism Business Improvement Area (BIA); and</p> <p>Delegate authority to the County Administrator to execute an Agreement between the County of Sonoma and the Sonoma County Tourism Bureau for services and programs promoting tourism in Sonoma County funded by a portion of Transient Occupancy Tax (TOT) revenue.</p>	
<p>Executive Summary:</p>	
<p>The Measure L Ad Hoc Committee (Ad Hoc) has met since March, 2017. The Board of Supervisors approved the Ad Hoc Charter in April, 2017. The Ad Hoc Charter defined the scope of the Committee as including a holistic review of TOT investments and policies, including the new additional revenue generated through Measure L.</p> <p>The Ad Hoc held a study session in June, 2017 to receive input from Supervisors and the public. This agenda item provides Ad Hoc recommendations for amendments to the County's Advertising and Promotions Program Policy, including recommendations for allocating the new revenue generated from the Measure L Transient Occupancy Tax increase of 3%, and reflects input received from the Supervisors</p>	

during the June study session. The specific recommendations are detailed in this agenda item and its attachments.

Discussion:

On January 10, 2017, the Board created the Measure L Ad Hoc Committee comprised of Supervisors Zane and Hopkins. The Measure L Ad Hoc has met since March to develop recommendations to guide allocation of revenue from the recently adopted Transient Occupancy Tax increase, Measure L, as well as develop a County Sponsorship Policy. On April 11, 2017, the Board of Supervisors approved the Measure L Ad Hoc Committee Charter (Attachment A).

On June 13, 2017, the Board of Supervisors held a study session for the Measure L Ad Hoc to present several baseline recommendations and to solicit Board and community input to help guide further recommendations. In developing recommendations, the Measure L Ad Hoc established three key principles to guide TOT spending:

- Principle 1: Transient Occupancy Tax revenue should be used to mitigate the impacts of tourism, and support Board Strategic Priorities.
- Principle 2: Transient Occupancy Tax revenue should be used to enhance the local economy.
- Principle 3: The County will meet the commitments made during the Measure L campaign, emphasizing the funding of specific areas noted in the ballot measure.

Following the study session, the Ad Hoc has met to develop recommendations for amendments to the County’s Advertising and Promotions Program Policy, including recommendations for allocating the new revenue generated from the Measure L Transient Occupancy Tax increase of 3%.

Final Measure L Ad Hoc Committee Recommendations

During the June study session, the Board provided support to adopt the Ad Hoc’s recommendation of renaming the Advertising and Promotions Program to the Community Investment Program and to streamline the Policy. The Ad Hoc recommends the Board adopt this new program title and is presenting the following policy revisions for the Board’s consideration. The original policy (Attachment B) and full revised policy (Attachment C) are provided. While the recommendations provide a streamlined approach to investing TOT revenue, all current recipients of “Advertising Grants” will continue to be eligible to apply for future grants. In addition, the revised policy, if approved by the Board, would become effective in the following fiscal year. Current year funding decisions are not impacted by these recommended changes. A “crosswalk” between the old and revised policy is attached (Attachment D).

Rename the Program and Reorganize the Program Policy

As discussed during the June study session, the Measure L Ad Hoc Committee recommends renaming the “Advertising and Promotions Program” to the “Community Investment Program” to better demonstrate where existing TOT and Measure L funds are spent. In FY 16-17, \$4.2 million, or 28% was spent on advertising activities to promote Sonoma County as a tourist destination. The remaining, \$11 million, or 72%, was allocated to support community needs, such as for parks, fire services, housing, homeless services, economic development activities, and Veteran’s Hall improvements, as well as for program administration.

The Ad Hoc also recommends reorganizing the Policy. The current Advertising Program Policy is complex and difficult to understand from the perspective of the general public. There are numerous categories, and complexity in what criteria apply to funding decisions within categories. The Ad Hoc recommends establishing four overarching categories within the Policy for the 9%: Economic and Workforce Development; Community Services and Safety; Community Non-Profit Grants; and Program Integrity and Administration.

General Fund Contribution

Sonoma County is an extreme outlier amongst neighboring and comparable counties in the minimal amount of TOT invested into the General Fund. These counties invest virtually all or a significant majority of TOT revenue into the General Fund. Sonoma County currently invests only 25%. Information about how other counties apportion TOT revenue is attached (Attachment E). The Ad Hoc is recommending to increase the General Fund split of the first 9% of TOT, from 25% to 33% in order to pay for miscellaneous funding currently paid out of TOT.

The Ad Hoc's recommendations focus on direct community investments and moves approximately \$1.1 million of miscellaneous funding areas out of the recommended policy. The funding areas to be moved outside the policy include:

- 1.0 FTE in the Permit and Resource Management Department for Housing Element Implementation (Allocation of \$150,000 in Fiscal Year 2017-18).
- 4.75 FTE for County Administrator Office and Board of Supervisor staff positions that provide program support (Allocation of \$576,068 in Fiscal Year 2017-18).
- 1.0 FTE in the Permit and Resource Management Department for Code Enforcement of Vacation Rental Services (Allocation of \$150,000 in Fiscal Year 2017-18).
- \$225,000 for the Community Development Commission to fund Jones Hall (\$165,000) and Emergency Shelter Set-Aside (\$60,000).

In order to move the miscellaneous funds out of the policy, the Ad Hoc recommends increasing the contribution of TOT to the General Fund needs to be increased from 25% to 33% which will provide funding for the \$1.1 million of miscellaneous funding described above. The increased share of the General Fund is not expected to take away any existing TOT funding from other programs. In addition, the 33% contribution will only apply to the first 9% of TOT collected. No general fund contribution will be taken out of the additional 3% of TOT collected based on the Measure L increase. All Measure L funding will be invested directly in programs per the Board's direction and approved Ad Hoc recommendations.

Program Areas

The Community Investment Program Policy contains a reorganized approach to many of the funding commitments included in the former Advertising and Promotions Program Policy to better demonstrate the beneficial impact that these investments have on non-profits in the community, mitigation of tourist impacts, and promotion of the County's assets. The numerous categories that existed under the "Advertising Program", have been reorganized into four overarching categories, applicable to the first 9% of TOT funds: Economic and Workforce Development; Community Services and Safety; Community Non-Profit Grants; and Program Integrity and Administration.

Within the new category of Economic and Workforce Development, the County will fund Chambers of Commerce, Visitors Centers, the Economic Development Board, Tourism Marketing Program, Visitor and Way Finding Signage, and Workforce Development Scholarships. The Ad Hoc is making recommendations related to changes in funding for the Chambers of Commerce, the Tourism Marketing Program, and to Workforce Development Scholarships.

The Ad Hoc recommends revising the policy for Chambers of Commerce to further prioritize chambers serving the unincorporated area of the county and those serving the entire county. Only after these Chambers are fully funded based upon the existing policy of 10% match of membership dues and private cash contributions, will the County consider requests from Chambers located in incorporated areas. The maximum of \$40,000 per year is unchanged from the prior policy.

Within the category area of Economic and Workforce Development, the Ad Hoc recommends increasing the maximum allowable investment in Workforce Development and Scholarships from the current \$400,000 to a recommended \$500,000. This recommendation is based on a recognition that a qualified workforce is essential to the growing needs of the tourism industry as well as the overall health of the community. Requests may be made annually for multi-year grants, which is unchanged from the prior policy.

The Ad Hoc is making recommendations related to the funding and service deliverables of the Sonoma County Tourism Bureau (Tourism Bureau), which constitute the County's Tourism Marketing Program. The recommended draft contract is provided (Attachment F). Commencing with Fiscal Year 2018-19, the County's TOT contribution to SCTB will be a sum equivalent of the first 1.25% of the 9% of TOT collected in the unincorporated Sonoma County. The county's TOT contribution is disbursed through the EDB budget.

The substantive changes in the contract include:

- Funding for the Tourism Bureau for fiscal year 2017-18 will be \$3,117,576, with a reduction in funding starting in 2018-19 to a sum equivalent of 1.25% of the 9% of TOT collected. The Measure L Ad Hoc developed this recommendation after reviewing staffing levels and the amount of funds received by the Tourism Bureau from 2008-2016 (Attachment G) from both the Business Improvement Assessment (BIA) and from TOT. The Measure L Ad Hoc also reviewed funding and staffing levels of tourism bureaus in comparable California counties (Attachment H). Upon analysis, the Ad Hoc found that the Tourism Bureau receives significantly more TOT than similar tourism organizations in other jurisdictions. In conducting this analysis, staff researched reports and other information regarding funding of tourism promotion activities. While a study conducted by a tourism industry association concludes taking all funding away from tourism promotion has a negative impact on tourism activity, the Tourism Bureau would continue to receive over \$2 million in TOT in addition to Business Improvement Assessment revenue, which is the primary revenue source for tourism organizations in other jurisdictions.

The reduction in funding to the Tourism Bureau will allow the Board to re-direct a portion of the funding towards the establishment of an efficient, effective and sustainable fire services delivery model. The Board's Fire Services Ad Hoc is scheduled to come back to the Board later this year with a proposed plan for the full Board to consider.

- The Tourism Bureau will expend \$100,000 over two years (2017-18, 2018-19) to secure state-wide or regional conference(s), such as California Forward’s annual economic summit, that highlights Sonoma County and the collective work the community undertakes to improve the quality of life of residents and visitors. Specific opportunities will be pursued in partnership with the Sonoma County Administrator’s Office.
- In addition to the independent audit required by the contract, the Tourism Bureau will hire a separate independent auditor in 2017 to conduct a financial audit, including revenue sources, expenditures and travel and meal reimbursements. The County will produce a list of three qualified firms, from which the Contractor may select one. Contractor will use up to \$50,000 of the revenue received under this agreement to pay for the audit. Work will be initiated by December 31, 2018. The auditor will have complete access to the Tourism Bureau’s financial records. Audit findings will be provided to the Contractor for review and comment prior to becoming final. The final report will be delivered to the County Administrator’s Office concurrently with the Contractor’s President/CEO.
- The Tourism Bureau will spend a minimum of \$250,000 in 2017-18, and a minimum of \$100,000 in 2018-19 to enhance safety (e.g. lighted and/or marked crosswalks), environmental clean-up (e.g. removing trash from beaches and waterways), promote hospitality professionalization, and improve way-finding signage, (e.g. park locations and cultural sites). Specific projects will be located in areas that have high-tourist visits. The Tourism Bureau will report to the Board of Supervisors how funds were dispersed during the Tourism Bureau’s annual reporting process.
- The Tourism Bureau will provide an annual report on investments made and outcomes achieved to the County Administrator and Board of Supervisors.

Community Non-Profit Grants

Grants made to community non-profits include several Ad Hoc recommended changes.

The first recommendation, under the Agricultural Promotion section, is to expand from promotion of viticulture exclusively, to include diverse agricultural promotion. Effective for the 2018-19 grant cycle, any non-profits promoting agriculture in Sonoma County will be able to apply for funds through the County Administrator’s Office. This change eliminates the requirement to have only one single application submitted and opens up grant opportunities to any qualifying entity to apply.

The second recommendation, related to Local Events, Organizations, and Economic Development provided at the discretion of each Supervisorial District, opens this category for general activities that support community organizations, in addition to funds provided for advertising and economic development. Currently funding is limited to advertising and economic development only.

A third recommendation, effective in Fiscal year 2018-19 is the elimination of Community Safety grants (formerly known as “Category B2” grants) in the total amount of \$90,000 and redirecting funds towards the needs identified by the Board to support the Fire Services Project to establish an efficient, effective and sustainable fire services delivery model. This recommendation does not reduce the amount of

support provided to community safety, rather consolidates this funding with other Fire Services funding via TOT.

A final Ad Hoc recommendation includes requiring non-profit entities to include details of any other funding support they are seeking from other local organizations or local government entities so that the County has more complete information about potential funding sources.

Program Integrity and Administration

Ensuring the County collects all TOT revenue that is due and provides the public with accountability of collecting and investment in the program areas is essential. Because of this, the Ad Hoc recommends investing in staffing and other costs related to the collection, audit, program coordination, consultant, and legal services related to TOT. Request for Advertising funds from applicable departments will be reviewed annually on a case-by-case basis. The previous category of the Advertising and Promotions Policy allowing for “Miscellaneous Department Activities” has been deleted to only allow designated departments to apply for Program Integrity and Administration funding. Designated departments include Auditor-Controller Treasurer-Tax Collector, County Administrator/Board of Supervisors, County Counsel, and Permit and Resource Management.

Measure L Revenue

The Ad Hoc continues its recommendations from the Board’s study session in June for investment of Measure L revenue. The County will track and distribute the 3% “Measure L increase” to TOT separately from the first 9% collected. The categories established for Measure L funding distribution are based on the educational information provided to voters as part of the Measure L campaign, and are detailed below. Amendments to these funding commitments will be considered at the discretion of the Board of Supervisors.

- **Roads Repair and Improvement** will receive 20% to mitigate the impact of increased vehicles on roads in the unincorporated area of Sonoma County. For Fiscal Year 2017-18, this equates to an allocation of \$1 million. Direction was given by the Board during the June study session to pursue this recommendation and final direction was given during Budget Hearings in June, 2017. This revenue will be allocated to Transportation and Public Works (TPW) for improvements to local roads. Funding will support projects that support the annual TPW Roads Plan. These funds are in addition to the following amounts recently dedicated by the Board of Supervisors:
 - \$11.9 million annually in paving.
 - \$5.4 million annually for road maintenance.
 - \$4.1 million to address unfunded costs for roads impacted by winter storms in Fiscal Year 2017-18, which includes \$3.11 million dedicated to Transportation and Public Works during Fiscal Year 2017-18 budget hearings and an additional \$995,000 to be appropriated during Quarter 1 Consolidated Budget Adjustments.

The State of California existing gas tax will also contribute approximately \$11.4 million to road maintenance of Sonoma County’s 1,380 miles of roads. In addition, \$3.8 million of State funding will be provided in 2017-18 resulting from Senate Bill 1 fund split for pavement and roads maintenance. Senate Bill 1 funding will raise Sonoma County’s total state allocation to about \$23 million annually when the bill is fully implemented.

In addition, local Measure M funds provide approximately \$2 million of local sales tax funds annually for road maintenance.

- **Regional Parks** will receive 20% effective for Fiscal Year 2017-18 and Fiscal Year 2018-19. For Fiscal Year 2017-18, this equates to an allocation of \$1 million. Funding in this area for the Regional Parks Department will be prioritized to increase public access and support the development of new park facilities. Direction was given by the Board during the June study session to pursue this recommendation and final direction was given during Budget Hearings in June, 2017.

In addition to the Measure L funding, Regional Parks received \$2.65 million in TOT funds from the initial 9% of TOT to support ongoing operations and maintenance and \$4.74 million in General Fund to support other essential needs.

- **Fire Services** will receive 20% to provide for the safety and emergency care of residents and visitors. For Fiscal Year 2017-18, this equates to an allocation of \$1 million. Direction was given by the Board during the June study session to pursue this recommendation of directing Measure L funding towards Fire Services and final direction was given during Budget Hearings in June, 2017. The tourism industry, while beneficial for the health and economy of the county, can strain the agencies responsible for emergency response. To help alleviate this strain and to encourage greater regional consolidation within the county's fire system, funds will be available to support the Board's approval of a plan to establish an efficient, effective and sustainable fire services delivery model. The Board's Fire Services Ad Hoc will bring a recommendations back to the Board in the coming months for the Board to consider. The Board of Supervisors will prioritize recommendations that further regional consolidation, provide equipment and personnel support in high-risk areas, and provide increased response coverage in underserved/high risk areas of the county.

In addition to Measure L TOT funds, the County has also budgeted \$1.33 million in Prop. 172 funding for Fire Services as well as \$90,000 from the larger TOT fund for Community Safety grants (formerly known as "Category B2" grants) in Fiscal Year 2017-18. As discussed earlier in this item, the reduction in funding to the Tourism Bureau in Fiscal Year 2017-18 will allow the Board to re-direct a portion of the funding towards the establishment of an efficient, effective and sustainable fire services delivery model. The Board's Fire Services Ad Hoc is scheduled to come back to the Board later this year with a proposed plan for the full Board to consider.

- **Affordable Housing** will receive 13% of Measure L funds to support the County's efforts to increase housing through affordable and workforce housing partnerships, housing and rent stabilization, and homeless services. Direction was given by the Board during the June study session to pursue this recommendation and final direction was given during Budget Hearings in June, 2017. For Fiscal Year 2017-18, this equates to an allocation of \$621,000. Funds shall be allocated to the existing County Fund for Housing as well as to homeless service needs, administrated by the Community Development Commission. The Ad Hoc recommends this allocation specifically fund Coordinated Intake HUD Mandate of Continuum of Care (\$40,000)

and Homeless Count (\$80,000) and the remaining funds (\$501,000) be contributed to the County Fund for Housing for Fiscal Year 2017-18.

In addition to the Measure L funds, the Board of Supervisors, primarily through the Community Development Commission, has also dedicated \$5.7 million towards homeless service needs and has made \$4 million available through the County Fund for Housing. If approved, the additional \$501,000 of Measure L dollars will help fund additional project awards to be selected and approved by the Board in November, 2017.

- **Code Enforcement and Operator Compliance** will receive 8% of Measure L funds (approximately \$385,000 for Fiscal Year 2017-18) to enhance administration of the Community Investment Program (formerly Advertising Program). This investment will provide for revenue and tax collection services and program and grantee audit services as well as code enforcement and operator compliance related activities.

The Ad Hoc recommends investment of \$385,000 of Measure L funds in the following needs:

- \$218,000 for 2.0 FTE in the Auditor-Controller-Treasurer-Tax Collector (ACTTC) office is to improve the amount of TOT collected. The associated Exhibit and Budget and Position Resolution are included (Attachment G).
- \$30,000 for PRMD night/weekend Code Enforcement (services to be provided through a contracted entity).
- \$76,000 for PRMD to conduct a "data scrape" that will search internet hosting sites to identify non-compliant TOT operators (services to be provided through a contracted entity).
- \$61,000 for an existing shared staff at PRMD who also provides ACTTC assistance, which creates a "one-stop shop" for vacation rentals and TOT collections.

The need for the two additional ACTTC positions is twofold. First, the number of registered operators in Sonoma County has tripled since 2013 and revenues have increased by over 50%. Staffing has not kept pace with this growth. Second, ACTTC's ability to collect all of the unrealized TOT revenue estimated at between \$760,000 and \$2.1 million significantly improves with the addition of staff to increase outreach and enforcement efforts.

- **Event Facilities Improvements** will receive 9% to enhance recreational activities that benefit local tourism and the tourist industry, including, but not limited to Veterans Halls (under contract or managed by the General Services Department). For Fiscal Year 2017-18, this equates to an allocation of \$460,000. General Services will bring back a Board item in the near term with a plan for utilization of these funds.
- **Tourism Impact Fund** will receive 10% to meet unique and urgent needs of areas within unincorporated Sonoma County that are most impacted by tourism. For Fiscal Year 2017-18, this equates to an allocation of \$500,000. While this recommendation was approved during the Board's study session in June, the Ad Hoc has developed further detail on the distribution of these funds. Specifically, the Ad Hoc recommends that the Board of Supervisors will consider these needs on a semi-annual basis. Funds will be allocated to each Supervisorial District proportionate to the amount of TOT collected by the District in the previous fiscal year. Historical

information of TOT revenue by Supervisorial District is included (Attachment H). Any unused funds in a single fiscal year will be accounted for and available in following years (i.e. unused funds will “roll over”).

Funds in this category may be used for such areas as safety improvements (e.g. lighted and/or marked crosswalks, traffic calming devices), environmental impact mitigation (e.g. removing trash from beaches, waterways, and areas with high tourist traffic), public safety (e.g. Fire Services), and other tourism mitigation activities, such as parking enforcement in heavily trafficked areas. Requests for funding will be processed through the County Administrator’s Office on a semi-annual basis. Staff will present recommendations for funding to the Board of Supervisors for approval.

Business Improvement Assessment Area Contract

On November 2, 2004, the Sonoma County Board of Supervisors adopted the ordinance creating the Sonoma County Tourism Business Improvement Area (Business Improvement Area) in various cities and in the unincorporated areas of the county. Under the ordinance, lodging establishments generating annual room revenue of \$350,000 or more must pay an assessment equal to 2% of such revenue. These funds are in addition to the Transient Occupancy Tax. Pursuant to Streets and Highways Code section 36535(d), the levy of the assessment and program to promote tourism has continued without change in the Business Improvement Area since 2004.

The contract between the County and the Sonoma County Tourism Bureau (Tourism Bureau) has previously been a combined contract to distribute TOT funds as well as Business Improvement Area (BIA) funds. As a best practice the two funding streams have now been separated into different contracts. The BIA contract is a continuation of a long standing contract with the Tourism Bureau to promote tourism in Sonoma County and was previously extended through October 31, 2017. The contract requires the Tourism Bureau to comply with all laws, obtain an independent audit of the use of the funds, and comply with an updated travel and meal reimbursement policy. The TOT contract is discussed earlier in this report.

The Measure L Ad Hoc is not making recommendations to change the Business Improvement Assessment (BIA) contract or program and staff recommends the Board authorize the attached contract, dated July 11, 2017, with the Tourism Bureau (Attachment I). The Tourism Bureau has spent a considerable amount of time updating its reimbursement policies and continues to work with industry experts to finalize its policy, which is also attached for the Board’s information (Attachment J).

The Sonoma County Treasurer-Tax Collector collects the Business Improvement Area Assessment from all qualifying entities in the unincorporated areas of the County and also remittances from member cities, which include the Cities of Santa Rosa, Rohnert Park, Petaluma, Cloverdale, Cotati, and Sebastopol, and the Town of Windsor. The City of Sonoma and the City of Healdsburg have not approved consent resolutions to join the Business Improvement Area. For Fiscal Year 2017-2018 (July 1, 2017 through June 30, 2018), BIA assessment revenue for all participating entities is projected to be \$5,027,854.

Prior Board Actions:	
<p>6/13/17 – The Board received a report on Transient Occupancy Tax recommendations and provided input to the Measure L Ad Hoc Committee for policy development.</p> <p>5/16/17 – The Board adopted a resolution continuing without change the levy of the Tourism Assessment on lodging businesses located within the Sonoma County Business Improvement Area and accepted the FY17-18 Annual Assessment Report.</p> <p>5/2/17- The Board adopted a resolution declaring its intention of continuing without change the levy of the Tourism Assessment on the lodging businesses located within the Sonoma County Business Improvement Area and accepted the its FY17-18 Annual Assessment Report.</p> <p>4/11/17: Board accepted the Measure L Ad Hoc Committee Charter to develop recommended policies to guide allocation of revenue from the recently adopted Transient Occupancy Tax increase, Measure L.</p> <p>12/15/16 – 2016 Sonoma County Tourism Annual Report and Resolution Continuing the Program and Assessments as Levied Without Change for the Sonoma County Tourism Business Improvement Area Through June 30, 2017.</p> <p>5/3/16: Board adopted updated Advertising and Promotions Policy and approved FY 2016-17 Advertising Program grant awards and funding allocation.</p>	
Strategic Plan Alignment	Goal 2: Economic and Environmental Stewardship
<p>Through grants provided to local non-profits to promote the County and encourage tourism, the Community Investment Program encourages economic development and job growth. Funding efforts to mitigate the impacts of tourism is of benefit to the safety and enhancement of the local community.</p>	

Fiscal Summary			
Expenditures	FY 17-18 Adopted	FY 18-19 Projected	FY 19-20 Projected
Budgeted Expenses			
Additional Appropriation Requested			
Total Expenditures			
Funding Sources			
General Fund			
State/Federal			
Fees/Other			
Use of Fund Balance			
Contingencies			
Total Sources			
Narrative Explanation of Fiscal Impacts:			
<p>All "Advertising Funds", now Community Investment Program funds, for FY 17-18 were previously approved by the Board as part of the annual budget process. 2.0 FTE (\$218,000 total) will be added to the Auditor-Controller/Treasurer-Tax Collector's budget with the Board's approval. In addition, the approval of the Tourism Board's TOT and BIA funding agreements total \$8,145,430 in FY 17-18 and \$7,027,845.</p> <p>A 20 year review of TOT revenue is provided in Attachment M.</p>			
Staffing Impacts			
Position Title (Payroll Classification)	Monthly Salary Range (A – I Step)	Additions (Number)	Deletions (Number)
Narrative Explanation of Staffing Impacts (If Required):			
Attachments:			
<p>Attachment A: Measure L Ad Hoc Committee Charter Attachment B: Previously adopted Advertising and Promotions Policy Attachment C: Proposed Community Investment Program Policy Attachment D: Crosswalk of funding categories from old policy to new policy Attachment E: Comparable Counties Transient Occupancy Tax (TOT) Contribution to General Fund</p>			

Attachment F: Draft Sonoma County Tourism Bureau Transient Occupancy Tax (TOT) Agreement
Attachment G: Sonoma County Tourism Funding Allocation from 2008-2016
Attachment H: Comparable Counties Tourism Bureau Funding and Staffing Levels
Attachment I: Budget and Position Resolution
Attachment J: TOT Revenue History by District
Attachment K: Sonoma County Tourism Bureau Business Improvement Area (BIA) Agreement
Attachment L: Sonoma County Tourism Bureau Travel and Expense Policy
Attachment M: TOT Revenue History

Related Items “On File” with the Clerk of the Board:

Adopted 07/08/86

Revised 10/02/01; 10/08/02; 09/12/03; 02/03/04; 04/18/06; 04/17/07; 05/10/11; 03/27/12, 6/10/13, 9/16/14, 2/10/15, 5/3/16, 6/13/16, 10/3/17, 6/5/18

COMMUNITY INVESTMENT FUND POLICY

I. SOURCE OF FUNDS

The Transient Occupancy Tax (Hotel/Motel Tax or Bed Tax) is authorized under State Revenue and Taxation Code Section 7280 as an additional source of non-property tax revenue to local government. This tax is levied in Sonoma County at a rate of 12%. The code does not require any specific use of the Transient Occupancy Tax (TOT). Funds developed as a result of the TOT may be utilized for General Fund, Community Investment Fund, or other purposes. Activities performed utilizing Community Investment Fund grants provided to non-profits must also be consistent with Government Code Section 26227.

II. POLICY STATEMENT

The Board of Supervisors wishes to invest in the community by supporting economic and workforce development, community non-profit grants, community services and safety, and program integrity and administration. The Board of Supervisors also wishes to encourage tourism in the County by supporting a series of promotional, community, and cultural activities through the use of Community Investment funds for: regional and national advertising, support of the community's spirit and its art/cultural programs, and promotion of other special events as deemed, by the Board, consistent with this Policy.

Funding levels will be established annually based on collections. In 2016, voters approved Measure L which authorized a 3% increase to the tax, bringing the total TOT rate to 12%. Measure L funds shall be tracked separately as described below. The Board of Supervisors has established a policy that 33% of the first 9% of TOT funds are designated to the General Fund, and the remaining funds will be used for community investments within this policy.

Entities who receive funding through the Community Investment Fund will be required to include the County of Sonoma logo and/or statement indicating sponsorship and/or support on all printed and online promotional materials, unless otherwise requested or agreed upon with the County.

III. ACTIVITIES ELIGIBLE FOR COMMUNITY INVESTMENT FUND GRANT AWARDS

A. Economic and Workforce Development

The Board desires to designate available funds towards projects and initiatives that stimulate and expand the county's economic vitality.

1. Chambers of Commerce:

Funding may be provided to Chambers of Commerce serving unincorporated areas of Sonoma County or who provide countywide services. Chambers located in the unincorporated area of the county and those serving the entire county will be given priority and fully funded prior to funding consideration of municipal Chambers of Commerce. Allocation of funds will be based upon an up to 10% match of membership dues and private cash contributions that are discretionary revenue to the chamber and are not associated with a particular event, function or position. A maximum of \$40,000 per year may be made available for Chambers of Commerce. Requests for funding can be made annually to the Economic Development Board.

2. Visitors Centers:

Funding for Visitor Centers within the county may be considered at the discretion of the Board of Supervisors. For purposes of funding, Visitors Centers will be distinct from the Tourism Marketing Program. Requests for funding can be made annually to the Economic Development Board.

3. Economic Development Board:

The Board of Supervisors has designated the Economic Development Board (EDB) to provide business assistance services to enable local businesses to maintain or expand their operations. The EDB will request funds annually through the budget process and will be considered at the discretion of the Board of Supervisors.

4. Tourism Marketing Program:

As determined by the Board of Supervisors, the County will provide TOT funds for advertising and promotional efforts as provided by the Sonoma County Tourism Bureau (SCTB). Commencing with Fiscal Year 2018-19, the County's TOT contribution to SCTB shall be a sum equivalent of the first 1.25% of the 9% of TOT collected in the unincorporated Sonoma County. The county's TOT contribution is disbursed through the EDB budget.

5. Visitor Way Finding and Signage:

Funding may be provided for permanent signage related to visitor way finding and area identification. These funds are intended for the installment and maintenance of permanent identification signs, not temporary or event promotion signs. Visitor Way Finding and Signage projects located in the unincorporated area of the county will be prioritized. A maximum of \$100,000 per year may be made under this category. Requests for funding can be made annually to the Economic Development Board.

6. Workforce Development and Scholarships:

Acknowledging that a qualified workforce is essential to the growing needs of the tourism industry as well as the overall health of the community, the Board of Supervisors has designated funds to support workforce development and to increase access to educational opportunities through scholarships. Workforce Development and Scholarships projects serving the entire county will be given priority. A maximum of \$500,000 per year may be made under this category. Requests may be made annually for multi-year grants.

B. Community Services and Safety

The Board is committed to using a portion of TOT funds to improve community services as well as to mitigate the impacts of tourism in communities.

1. Parks, Recreation, and Event Facilities:

The Board of Supervisors desires to provide TOT funds to County departments for recreational activities that benefit local tourism activities and the tourist industry, including, but not limited to, the Regional Parks Department and the Fairgrounds and Exposition, Inc., and Veterans Halls (under contract or managed by the General Services Department). Funding provided to the Regional Parks Department is allocated for operations and maintenance of existing park facilities only. Requests for TOT funds from County departments will be reviewed annually on a case-by-case basis and will be considered at the discretion of the Board of Supervisors.

2. Fire Services:

The Board of Supervisors is committed to addressing potential impacts on visitors' and residents' safety as a result of high-impact tourism within the unincorporated areas of the county. See Section E(3) below which dedicates a total of 20% of Measure L revenue to be distributed to Fire Services within the unincorporated area annually.

3. Affordable Housing and Homeless Services:

The Board of Supervisors recognizes that vacation rentals and other impacts from tourism result in an increased need in affordable housing. See Section E(4) below which dedicates a total of 13% of Measure L revenue to be distributed for affordable and workforce housing partnerships within the unincorporated area for housing and rent stabilization as well as for homeless services. Funds shall be allocated to the existing County Fund for Housing (CFH) as well as to homeless services needs, administered by the Community Development Commission.

4. Roads Funding:

To mitigate the impact of increased vehicles on roads in the unincorporated area of Sonoma County, the Board of Supervisors commits a total of 20% of Measure L revenue to Transportation and Public Works (TPW) for improvements to local roads. Funding will support projects included in the annual TPW Roads Plan. See Section E(1) below.

5. Tourism Impact Fund:

This fund has been established to meet unique and urgent needs of areas within unincorporated Sonoma County who are most impacted by tourism. A total of 10% of Measure L revenue will be distributed to mitigate the impacts of tourism in communities. The Board of Supervisors will consider these needs on an ongoing basis throughout the year. Unused funds in a single fiscal year will be accounted for and available in following years. See examples of use in Section E(7) below.

C. Community Non-Profit Grants

The Board of Supervisors wishes to invest in the community by supporting non-profit grants to promote arts and cultural activities, agricultural industry, historical preservation activities, promotional activities which enhance tourism and industry, and/or local community events which encourage a sense of community.

Community Investment Fund grant awards will be based upon an evaluation of all application materials, with a focus on the return on investment and benefit to be gained, including potential tourism and business revenue, from providing financial support to the event/organization. Events and organizations who demonstrate ability to receive and/or contribute match funding or grants as the result of receipt of Community Investment Funds will be given priority consideration in the application review process and in consideration of amount of grant award. County funds are not to be used for individual business promotion or advertisement.

The following grant opportunities are available:

1. **Agricultural Promotion**

The Board of Supervisors desires to support advertising campaigns and promotional activities directed by Sonoma County agricultural industries. Funds will be used to support advertising and promotional efforts of diverse organizations within the agricultural sector.

Requests for funding can be made annually by non-profits entities and a maximum of \$185,000 per year may be made available under this category.

2. **Historical Commissions**

The Board of Supervisors desires to support historical preservation of the county's culture and historical records and architecture. A maximum of \$60,000 per year may be made available for this category.

The County has designated the Sonoma County Landmarks Commission to advise on the distribution of funds for preservation and restoration of historically significant buildings. Funding may be provided to this Commission to accept grant applications for the renovation, restoration and/or preservation of historical facilities.

The Board has designated a Historical Records Commission to review and make recommendations regarding the maintenance and destruction and retention of records, which may be of historical significance. Funding under this category may be provided for these activities.

3. **Local Events, Organizations, and Economic Development Grants**

The Board has established this category to assist small cultural, artistic, and countywide events and organizations as well as events occurring during the off peak tourism season (November 15 through April 15) with funding for advertising and economic development efforts that promote Sonoma County and encourage visitors to frequent the county throughout the entire year. Funds can also be allocated for activities that

support community organizations and will be made at the discretion of each Supervisorial District. Events and organizations will make requests annually to the Supervisorial District in which their event/organization exists.

\$250,000 has been allocated for this category and will be divided equally among supervisorial districts to be used at the discretion of each district.

4. Major County Events and Organizations

The Board of Supervisors desires to promote major events and cultural and artistic organizations which draw countywide, regional, state and national interest as evidenced by widespread media promotion and which can demonstrate a significant population of participants and visitors from outside the county. A maximum of \$300,000 per year may be made available for advertising and promotion of major events and organizations within this category.

The following general guidelines apply to this category:

- a. Must demonstrate overall attendance either at a single event or through a series of events in excess of 15,000, with significant (20% or more) demonstrated attendance from out of the county.
- a. Must demonstrate extent of out-of-county attendance and demonstrate link to overnight stays from attendees.
- b. Must demonstrate advertising expenses exceeding \$25,000, of which the Advertising funds being requested must not exceed 50% of total advertising expenses for the event or organization.
- c. Must demonstrate a major advertising campaign plan focused outside of the county.
- d. Must demonstrate the extent to which the event, season series, exhibit, or marketing effort will support the county's economic development in the form of local job promotion, local education contribution, and/or local business-chambers of commerce-visitors centers partnerships.
- e. In addition to advertising and promotional efforts, funds may also be used to support Sonoma County based documentary films that document and promote or maintain a historical record of the region, culture, community and arts. The following general guidelines will apply:
 - Must demonstrate historical, current social issues, cultural, regional or specific human experiences in Sonoma County that raise awareness and create an impact upon the viewing audience.
 - Must have real, factual situations and circumstances which leave audiences better informed.
 - Must provide detail of advertising/promotional campaign activities, including the type of advertising and region(s) of promotion.

- Must be able to demonstrate that the film will be exhibited publicly, including but not limited to broadcast and cable television, and Internet transmission.
- Applicant must provide a production timeline including release date of film and the cost of the activity in relation to the amount of grant funds requested.

The maximum advertising fund contribution which can be applied for is \$50,000. Funds are only to be used for advertising and promotion of the events and not towards the cost of event production.

The following will be requested as part of the application process for all events and organizations who apply for advertising funds under this category. This information is not required and failure to provide will not result in disqualification, however, the information will be used to determine grant awards and amounts based on demonstrated ability to most effectively promote tourism, agricultural, and/or economic development.

- a. A complete Community Investment Fund grant application (form provided by the County);
- b. A completed post-program/event report containing results and benefits of prior year activities and events, if the entity received Community Investment Funds in the previous fiscal year (form provided by the County);
- c. Detail the advertising/promotional campaign for which advertising funds are being requested, including the type of advertising and region(s) of promotion;
- d. Detail how these activities will promote attendance, including expected attendance, overnight stays, and visitor spending; and
- e. Detail how the County of Sonoma organization will be promoted as an organization/event sponsor in advertising materials, available event/booth attendance, and other such activities. Information should also be provided on available sponsorship packages.
- f. Must include details of other funding support from local organizations or local government entities.

5. Seasonal and Off Peak Programs

The Board of Supervisors desires to promote seasonal programs, events, and cultural and artistic organizations as well as events that occur during the off peak tourism season (November 15 through April 15) which draw countywide and regional interest and which can demonstrate participants and visitors from within and/or outside the county. The program will pay for the direct cost of advertising. A maximum of \$50,000 per year may be made available under this category.

The maximum advertising fund contribution which can be applied for is \$5,000. The following general guidelines apply to this category:

- a. Must detail overall attendance from in and/or outside of the county.
- b. Must demonstrate local and/or out of county advertising campaign plan.
- c. Must demonstrate the extent to which the event, seasonal program, exhibit, or marketing effort will support the County's economic development in the form of local job promotion, local education contribution, and/or overnight stays from attendees.
- d. Must provide a budget of total advertising expenses in relation to the amount of grant funds being applied for.
- e. Must include details of other funding support from local organizations or local government entities.

D. Program Integrity and Administration

The Board of Supervisors desires to provide Community Investment funds for certain county departmental activities that benefit local tourism activities and the tourist industry, and which preserve and promote Sonoma County history. Community Investment funds may be used for salaries of County employees when participating in activities funded by Community Investment funds. Administrative costs (including collection, audit, program coordination, consultant, and legal services) should not exceed 10% of the estimated and/or budgeted TOT revenues.

Request for Community Investment funds from departments will be reviewed annually on a case-by-case basis.

1. Collections/Audit Services:

Revenue and tax collection services and program and grantee audit services are provided for this Program. Funding shall be recommended by the County Administrator's Office annually to fund these activities.

2. Legal Services:

Legal guidance, advice, interpretation and other related services are provided for this Program. Funding shall be recommended by the County Administrator's Office annually to fund these activities.

3. Program Administration Services:

Administration of this Program, including policy management and review, budget management and review, application review and recommendation, contract management, claims processing, and other related activities are provided by the County Administrator's Office. Funding shall be recommended by the County Administrator's Office annually to fund these activities.

E. Measure L Revenue

The Board of Supervisors will track and distribute the 3% “Measure L increase” to TOT separately. The categories established for Measure L funding distribution are based on the educational information provided to voters as part of the Measure L campaign.

Amendments to these funding commitments will be considered at the discretion of the Board of Supervisors.

1. Roads Repair and Improvement, 20%

To mitigate the impact of increased vehicles on roads in the unincorporated area of Sonoma County, the Board of Supervisors commits a total of 20% of Measure L revenue to Transportation and Public Works (TPW) for improvements to local roads. Funding will support projects included in the annual TPW Roads Plan.

2. Regional Parks, 20%

A total of 20% of Measure L funds will be used to fund Regional Parks, effective for Fiscal Year 2017-18 and Fiscal Year 2018-19. Funding in this area for the Regional Parks Department will be prioritized to increase public access and support the development of new park facilities.

3. Fire Services, 20%

It is in the interest of the county to provide for the safety and emergency care of residents and visitors. The tourism industry, while beneficial for the health and economy of the county, can strain the agencies responsible for emergency response. To help alleviate this strain and to encourage greater regional consolidation within the county’s fire system, funds will be directed at the discretion of the Board of Supervisors to the Fire and Emergency Services Department for distribution. The Department will make recommendations for investment in the county fire and emergency response system based on input from the Fire Services Advisory Council and county-wide needs. The Board of Supervisors will prioritize recommendations that further regional consolidation, provide equipment and personnel support in high risk areas, and provide increased response coverage in underserved/high risk areas of the county.

4. Affordable Housing, 13%

The Board of Supervisors recognizes that vacation rentals and other impacts from tourism result in an increased need in affordable housing. A total of 13% of Measure L revenue will be distributed for affordable and workforce housing partnerships, for housing and rent stabilization, and for homeless services. Funds shall be allocated to the existing County Fund for Housing (CFH) as well as to homeless services needs, administrated by the Community Development Commission.

5. Code Enforcement and Operator Compliance, 8%

A total of 8% of Measure L funds will be used to enhance administration of this Program, including revenue and tax collection services and program and grantee audit services as well as code enforcement and operator compliance related activities. Funding shall be recommended by the County Administrator’s Office within the annual budget process to fund these activities.

6. Event Facilities Improvements, such as Veteran’s Halls, 9%

The Board of Supervisors desires to provide 9% of Measure L funds to County owned facilities that enhance recreational activities that benefit local tourism and the tourist industry, including, but not limited to Veterans Halls (under contract or managed by the General Services Department).

7. Tourism Impact Fund, 10%

This fund has been established to meet unique and urgent needs of areas within unincorporated Sonoma County that are most impacted by tourism. A total of 10% of Measure L revenue will be distributed to mitigate the impacts of tourism in communities. The Board of Supervisors will consider these needs on semi-annual basis. Funds will be allocated to each Supervisorial District proportionate to the amount of TOT collected by the District in the previous fiscal year. Unused funds in a single fiscal year will be accounted for and available in following years.

Funds in this category may be used for activities such as safety improvements (e.g. lighted and/or marked crosswalks, traffic calming devices), environmental impact mitigation (e.g. removing trash from beaches, waterways, and areas with high tourist traffic), public safety (e.g. Fire Services), and other tourism mitigation activities, such as parking enforcement in heavily trafficked areas. Requests for funding will be processed through the County Administrator’s Office on a semi-annual basis. Staff will present recommendations for funding to the Board of Supervisors for approval.

Sonoma County Tourism - Local Tourism Enhancement Grants

Project	Amount Funded by Supervisor Grant	Recommended Funding	District 1	District 2	District 3	District 4	District 5	Other
Jack London Park Partners - Various Operations	\$1,000.00	\$10,000.00	\$10,000					
Sonoma Ecology Center		\$30,000.00	\$15,000		\$15,000			
Wildfire Mental Health Collaborative (all)		\$40,000.00	\$8,000	\$8,000	\$8,000	\$8,000	\$8,000	
Sonoma Land Trust - Signage at Sears Point, Water Sustainability Projects		\$25,000.00	\$5,000	\$10,000	\$10,000			
Petaluma Visitors Center - Way-finding		\$10,000.00		\$10,000				
Friends of the Petaluma River - Sustainability Projects		\$25,000.00		\$25,000				
Cinco de Mayo Santa Rosa, Inc, - Scholarship program		\$10,000.00	\$2,000	\$2,000	\$2,000	\$2,000	\$2,000	
Russian River Keepers - Clean River Alliance		\$25,000.00				\$10,000	\$15,000	
Geyserville Chamber of Commerce - Scholarship program for Geyserville New Tech graduates		\$5,000.00				\$5,000		
Friends of Lake Sonoma		\$25,000.00				\$25,000		
Russian River Chamber of Commerce - Russian River Sustainability Programming		\$20,000.00					\$20,000	
Forestville Chamber of Commerce - New signage		\$10,000.00					\$10,000	
Coastwalk/California Coastal Trail Association		\$10,000.00					\$10,000	
Redwood Coast Chamber and Visitors Center (way-finding)		\$5,000.00						\$5,000
TOTAL		\$250,000.00						
District 1			\$40,000					
District 2				\$55,000				
District 3					\$35,000			
District 4						\$50,000		
District 5							\$65,000	
Other								\$5,000



County of Sonoma
Permit & Resource Management Department

Sonoma County Planning Commission

ACTIONS

Permit Sonoma
2550 Ventura Avenue, Santa Rosa, CA 95403
(707) 565-1900 FAX (707) 565-1103

Date: November 1, 2018
Meeting No.: 18-13

ROLL CALL

Dick Fogg
Larry Reed
Komron Shahhosseini
Ariel Kelley
Pamela Davis, Chair

STAFF MEMBERS

Jennifer Barrett
Georgia McDaniel
Arielle Kohn, Secretary
Leslie A. Thomsen, Deputy County Counsel

Minutes Approved – Combined PC/BZA - November 9, 2017
Minutes Continued - Planning Commission - August 30, 2018

Correspondence

Board of Zoning Adjustments/Board of Supervisors Actions
Commissioner Announcements/Disclosures
Public Appearances

PLANNING COMMISSION UNCONTESTED CALENDAR

PC Item No.: 1
Time: 1:05 pm
File: MNS12-0004
Applicant: Kim Gardner
Owners: Kim Gardner
Cont. from: N/A
Staff: Georgia McDaniel
Env. Doc: Mitigated Negative Declaration

Proposal: Request for a Minor Subdivision of 6.06 acres resulting in two parcels of 1.53 ± acres in size each and a designated remainder of 3.0 ± acres with a reduction of the design and improvement standards pursuant to Section 25-43 of the Sonoma County Municipal Code to increase the length to width ratio limitation required per Section 25-42(b) of the Sonoma County Subdivision Ordinance.

Location: 245 Paula Lane, Petaluma

APN: 019-080-003

District: 2

Zoning: AR (Agricultural and Residential) 2-acre density and no combining zones

Sonoma County Planning Commission Actions

Date: November 1, 2018

Page 2

Action: **Commissioner Reed** motioned to adopt the mitigated negative declaration and approve the request with modified conditions. Seconded by **Commissioner Shahhosseini** and passed with a 3-1-1 vote

Appeal Deadline: ten days

Resolution No.: 18-019

Vote:

Commissioner Fogg	Aye
Commissioner Reed	Aye
Commissioner Shahhosseini	Aye
Commissioner Kelley	Absent
Commissioner Davis	No

Ayes: 3

Noes: 1

Absent: 1

Abstain:



County of Sonoma
Permit & Resource Management Department

Sonoma County Planning Commission

REVISED ACTIONS

Permit Sonoma
2550 Ventura Avenue, Santa Rosa, CA 95403
(707) 565-1900 FAX (707) 565-1103

Date: October 4, 2018
Meeting No.: 18-12

ROLL CALL

Greg Carr
Larry Reed
Komron Shahhosseini
Ariel Kelley
Pamela Davis, Chair

STAFF MEMBERS

Jennifer Barrett
Hannah Spencer
Arielle Kohn, Secretary
Leslie A. Thomsen, Deputy County Counsel

1:00 PM Call to order and Pledge of Allegiance

Minutes Approved - August 2, 2018

Minutes Continued – Combined PC/BZA – November 9, 2017

Correspondence

Board of Zoning Adjustments/Board of Supervisors Actions

Commissioner Announcements/Disclosures

Public Appearances

PLANNING COMMISSION UNCONTESTED CALENDAR

PC Item No.: 1
Time: 1:05 pm
File: ZCE18-0011
Applicant: Tom Berry and County of Sonoma
Owners: Rachel Curran, Brian Wares and Robert Mann
Cont. from: N/A
Staff: Hannah Spencer
Env. Doc: Categorically Exempt, CEQA Guidelines Section 15061(b)(3)

Proposal: Amend the Official Zoning Database and Coastal Zoning Database to correct minor technical errors resulting from zoning map updates and prior approval of a noncontroversial lot line adjustment.

Location: 14500 Meyers Grade Rd and 5600 Highway 1 in Jenner
APNS: 109-170-034, -035 and 109-170-032, -033
District: 5
Zoning: TP (Timberland Production), B6 160 / TP (Timberland Production) CC (Coastal Zone) B6 160/640 (Ac/DU)/AcMIN, RC (Riparian Corridor) 50-foot and 100-foot setbacks, SR (Scenic Resources)

Sonoma County Planning Commission Revised Actions

Date: October 4, 2018

Page 2

Action: **Commissioner Davis** motioned to recommend approval of the technical corrections to the Board of Supervisors. The motion also included recommending approval of the two other resolutions. Seconded by **Commissioner Carr** and passed with a 5-0 vote.

Appeal Deadline: N/A

Resolution No.: 18-018

Resolution No.: 18-019 (Zone change at 15600 Highway 1, Jenner APN 109-170-032 and -033)

Resolution No.: 18-020 (Zone change at 14500 Meyers Grade Road, Jenner APN 109-170-035)

Vote:

Commissioner Carr - aye

Commissioner Reed - aye

Commissioner Shahhosseini - aye

Commissioner Kelley - aye

Commissioner Davis - aye

Ayes: 5

Noes: 0

Absent: 0

Abstain: 0